



Manufactured by:
Backyard Discovery
3305 Airport Drive, Pittsburg, KS 66762
800-856-4445

Backyard Discovery Australia Pty Ltd 2/7 Hood Street, Hampton VIC 3188, Phone: 1800-087-941

12x10 Barrington Gazebo

MODEL # : 2406094



Please visit www.backyarddiscovery.com
For the most up to date assembly manual, to register your product, or to order
replacement parts *Para obtener instrucciones en español, visite*
www.backyarddiscovery.com



EASY STEP-BY-STEP
3D INTERACTIVE INSTRUCTIONS
DOWNLOAD THE FREE APP



OWNER'S MANUAL - BASIC SETUP DIMENSIONS & ASSEMBLY NOTES

It is critically important that you start with square and level footings, concrete pad or deck to attach your structure

- Pay close attention to the items needed for each step. Make sure you are using the correct hardware for each step. Using incorrect hardware may result in improper assembly
- Remember to double check for underground utilities and overhead electrical lines

Post mounts are provided with your structure which allows you to permanently install your structure to a pre-existing or new wood or concrete surface. See Anchor Instructions for further details and recommendations.

- The hardware to attach the post mounts to the structure is included.
- The hardware to mount the structure permanently to a concrete surface is included.
- The hardware to mount the structure permanently to a wood deck is NOT included and will need to be purchased separately. You must ensure there is ample structural support under the deck before permanently attaching.

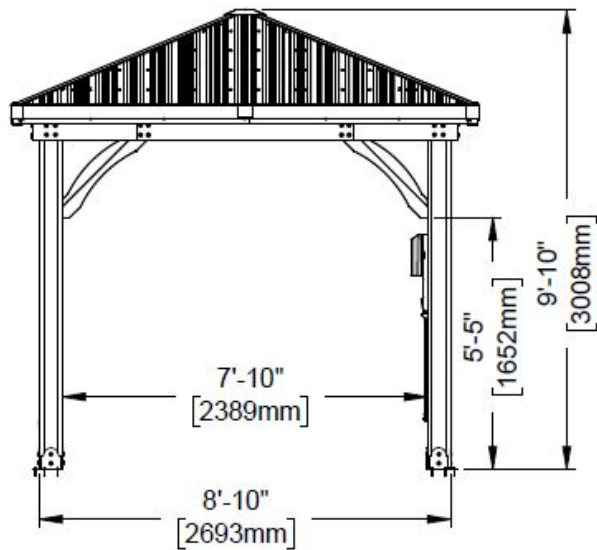
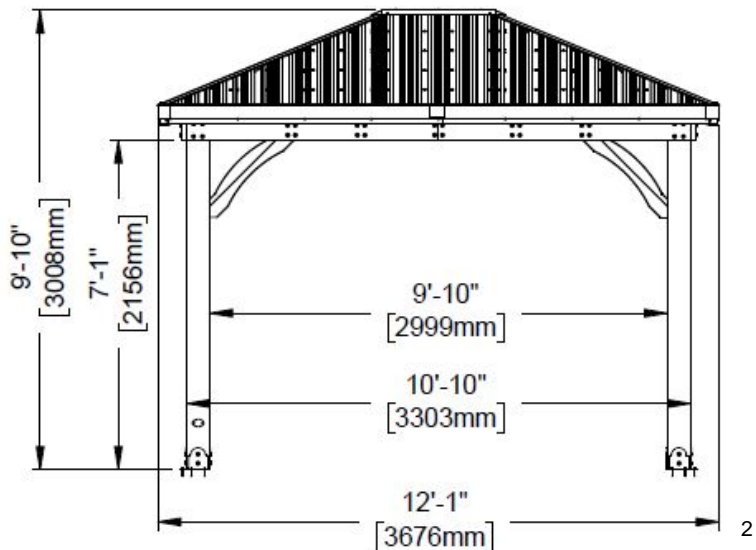
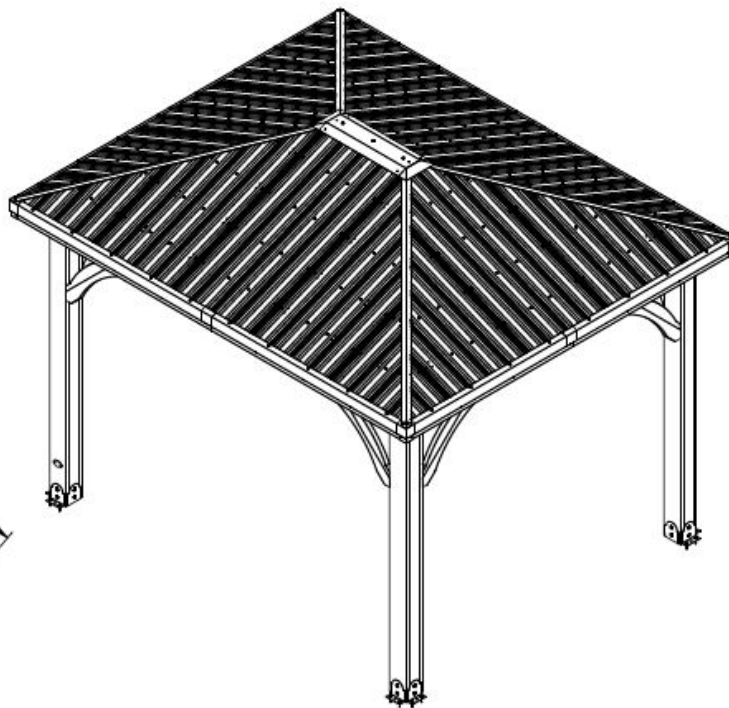
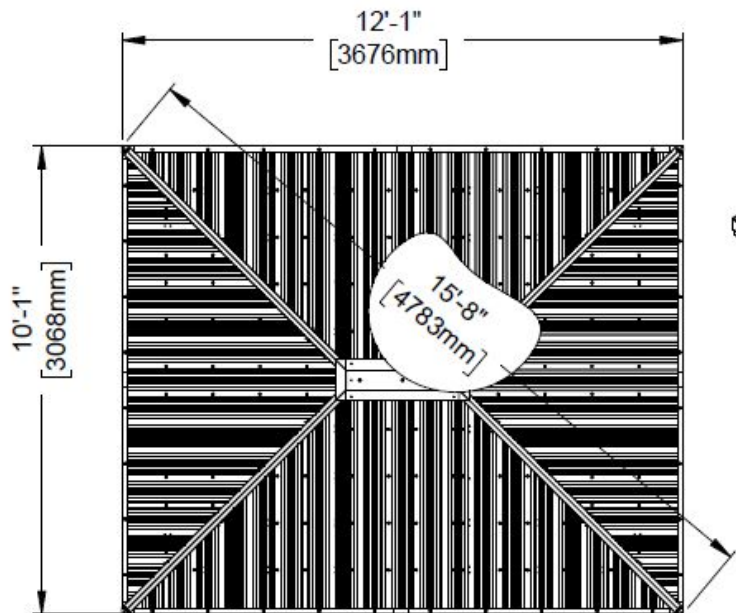

OWNER'S MANUAL - ANCHORING LAYOUT

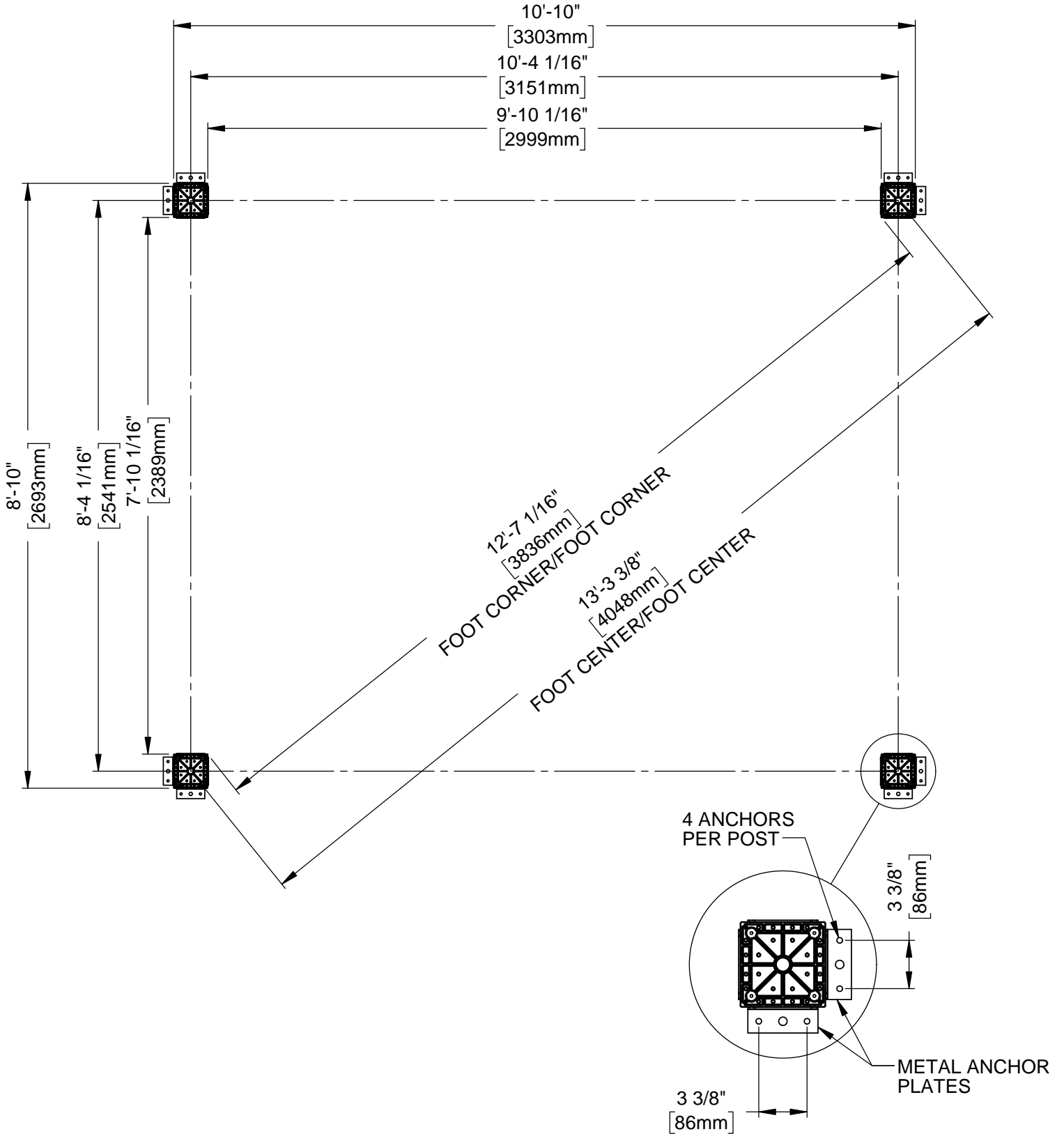

OWNER'S MANUAL - PARTS IDENTIFICATION

Wood Components (Not to Scale)



D01 BEAM - W4L16778
(x4) 1 7/16"x5 1/4"x30 15/16" (36x134x786)



D02 BEAM - W4L16779
(x2) 1 7/16"x5 1/4"x55 3/4" (36x134x1416)



E01 RAFTER - W4L16786
(x2) 1 7/16"x3 3/8"x20 13/16" (36x86x528)



E03 RAFTER - W4L16788
(x2) 1 7/16"x3 3/8"x58 1/8" (36x86x1477)



E02 RAFTER - W4L16787
(x2) 1 7/16"x3 3/8"x39 7/16" (36x86x1002)



E04 RAFTER - W4L16789
(x2) 1 7/16"x3 3/8"x63 11/16" (36x86x1617)

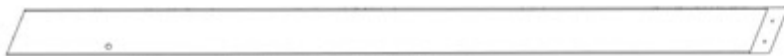

E05 RAFTER - W4L16790
(x2) 1 7/16"x3 3/8"x58 1/8" (36x86x1477)



E06 RAFTER - W4L16791
(x2) 1 7/16"x3 3/8"x39 7/16" (36x86x1002)

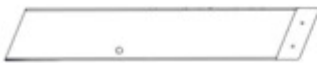

E07 RAFTER - W4L16792
(x2) 1 7/16"x3 3/8"x20 13/16" (36x86x528)



E08 RAFTER - W4L16804
(x2) 1 7/16"x3 3/8"x57 1/2" (36x86x1460)

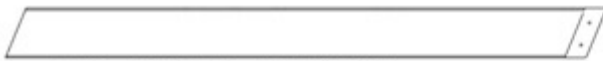

E09 RAFTER - W4L16805
(x2) 1 7/16"x3 3/8"x41 3/16" (36x86x1047)



E10 RAFTER - W4L16806
(x2) 1 7/16"x3 3/8"x20 3/4" (36x86x527)



E11 RAFTER - W4L16807
(x2) 1 7/16"x3 3/8"x41 3/16" (36x86x1047)



E12 RAFTER - W4L16808
(x2) 1 7/16"x3 3/8"x20 3/4" (36x86x527)



G01 BEAM - W4L16775
(x4) 15/16"x5 1/4"x46" (24x134x1144)

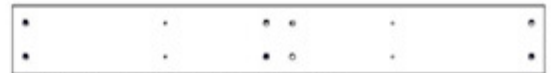

G02 BEAM - W4L16776
(x2) 15/16"x5 1/4"x39 15/16" (24x134x1014)



G03 BEAM - W4L16777
(x4) 15/16"x5 1/4"x65" (24x134x1651)



H01 ROOF SUPPORT - W4L16781
(x4) 15/16"x3 3/8"x75 3/16" (24x86x1909)



H02 ROOF JOIST - W4L16782
(x2) 15/16"x3 3/8"x25 9/16" (24x86x648)

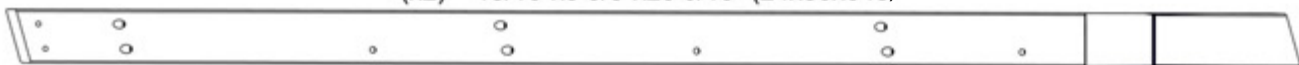

H03 ROOF JOIST - W4L16783
(x2) 15/16"x3 3/8"x86 3/4" (24x86x2203)

OWNER'S MANUAL - PARTS IDENTIFICATION

Wood Components (Not to Scale)



H04 ROOF JOIST - W4L16784
(x2) 15/16"x3 3/8"x85 3/4" (24x86x2203)



H05 PURLIN - W4L16793
(x2) 15/16"x3 3/8"x80 3/16" (24x86x2036)

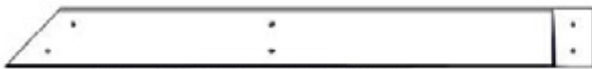

H06 PURLIN - W4L16794
(x2) 15/16"x3 3/8"x33 5/8" (24x86x854)



H07 PURLIN - W4L16795
(x2) 15/16"x3 3/8"x45 11/16" (24x86x1160)



H08 PURLIN - W4L16796
(x2) 15/16"x3 3/8"x68 1/8" (24x86x1730)



H09 PURLIN - W4L16797
(x2) 15/16"x3 3/8"x75 1/4" (24x86x1912)

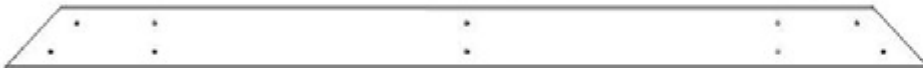

H10 PURLIN - W4L16798
(x2) 15/16"x3 3/8"x51 1/8" (24x86x1299)



H11 ROOF JOIST - W4L16801
(x2) 15/16"x3 3/8"x12 15/16" (24x86x328)



H12 ROOF JOIST - W4L16802
(x2) 15/16"x3 3/8"x79 1/4" (24x86x2013)



H13 PURLIN - W4L16803
(x2) 15/16"x3 3/8"x79 1/4" (24x86x2013)



H14 PURLIN - W4L16809
(x4) 15/16"x3 3/8"x50 13/16" (24x86x1290)

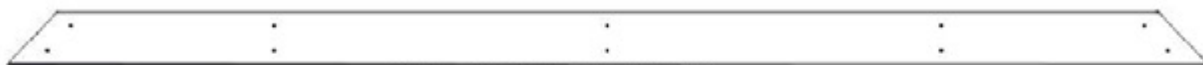

H15 PURLIN - W4L16810
(x2) 15/16"x3 3/8"x74 15/16" (24x86x1904)

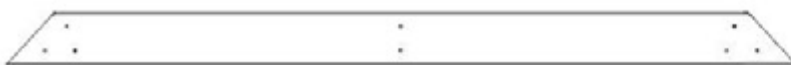

H16 PURLIN - W4L16811
(x2) 15/16"x3 3/8"x50 11/16" (24x86x1288)

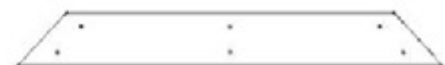

H17 PURLIN - W4L16812
(x2) 15/16"x3 3/8"x26 1/2" (24x86x673)



H29 ROOF SUPPORT - W4L15160
(x1) 15/16"x3 3/8"x24" (24x86x610)

OWNER'S MANUAL - PARTS IDENTIFICATION

Wood Components (Not to Scale)



Q01 ROOF JOIST - W4L16785
(x4) 15/16"x4 7/16"x72 1/4" (24x112x1835)



Q02 ROOF JOIST - W4L16800
(x4) 15/16"x4 7/16"x61 3/16" (24x112x1554)



T02 PURLIN - W4L16813
(x2) 15/16"x1 5/16"x15" (24x34x382)



T01 PURLIN - W4L16799
(x2) 15/16"x1 5/16"x27 7/8" (24x34x708)



C01 CORBEL - W2A03198
(x7) 1 7/16"x6 7/16"x36 1/4" (36x163x893)



C02 CORBEL W/TAG - W2A03199
(x1) 1 7/16"x6 7/16"x36 1/4" (36x163x893)



P01 POST - W2A03202
(x2) 6"x6"x89 1/2" (152x152x2274)



P02 POST - W2A03203
(x2) 6"x6"x89 1/2" (152x152x2274)

OWNER'S MANUAL - PARTS IDENTIFICATION

Hardware Components

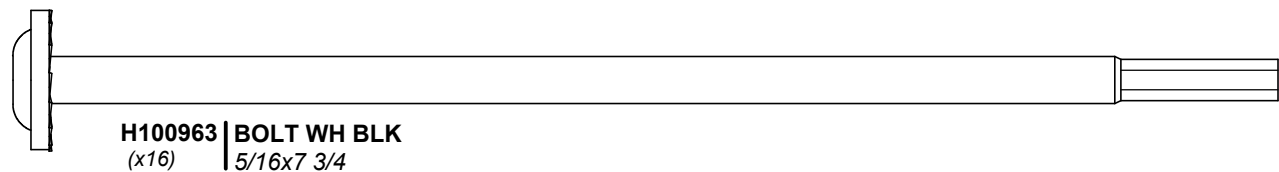
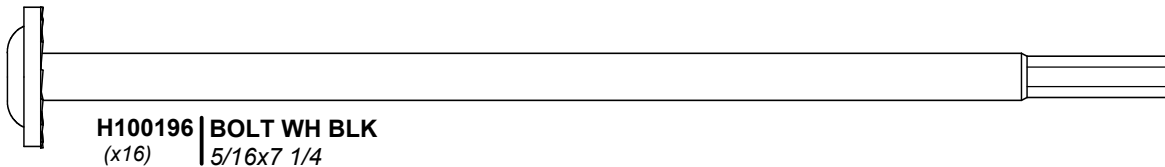
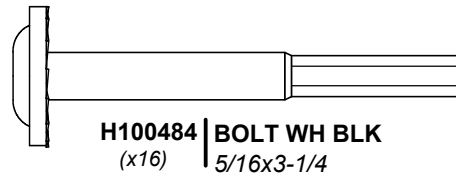
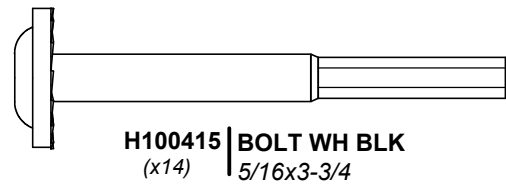
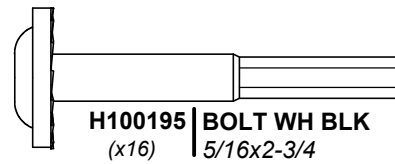
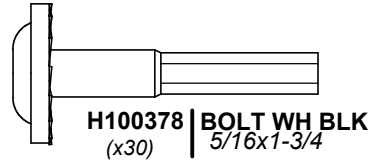
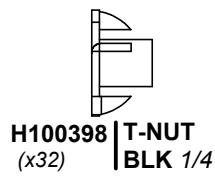
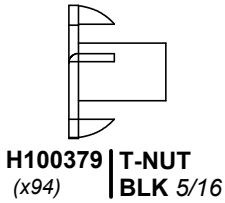
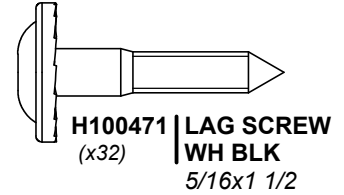
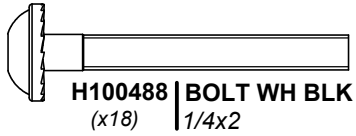
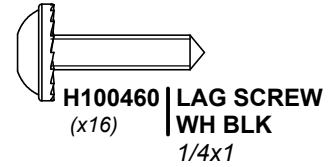
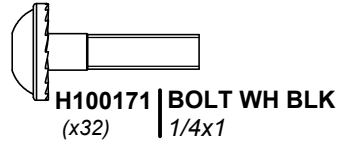

OWNER'S MANUAL - PARTS IDENTIFICATION

Hardware Components



H100385 | SCREW PFH
(x36) | BLK 8x1

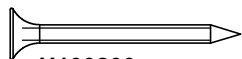

H100200 | SCREW PFH
(x16) | BLK 8x1 1/2

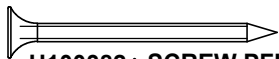

H100382 | SCREW PFH
(x44) | BLK 8x1 3/4

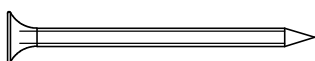

H100391 | SCREW PFH
(x188) | BLK 8x2

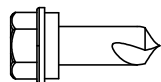

H100759 | SCREW
TAPPING
(x44) | 1/4x1

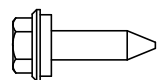

H100833 | SCREW
WOODGRIP
(x188) | 10x3/4

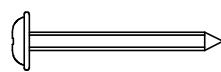

H100536 | SCREW PWH
(x40) | BLK 8x1 1/4

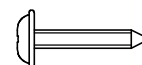

H100392 | SCREW PWH
(x16) | BLK 8x3/4

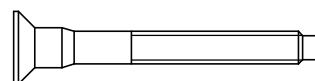

H101030 | SCREW CONFIRMAT BLK
(x96) | 7x2

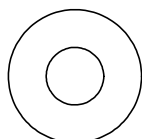

H100770 | WASHER FLAT
(x14) | BLK 5/16



H101034 | WEATHER PROOF
(x3) | WASHER



H100479 | NUT LOCK BLK
(x14) | 5/16

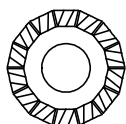

H100198 | WASHER LOCK
(x108) | EXT BLK

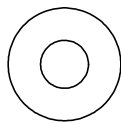

H100630 | WASHER FLAT
(x34) | BLK 8x19

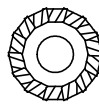

H100405 | WASHER
(x8) | LOCK EXT
BLK 6x15



H100653 | NUT LOCK BLK
(x18) | 1/4

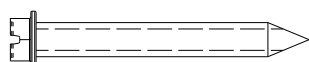

H100120 | SCREW CONCRETE
(x16) | ANCHOR 1/4x2

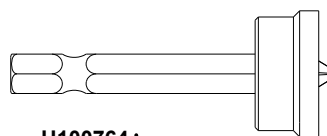

H100764 | SCREW SETTER
(x1)

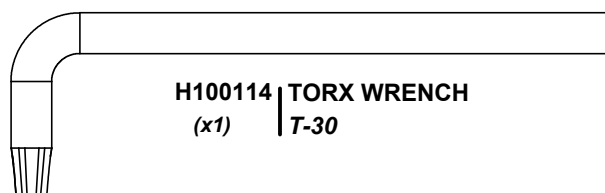

H100114 | TORX WRENCH
(x1) | T-30

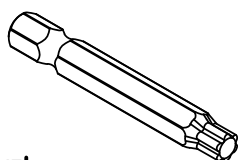

H100147 | T-30 TORX BIT
(x1)

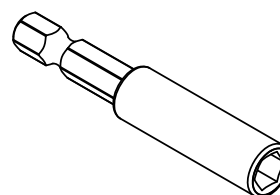

H101100 | BIT ADAPTOR
(x1)

OWNER'S MANUAL - PARTS IDENTIFICATION

Accessory Components (Not to Scale)

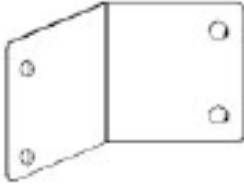

A4M01667 | PANEL BRACKET
(x2)

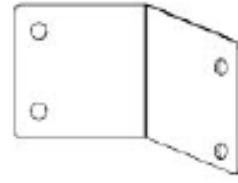

A4M01666 | PANEL BRACKET
(x2)

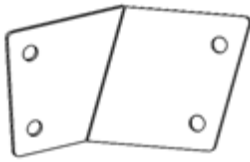

A4M01664 | PANEL BRACKET
(x2)

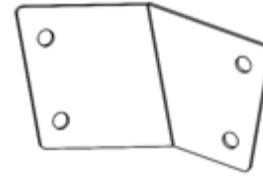

A4M01665 | PANEL BRACKET
(x2)



A4M01228 | RAFTER CLIP
(x18)

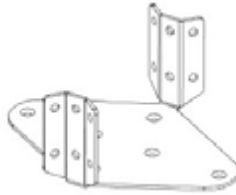

A4M02501 | FAN MOUNT BRACKET
(x2)

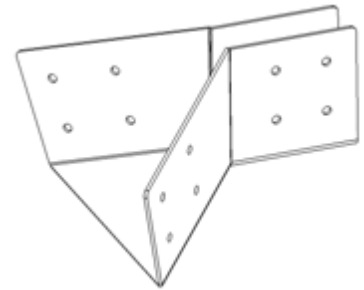

A4M01184 | PANEL SUPPORT BRACKET
(x2)

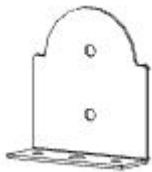

A4M01793 | STEEL POST PLATE
(x8)

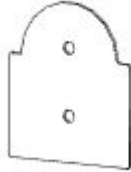

A4M01794 | STEEL POST ANCHOR PLATE
(x8)

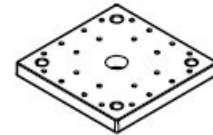

A6P00308 | 6x6 POST FOOT
(x4)



A4M02158 | BYD ID TAG
(x1) | (SMALL)
WITHOUT
AGES



A4M01185 | CORNER BRACKET
(x4)

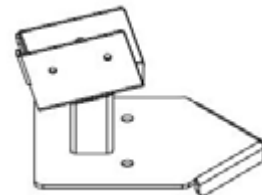

A4M01234 | POST CLIP
(x4)

OWNER'S MANUAL - PARTS IDENTIFICATION

Accessory Components (Not to Scale)



A4M02900 | EDGE TRIM SHORT
(x4)

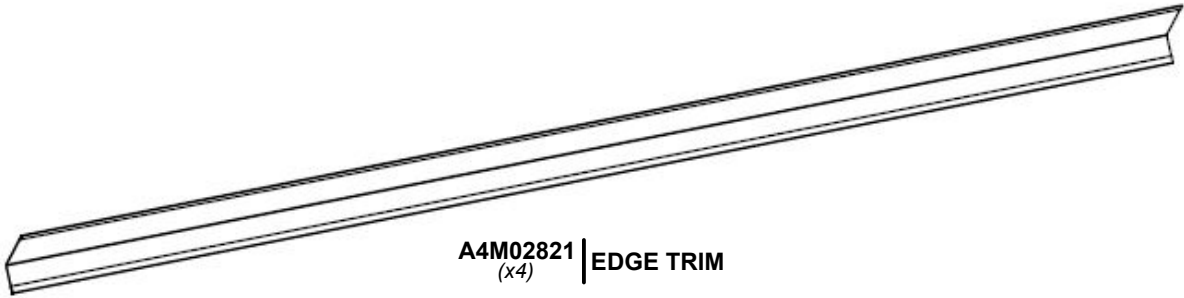

A4M02821 | EDGE TRIM
(x4)

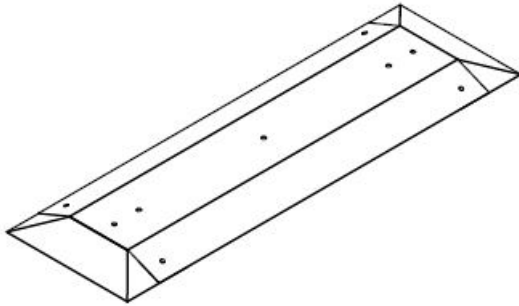

A4M02886 | RIDGE PEAK CAP
(x1)



A4M01205 | METAL SPACER
(x3)

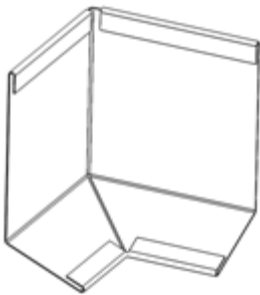

A4M02825 | EDGE TRIM CORNER SPLICE
(x4)

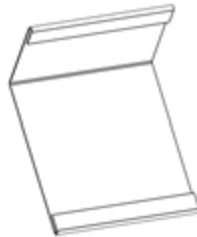

A4M02822 | EDGE TRIM SPLICE
(x4)

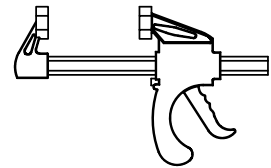

A6P00460 | 6" QUICK RELEASE
BAR CLAMP
(x2)

OWNER'S MANUAL - PARTS IDENTIFICATION

Accessory Components (Not to Scale)

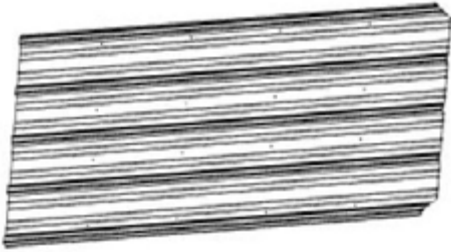

A4M02901-1 | 29 GA STEEL SHEETING
(x2)

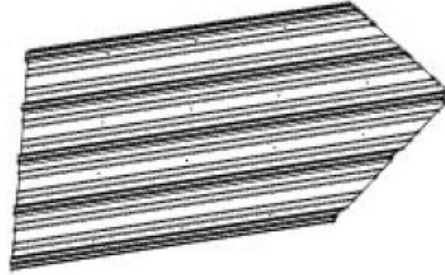

A4M02901-2 | 29 GA STEEL SHEETING
(x2)

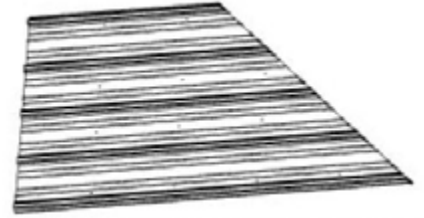

A4M02902-1 | 29 GA STEEL SHEETING
(x2)



A4M02902-2 | 29 GA STEEL SHEETING
(x2)



A4M02903-1 | 29 GA STEEL SHEETING
(x2)

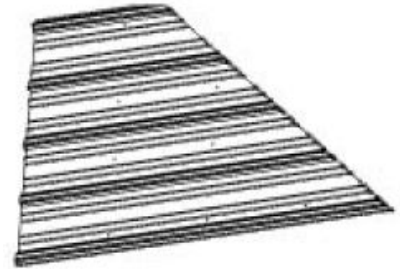

A4M02903-2 | 29 GA STEEL SHEETING
(x2)

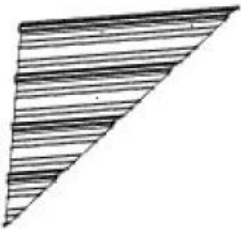

A4M02904-1 | 29 GA STEEL SHEETING
(x2)

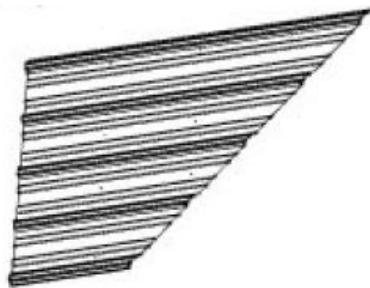

A4M02904-2 | 29 GA STEEL SHEETING
(x2)

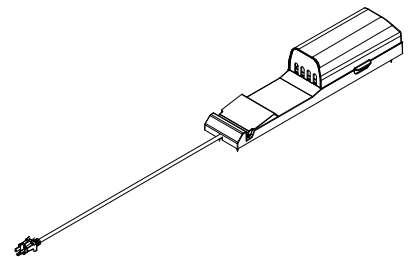

9220409 | ELECTRICAL
(x1) ENCLOSURE AUS

OWNER'S MANUAL - PARTS IDENTIFICATION

Accessory Components (Not to Scale)

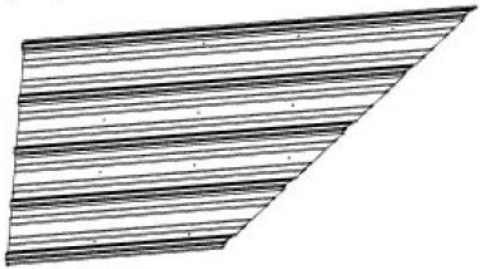

A4M02905-1 | 29 GA STEEL SHEETING
(x2)

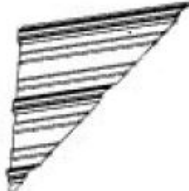

A4M02905-2 | 29 GA STEEL SHEETING
(x2)

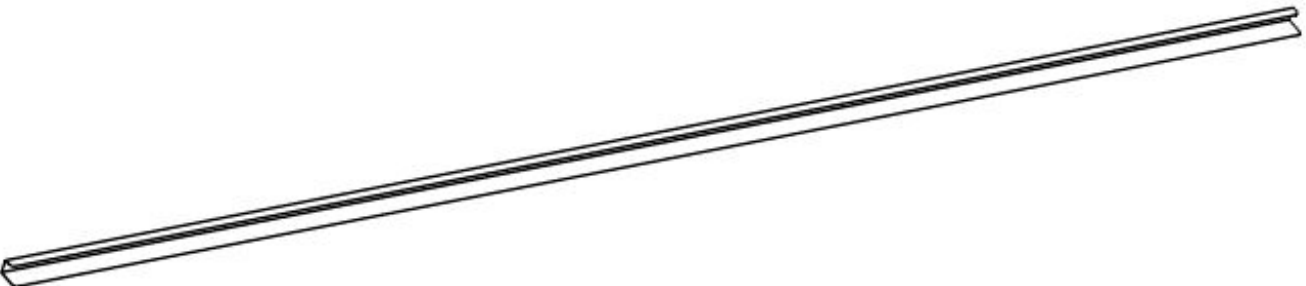

A4M02906 | RIDGE CAP CHANNEL
(x8)

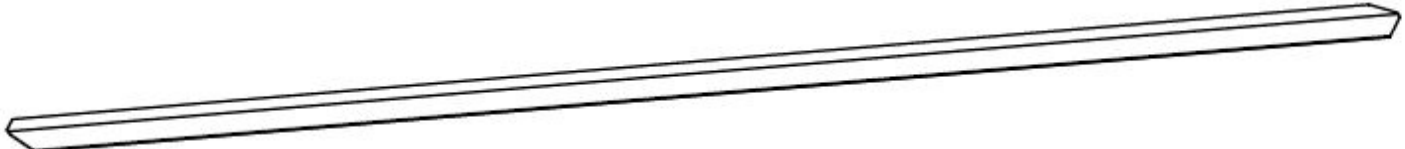

A4M02907 | CORNER RIDGE CAP
(x4)

PRE-ASSEMBLY STEP 1 - SORTING PARTS

It is critical for ease of assembly that you take the time to sort and organize the wood and hardware.

WOOD PARTS:

- Organize wood parts by the three-digit, alpha-numeric number stamped on each board (ex. P01).
- If there are multiple boards with the same stamped number, stack those pieces together.
- Stamps can be found on the flat surface of the boards or on the end of the boards.
- Allow yourself plenty of room - the wood pieces can take up a significant amount of space.

NOTE: CARTONS ARE NOT ORGANIZED BY BOARD NUMBER.

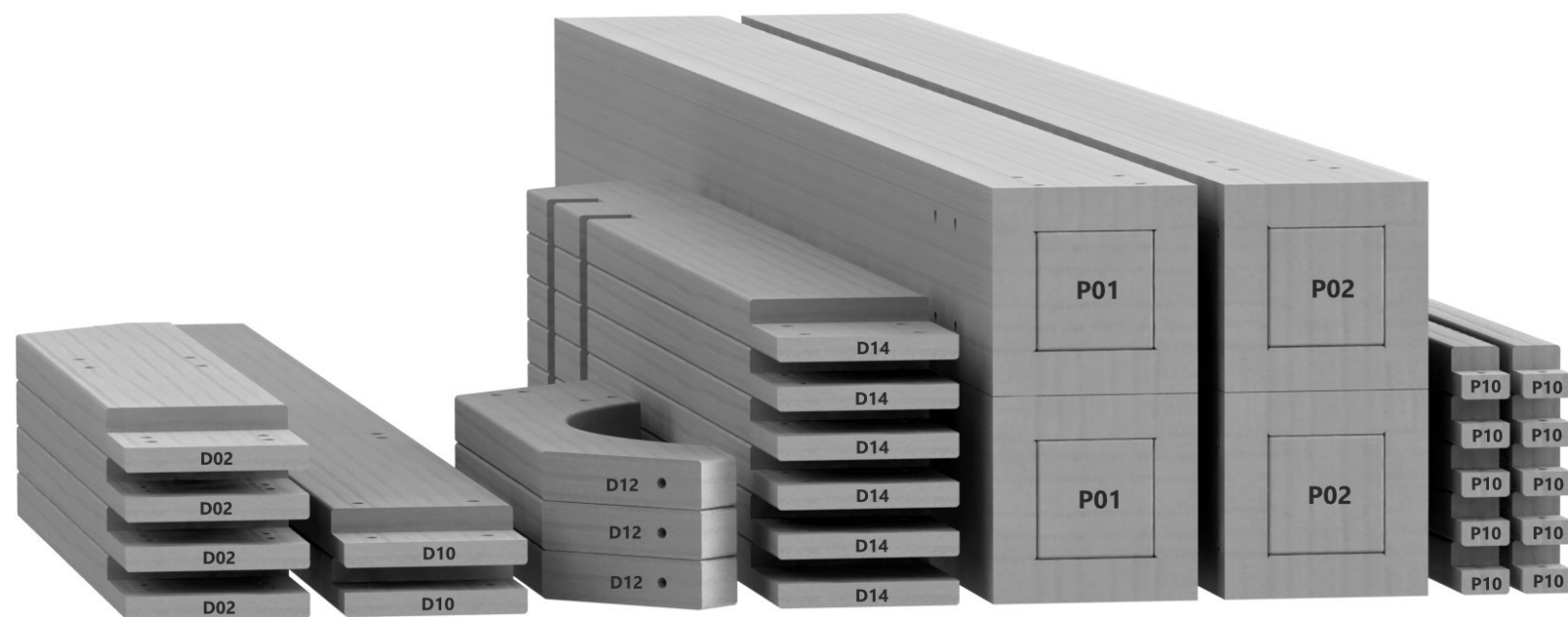

HARDWARE PARTS:

- We recommend that you have a separate table to organize the hardware.
- Hardware bags are printed with a seven-digit, alpha-numeric part number.
- You can organize your hardware by part number or group by hardware type (i.e. bolts, nuts, etc.).
- During assembly you only need to reference the last four digits of the number.

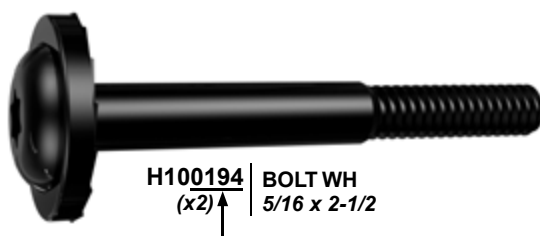

H100194 | BOLT WH
(x2) ↑ 5/16 x 2-1/2

PRE-ASSEMBLY STEP 2 - TOOLS REQUIRED



Cordless Drill or Electric Drill



Drill Attachments:
Phillips Head



1/8", 3/16", 3/8" & 7/16" Drill Bits



Phillips Screw Driver



Tape Measure



Claw Hammer



Open End Wrenches 1/2" & 7/16"



3/8" Drive Ratchet, 1/2" & 7/16" STD Sockets, 1/2" & 7/16" Deep Sockets



3/8 & 5/16" Nut Drivers

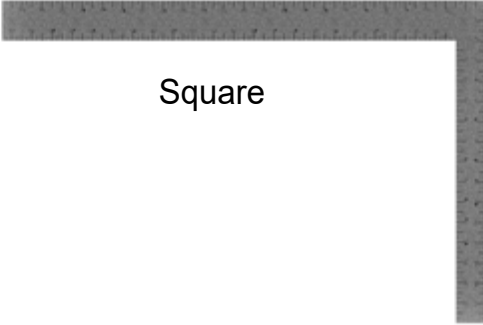

Square



Level 24"



Rubber Mallet - Optional



A6P00460 | QUICK RELEASE BAR CLAMP

PRE-ASSEMBLY STEP 3 - CHOOSE YOUR ASSEMBLY METHOD

There are several types of assembly instructions available to you.

1. Printed Assembly Manual included with your set
2. BILT APP - 3D interactive instructions
3. Combination of the Printed Manual and BILT APP (Note: Step numbers can differ between the two methods)



The graphic is a rectangular advertisement for the BILT app. At the top left is the BILT logo, which consists of a stylized hexagonal icon with a dot inside, followed by the word "BILT." in a bold, sans-serif font. To the right of the logo is a large QR code. Below the logo and QR code, the text "Scan for easy 3D instructions" is written in a large, bold, black font. Underneath this, in a smaller font, it says "Download the BILT app before you begin". To the right of this text are two buttons: "Download on the App Store" with the Apple logo and "GET IT ON Google Play" with the Google Play logo. At the bottom of the graphic is a smartphone screen displaying a 3D assembly instruction. The screen shows a grey 3D model of a structure with a horizontal beam and a triangular support. The interface includes a close button (X) in the top right, a menu icon (three dots) below it, a share icon (circle with a dot) below that, and a play/pause button (two vertical bars) at the bottom center. A small "Part(s) Needed" label is visible in the top left corner of the app interface.

STEP 1 - 10FT POST ASSEMBLY

Qty	PART NUMBER	DESCRIPTION
8	H100200	SCREW PFH 8x1 1/2 BLK



P01 POST - W2A03202
(x1) 6"x6"x89 1/2" (152x152x2274)



P02 POST - W2A03203
(x1) 6"x6"x89 1/2" (152x152x2274)

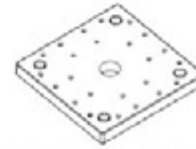

A6P00308 6x6 POST FOOT
(x2)

TIPS:

- FOR EASE OF ASSEMBLY, SAW HORSES ARE RECOMMENDED FOR STEPS 1 THOUGH 3.

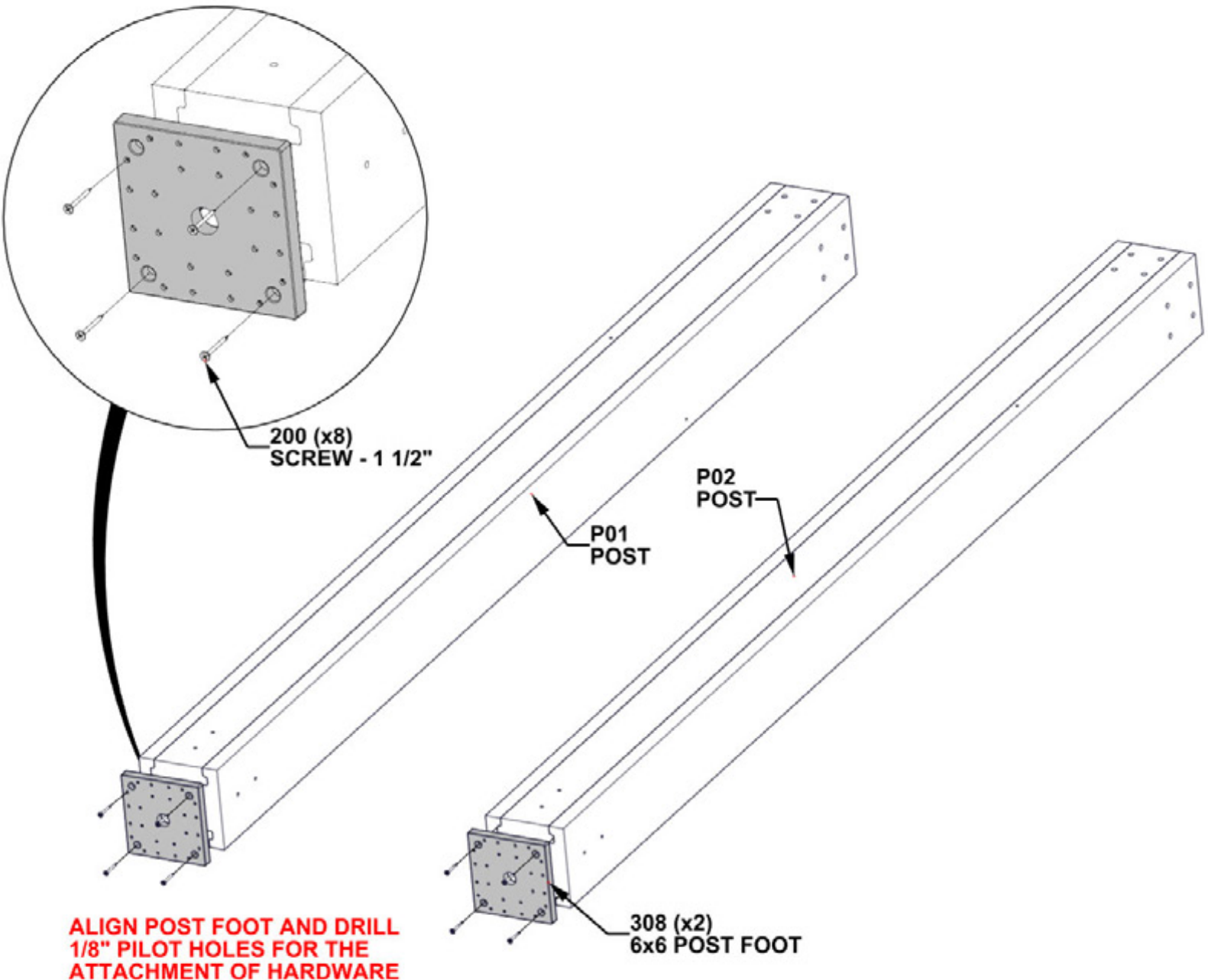

ALIGN POST FOOT AND DRILL 1/8" PILOT HOLES FOR THE ATTACHMENT OF HARDWARE

STEP 2 - 10FT BEAM ASSEMBLY



D02 BEAM - W4L16779
(x1) 36x5 1/4"x55 3/4" (36x134x1416)



D01 BEAM - W4L16778
(x2) 1 7/16"x5 1/4"x30 15/16" (36x134x786)

Qty	PART NUMBER	DESCRIPTION
8	H100195	BOLT WH 5/16x2 3/4 BLK
8	H100198	WASHER LOCK EXT 8X19 BLK
8	H100379	TNUT-5/16" BLK



C01 CORBEL - W2A03198
(x2) 1 7/16"x6 7/16"x36 1/4" (36x163x893)

INSERT T-NUTS FIRST

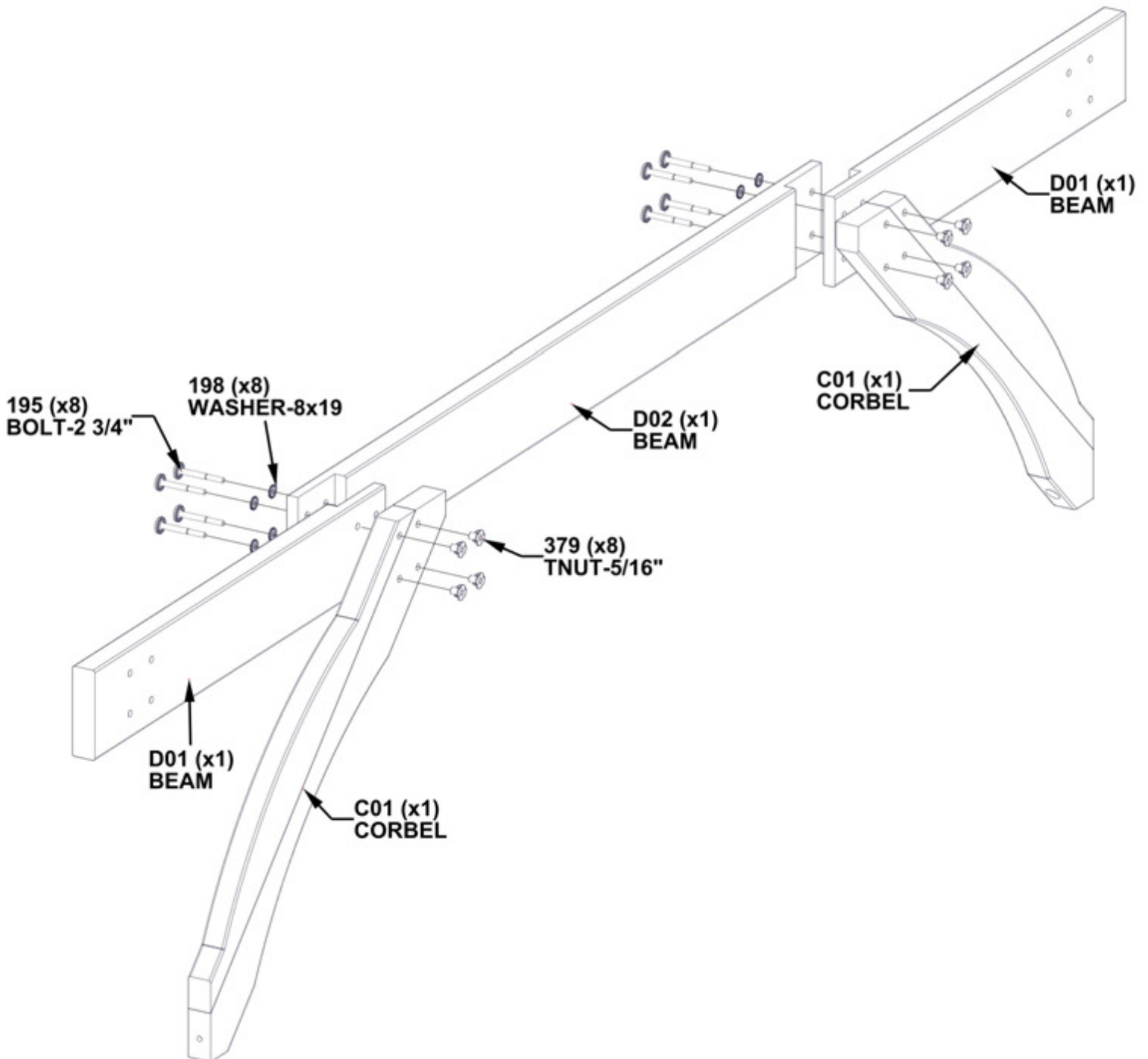

STEP 3 - 10FT BEAM ASSEMBLY

Qty	PART NUMBER	DESCRIPTION
8	H100196	BOLT WH 5/16x7 1/4 BLK
8	H100198	WASHER LOCK EXT 8X19 BLK
8	H100379	TNUT-5/16" BLK
2	H100405	WASHER LOCK EXT 6X15 BLK
2	H100792	LAG SCREW WH 1/4x3 BLK



INSERT T-NUTS FIRST

TIPS:

- TO AVOID WOOD SPLITTING, MAKE SURE LAG SCREWS GO INTO PILOT HOLES.
- SAW DUST CAN BE LEFT BEHIND IN BOLT HOLES. IF YOU HAVE TROUBLE WITH BOLTS ENGAGING, USE A LONG SCREWDRIVER TO REMOVE DEBRIS.

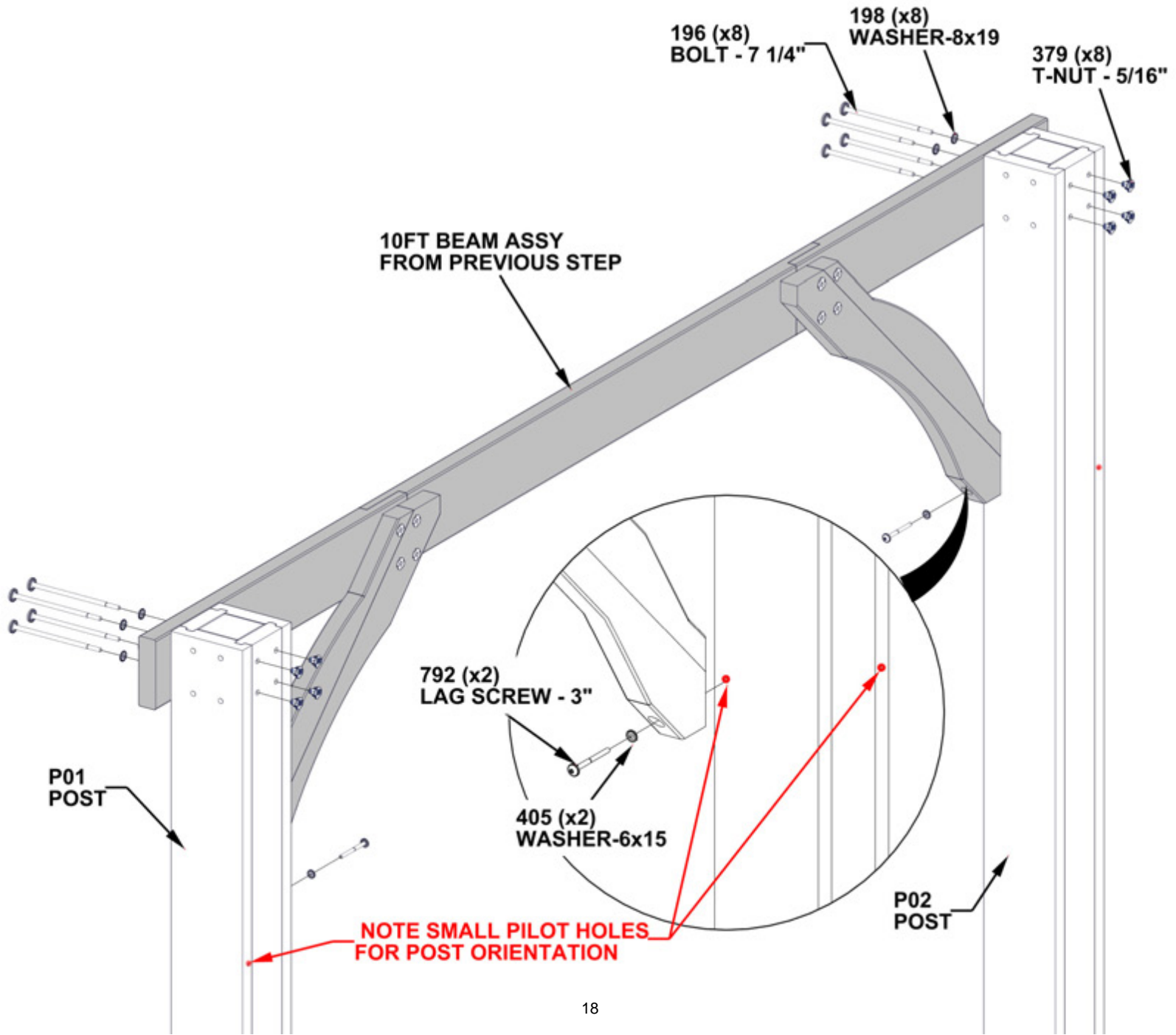

**SET 10FT ASSEMBLY TO THE SIDE
AND REPEAT STEPS 1 THROUGH 3**

STEP 4 - 12FT BEAM ASSEMBLY

Qty	PART NUMBER	DESCRIPTION
8	H100198	WASHER LOCK EXT 8X19 BLK
8	H100378	BOLT WH 5/16x1 3/4 BLK
8	H100379	T-NUT 5/16 BLK



G03 BEAM - W4L16777
 (x2) 15/16"x5 1/4"x65" (24x134x1651)



G02 BEAM - W4L16776
 (x1) 15/16"x5 1/4"x39 15/16" (24x134x1014)

INSERT T-NUTS FIRST

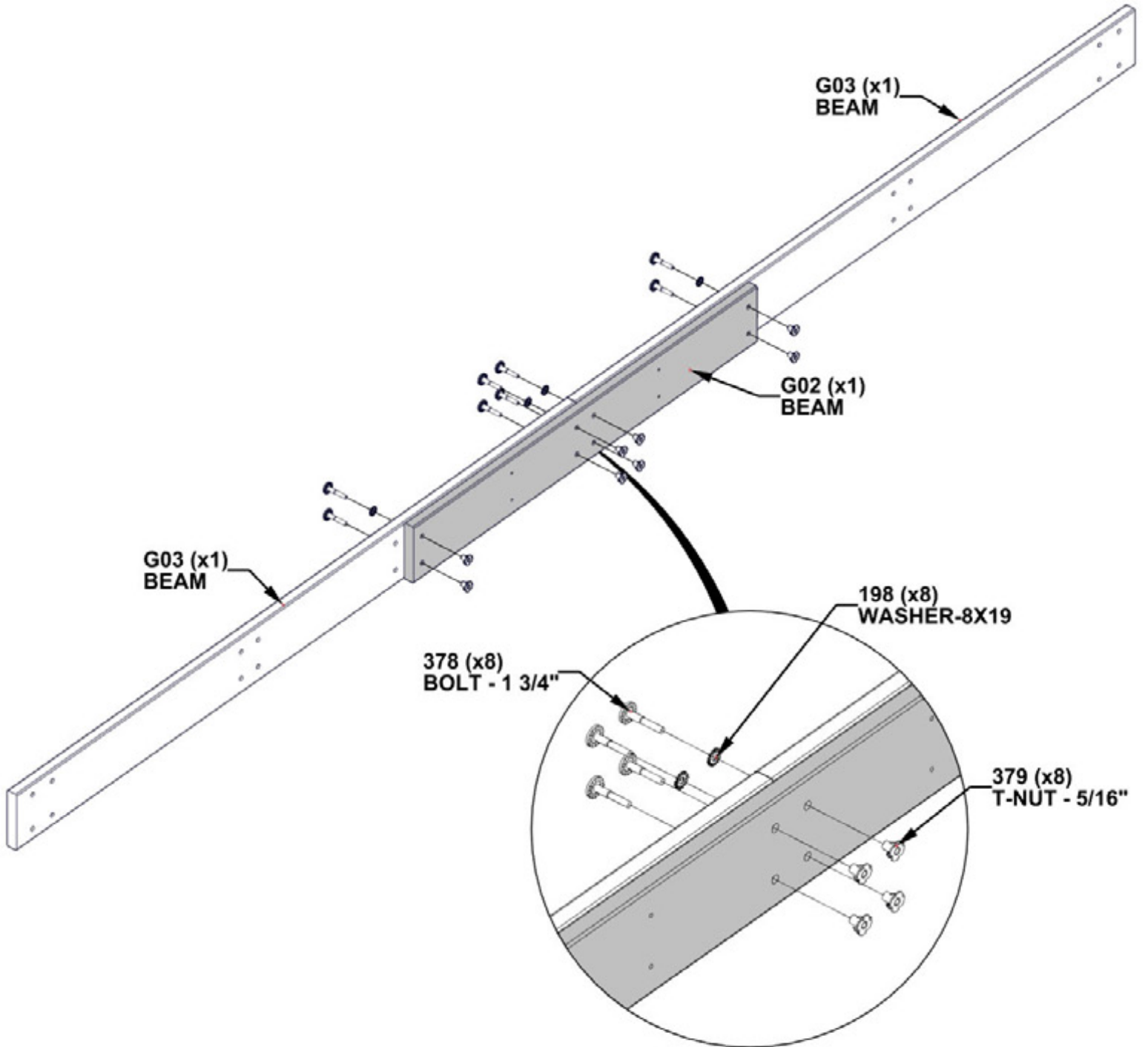

STEP 5 - 12FT BEAM ASSEMBLY

Qty	PART NUMBER	DESCRIPTION
12	H100198	WASHER LOCK EXT 8X19 BLK
4	H100378	BOLT WH 5/16x1 3/4 BLK
12	H100379	T-NUT 5/16 BLK
8	H100484	BOLT WH 5/16x3 1/4 BLK



G01 BEAM - W4L16775
(x2) 15/16"x5 1/4"x46" (24x134x1146)



C01 CORBEL - W2A03198
(x1) 1 7/16"x6 7/16"x36 1/4" (36x163x893)



C02 CORBEL W/TAG - W2A03199
(x1) 1 7/16"x6 7/16"x36 1/4" (36x163x893)

INSERT T-NUTS FIRST
CORBELS ARE TO BE HAND TIGHTENED ONLY

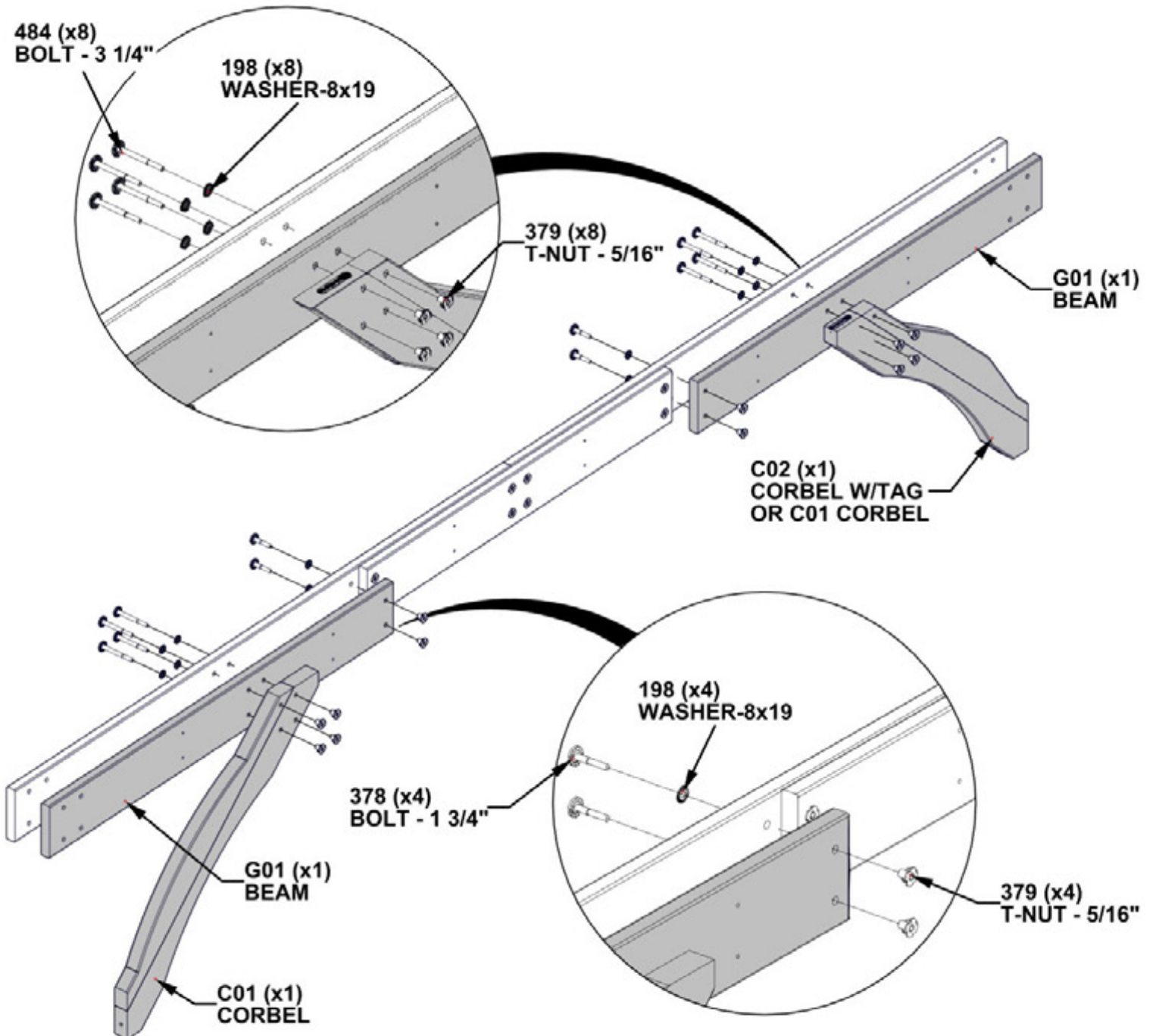

STEP 6 - 12FT BEAM ASSEMBLY

Qty	PART NUMBER	DESCRIPTION
12	H100382	SCREW PFH 8x1 3/4 BLK

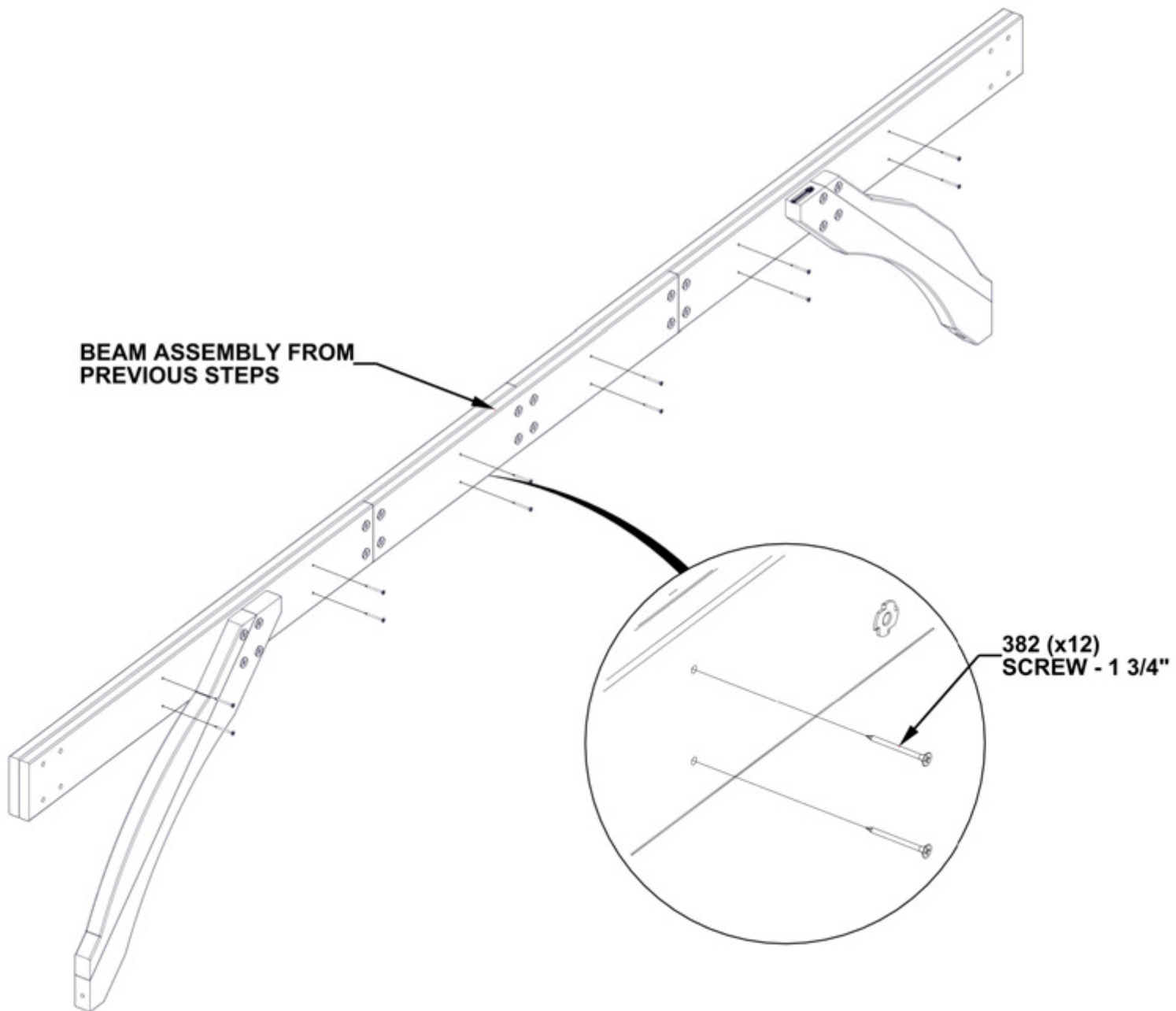
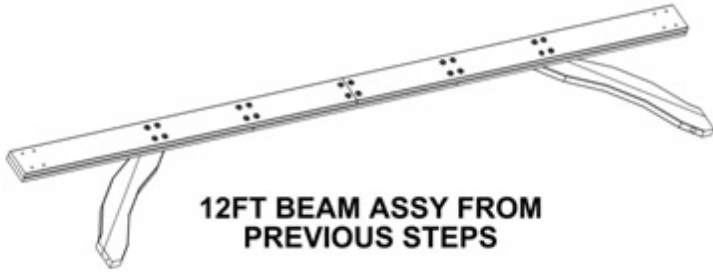

STEP 7 - 12FT BEAM ASSEMBLY

Qty	PART NUMBER	DESCRIPTION
8	H100198	WASHER LOCK EXT 8X19 BLK
8	H100379	T-NUT 5/16 BLK
2	H100405	WASHER LOCK EXT 6X15 BLK
2	H100792	LAG SCREW WH 1/4x3 BLK
8	H100963	BOLT WH 5/16x7 3/4 BLK

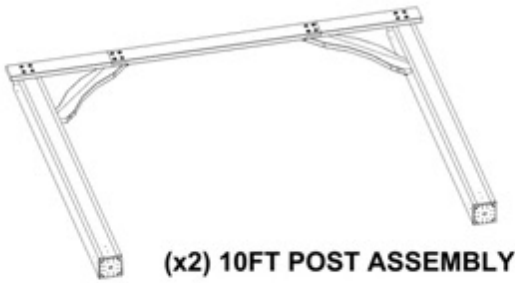

TIPS:

- THREE PEOPLE ARE HELPFUL FOR THIS STEP.
- MOVE THE 10FT POST ASSEMBLIES TO THEIR FINAL LOCATION WITH SOMEONE HOLDING EACH ASSEMBLY UPRIGHT.
- USING A THIRD PERSON, CONNECT THE 12FT BEAM ASSEMBLY TO THE POSTS TO MAKE THE GAZEBO FRAME.

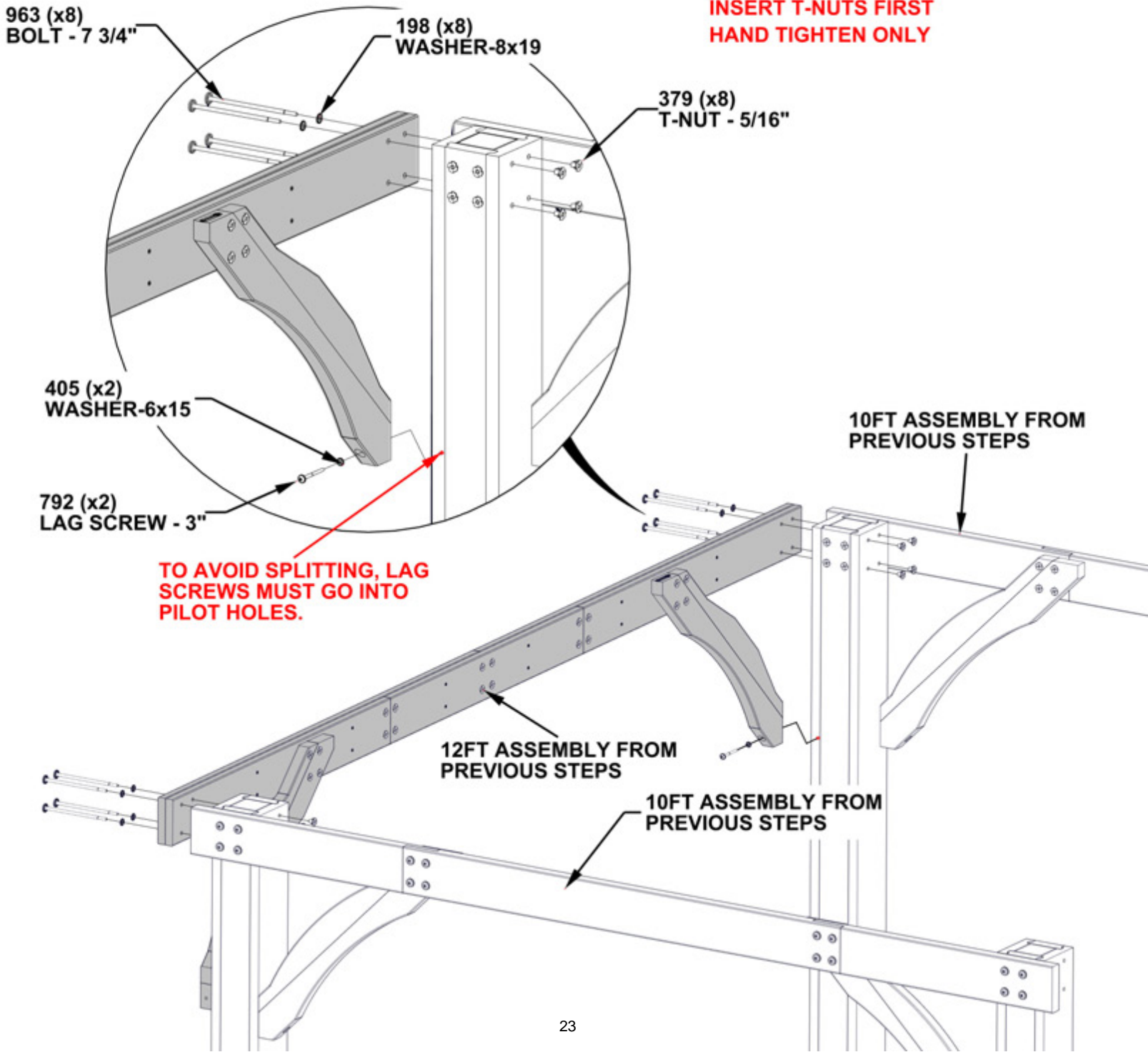

**REPEAT STEPS 4 THROUGH 7 FOR OPPOSITE
12FT BEAM ASSEMBLY**

STEP 8

**CRITICAL: SQUARE UNIT BEFORE PROCEEDING TO NEXT STEPS.
ONCE SQUARE, TIGHTEN ALL HARDWARE**

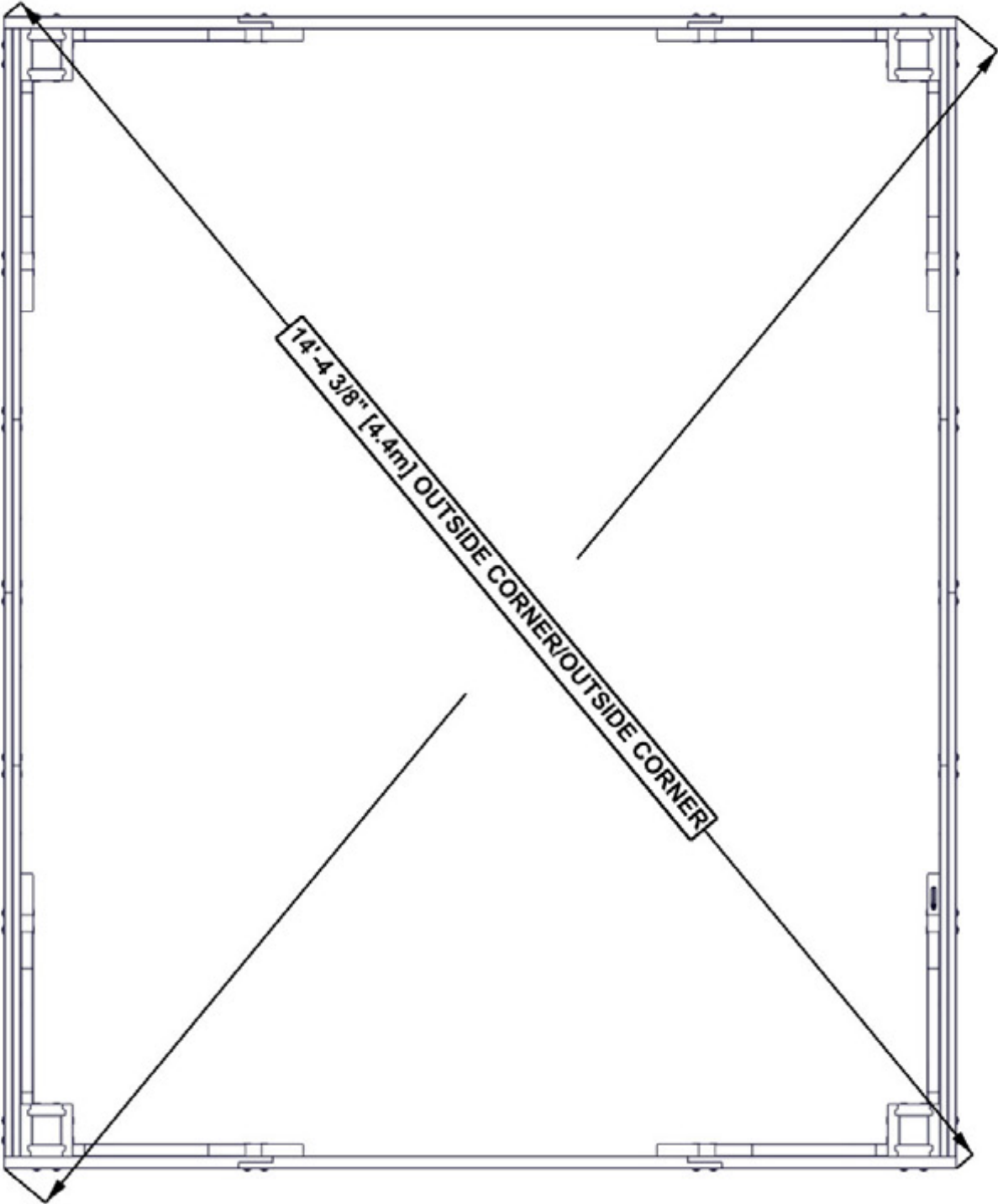

TOP VIEW

STEP 9 - ROOF SUPPORT ASSEMBLY

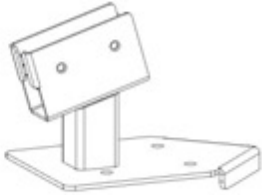

Qty	PART NUMBER	DESCRIPTION
16	H100460	LAG SCREW WH 1/4x1 BLK

A4M01234 POST CLIP
(x4)

REPEAT ON ALL FOUR POSTS
DO NOT OVERTIGHTEN

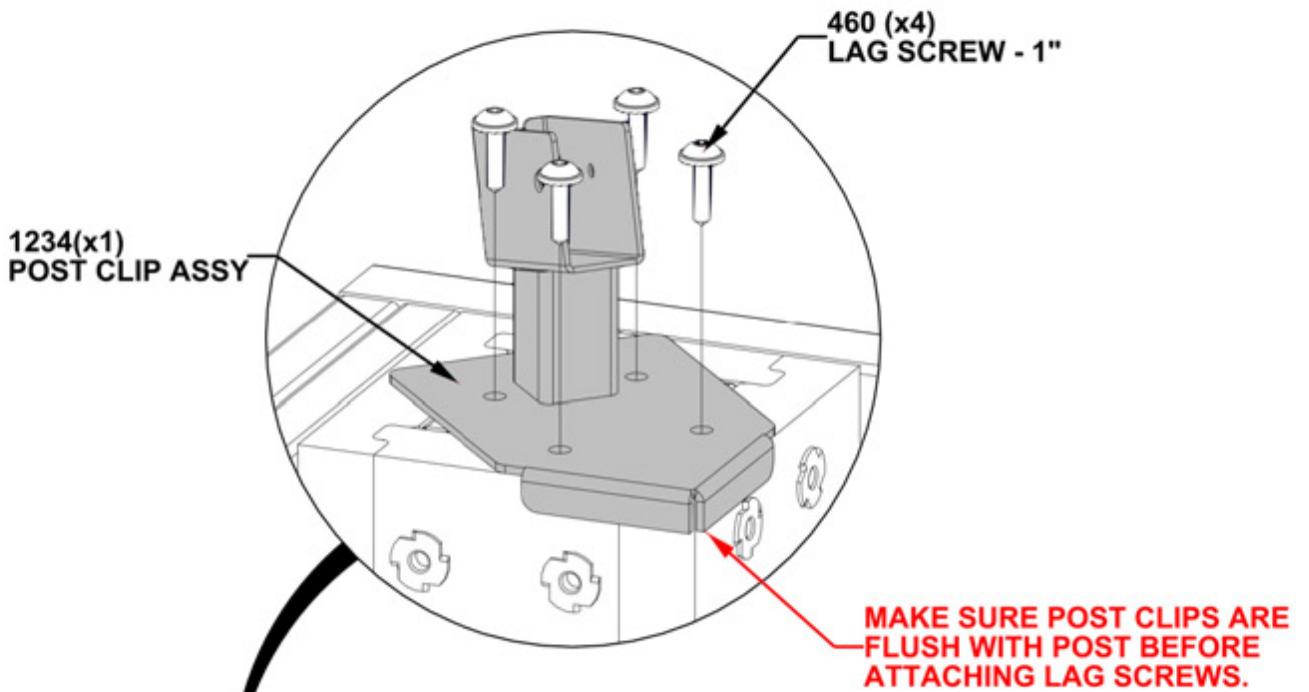

STEP 10 - ROOF SUPPORT ASSEMBLY

Qty	PART NUMBER	DESCRIPTION
2	H100379	T-NUT 5/16 BLK
8	H100385	SCREW PFH 8x1 BLK



H29 ROOF SUPPORT - W4L15160
(x1) 15/16"x3 3/8"x24" (24x86x610)

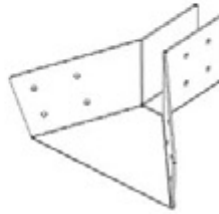

A4M01184 PANEL SUPPORT BRACKET
(x2)

INSERT T-NUTS FIRST

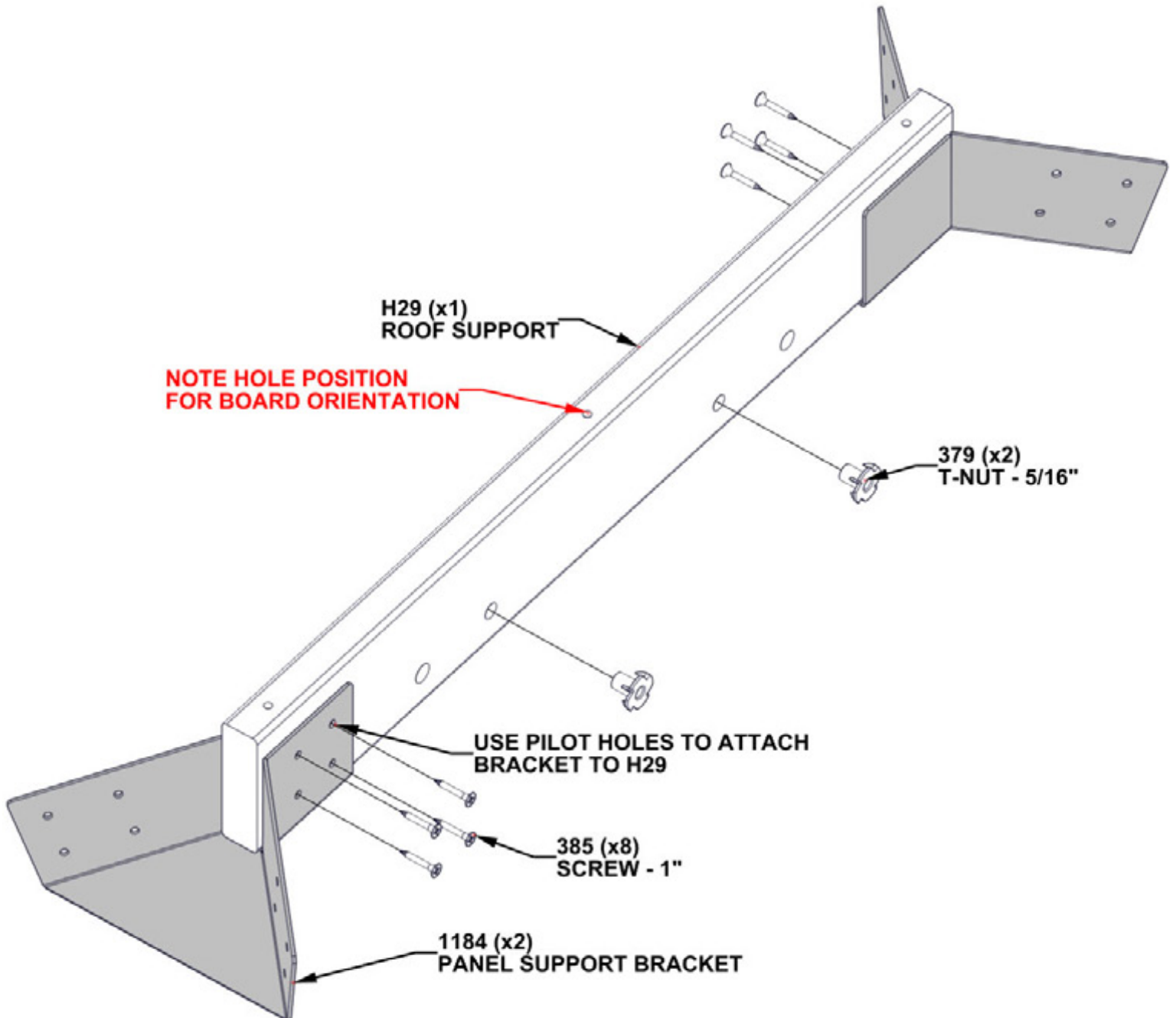

STEP 11 - ROOF SUPPORT ASSEMBLY

Qty	PART NUMBER	DESCRIPTION
4	H100379	T-NUT 5/16 BLK
16	H100385	SCREW PFH 8x1 BLK



H01 ROOF SUPPORT - W4L16781
 (x4) 15/16"x3 3/8"x75 3/16" (24x86x1909)

INSERT T-NUTS FIRST

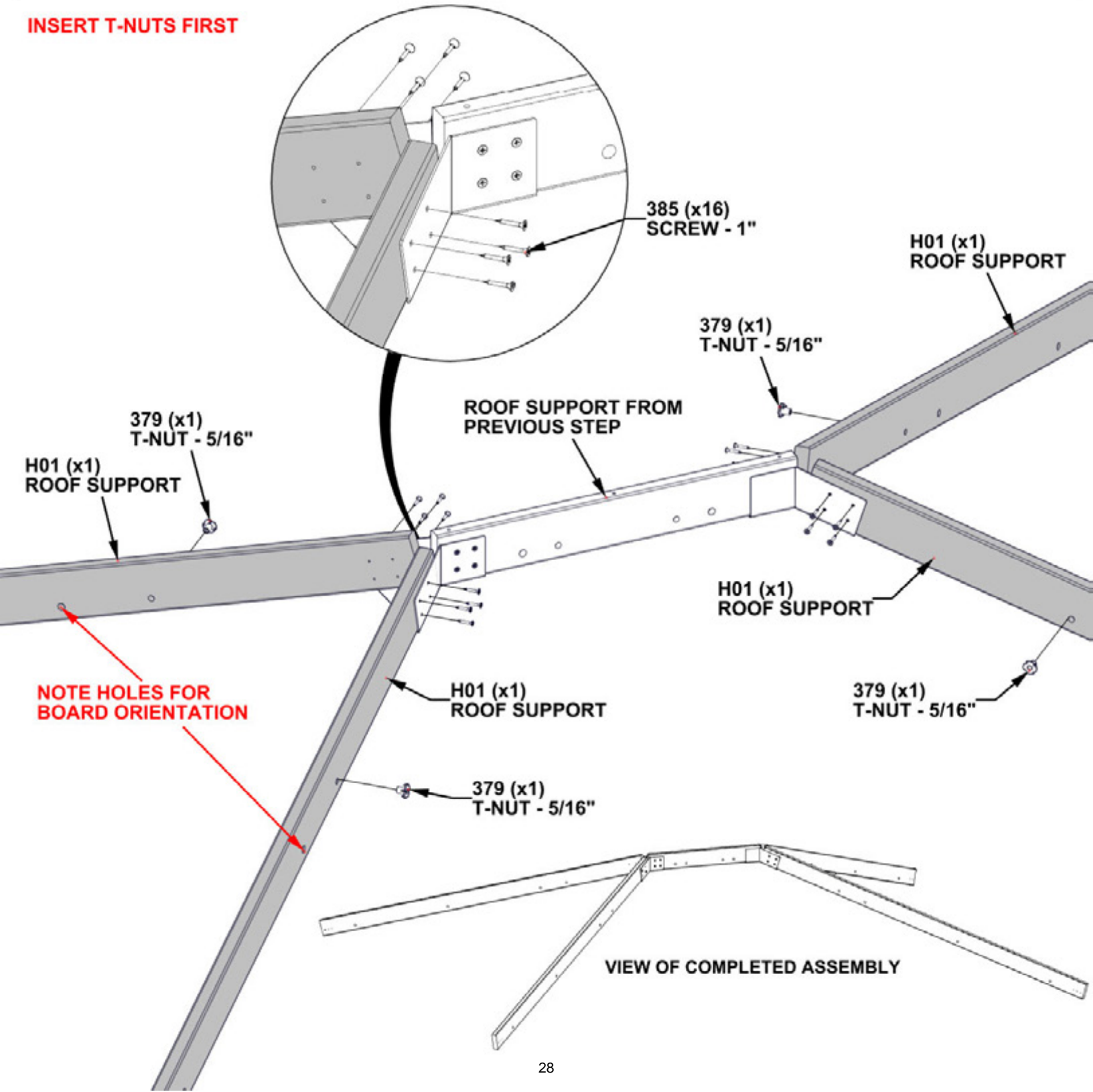

STEP 12 - ROOF SUPPORT ASSEMBLY

Qty	PART NUMBER	DESCRIPTION
3	H100792	LAG SCREW WH 1/4x3 BLK
3	H101034	WEATHER PROOFING WASHER



A4M02886 PEAK RIDGE CAP
(x1)

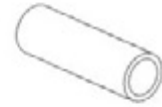

A4M01205 METAL SPACER
(x3)

TIPS:
 • REMOVE PROTECTIVE BLUE FILM BEFORE ASSEMBLY

WARNING: GLOVES ARE RECOMMENDED WHEN HANDLING STEEL ROOF PIECES

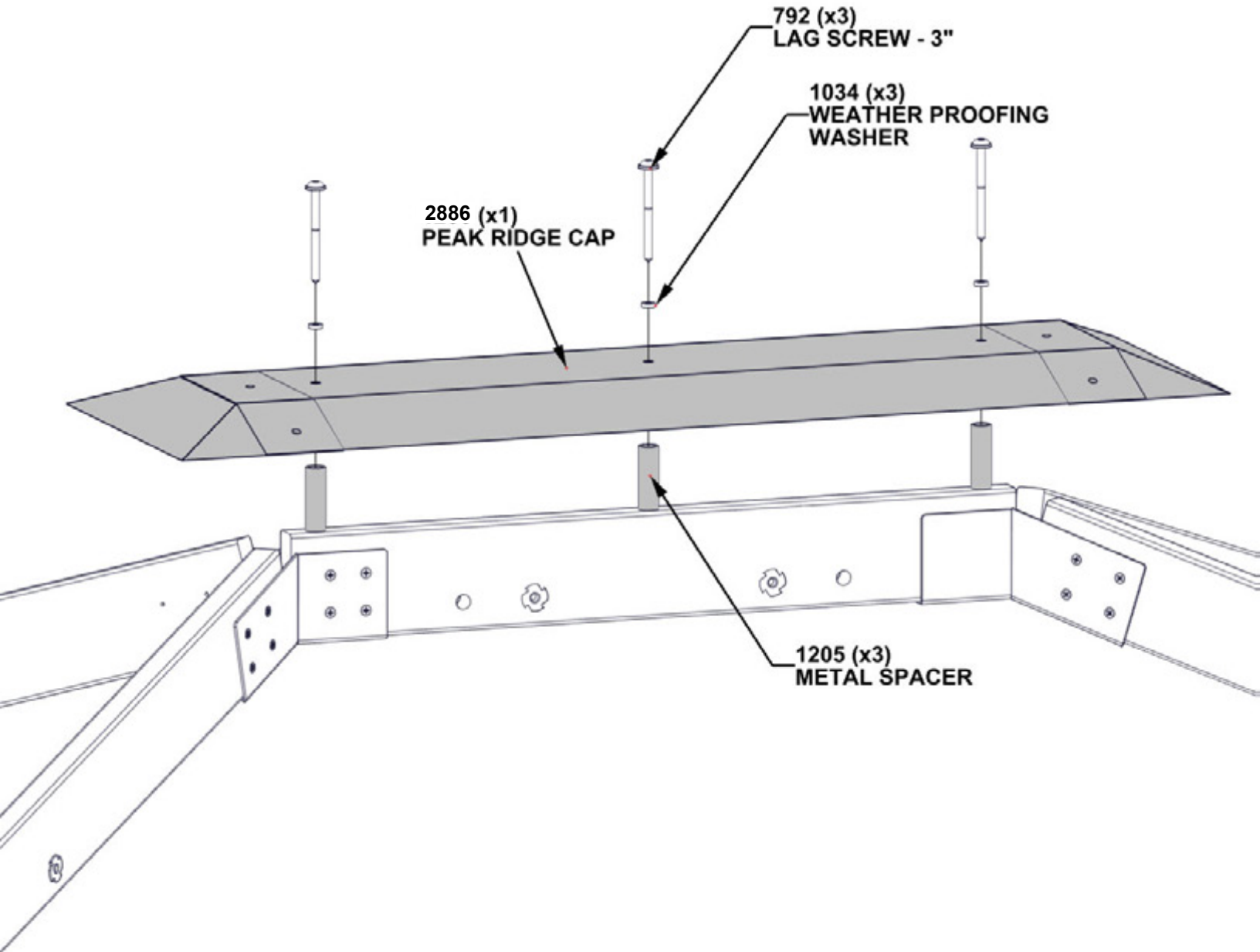

STEP 13 SUPPORT ASSEMBLY

- THREE PEOPLE ARE HELPFUL FOR THIS STEP.
- POSITION A PERSON ON A LADDER IN THE CENTER OF THE BASE.
- LIFT ROOF SUPPORT UP AND OVER THE 12FT SIDE AND INSERT INTO CORNER POST CLIPS.

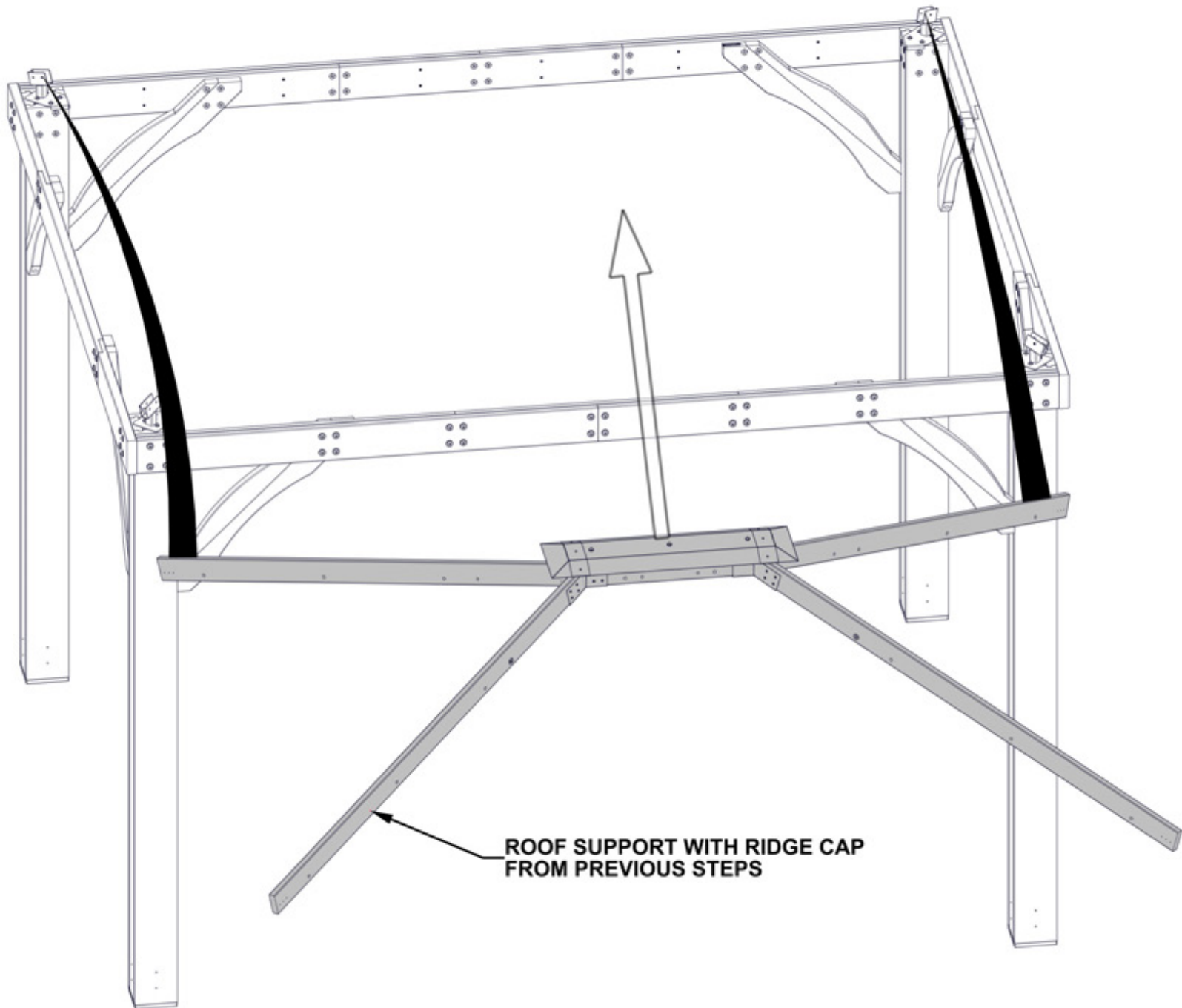

STEP 14 ROOF SUPPORT ASSEMBLY

Qty	PART NUMBER	DESCRIPTION
12	H100385	SCREW PFH 8x1 BLK

REPEAT ON ALL POSTS

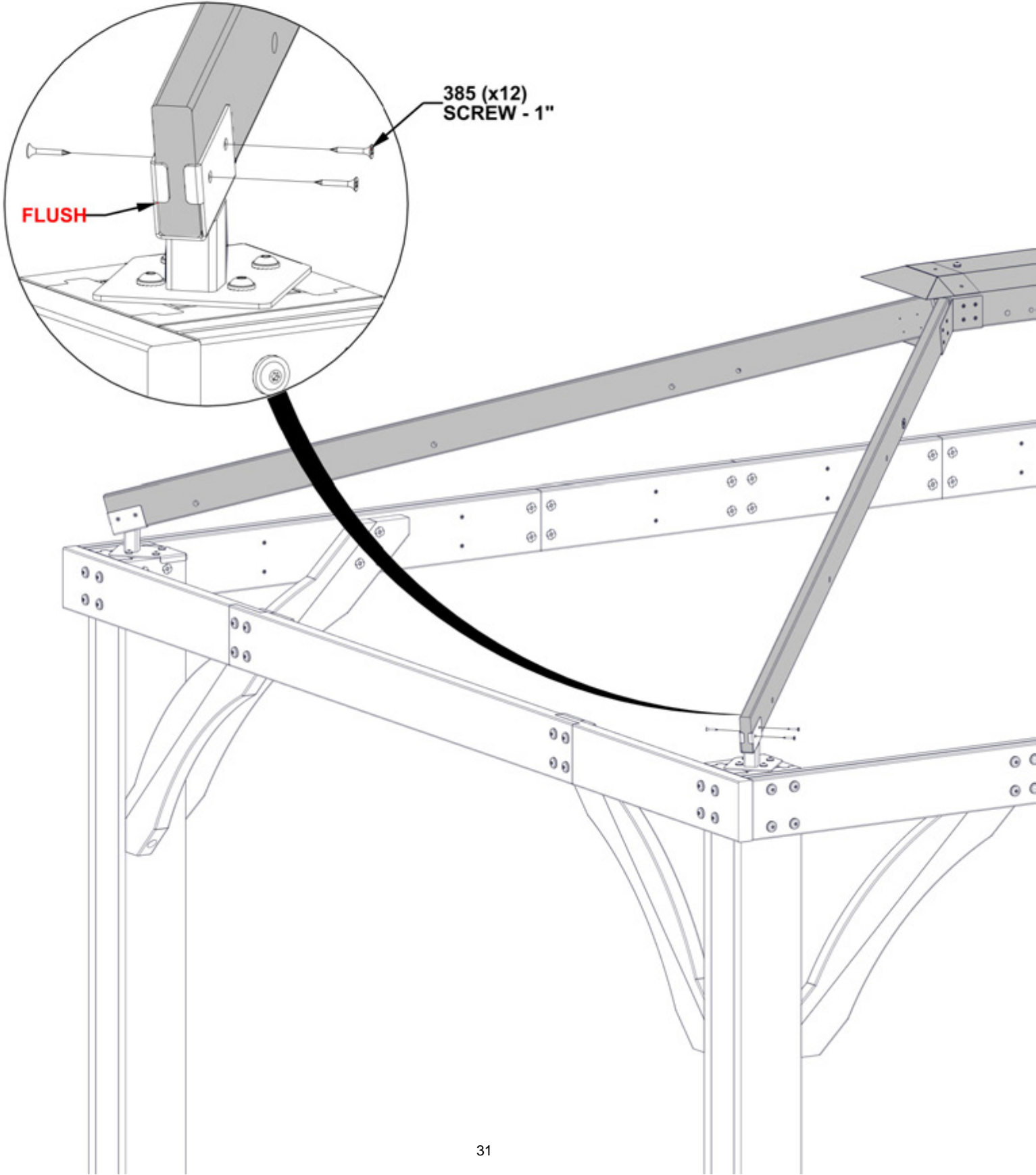

STEP 15 - 12FT ROOF PANEL ASSEMBLY

Qty	PART NUMBER	DESCRIPTION
4	H100171	BOLT WH 1/4x1 BLK
4	H100398	TNUT-1/4" BLK



H02 ROOF JOIST - W4L16782
(x1) 15/16"x3 3/8"x25 9/16" (24x86x648)

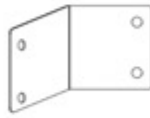

A4M01667 PANEL BRACKET
(x1)

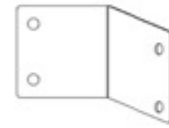

A4M01666 PANEL BRACKET
(x1)

**INSERT T-NUTS FIRST
HAND TIGHTEN ONLY**

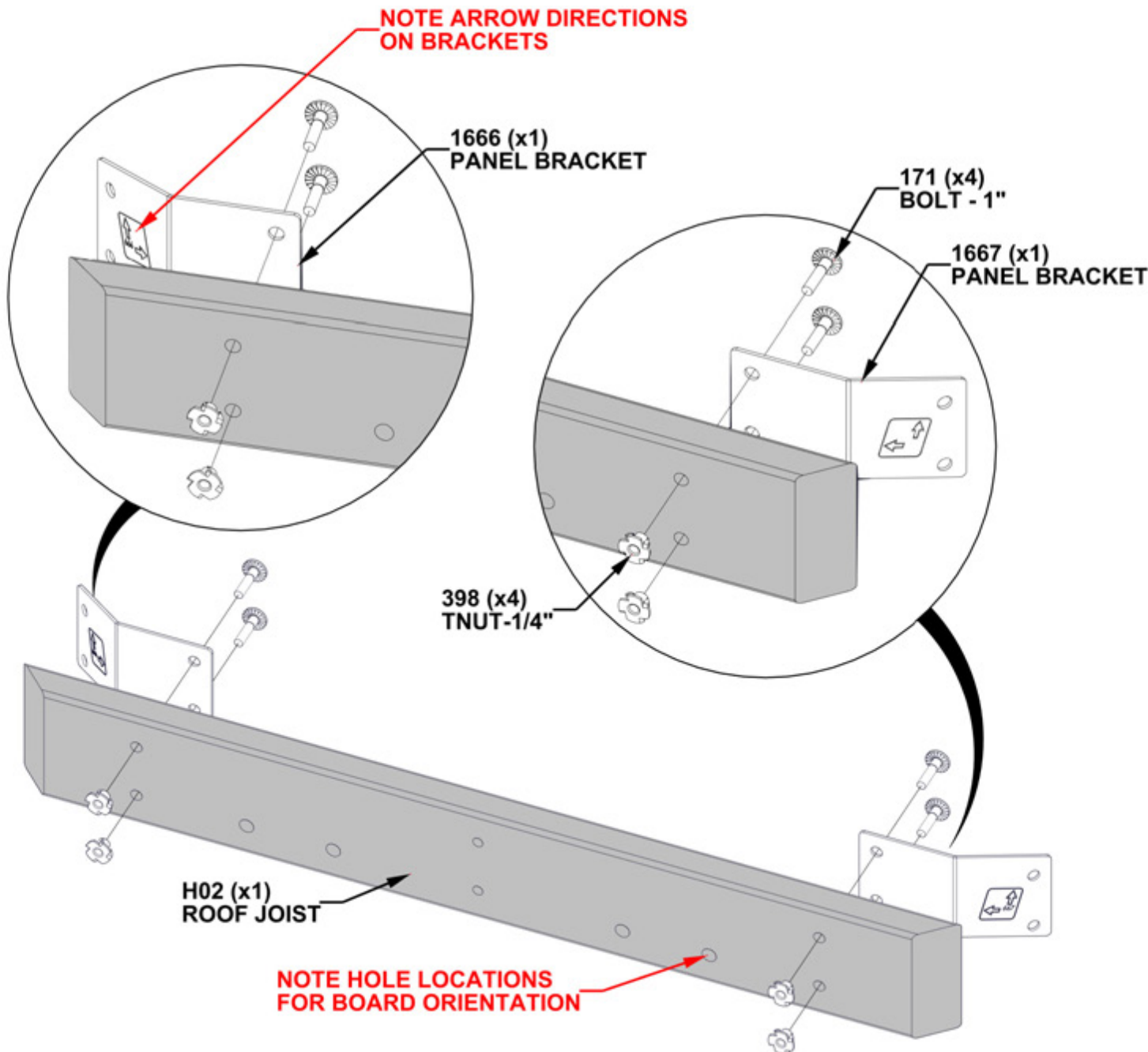

STEP 16 - 12FT ROOF PANEL ASSEMBLY

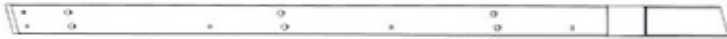

H03 ROOF JOIST - W4L16783
(x1) 15/16"x3 3/8"x86 3/4" (24x86x2203)

Qty	PART NUMBER	DESCRIPTION
4	H100171	BOLT WH 1/4x1 BLK
4	H100398	TNUT-1/4" BLK



H04 ROOF JOIST - W4L16784
(x1) 15/16"x3 3/8"x85 3/4" (24x86x2203)

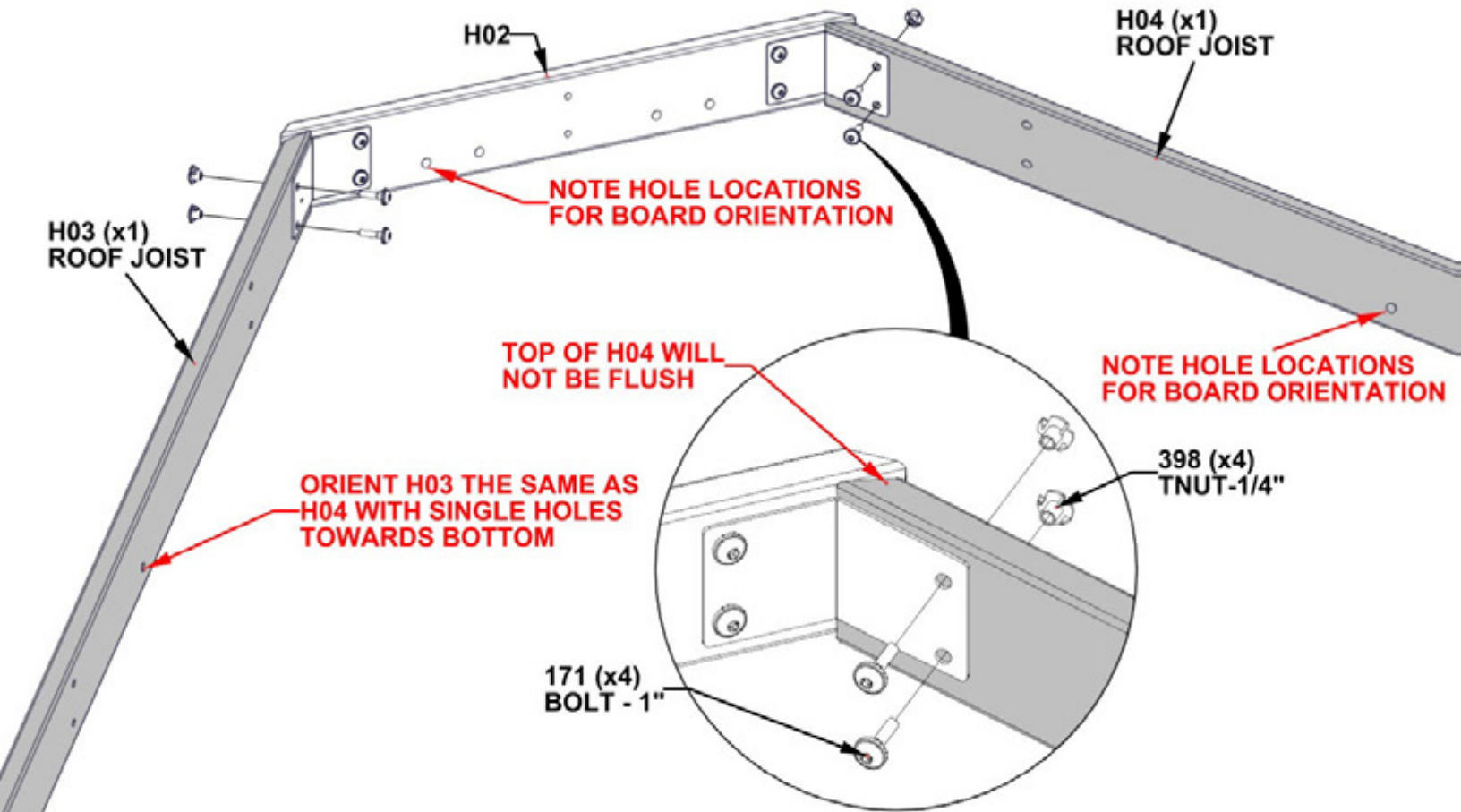
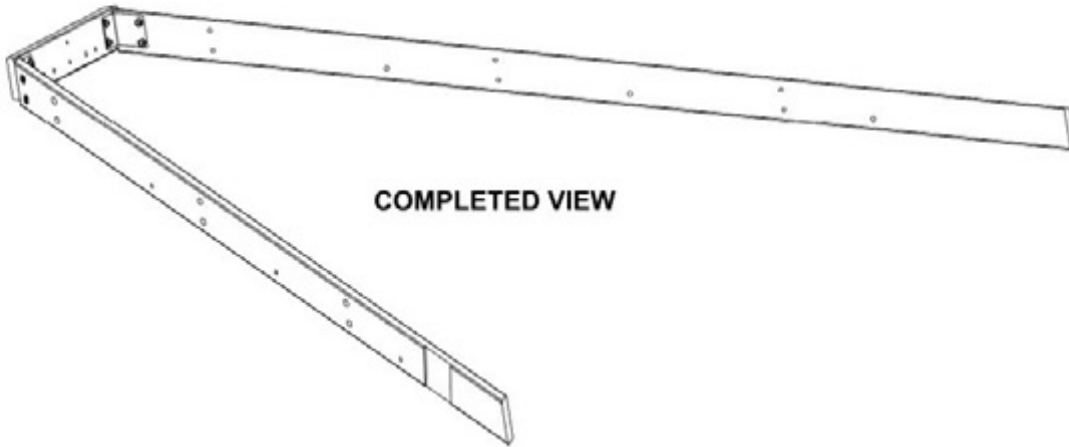

STEP 17A - 12FT ROOF PANEL ASSEMBLY

Qty	PART NUMBER	DESCRIPTION
6	H101030	SCREW CONFIRMAT 7x2 BLK



E03 RAFTER - W4L16788
(x1) 1 7/16"x3 3/8"x58 1/8" (36x86x1477)



E05 RAFTER - W4L16790
(x1) 1 7/16"x3 3/8"x58 1/8" (36x86x1477)



E04 RAFTER - W4L16789
(x1) 1 7/16"x3 3/8"x63 11/16" (36x86x1617)

1030 (x6)
CONFIRMAT SCREW - 2"

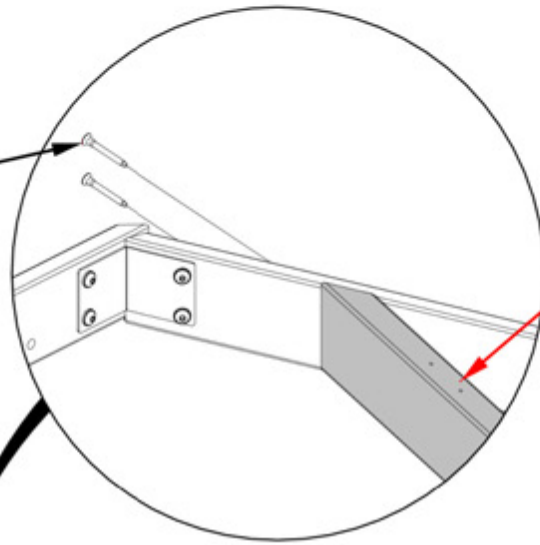

NOTE PILOT HOLES ARE TO FACE UP ON ALL RAFTERS

NOTE HOLE LOCATIONS FOR BOARD ORIENTATION

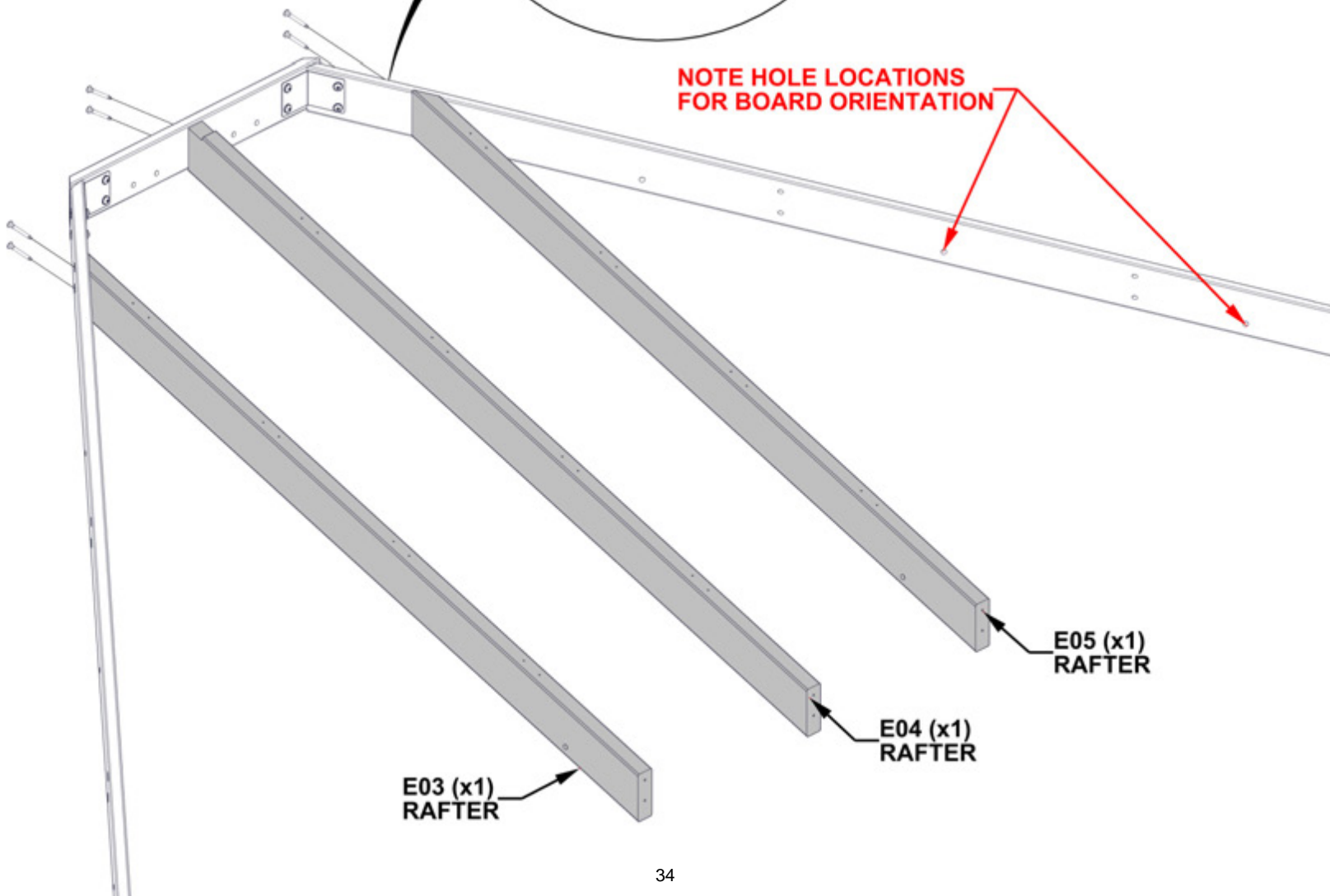

E05 (x1)
RAFTER

E04 (x1)
RAFTER

E03 (x1)
RAFTER

STEP 17B - 12FT ROOF PANEL ASSEMBLY

Qty	PART NUMBER	DESCRIPTION
8	H101030	SCREW CONFIRMAT 7x2 BLK

E01 RAFTER - W4L16786
(x1) 1 7/16"x3 3/8"x20 13/16" (36x86x528)

E02 RAFTER - W4L16787
(x1) 1 7/16"x3 3/8"x39 7/16" (36x86x1002)

E06 RAFTER - W4L16791
(x1) 1 7/16"x3 3/8"x39 7/16" (36x86x1002)

E07 RAFTER - W4L16792
(x1) 1 7/16"x3 3/8"x20 13/16" (36x86x528)

030 (x8)
CONFIRMAT SCREW - 2"

NOTE PILOT HOLES ARE TO FACE UP ON ALL RAFTERS

NOTE HOLE LOCATIONS FOR BOARD ORIENTATION

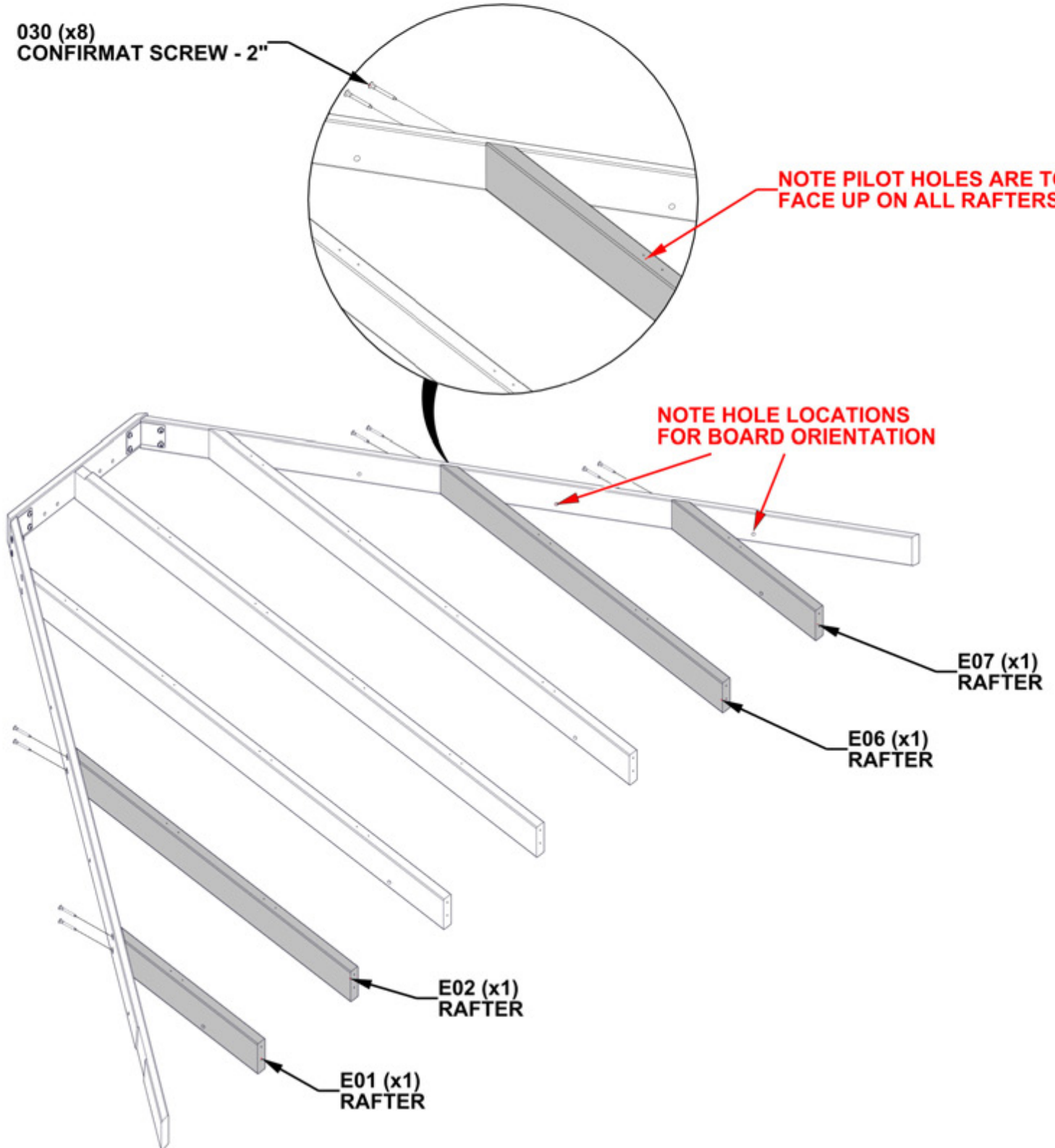

STEP 18A - 12FT ROOF PANEL ASSEMBLY

Qty	PART NUMBER	DESCRIPTION
4	H100382	SCREW PFH 8x1 3/4 BLK
14	H101030	SCREW CONFIRMAT 7x2 BLK

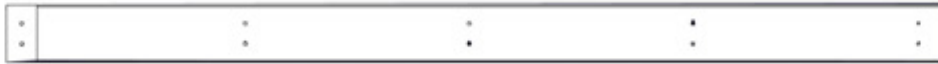

Q01 ROOF JOIST - W4L16785
 (x2) 15/16"4 7/16"72 1/4" (24x112x1835)

TIP:
 • RAFTERS MAY NEED TO BE LOOSENED TO ATTACH Q01 TO H03/H04

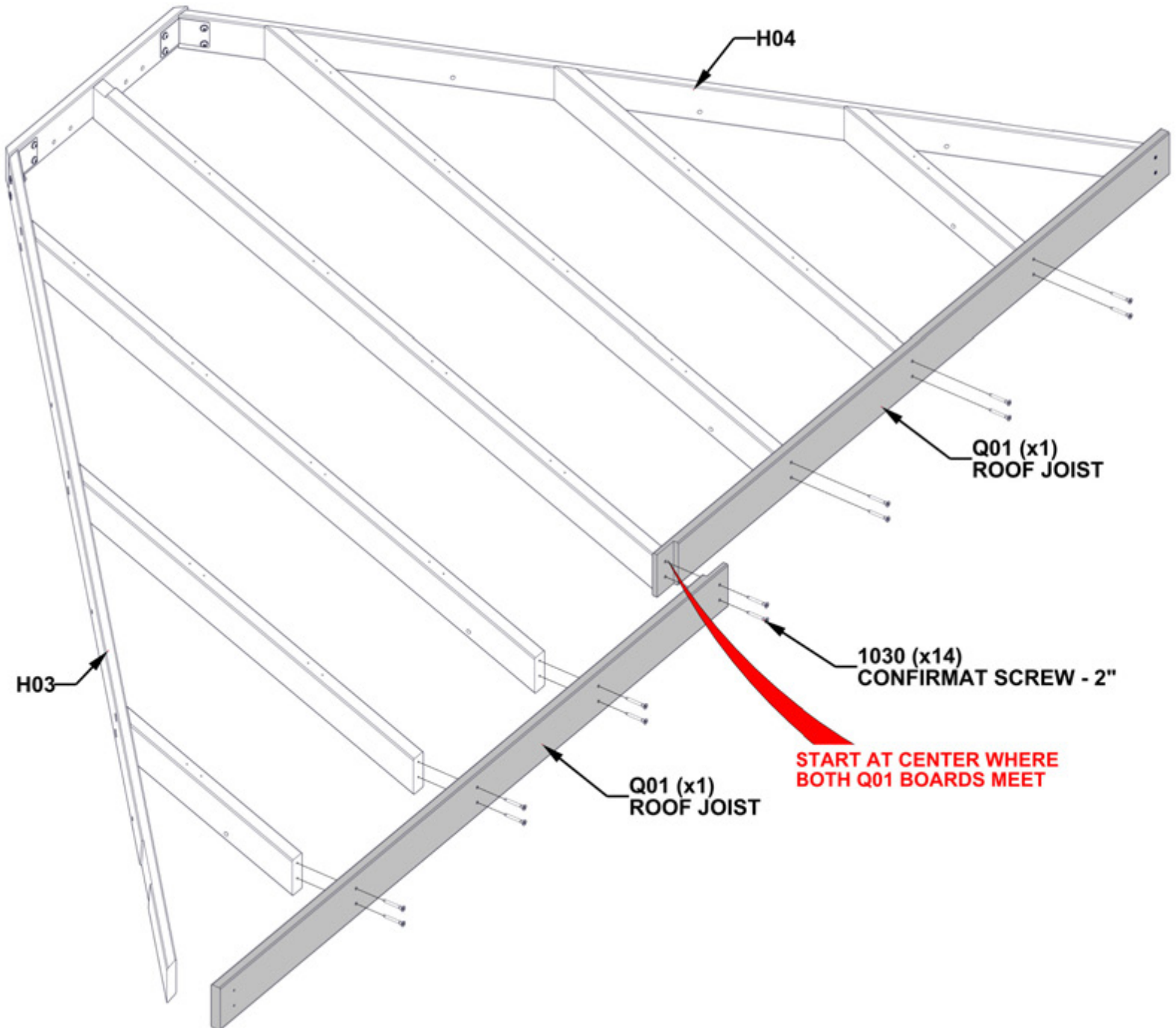

STEP 18B - 12FT ROOF PANEL ASSEMBLY

TIPS:

- USING THE Q01 BOARD AS A GUIDE AND A 1/8" DRILL BIT, DRILL PILOT HOLES INTO THE H03 BOARDS USING THE DIMENSION BELOW.
- REPEAT ON OPPOSITE END WITH H04 BOARD.

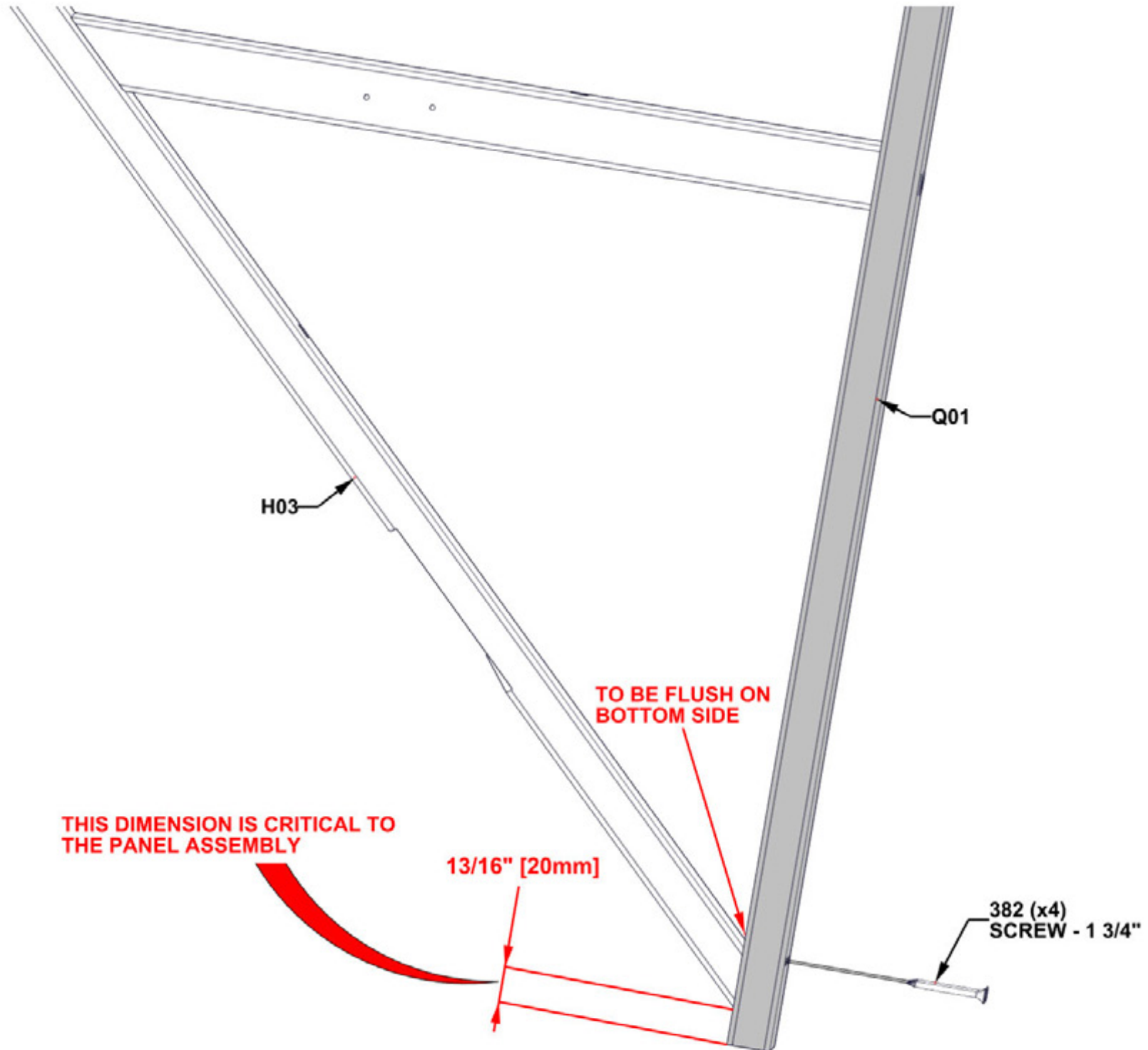

STEP 18C - 12FT ROOF PANEL ASSEMBLY

- TIP:
- LOOSEN HARDWARE TO ADJUST FOR SQUARING IF NEEDED

CRITICAL:

- SQUARE UNIT BEFORE PROCEEDING TO NEXT STEPS.
- THE BELOW DIMENSIONS ARE CRITICAL TO THE FINAL ROOF ASSEMBLY.
- MEASUREMENTS SHOULD BE WITHIN $\pm 1/4$ "
- MEASUREMENTS OUTSIDE OF TOLERANCE WILL LEAD TO THE INABILITY TO ASSEMBLE THE ROOF.
- TIGHTEN ALL HARDWARE.

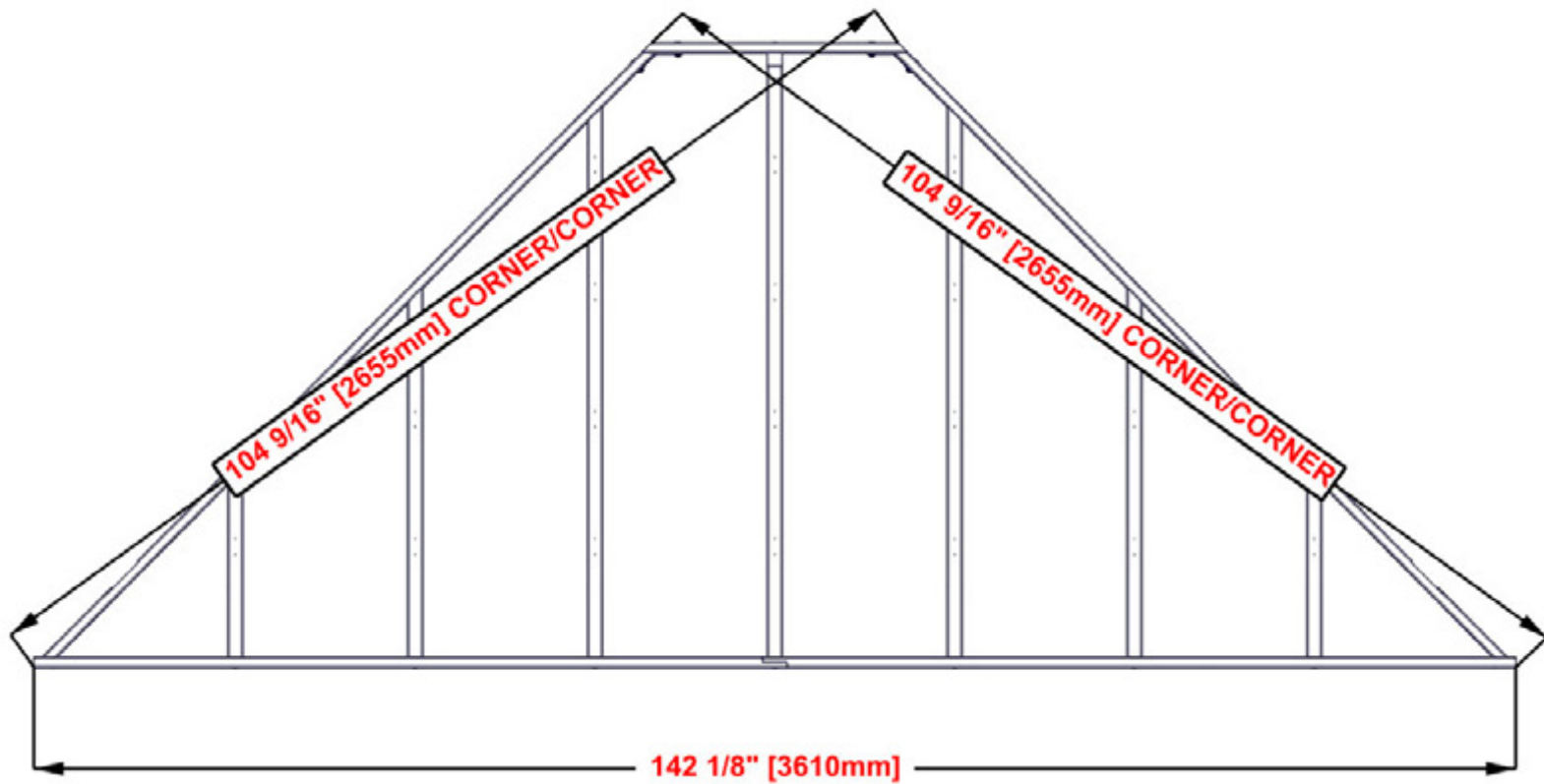

STEP 19A - 12FT ROOF PANEL ASSEMBLY

T01 PURLIN - W4L16799
(x1) 15/16"x1 5/16"x27 7/8" (24x34x708)

Qty	PART NUMBER	DESCRIPTION
22	H100391	SCREW PFH 8x2 BLK

H10 PURLIN - W4L16798
(x1) 15/16"x3 3/8"x51 1/8" (24x86x1299)

H09 PURLIN - W4L16797
(x1) 15/16"x3 3/8"x75 1/4" (24x86x1912)

TIPS:

- ALIGN PURLIN PILOT HOLES WITH RAFTER PILOT HOLES.
- ATTACH SCREWS FROM THE CENTER AND WORK OUTWARDS.
- H03/H04 BOARDS DO NOT HAVE PILOT HOLES FOR OUTSIDE EDGE BOARDS.
- USING THE PURLINS AS A GUIDE AND A 1/8" DRILL BIT, DRILL PILOT HOLES INTO H03/H04 BOARDS.

IF PURLINS OVERHANG MORE THAN 5/8", CUT DOWN TO 5/8"

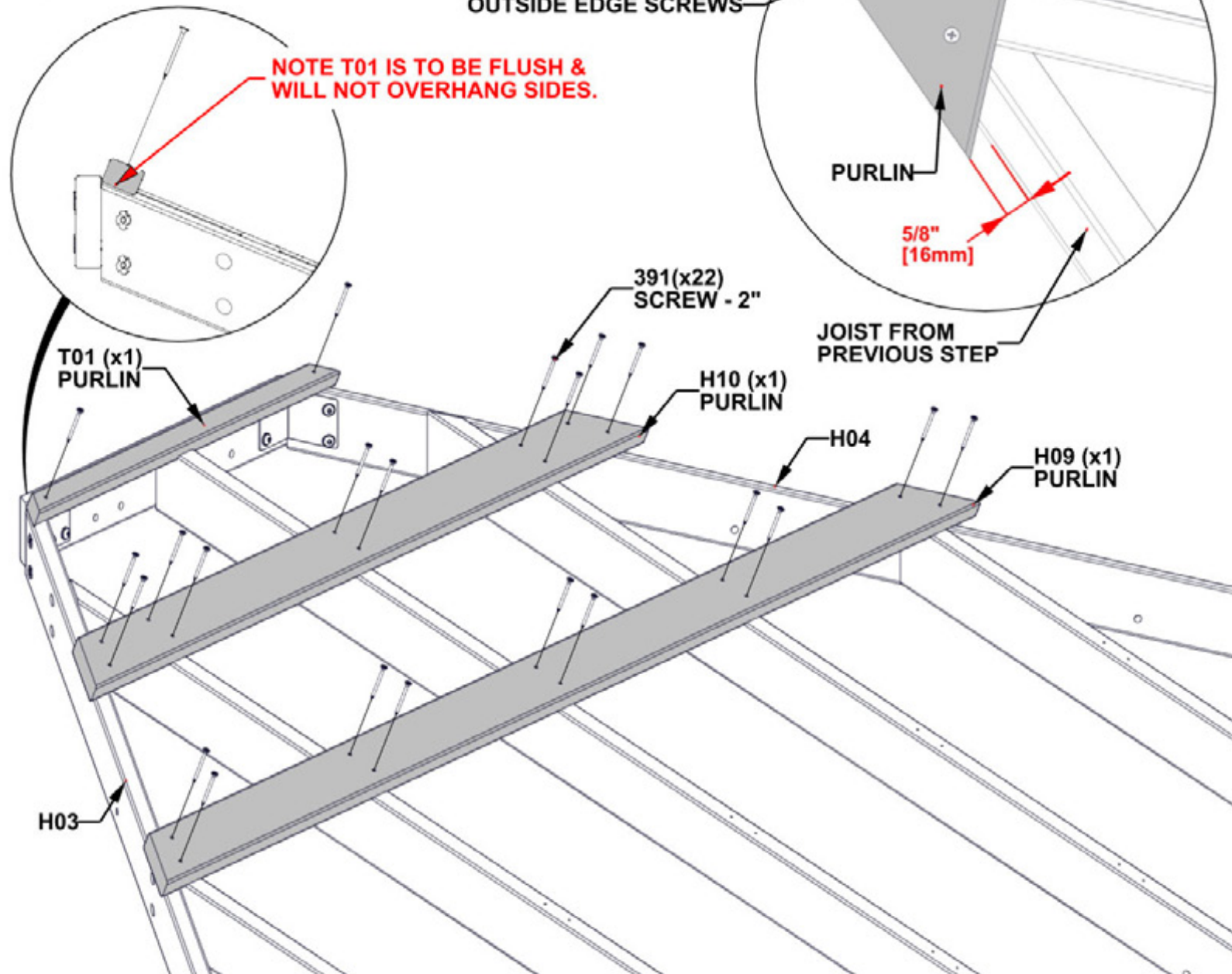

STEP 19B - 12FT ROOF PANEL ASSEMBLY

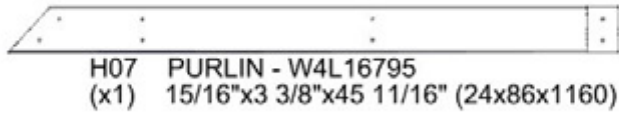

Qty	PART NUMBER	DESCRIPTION
32	H100391	SCREW PFH 8x2 BLK

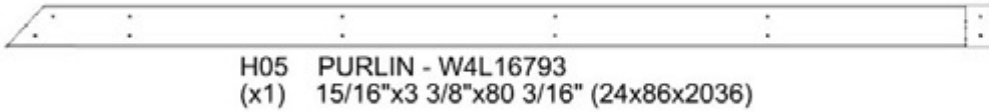
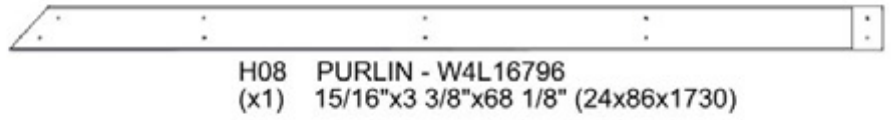
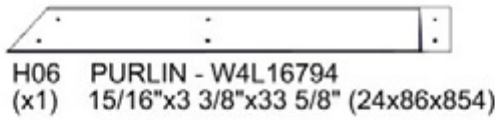

TIPS:

- ALIGN PURLIN PILOT HOLES WITH RAFTER PILOT HOLES.
- ATTACH SCREWS FROM THE CENTER AND WORK OUTWARDS.
- H03/H04 BOARDS DO NOT HAVE PILOT HOLES FOR OUTSIDE EDGE BOARDS.
- USING THE PURLINS AS A GUIDE AND A 1/8" DRILL BIT, DRILL PILOT HOLES INTO H03/H04 BOARDS.

IF PURLINS OVERHANG MORE THAN 5/8", CUT DOWN TO 5/8"

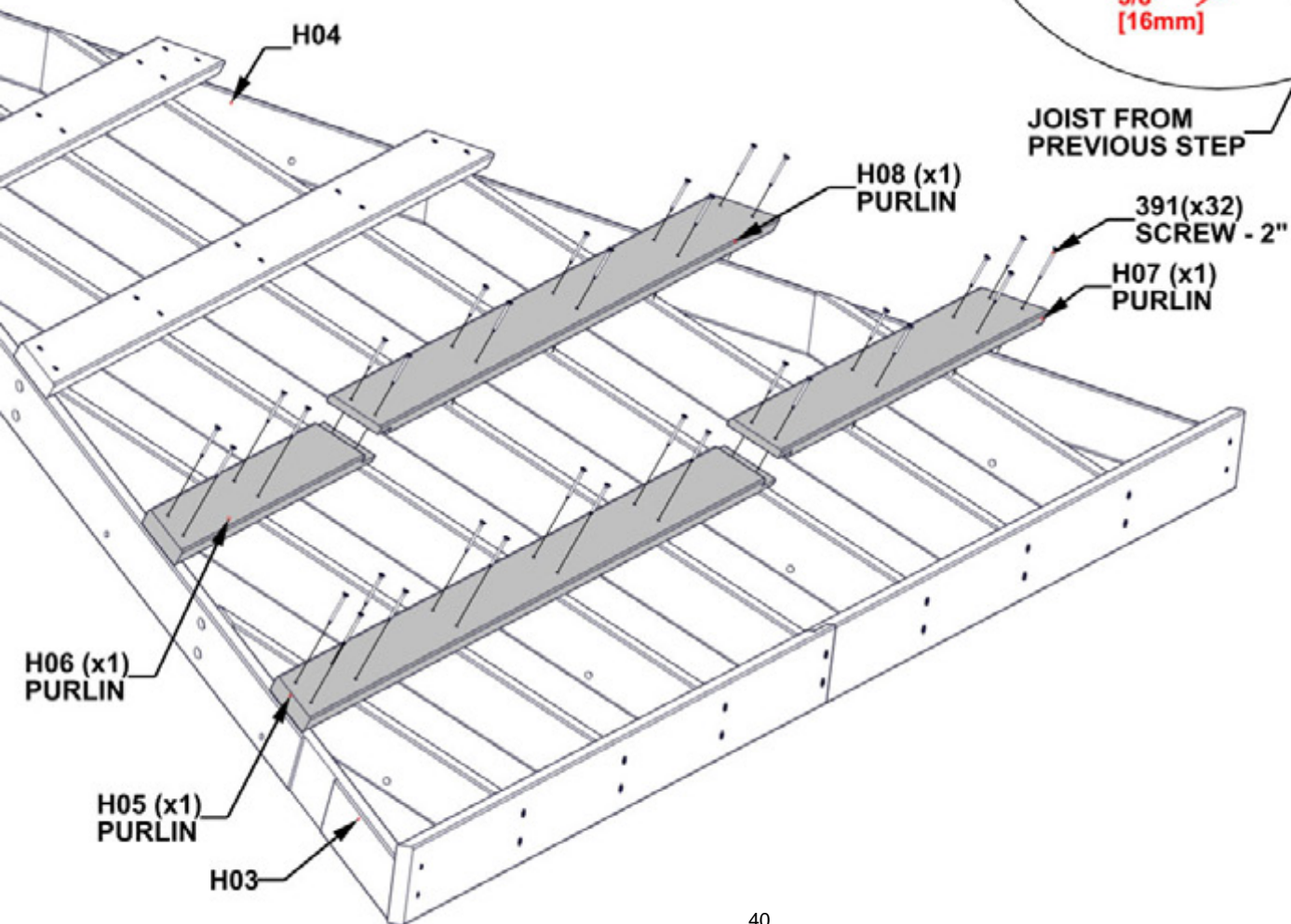
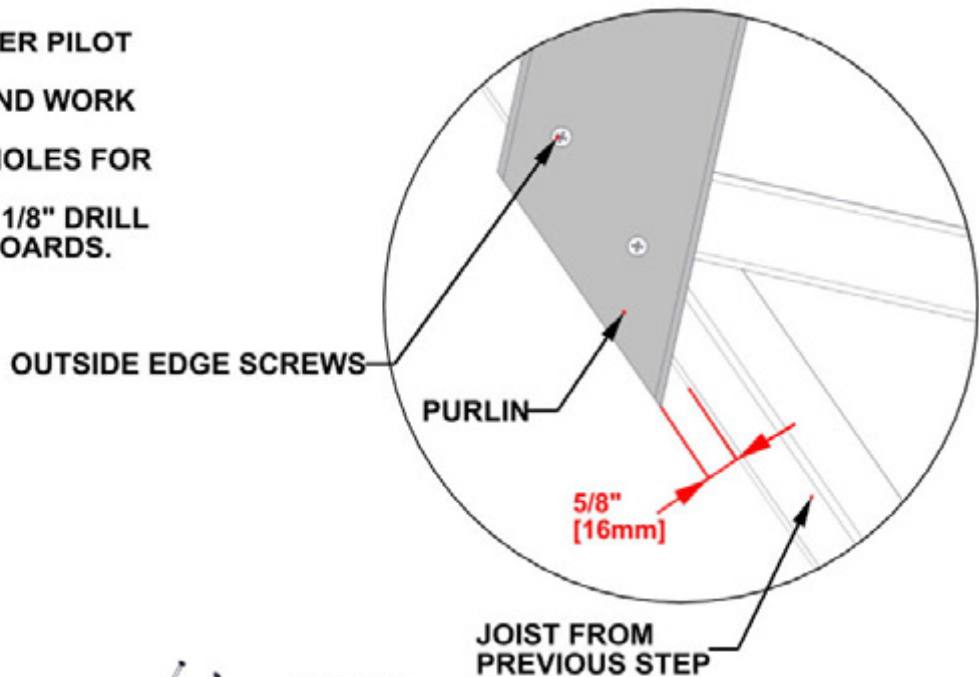

STEP 20 - 12FT ROOF PANEL ASSEMBLY

Qty	PART NUMBER	DESCRIPTION
16	H100833	SCREW WOODGRIP 10-16x3/4

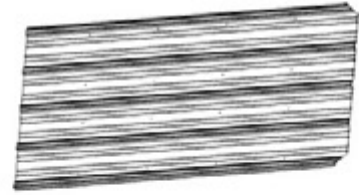
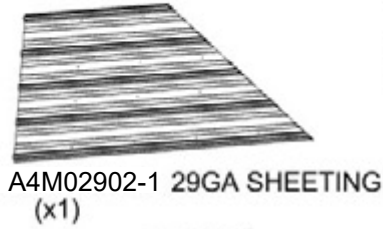

TIPS:

- REMOVE PROTECTIVE BLUE FILM
- STARTING IN THE CENTER, PLACE PANELS AS SHOWN BELOW.
- OVERLAP PANELS BY ONE RIDGE.
- PANELS SHOULD BE FLUSH WITH PURLIN ENDS AND Q01 ROOF JOIST.
- ONCE SHEETING IS IN PLACE, IT IS RECOMMENDED TO ADD H100833 SCREWS IN THE MIDDLE OF SHEETS TO HOLD SHEETING FOR THE NEXT STEP.

WARNING: GLOVES ARE RECOMMENDED WHEN HANDLING STEEL ROOF PIECES.

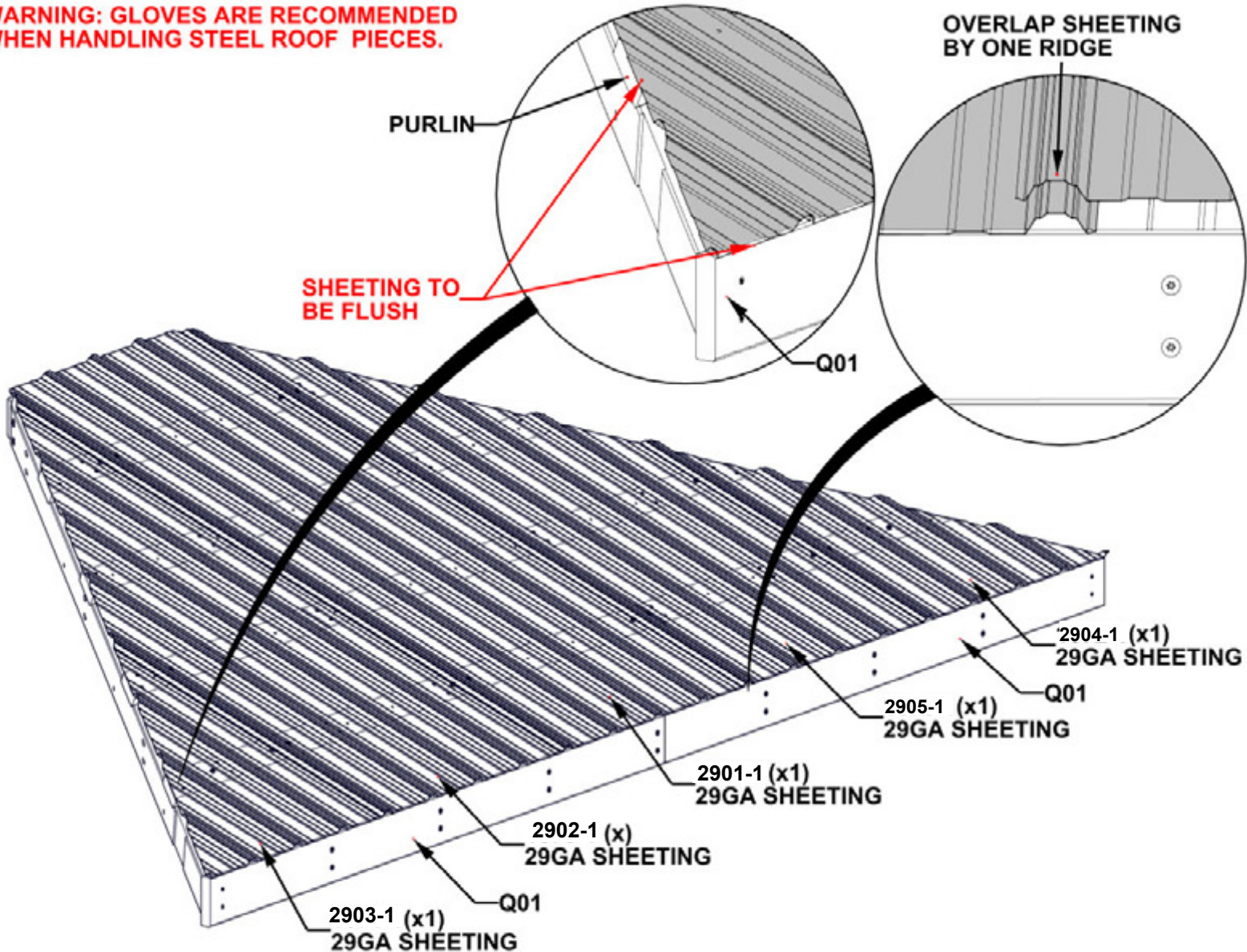

STEP 21 - 12FT ROOF PANEL ASSEMBLY

Qty	PART NUMBER	DESCRIPTION
8	H100833	SCREW WOODGRIP 10-16x3/4



A4M02906 RIDGE CAP CHANNEL
(x2)

TIPS:

- POSITION THE RIDGE CAP CHANNEL OVER THE EDGE OF THE ROOF PANELS WITH THE WIDER SIDE OF THE CHANNEL ON THE BOTTOM.
- MAKE SURE THE PANELS ARE FULLY SEATED INTO THE CHANNEL.
- FLUSH THE TOP OF THE CHANNEL WITH THE TOP OF THE METAL PANELS.

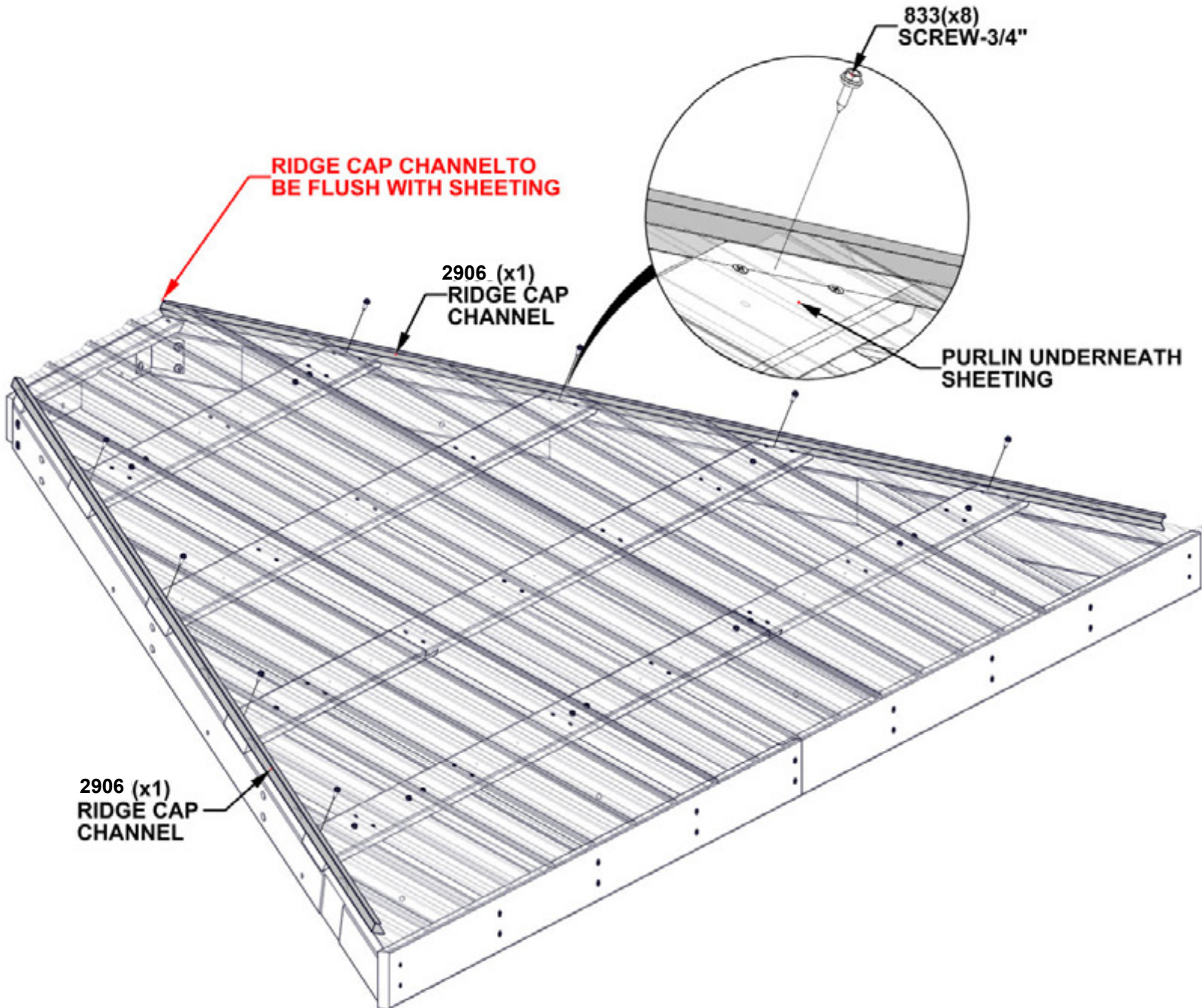

STEP 22 - 12FT ROOF PANEL ASSEMBLY

Qty	PART NUMBER	DESCRIPTION
30	H100833	SCREW WOODGRIP 10-16x3/4

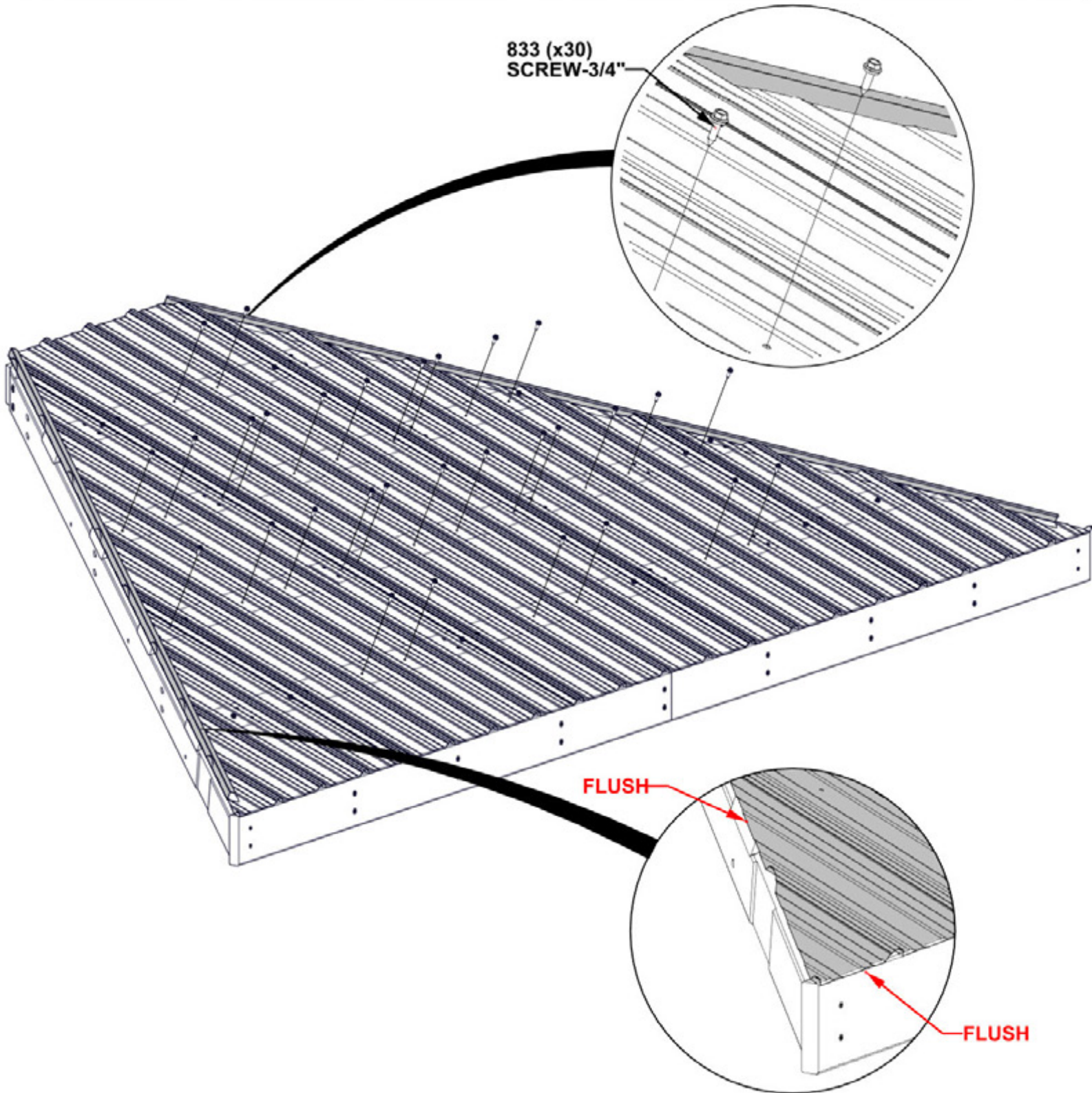

**REPEAT 12FT ROOF PANEL
ASSEMBLY STEPS 15 THROUGH 22**

STEP 23 - 10FT ROOF PANEL ASSEMBLY

Qty	PART NUMBER	DESCRIPTION
4	H100171	BOLT WH 1/4x1 BLK
4	H100398	TNUT-1/4" BLK



H11 ROOF JOIST - W4L16801
(x1) 15/16"x3 3/8"x12 15/16" (24x86x328)

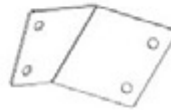

A4M01664 PANEL BRACKET
(x1)

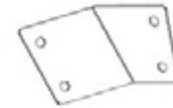

A4M01665 PANEL BRACKET
(x1)

**INSERT T-NUTS FIRST
HAND TIGHTEN ONLY**

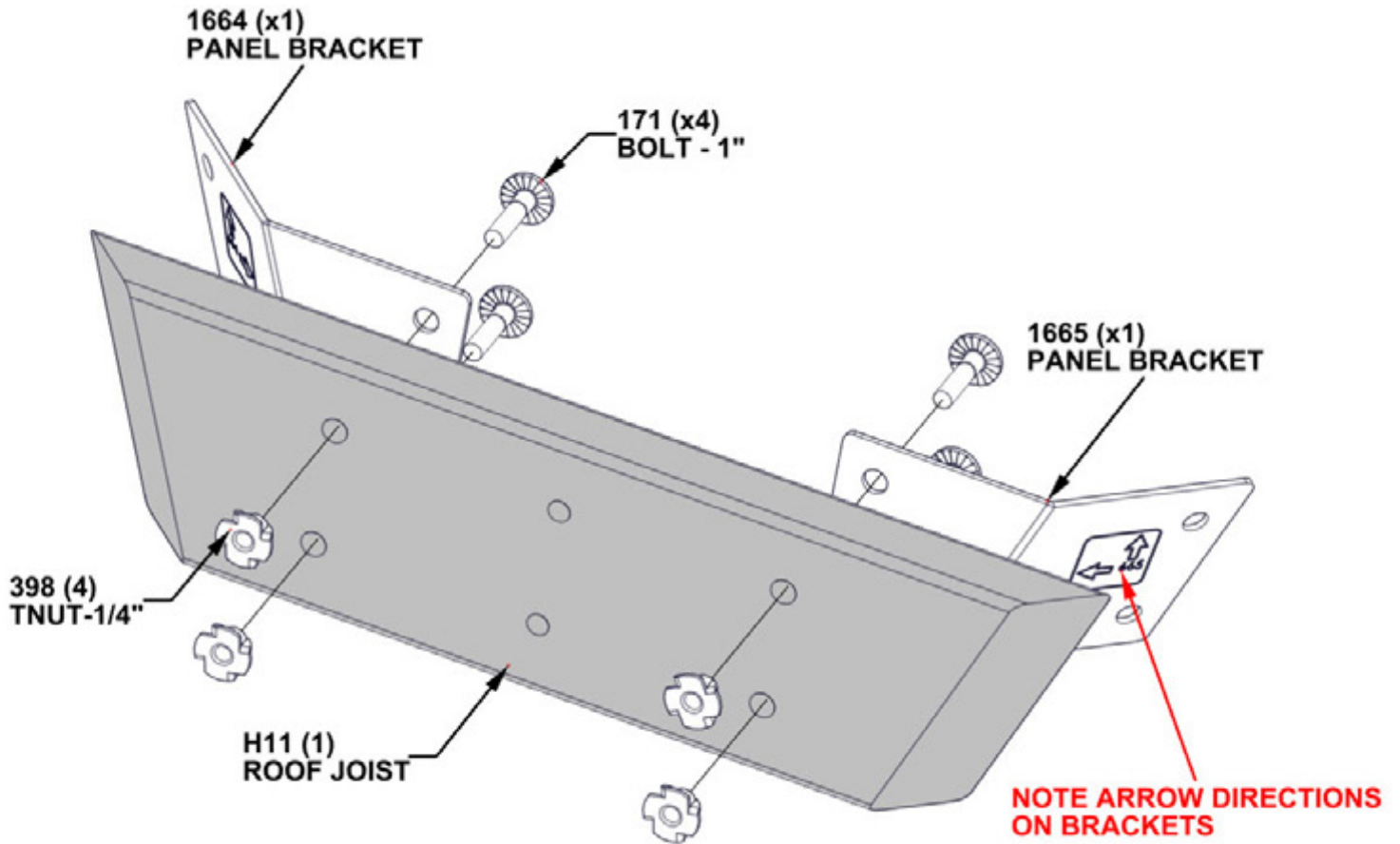

STEP 24 - 10FT ROOF PANEL ASSEMBLY

Qty	PART NUMBER	DESCRIPTION
4	H100171	BOLT WH 1/4x1 BLK
4	H100398	TNUT-1/4" BLK



H12 ROOF JOIST - W4L16802
(x1) 15/16"x3 3/8"x79 1/4" (24x86x2013)



H13 ROOF JOIST - W4L16803
(x1) 15/16"x3 3/8"x79 1/4" (24x86x2013)

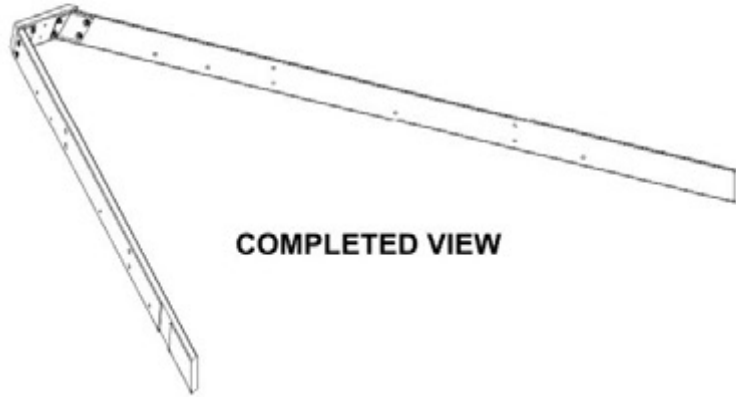

COMPLETED VIEW

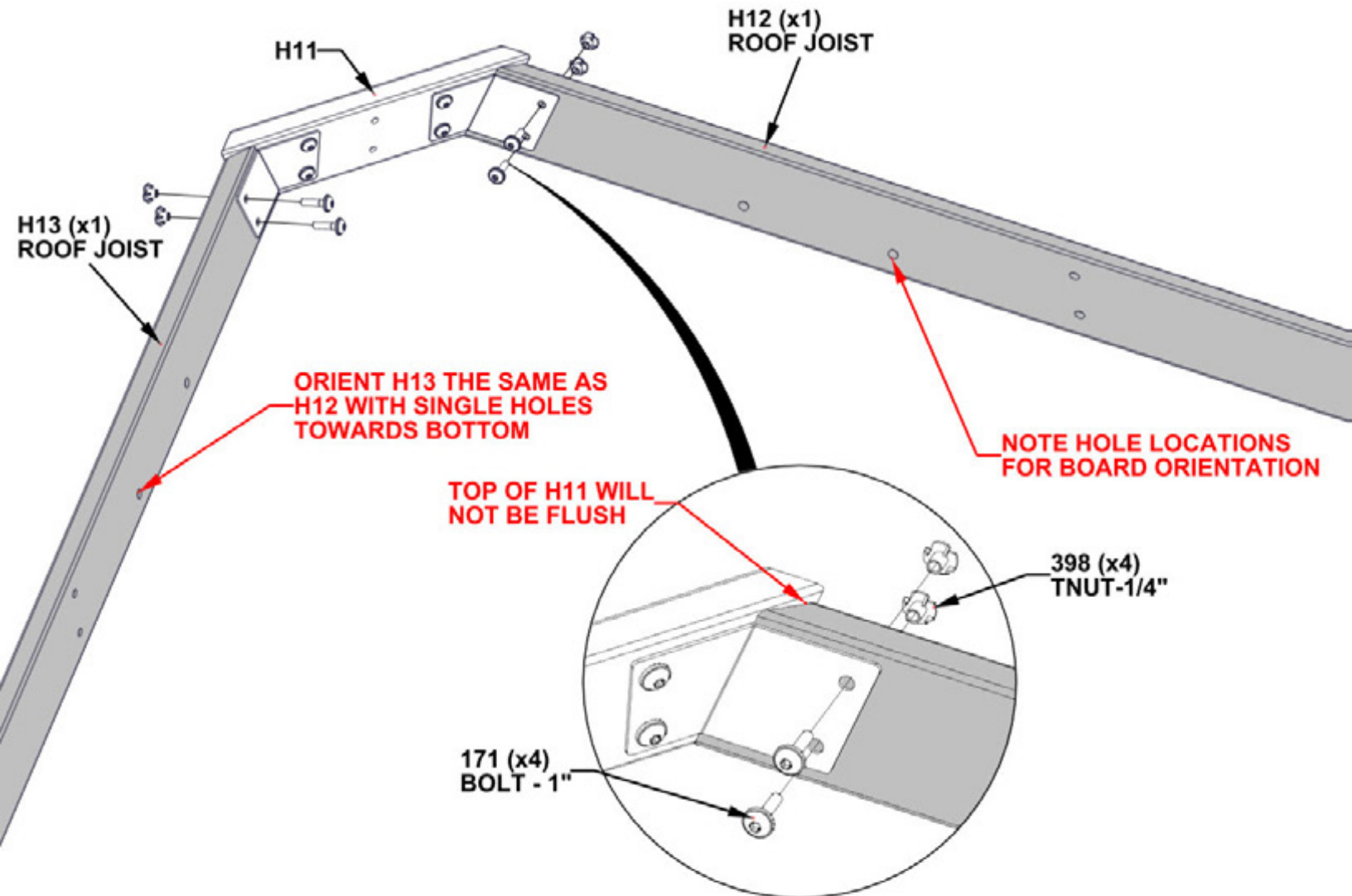

STEP 25 - 10FT ROOF PANEL ASSEMBLY



E11 RAFTER - W4L16807
(x1) 1 7/16"x3 3/8"x41 3/16" (36x86x1047)



E09 RAFTER - W4L16805
(x1) 1 7/16"x3 3/8"x41 3/16" (36x86x1047)



E08 RAFTER - W4L16804
(x1) 1 7/16"x3 3/8"x57 1/2" (36x86x1460)

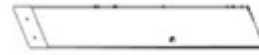

E12 RAFTER - W4L16808
(x1) 1 7/16"x3 3/8"x20 3/4" (36x86x527)



E10 RAFTER - W4L16806
(x1) 1 7/16"x3 3/8"x20 3/4" (36x86x527)

Qty	PART NUMBER	DESCRIPTION
10	H101030	SCREW CONFIRMAT 7x2 BLK

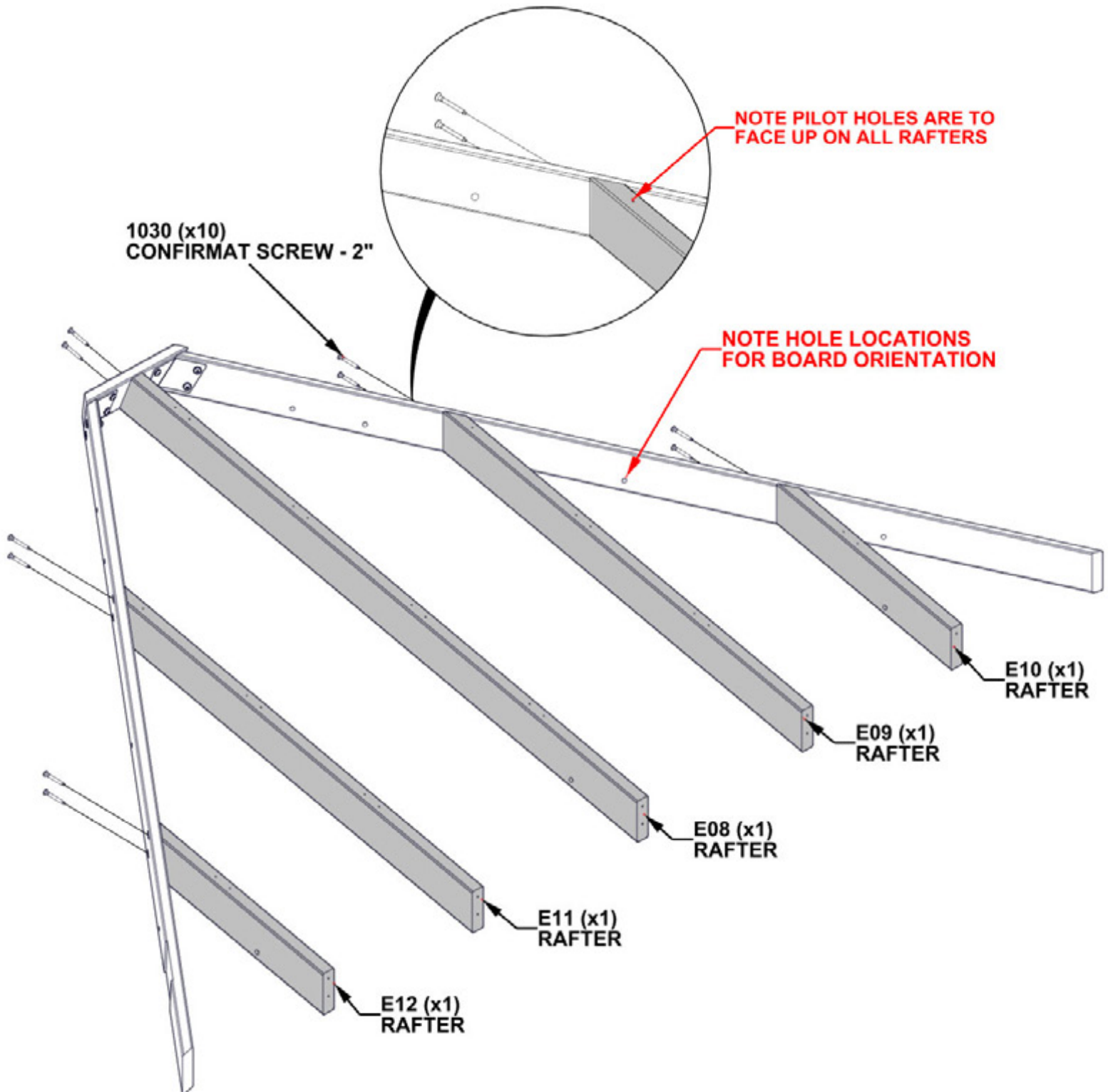

STEP 26A - 10FT ROOF PANEL ASSEMBLY

Qty	PART NUMBER	DESCRIPTION
4	H100382	SCREW PFH 8x1 3/4 BLK
10	H101030	SCREW CONFIRMAT 7x2 BLK



Q02 ROOF JOIST - W4L16800
(x2) 15/16"4 7/16" (24x112x1554)

TIP:
• RAFTERS MAY NEED TO BE LOOSENED TO ATTACH Q02 TO H13/H12

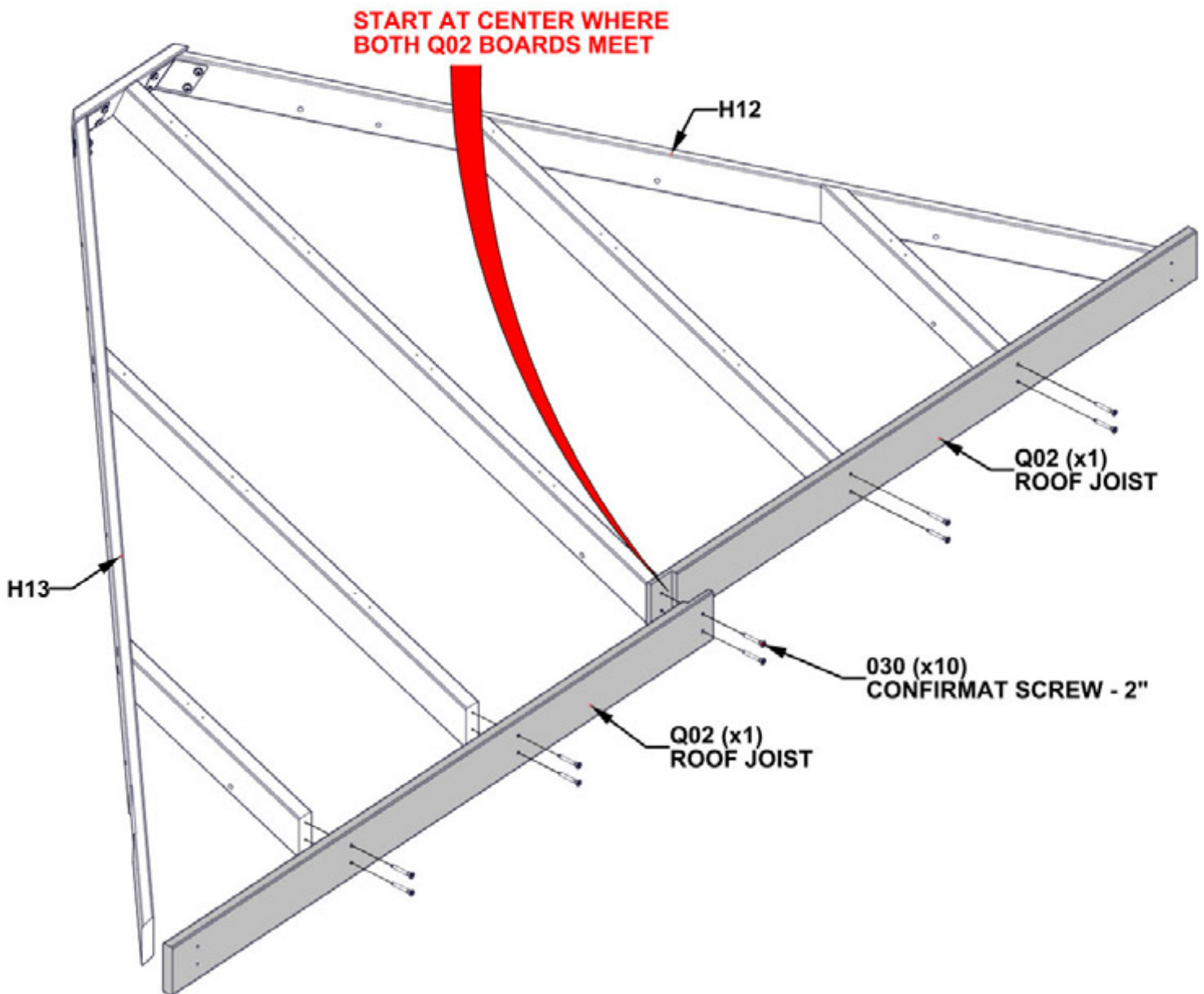

STEP 26B - 10FT ROOF PANEL ASSEMBLY

TIPS:

- USING THE Q02 BOARD AS A GUIDE AND A 1/8" DRILL BIT, DRILL PILOT HOLES INTO THE H13 BOARDS USING THE DIMENSION BELOW.
- REPEAT ON OPPOSITE END WITH H12 BOARD.

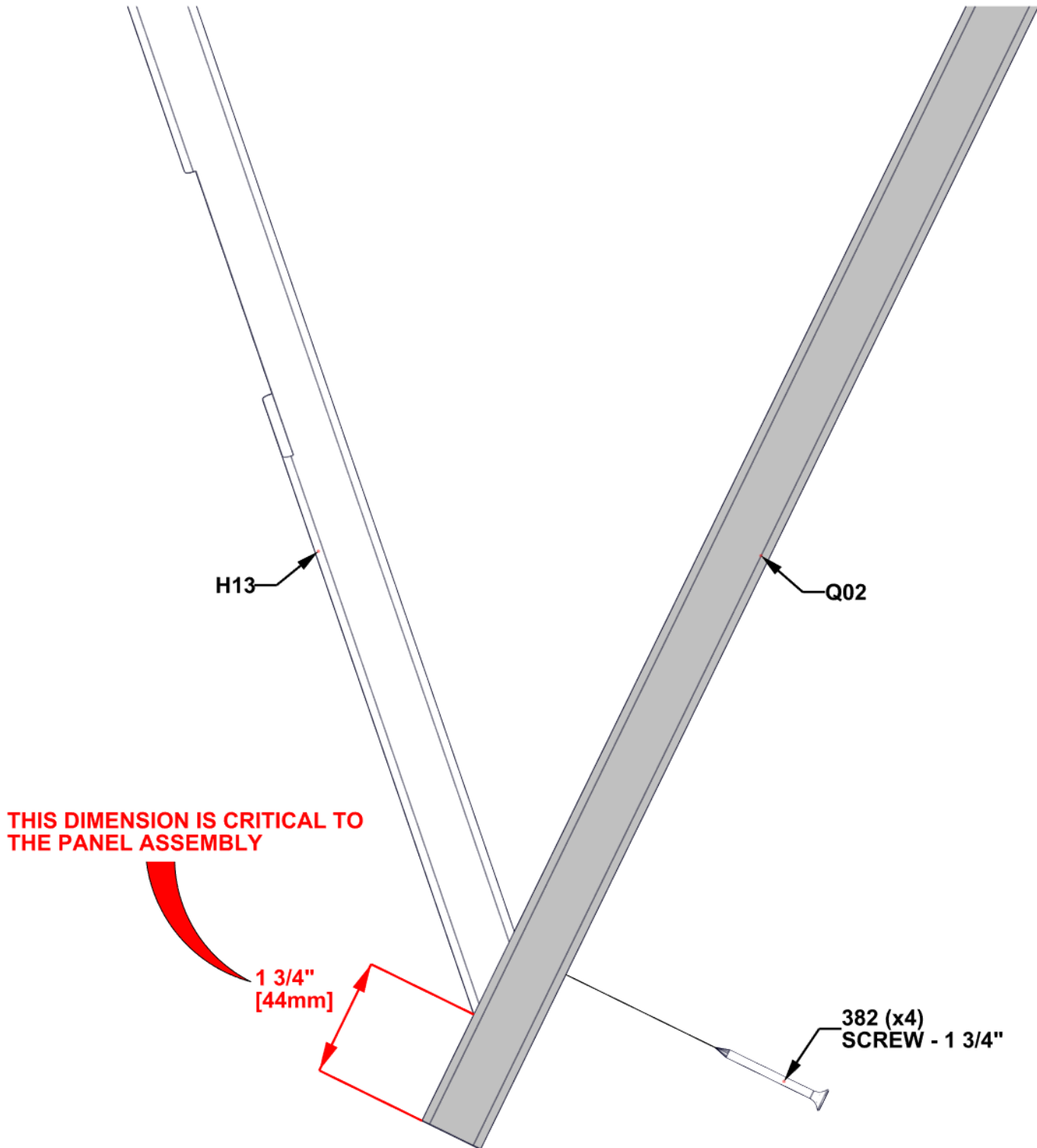

STEP 26C - 10FT ROOF PANEL ASSEMBLY

TIP:

- LOOSEN HARDWARE TO ADJUST FOR SQUARING IF NEEDED

CRITICAL:

- SQUARE UNIT BEFORE PROCEEDING TO NEXT STEPS.
- THE BELOW DIMENSIONS ARE CRITICAL TO THE FINAL ROOF ASSEMBLY.
- MEASUREMENTS SHOULD BE WITHIN $\pm 1/4"$
- MEASUREMENTS OUTSIDE OF TOLERANCE WILL LEAD TO THE INABILITY TO ASSEMBLE THE ROOF.

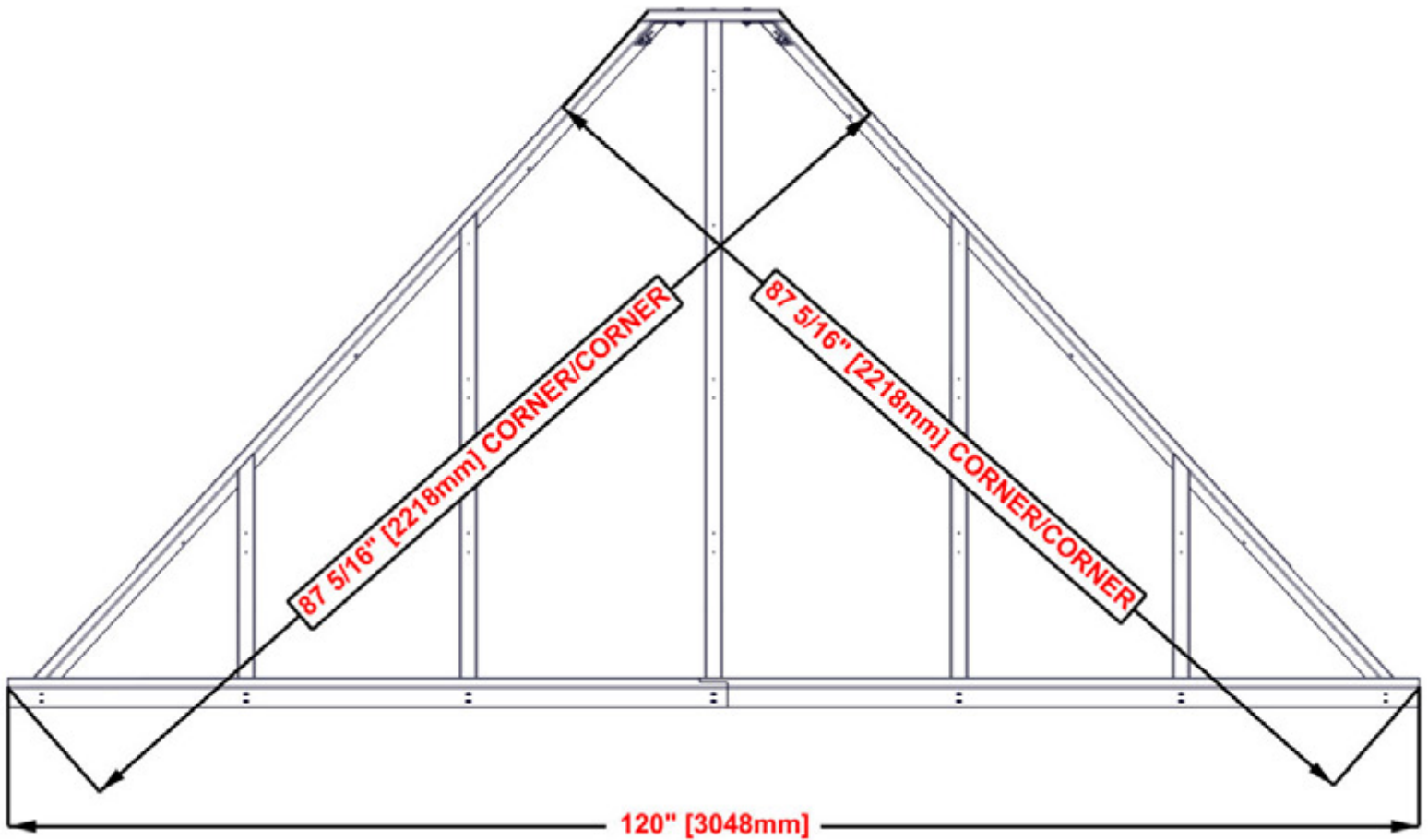

STEP 27 - 10FT ROOF PANEL ASSEMBLY

T02	PURLIN - W4L16813	(x1)	15/16"x1 5/16"x15" (24x34x382)
H17	PURLIN - W4L16812	(x1)	15/16"x3 3/8"x26 1/2" (24x86x673)
H15	PURLIN - W4L16810	(x1)	15/16"x3 3/8"x74 15/16" (24x86x1904)
H16	PURLIN - W4L16811	(x1)	15/16"x3 3/8"x50 11/16" (24x86x1288)

Qty	PART NUMBER	DESCRIPTION
40	H100391	SCREW PFH 8x2 BLK

H14	PURLIN - W4L16809	(x2)	15/16"x3 3/8"x50 13/16" (24x86x1290)
-----	-------------------	------	--------------------------------------

TIPS:

- ALIGN PURLIN PILOT HOLES WITH RAFTER PILOT HOLES.
- ATTACH SCREWS FROM THE CENTER AND WORK OUTWARDS.
- H12/H13 BOARDS DO NOT HAVE PILOT HOLES FOR OUTSIDE EDGE BOARDS.
- USING THE PURLINS AS A GUIDE AND A 1/8" DRILL BIT, DRILL PILOT HOLES INTO H12/H13 BOARDS.

IF PURLINS OVERHANG MORE THAN 5/8", CUT DOWN TO 5/8"

OUTSIDE EDGE SCREWS

NOTE T02 IS TO BE FLUSH & WILL NOT OVER HANG SIDES

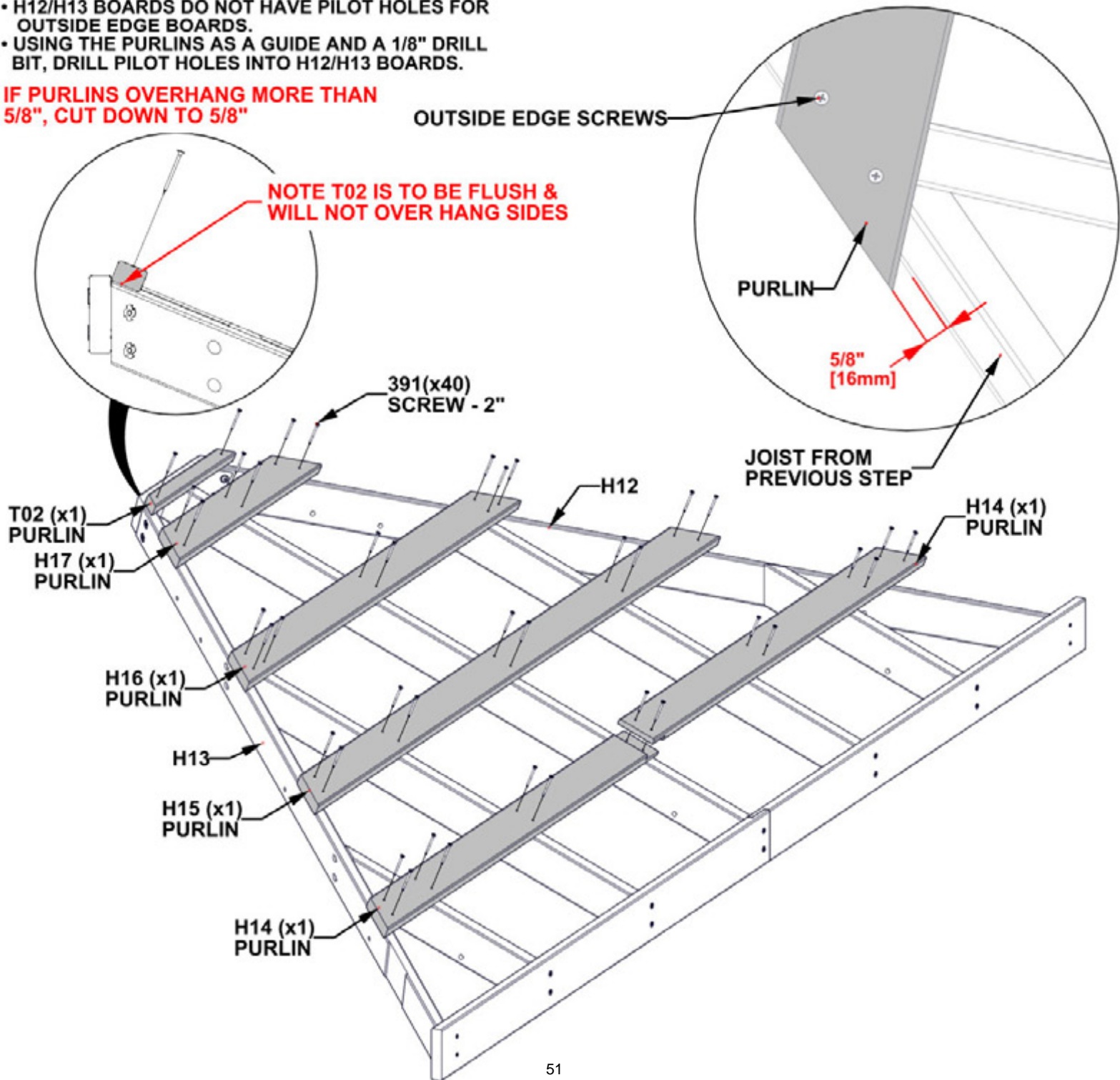

STEP 28 - 10FT ROOF PANEL ASSEMBLY

Qty	PART NUMBER	DESCRIPTION
12	H100833	SCREW WOODGRIP 10-16x3/4



A4M02902-2 29GA SHEETING (x1)

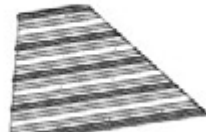

A4M02903-2 29GA SHEETING (x1)

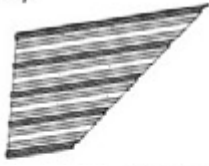

A4M02904-2 29GA SHEETING (x1)



A4M02905-2 29GA SHEETING (x1)



A4M02901-2 29GA SHEETING (x1)

TIPS:

- REMOVE PROTECTIVE BLUE FILM
- STARTING IN THE CENTER, PLACE PANELS AS SHOWN BELOW.
- OVERLAP PANELS BY ONE RIDGE.
- PANELS SHOULD BE FLUSH WITH PURLIN ENDS AND Q01 ROOF JOIST.
- ONCE SHEETING IS IN PLACE, IT IS RECOMMENDED TO ADD H100833 SCREWS IN THE MIDDLE OF SHEETS TO HOLD SHEETING FOR THE NEXT STEP.

WARNING: GLOVES ARE RECOMMENDED WHEN HANDLING STEEL ROOF PIECES.

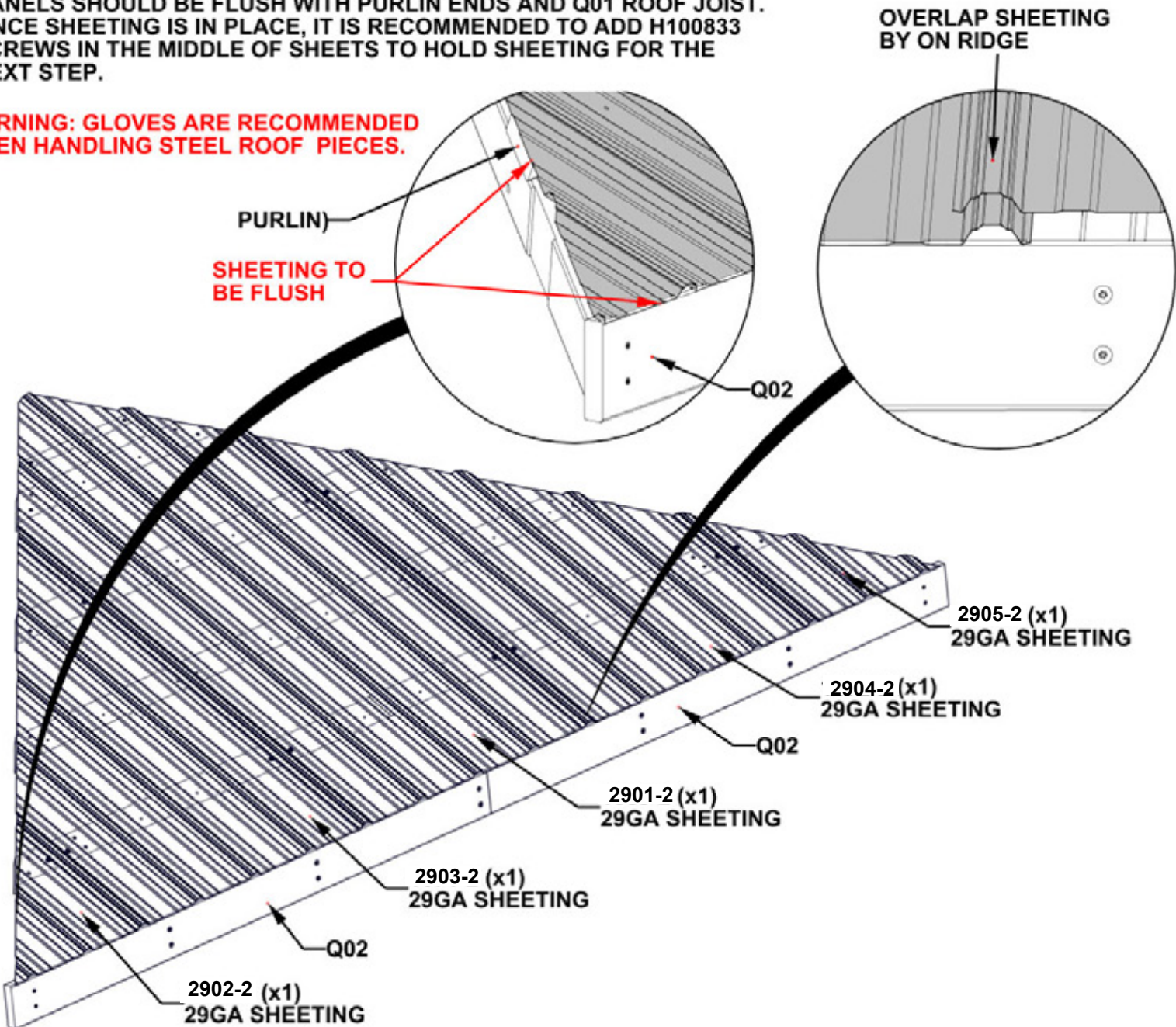

STEP 29 - 10FT ROOF PANEL ASSEMBLY

Qty	PART NUMBER	DESCRIPTION
8	H100833	SCREW WOODGRIP 10-16x3/4



A4M02906 RIDGE CAP CHANNEL
(x2)

TIPS:

- POSITION THE RIDGE CAP CHANNEL OVER THE EDGE OF THE ROOF PANELS WITH THE WIDER SIDE OF THE CHANNEL ON THE BOTTOM.
- MAKE SURE THE PANELS ARE FULLY SEATED INTO THE CHANNEL.
- FLUSH THE TOP OF THE CHANNEL WITH THE TOP OF THE METAL PANELS.

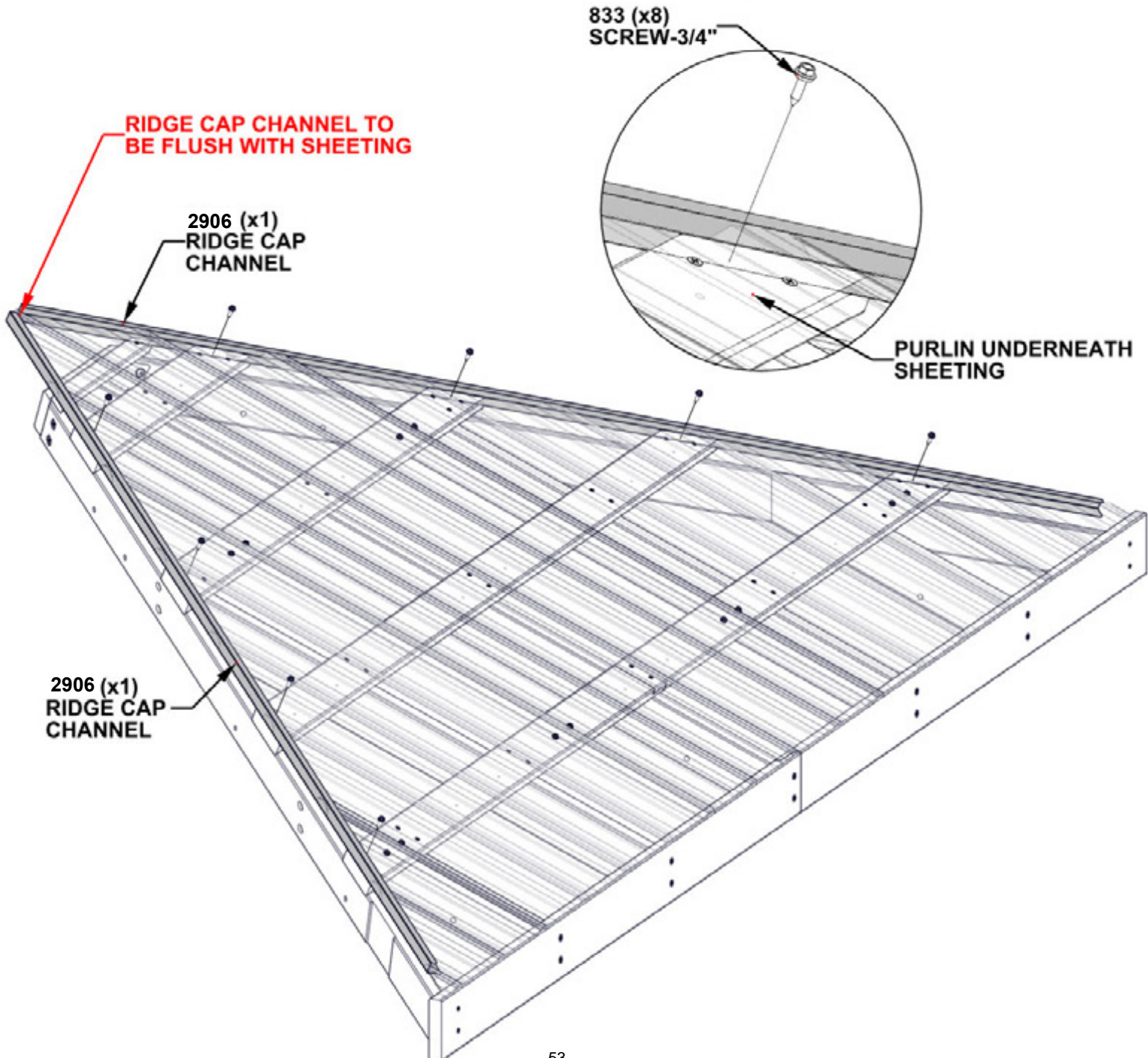

STEP 30 - 10FT ROOF PANEL ASSEMBLY

Qty	PART NUMBER	DESCRIPTION
20	H100833	SCREW WOODGRIP 10-16x3/4

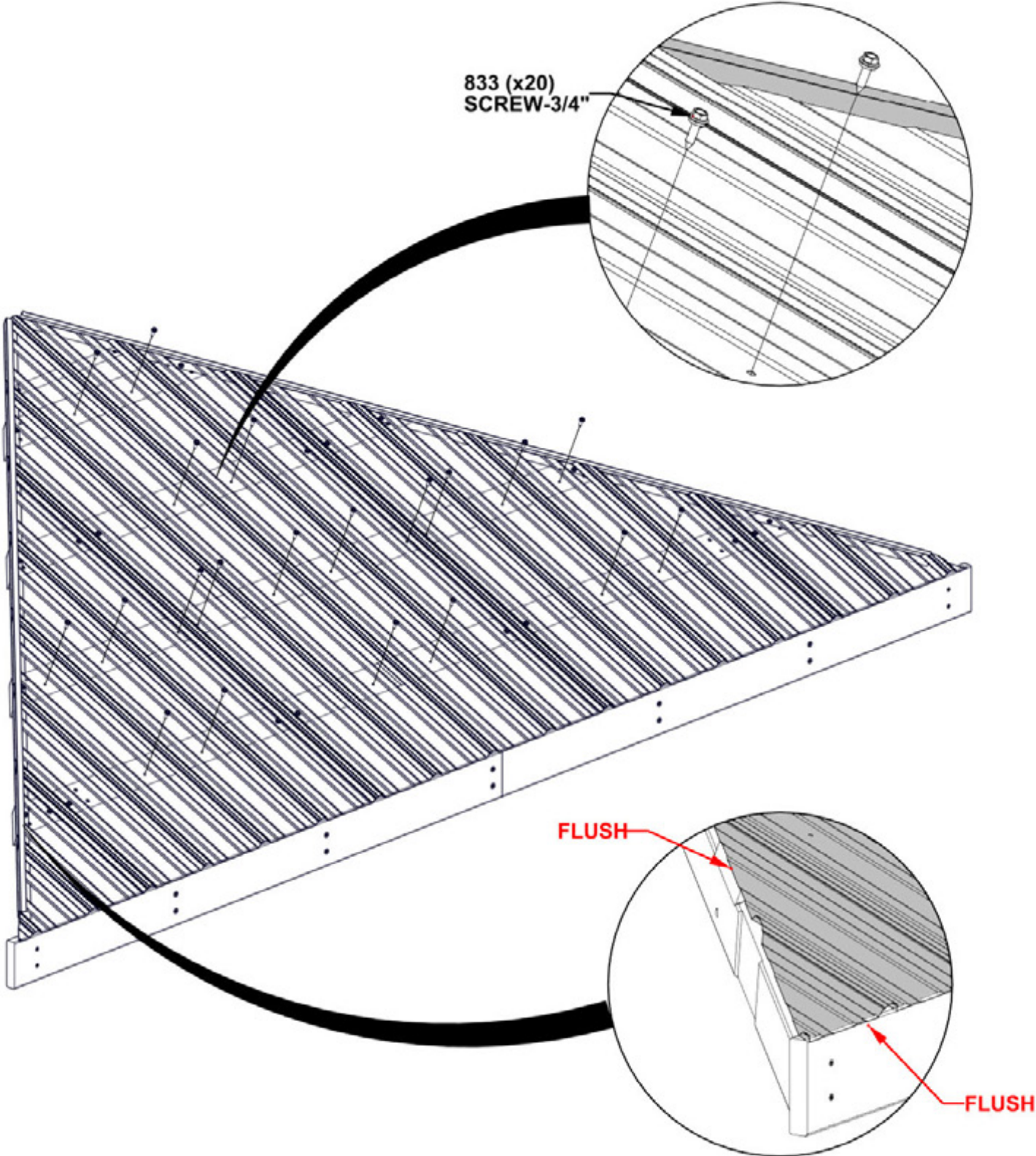

**REPEAT 10FT ROOF PANEL
ASSEMBLY STEPS 23 THROUGH 30**

STEP 31A - 10FT ROOF PANEL ATTACHMENT

TIPS:

- THREE PEOPLE ARE HELPFUL FOR THIS STEP.
- POSITION A PERSON ON A LADDER IN THE CENTER OF THE GAZEBO TO HELP SUPPORT THE ROOF PANEL.
- WITH TWO PEOPLE, WORK THE PANEL UP WITHOUT SLIDING OR DRAGGING, UNTIL IT MEETS THE ROOF SUPPORT FRAME.
- MAKE SURE THE ROOF PANEL SLIDES UNDERNEATH THE RIDGE CAP.

WARNING: GLOVES ARE RECOMMENDED WHEN HANDLING STEEL ROOF PIECES.

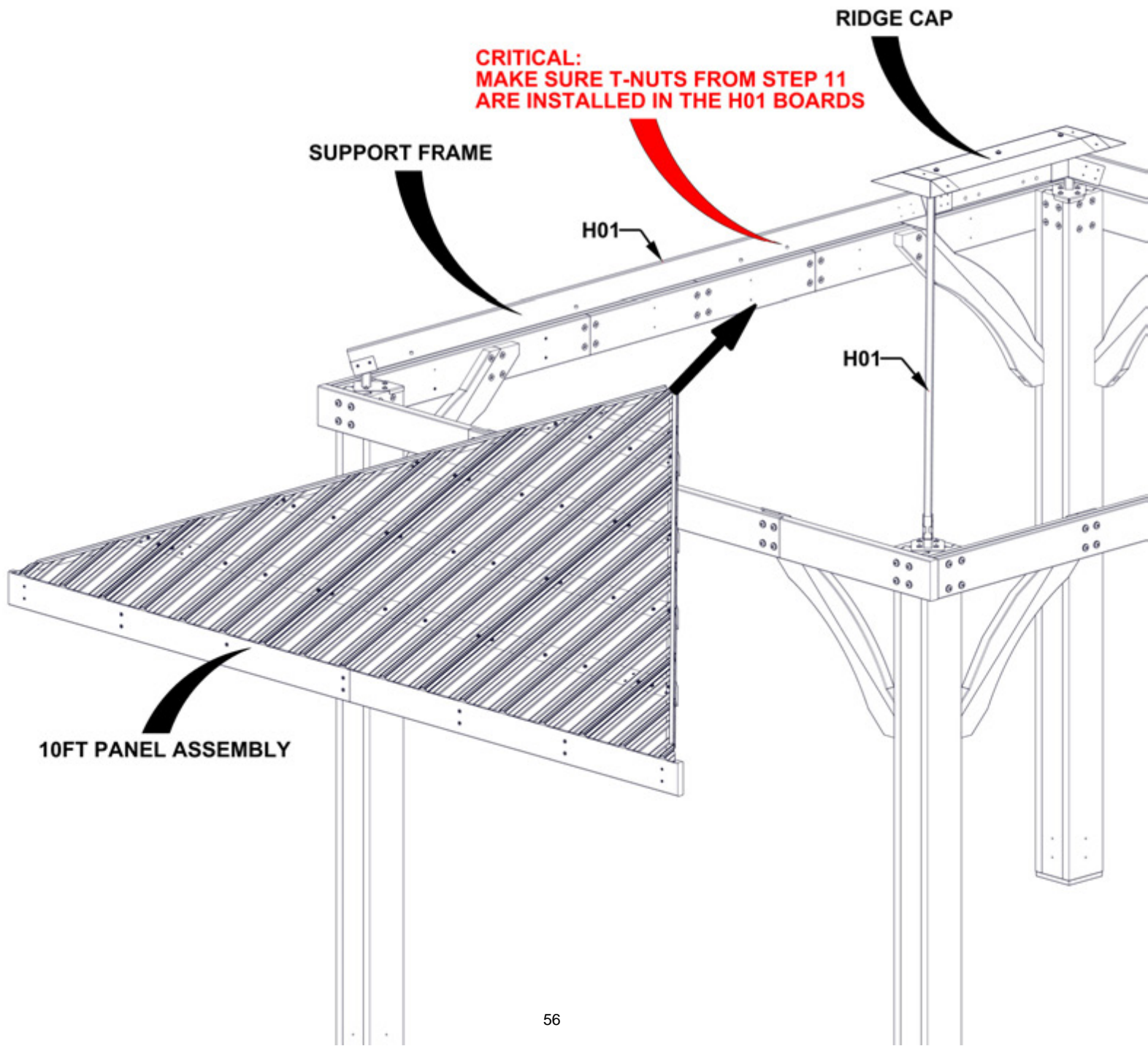

STEP 31B - 10FT ROOF PANEL ATTACHMENT

Qty	PART NUMBER	DESCRIPTION
2	H100198	WASHER LOCK EXT 8X19 BLK
2	H100378	BOLT WH 5/16x1 3/4 BLK

TIPS:

- IF NECESSARY, USE A LONG SCREWDRIVER OR CLAMPS TO HOLD PANELS IN PLACE.
- INSERT BOLTS INTO THE FIRST HOLE FROM THE TOP OF THE H12/H13 BOARDS.

HAND TIGHTEN ONLY

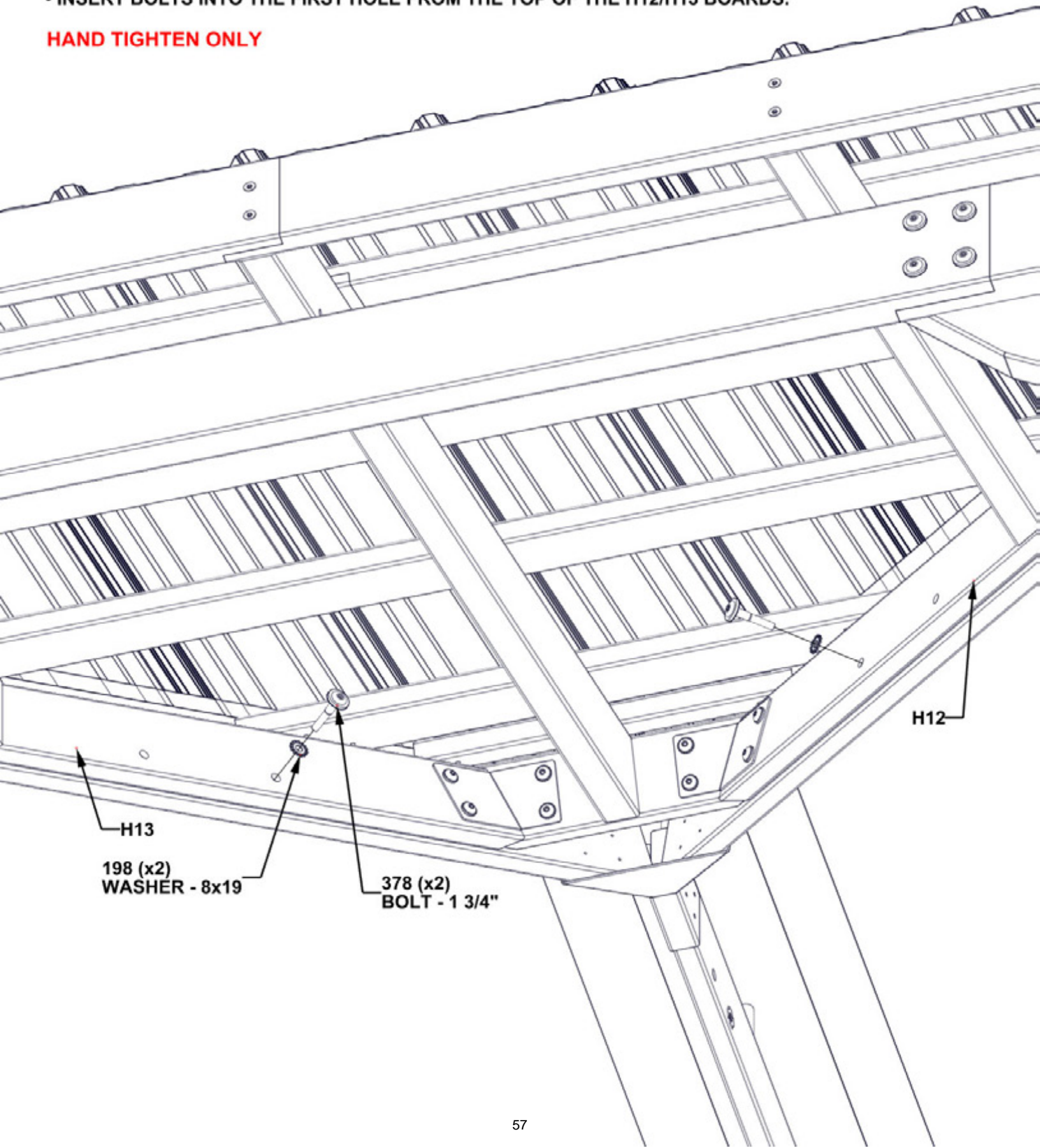

**REPEAT 10FT ROOF PANEL INSTALLATION
STEPS 31A & 31B**

STEP 32A - 12FT ROOF PANEL ATTACHMENT

TIPS:

- THREE PEOPLE ARE HELPFUL FOR THIS STEP.
- POSITION A PERSON ON A LADDER IN THE CENTER OF THE GAZEBO TO HELP SUPPORT THE ROOF PANEL.
- WITH TWO PEOPLE, WORK THE PANEL UP WITHOUT SLIDING OR DRAGGING, UNTIL IT MEETS THE ROOF SUPPORT FRAME.
- MAKE SURE THE ROOF PANEL SLIDES UNDERNEATH THE RIDGE CAP.

WARNING: GLOVES ARE RECOMMENDED WHEN HANDLING STEEL ROOF PIECES.

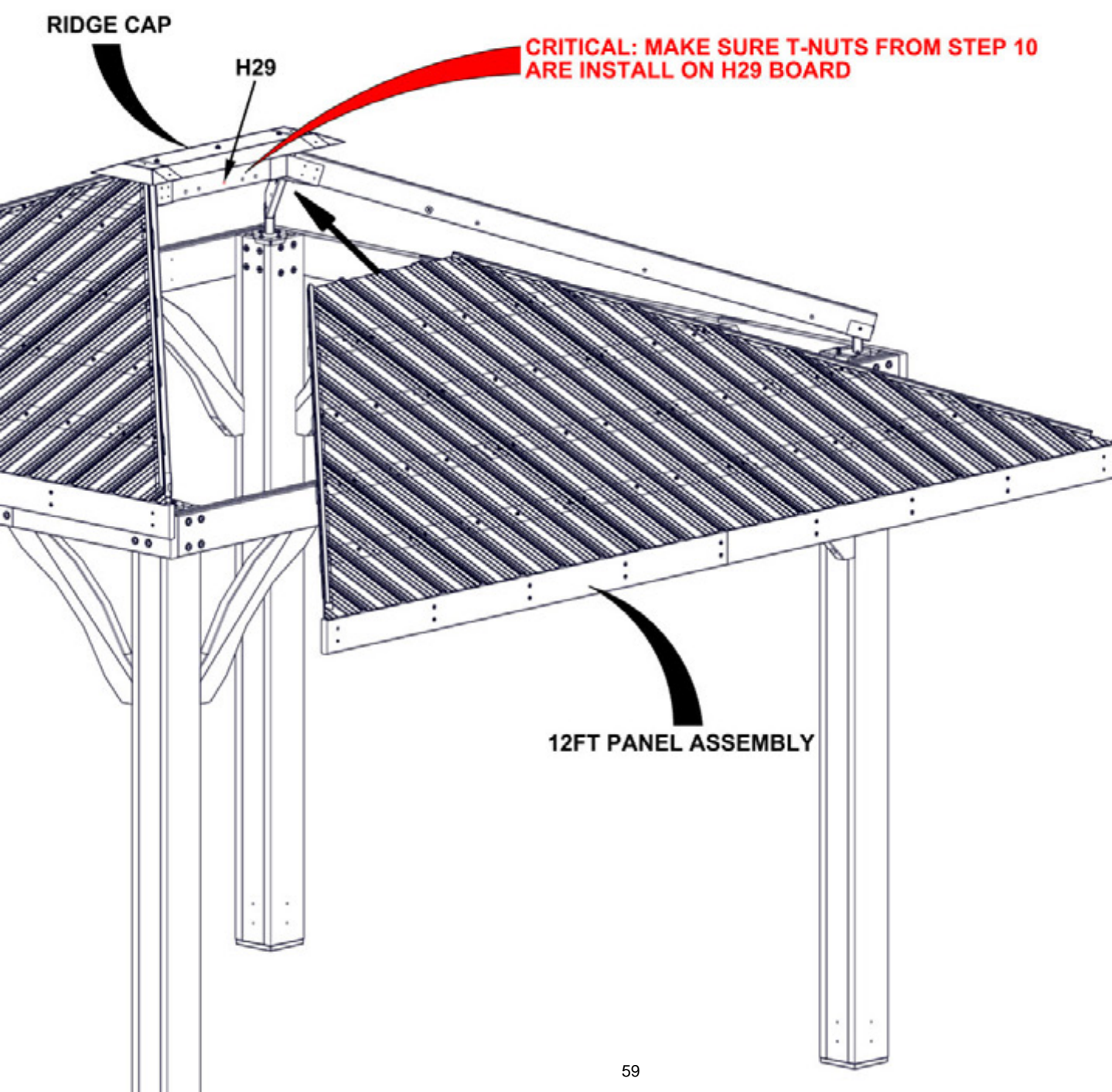

STEP 32B - 12FT ROOF PANEL ATTACHMENT

Qty	PART NUMBER	DESCRIPTION
2	H100198	WASHER LOCK EXT 8X19 BLK
2	H100378	BOLT WH 5/16x1 3/4 BLK

- TIP:**
• IF NECESSARY, USE A LONG SCREWDRIVER OR CLAMPS TO HOLD PANEL IN PLACE.

HAND TIGHTEN ONLY

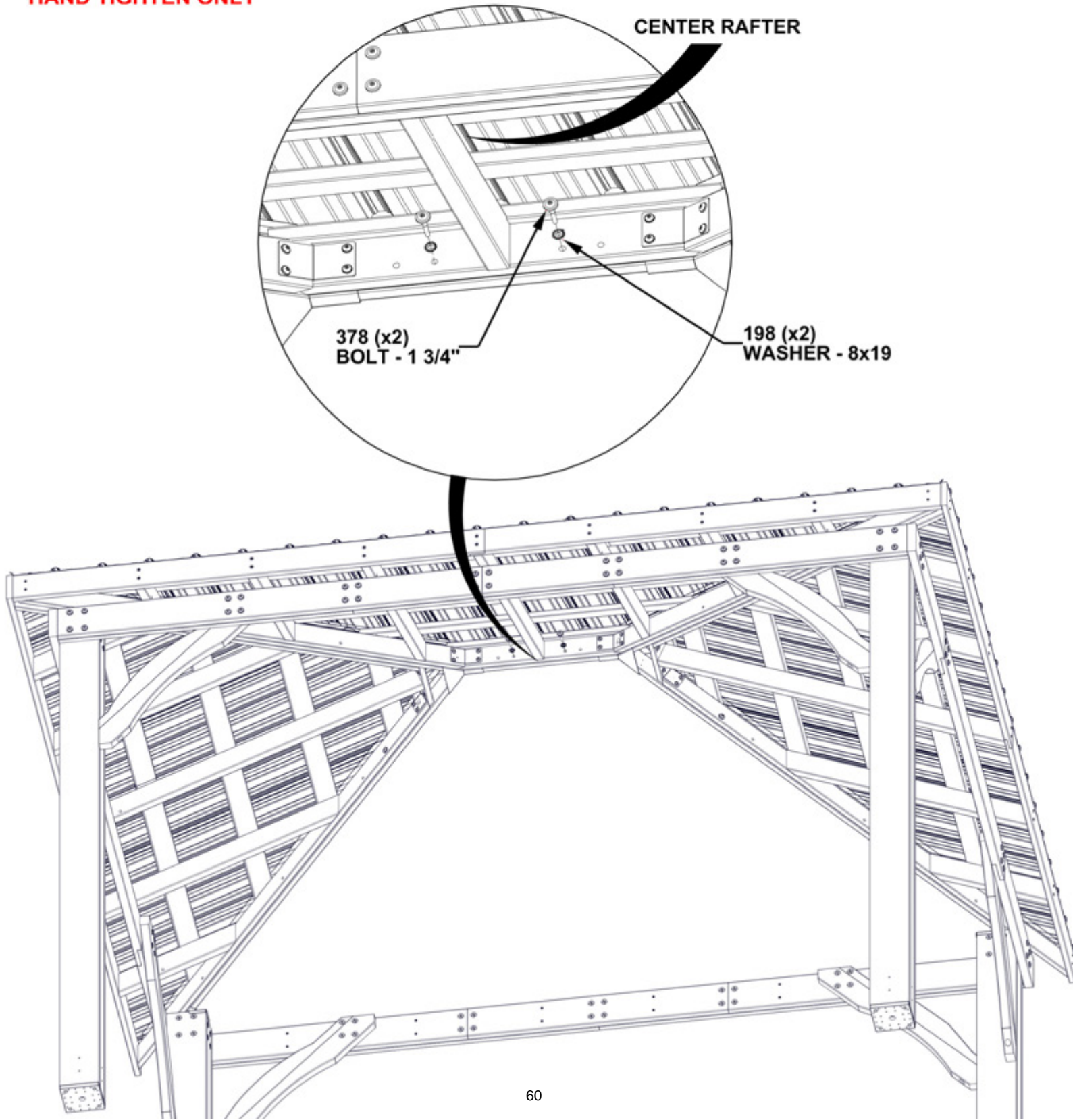

STEP 33A - 12FT ROOF PANEL ATTACHMENT

Qty	PART NUMBER	DESCRIPTION
2	H100198	WASHER LOCK EXT 8X19 BLK
2	H100415	BOLT WH 5/16x3 3/4 BLK
2	H100479	NUT LOCK 5/16 BLK
2	H100770	WASHER FLAT 5/16 BLK

- TIPS:**
- REPEAT STEP 32A FOR SECOND 12FT PANEL.
 - IF NECESSARY USE A LONG SCREWDRIVER OR CLAMPS TO HOLD PANEL IN PLACE.

HAND TIGHTEN ONLY

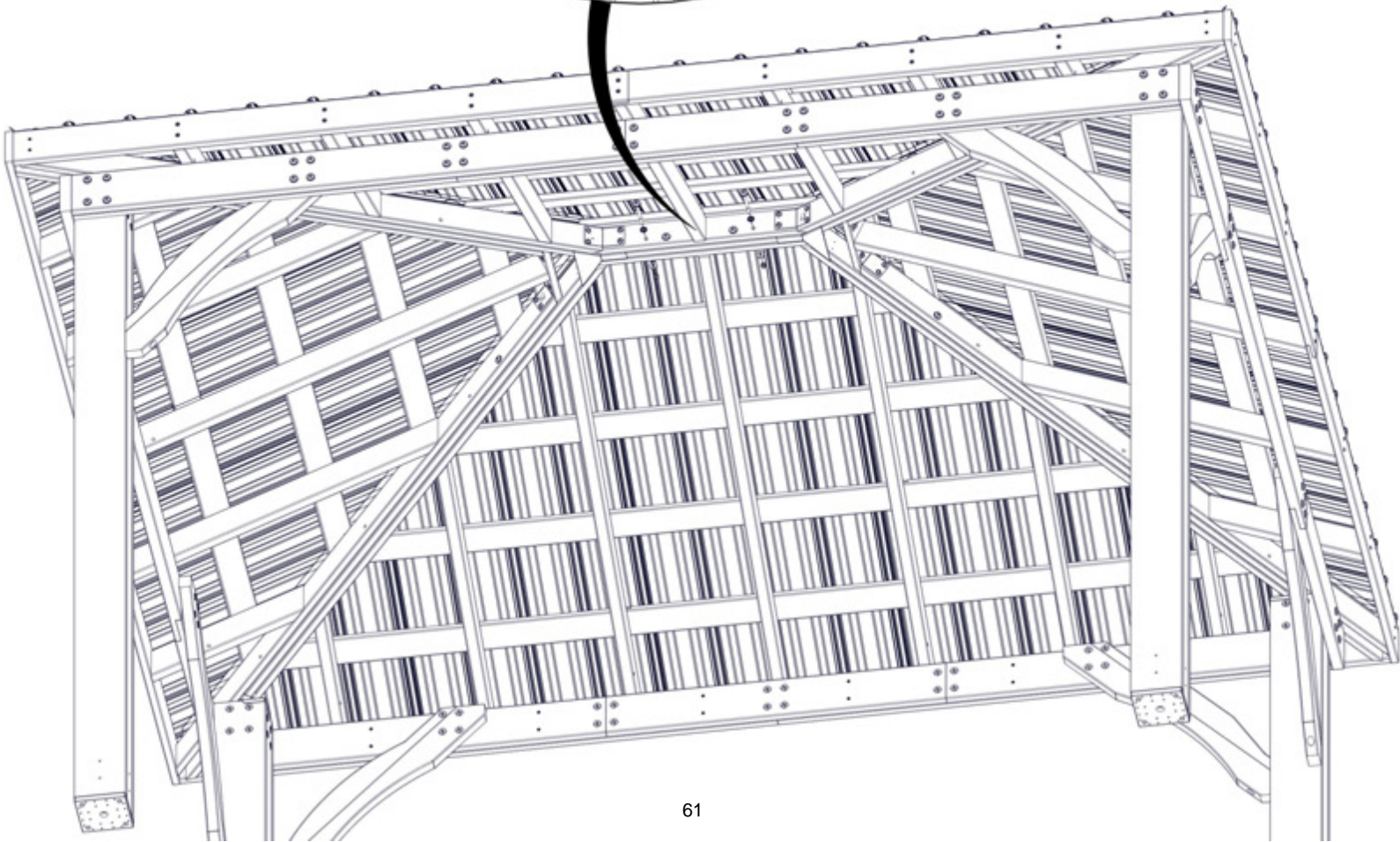
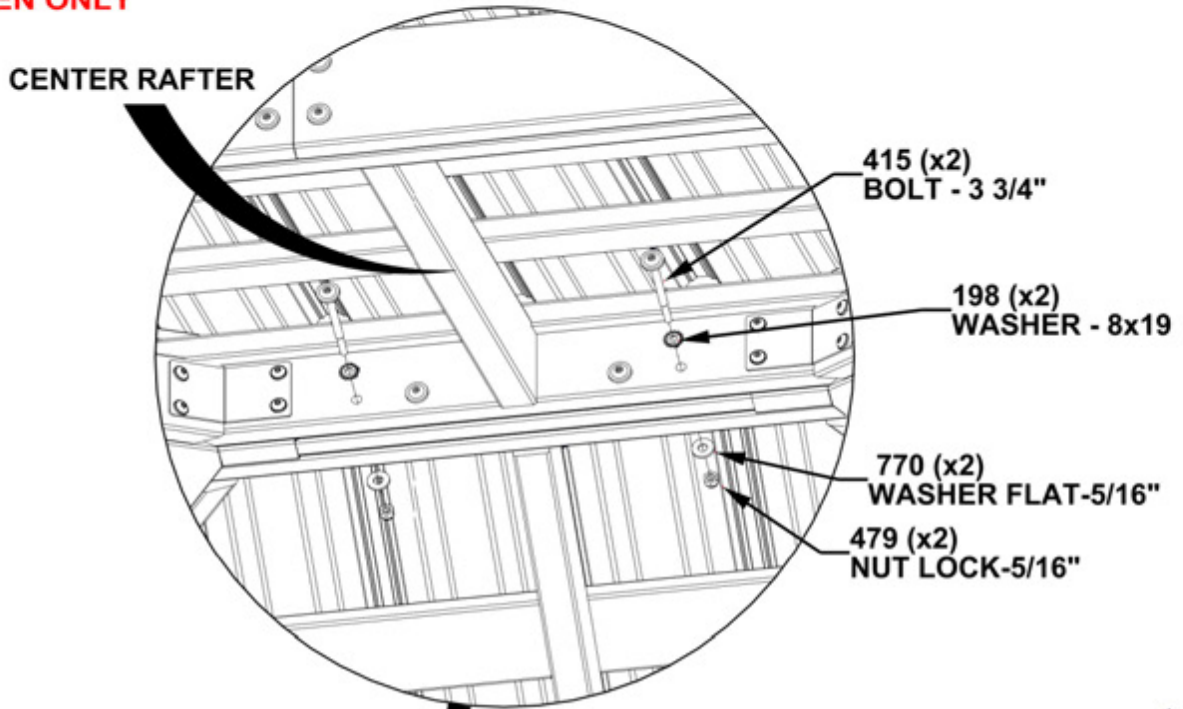

STEP 33B - 12FT ROOF PANEL ATTACHMENT

Qty	PART NUMBER	DESCRIPTION
12	H100198	WASHER LOCK EXT 8X19 BLK
12	H100415	BOLT WH 5/16x3 3/4 BLK
12	H100479	NUT LOCK 5/16 BLK
12	H100770	WASHER FLAT 5/16 BLK

HAND TIGHTEN ONLY

IF HOLES ARE SLIGHTLY UNALIGNED, DRIVE THE BOLT THROUGH THE (3) BOARDS USING A DRILL. THIS WILL ENABLE THE BOLTS TO SCREW INTO THE HOLES.

479 (x3)
NUT LOCK - 5/16"
770 (x3)
WASHER FLAT - 5/16"

198 (x3)
WASHER - 8x19

415 (x3)
BOLT - 3 3/4"

REPEAT ON ALL FOUR
DIAGONAL ROOF JOIST

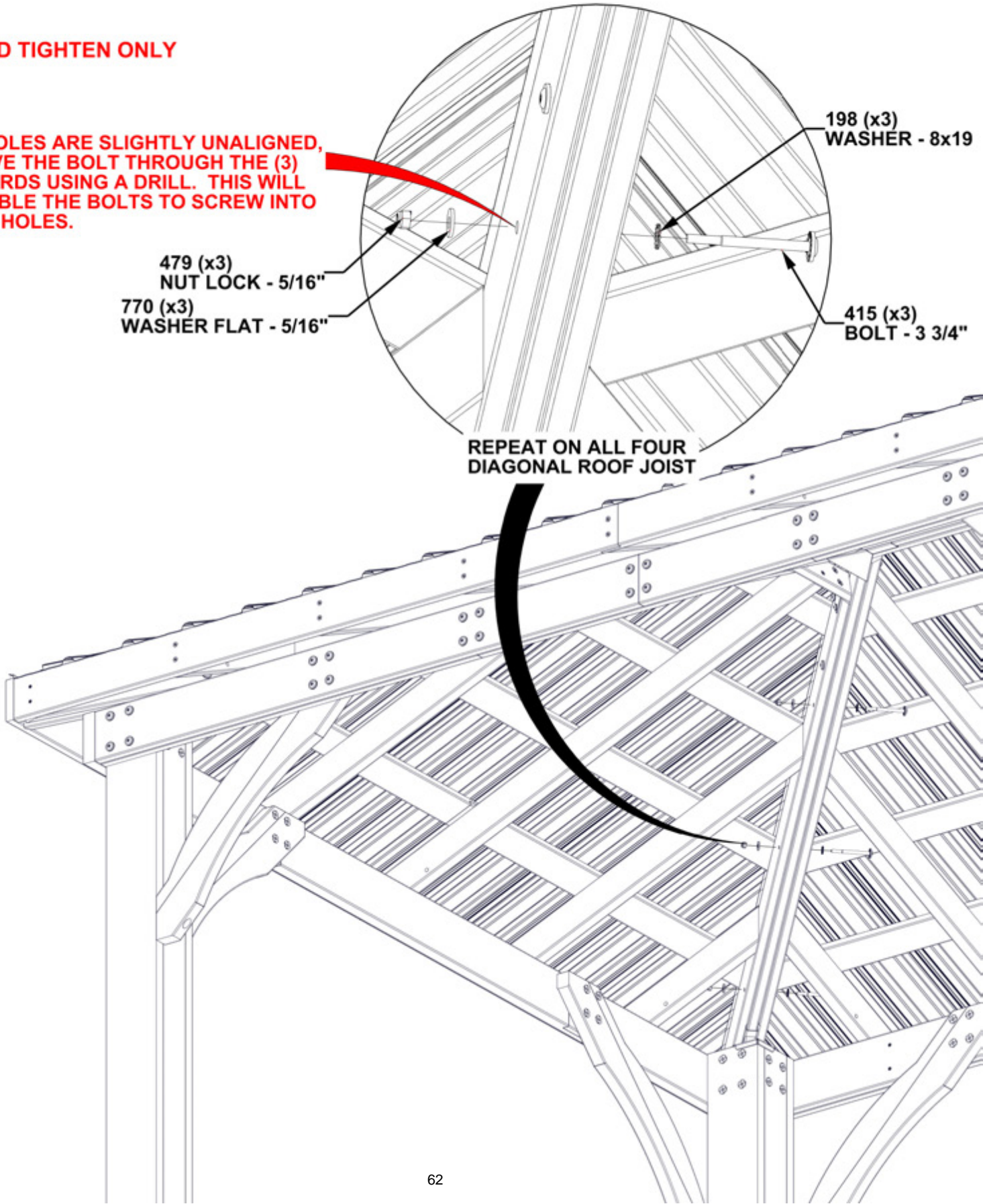

STEP 34 - ROOF PANEL ATTACHMENT

**TIGHTEN ALL THE HARDWARE IN THE ORDER SHOWN BELOW.
START AT THE TOP AND WORK YOUR WAY DOWN.**

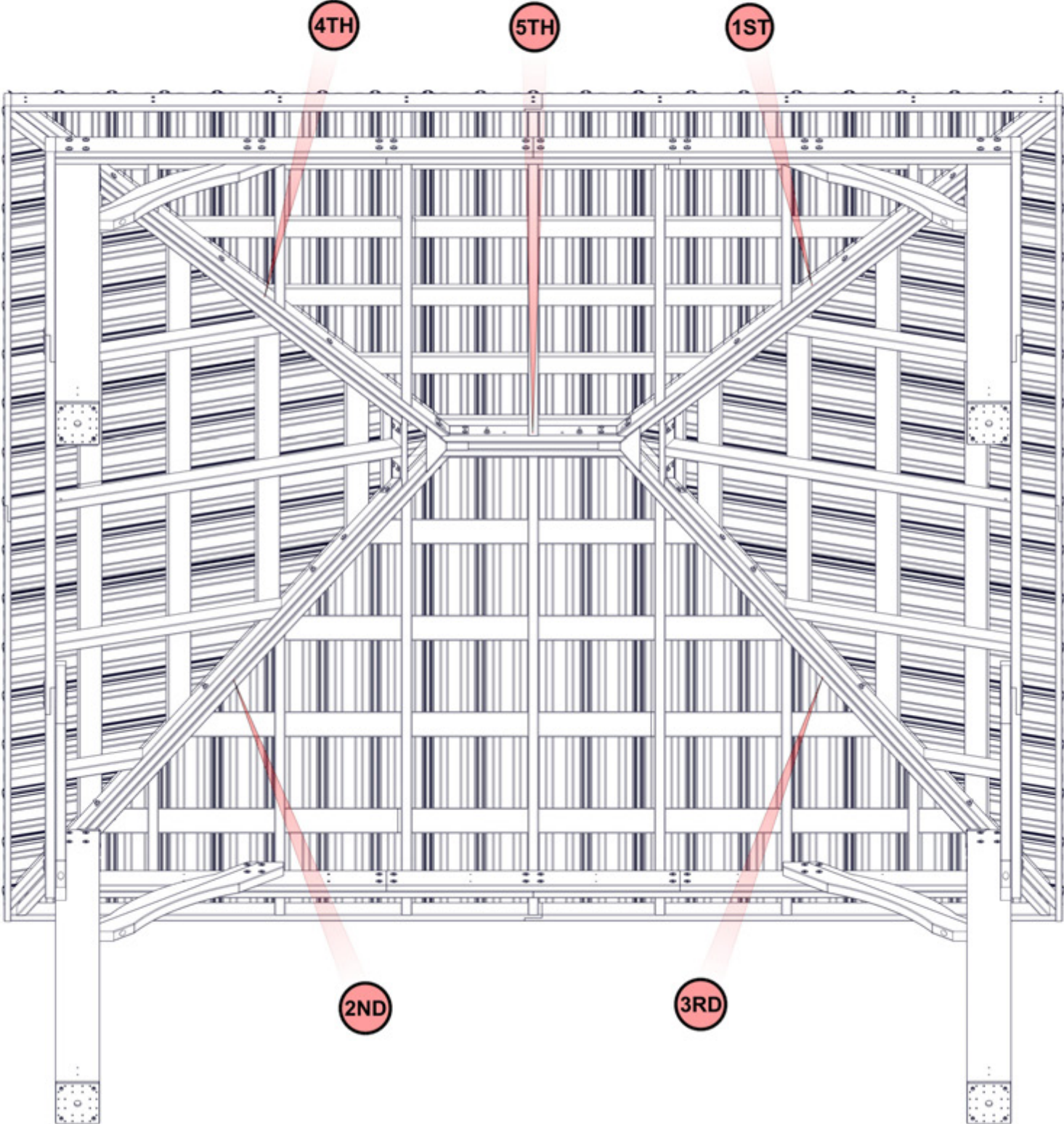

STEP 35 - ROOF ASSEMBLY

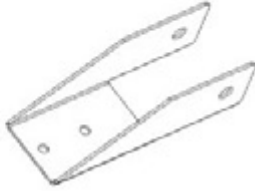

A4M01228 RAFTER CLIP
(x18)

Qty	PART NUMBER	DESCRIPTION
18	H100488	BOLT WH 1/4x2 BLK
36	H100536	SCREW PWH 8x1 1/4 BLK
18	H100630	WASHER FLAT 8x19 BLK
18	H100653	NUT LOCK 1/4 BLK

- TIPS:**
- ATTACH RAFTER CLIPS FIRST WITH 2" BOLTS.
 - USING THE BRACKET AS A TEMPLATE AND A 1/8" DRILL BIT, DRILL PILOT HOLES FOR THE H100536 SCREWS.
 - DRILL PILOT HOLES APPROXIMATELY 1/2" DEEP.
 - NOTE THERE ARE NO RAFTER CLIPS WHERE CORBLES ARE LOCATED.

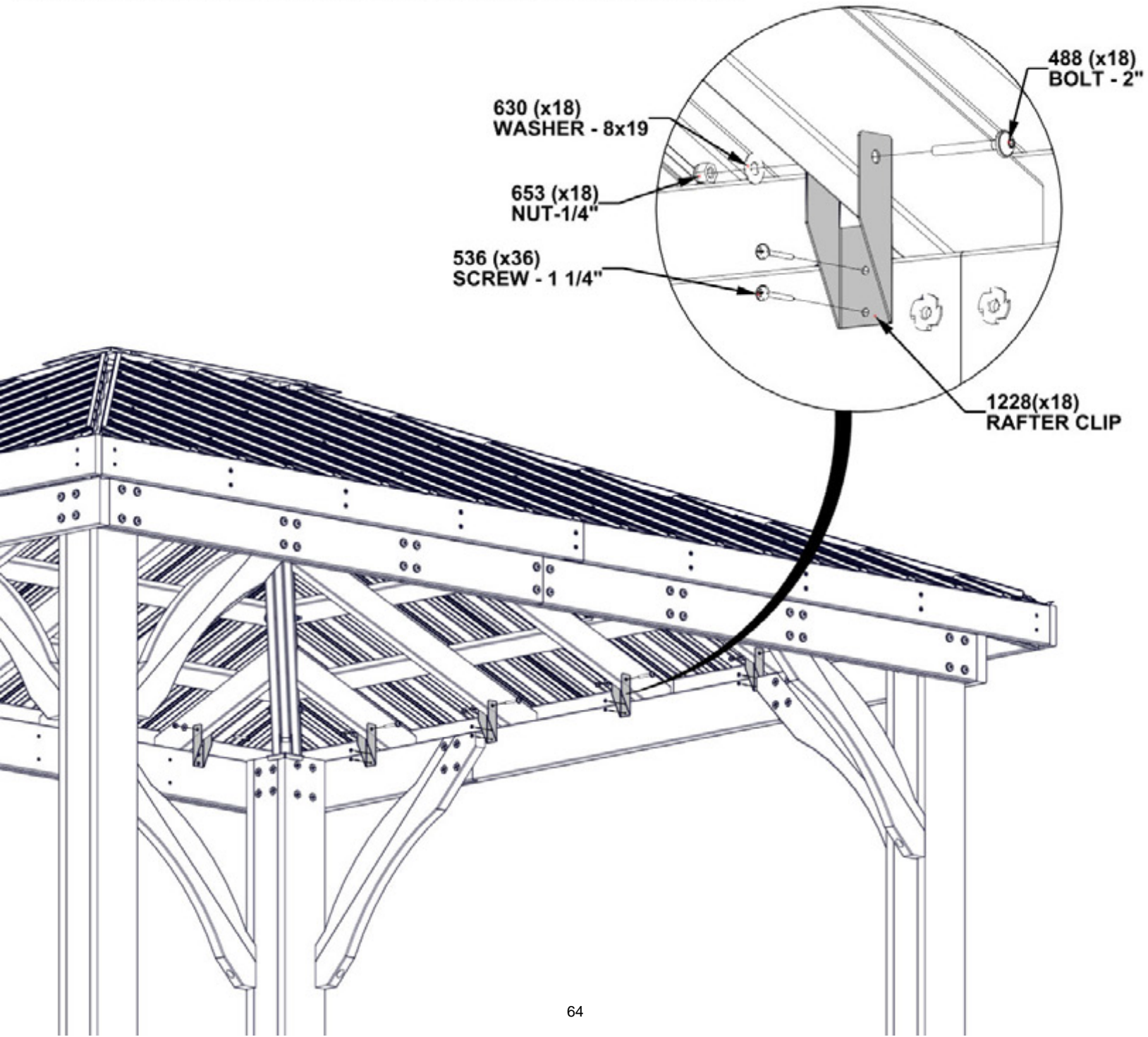

STEP 36 - ROOF ASSEMBLY

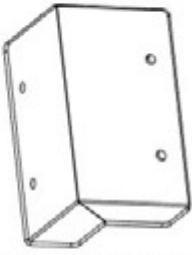

A4M01185 CORNER BRACKET
(x4)

Qty	PART NUMBER	DESCRIPTION
16	H100392	SCREW PWH 8x3/4 BLK

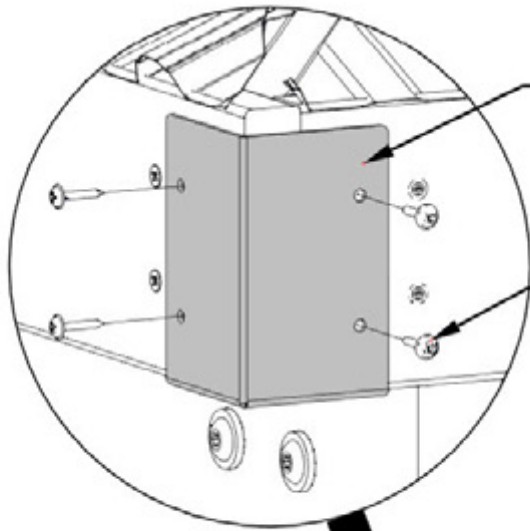

1185(x1)
CORNER BRACKET

REPEAT ON ALL FOUR CORNERS

392 (x4)
SCREW - 3/4"

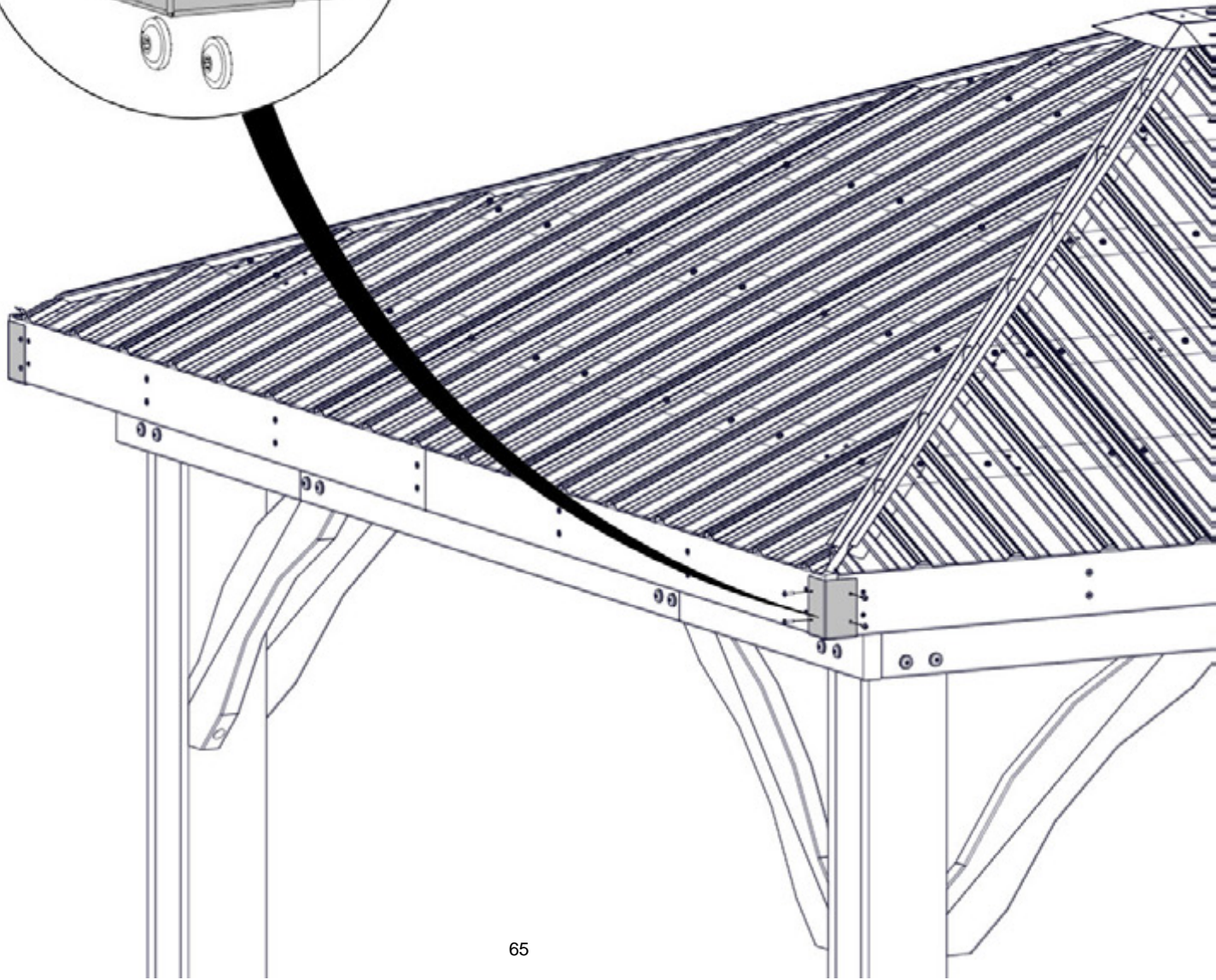

STEP 37 - 12FT ROOF TRIM



Qty	PART NUMBER	DESCRIPTION
20	H100759	SCREW SELF TAPPING 1/4x1



TIPS:

- START ON THE LEFT SIDE OF THE 12FT PANEL.
- SLIDE EDGE TRIM PIECES TOGETHER AS SHOWN BELOW.
- MAKE SURE ALL PANELS ARE COVERED BEFORE INSTALLING SCREWS.
- INSTALL H100759 AS SHOWN.

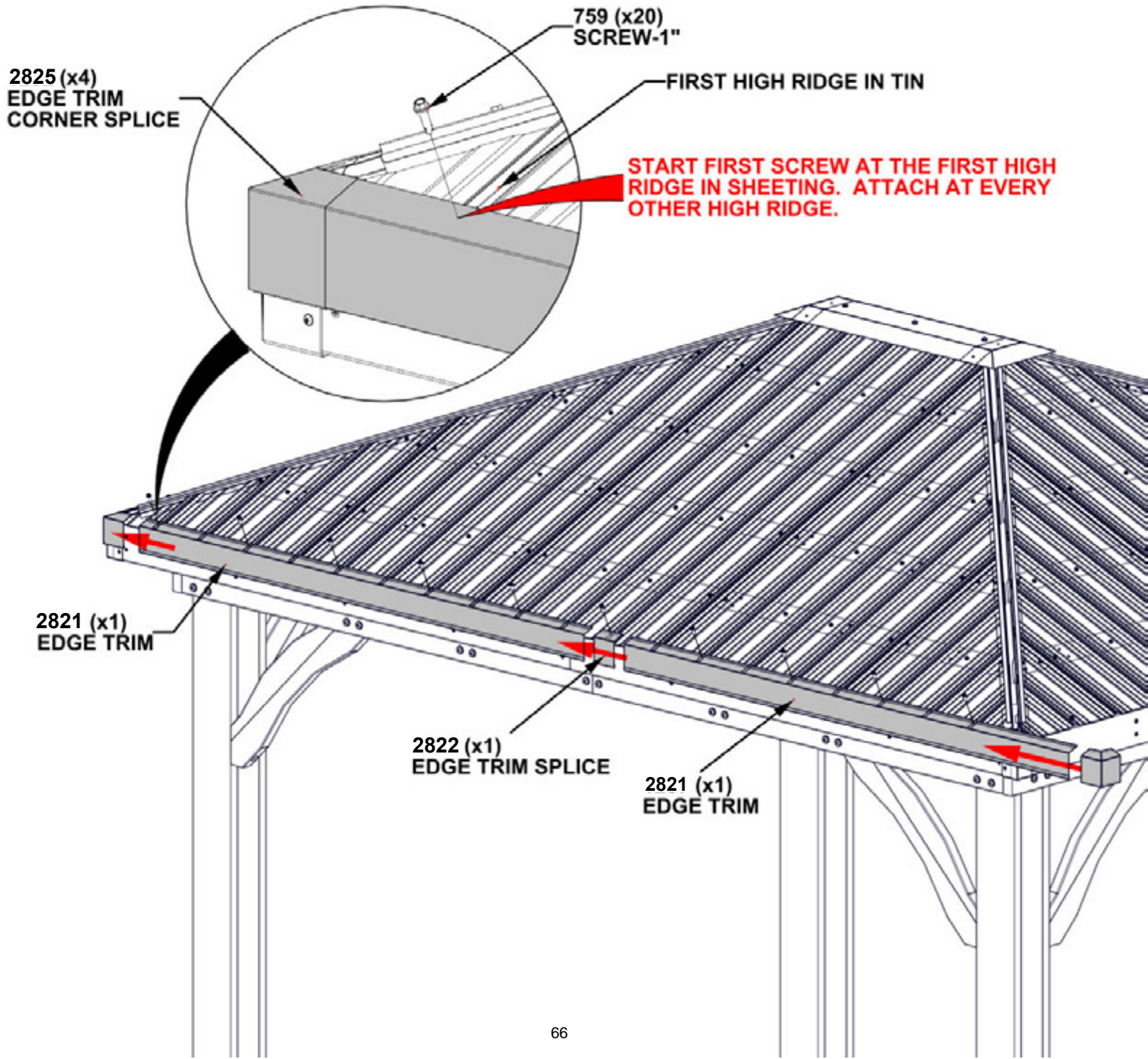

STEP 38 - 10FT ROOF TRIM

Qty	PART NUMBER	DESCRIPTION
16	H100759	SCREW SELF TAPPING 1/4x1



A4M02900 EDGE TRIM
(x4)



A4M02822 EDGE TRIM SPLICE
(x2)

TIPS:

- START ON THE LEFT SIDE OF THE 12FT PANEL.
- SLIDE EDGE TRIM PIECES TOGETHER AS SHOWN BELOW.
- MAKE SURE ALL PANELS ARE COVERED BEFORE INSTALLING SCREWS.
- INSTALL H100759 AS SHOWN.

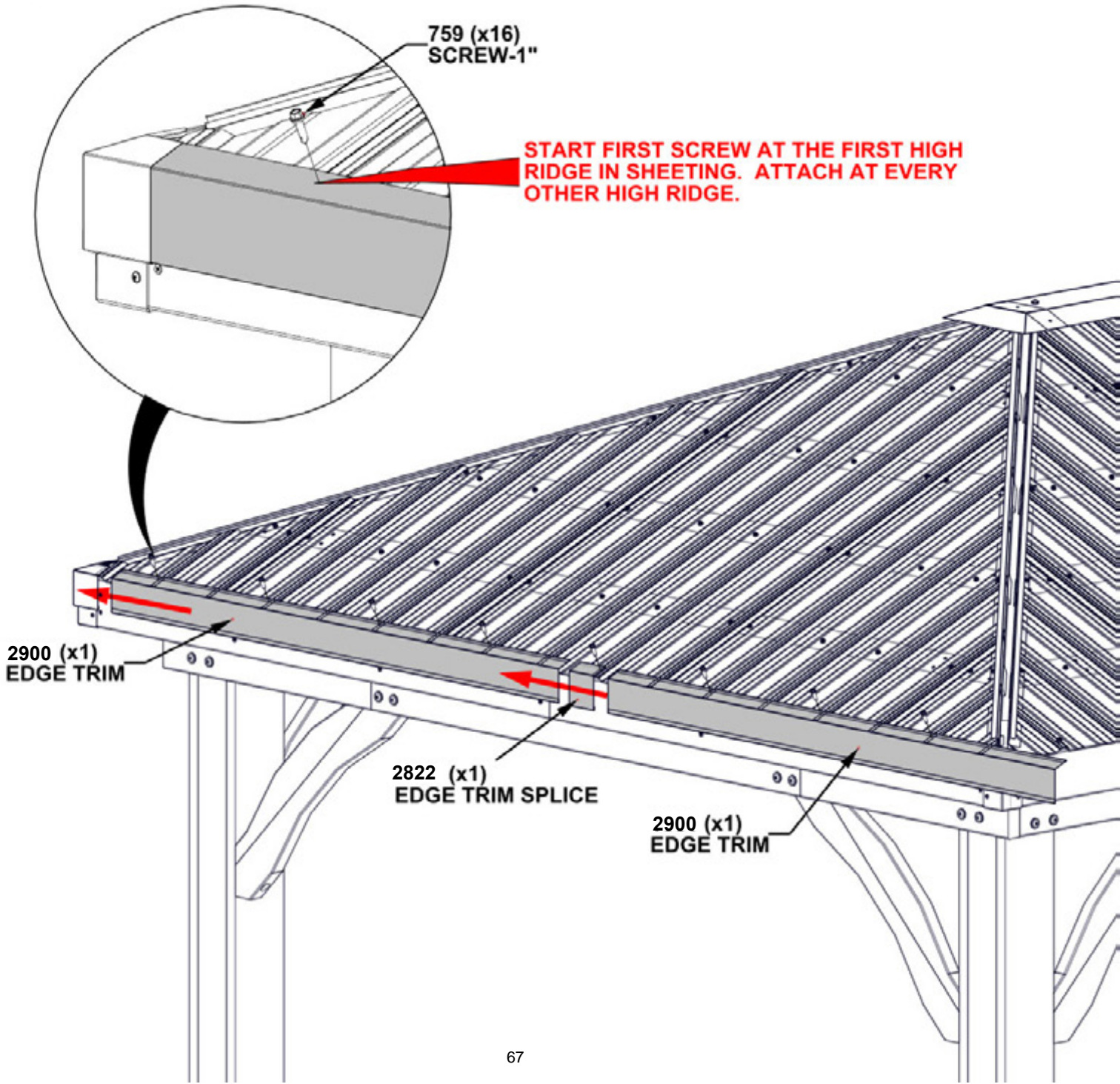

STEP 39 - ROOF ASSEMBLY

Qty	PART NUMBER	DESCRIPTION
8	H100759	SCREW SELF TAPPING 1/4x1



A4M02907 CORNER RIDGE CAP
(x4)

- TIPS:**
- SLIDE CORNER RIDGE CAP ONTO ROOF RIDGE CAP CHANNEL AS SHOWN.
 - DO NOT PUSH ALL THE WAY TO THE TOP. FLUSH WITH CORNER OF GAZEBO AS SHOWN.

REPEAT ON ALL FOUR CORNERS

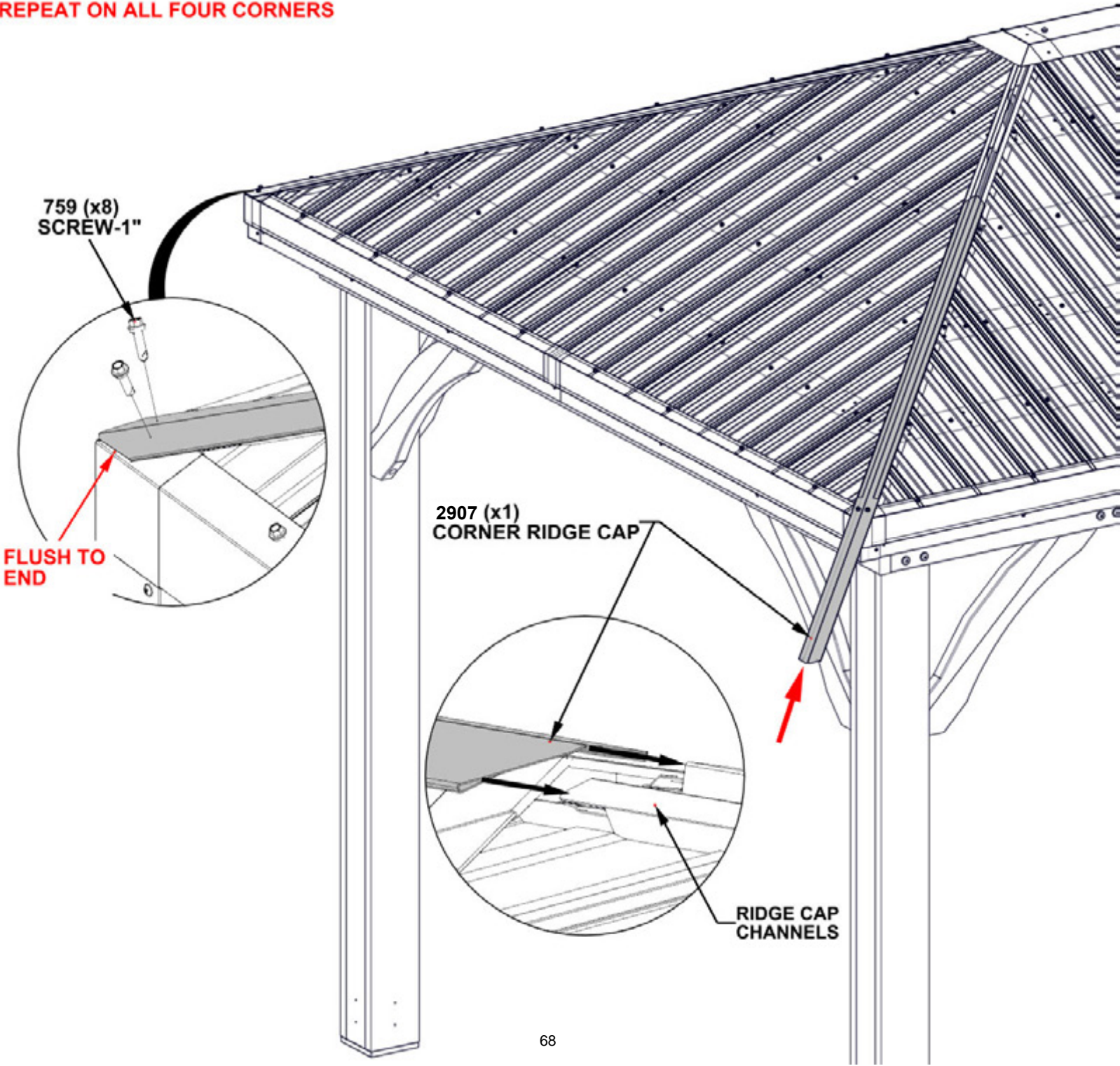

STEP 40 - GAZEBO ASSEMBLY

Qty	PART NUMBER	DESCRIPTION
32	H100471	LAG SCREW WH 5/16x1 1/2 BLK



A4M01793 POST ANCHORING PLATE
(x8)



A4M01794 POST PLATE
(x8)

TIPS:

- ALL 1236 STEEL POST PLATES GO ON THE INSIDES OF THE POST AS SHOWN.
- ALL 1235 STEEL POST ANCHORING PLATES GO ON THE OUTSIDE OF THE POST AS SHOWN.

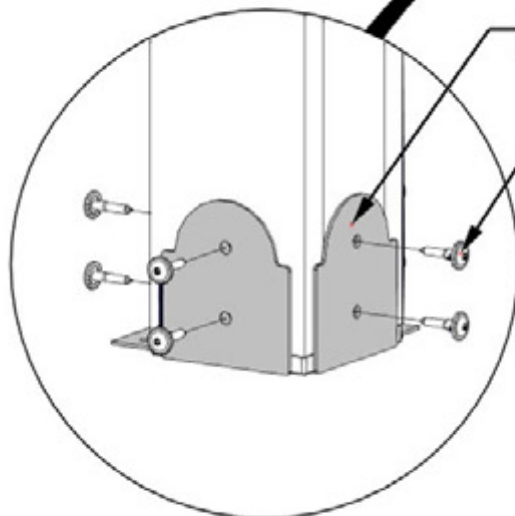
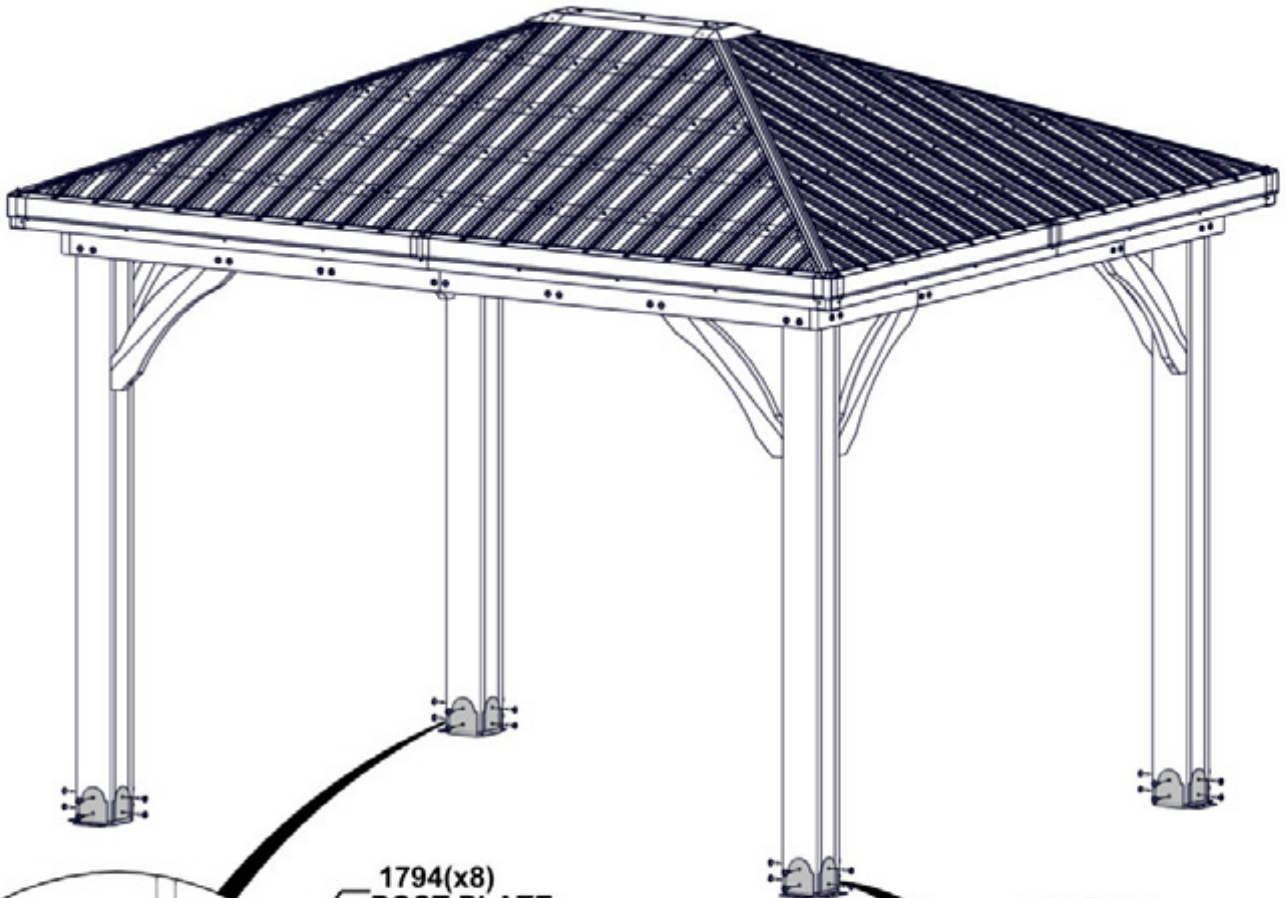

1794(x8)
POST PLATE

471 (x32)
LAG SCREW - 1 1/2"

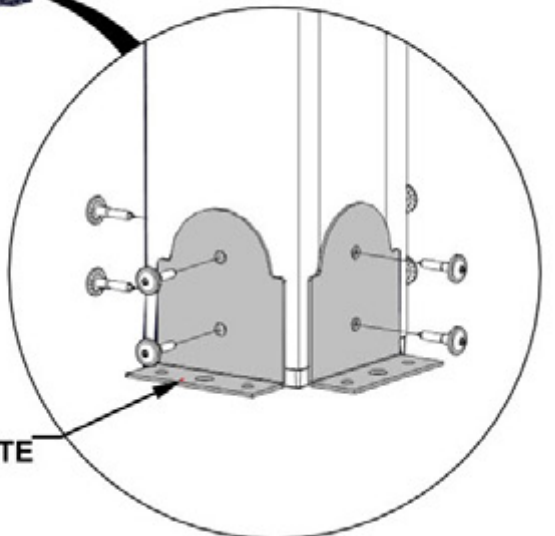

1793 (x8)
POST ANCHORING PLATE

STEP 41 - GAZEBO ASSEMBLY



QTY	PART NUMBER	DESCRIPTION
4	H100536	SCREW PWH 8x1 1/4 BLK

A4M02158
BYD ID TAG PATIO
(x1)

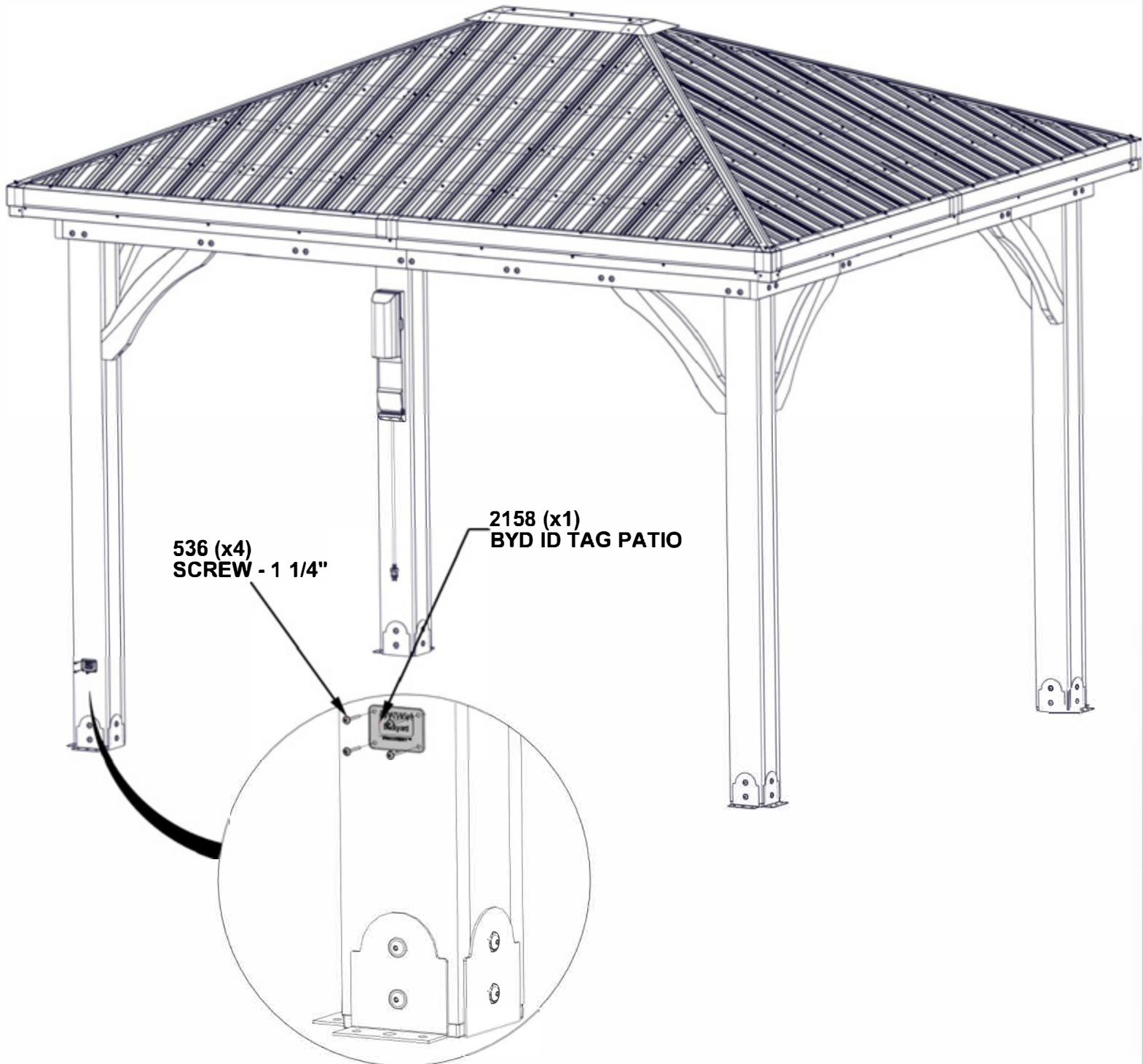

STEP 42 - GAZEBO ASSEMBLY

QTY	PART NUMBER	DESCRIPTION
16	H100630	WASHER FLAT 8x19 BLK
16	H100120	CONCRETE ANCHOR 1/4"x2"

NOTES:
MANUFACTURER RECOMMENDS INSTALLATION ON CONCRETE POST PADS, SEE BELOW FOR INSTILLATION ON A WOOD DECK, YOU MUST ENSURE THERE IS AMPLE STRUCTURAL SUPPORT UNDER DECK. SCREWS ARE NOT PROVIDED TO ATTACH TO A DECK

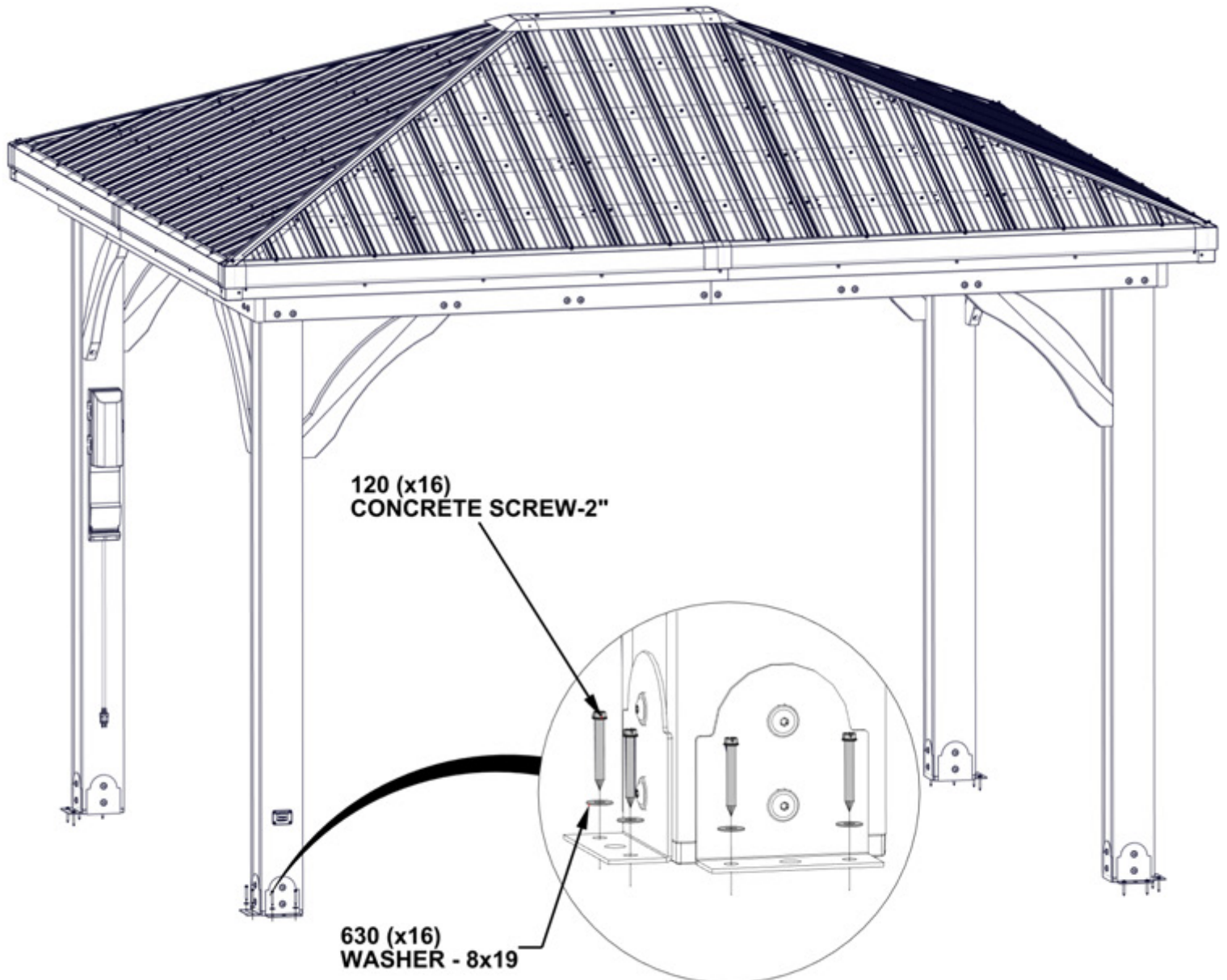

STEP 43 - GAZEBO ASSEMBLY (OPTIONAL)

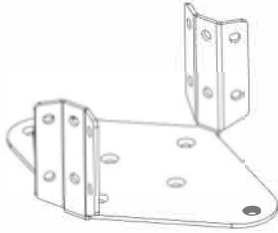

A4M02501 FAN MOUNT BRACKET
(x1)

QTY	PART NUMBER	DESCRIPTION
4	H100382	SCREW PFH 8x1 3/4 BLK

NOTE:

- ATTACH YOUR ELECTRICAL BOX (SOLD SEPERATELY) WITH THE PROVIDED HOLES IN FAN MOUNT BRACKET.
- PLACE FAN MOUNT BRACKET ON RIDGE BEAMS AND MOVE TO DESIRED FAN LOCATION.
- ROTATE BRACKET UNTIL MOUNTING FLANGES ALIGN BEST WITH RIDGE BEAMS.

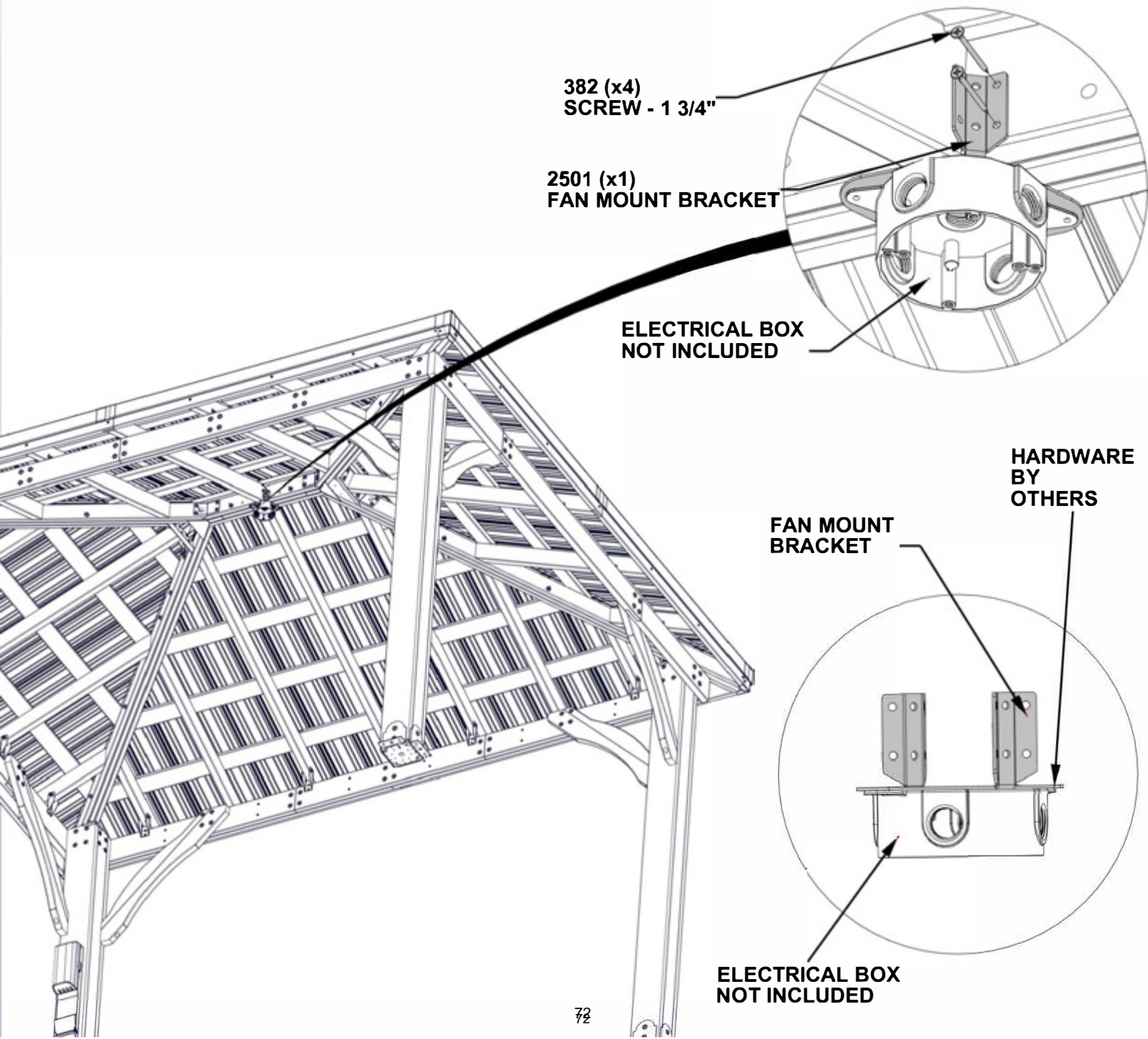

382 (x4)
SCREW - 1 3/4"

2501 (x1)
FAN MOUNT BRACKET

ELECTRICAL BOX
NOT INCLUDED

HARDWARE
BY
OTHERS

FAN MOUNT
BRACKET

ELECTRICAL BOX
NOT INCLUDED

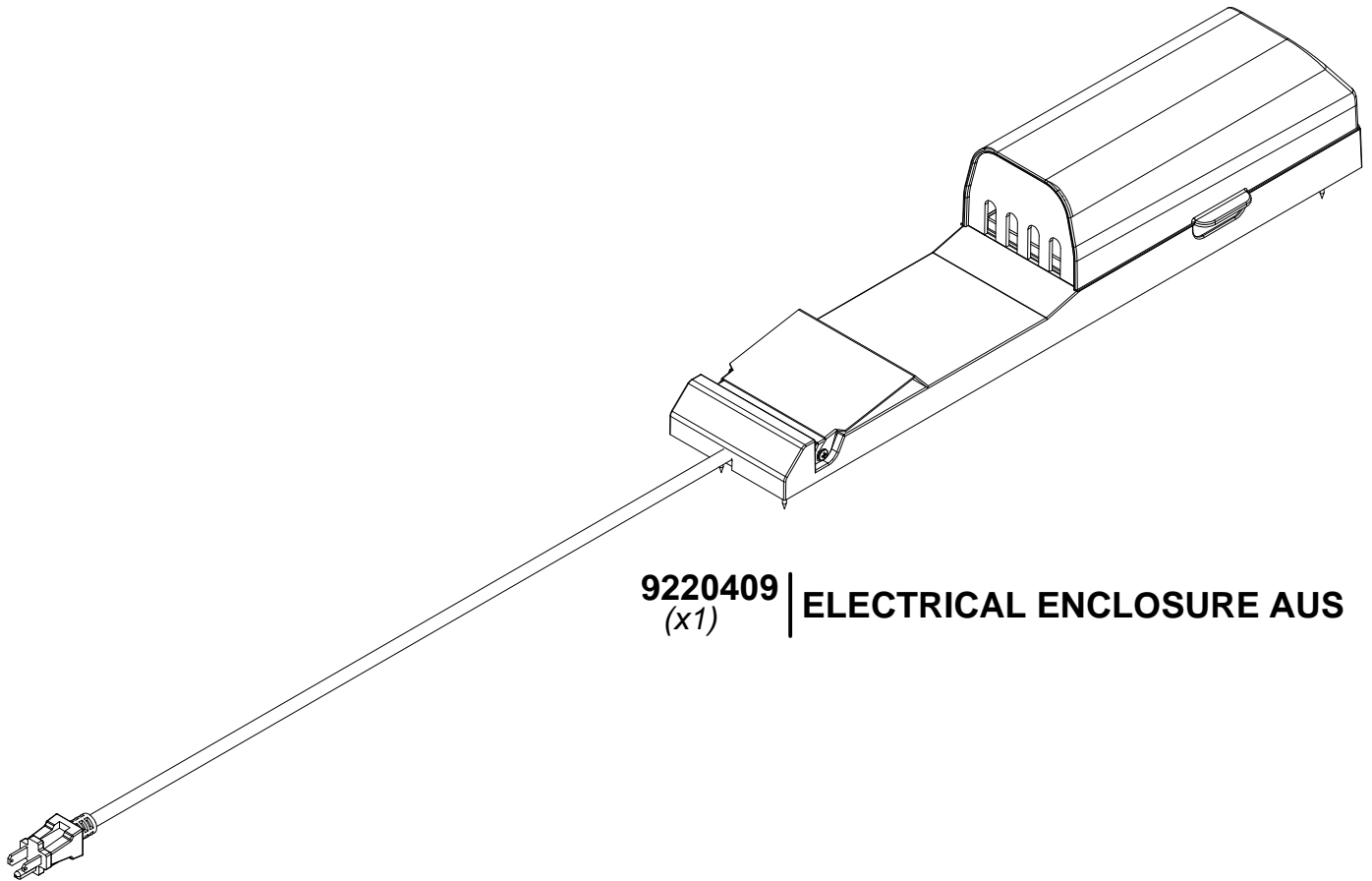

9220409 | **ELECTRICAL ENCLOSURE AUS**
(x1)

FOR POWERPORT INSTALLATION REFER TO ASSEMBLY INSTRUCTIONS THAT COME PACKAGED WITH THE POWERPORT KIT. INSTALL ON ANY POST THAT IS DESIRED. FOLLOW DIRECTIONS FOR PROPER INSTALLATION.