



Manufactured by:
Backyard Discovery
3305 Airport Drive, Pittsburg, KS 66762
800-856-4445

Backyard Discovery Australia Pty Ltd 2/7 Hood Street, Hampton VIC 3188, Phone: 1800-087-941

20x12 Barrington Gazebo

MODEL # : 2406124



Please visit www.backyarddiscovery.com
For the most up to date assembly manual, to register your product, or to order replacement parts *Para obtener instrucciones en español, visite*
www.backyarddiscovery.com



EASY STEP-BY-STEP
3D INTERACTIVE INSTRUCTIONS
DOWNLOAD THE FREE APP



OWNER'S MANUAL - BASIC SETUP DIMENSIONS & ASSEMBLY NOTES

It is critically important that you start with square and level footings, concrete pad or deck to attach your structure

- Pay close attention to the items needed for each step. Make sure you are using the correct hardware for each step. Using incorrect hardware may result in improper assembly
- Remember to double check for underground utilities and overhead electrical lines

Post mounts are provided with your structure which allows you to permanently install your structure to a pre-existing or new wood or concrete surface. See Anchor Instructions for further details and recommendations.

- The hardware to attach the post mounts to the structure is included.
- The hardware to mount the structure permanently to a concrete surface is included.
- The hardware to mount the structure permanently to a wood deck is NOT included and will need to be purchased separately. You must ensure there is ample structural support under the deck before permanently attaching.

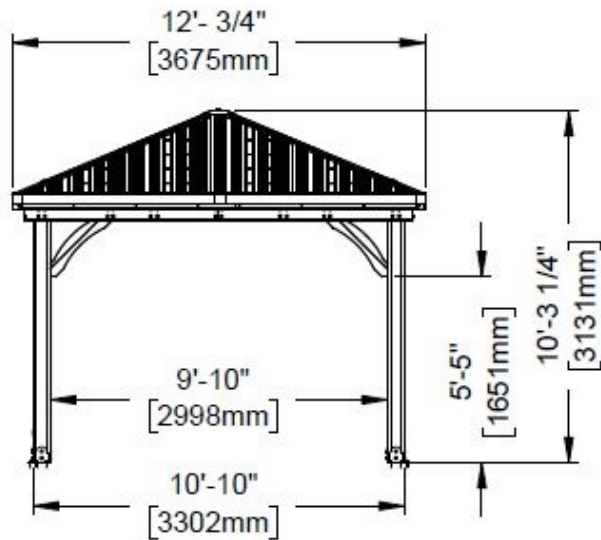
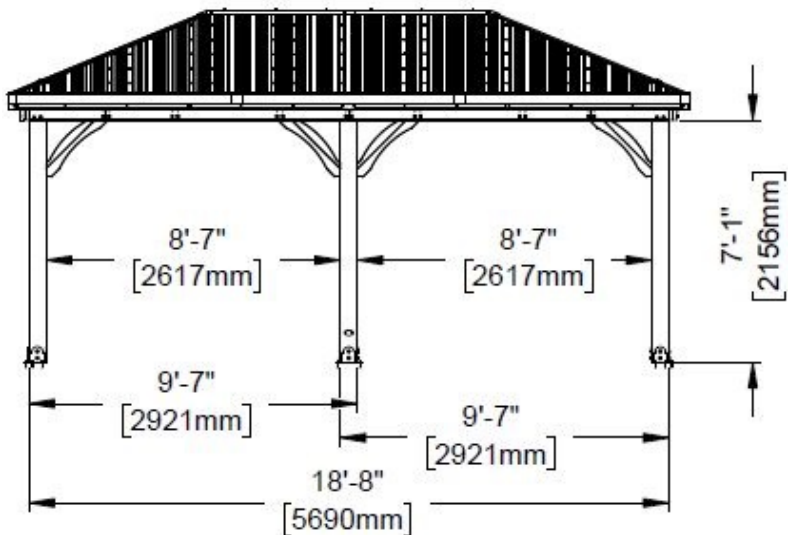
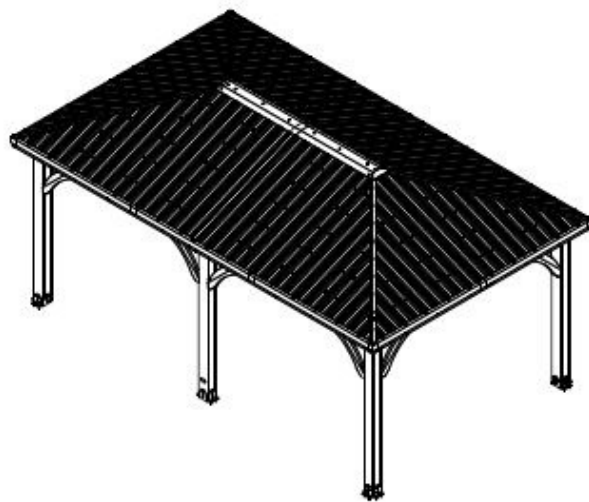
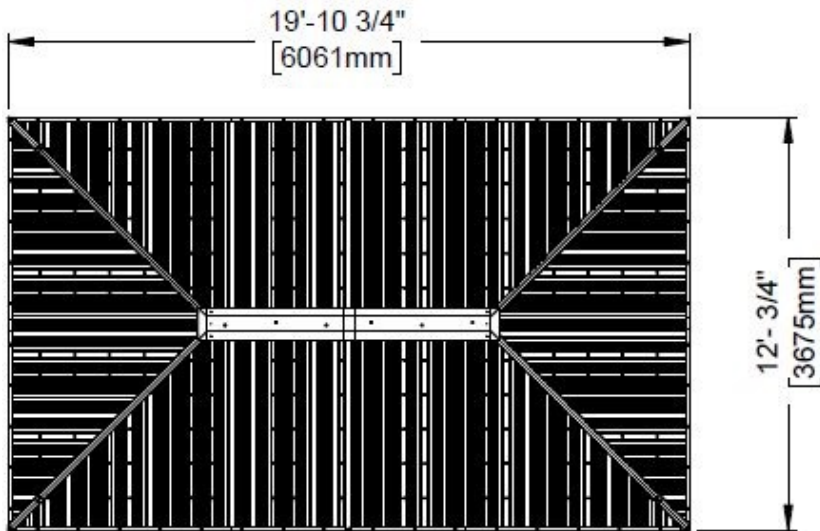

OWNER'S MANUAL - ANCHORING LAYOUT

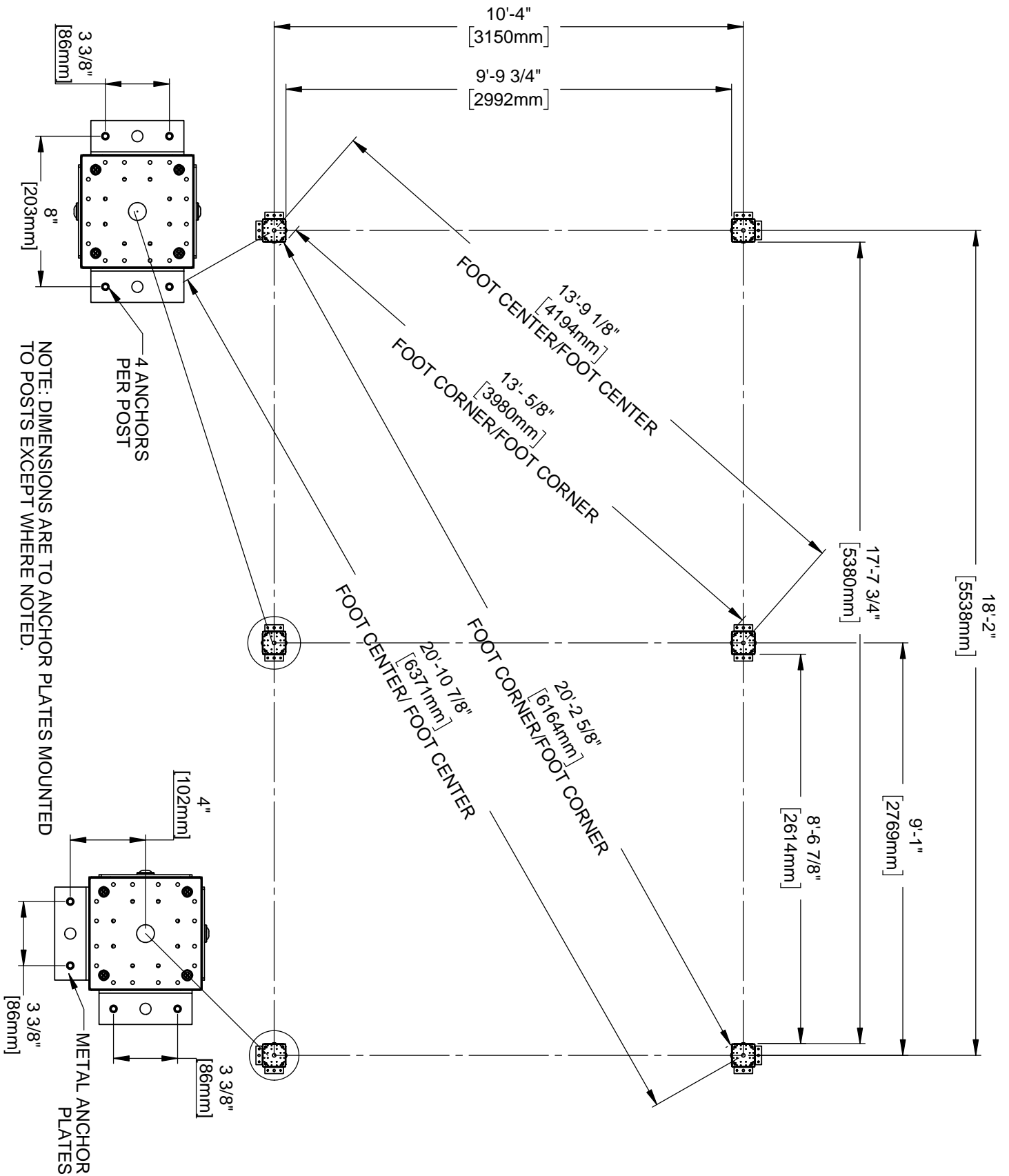

OWNER'S MANUAL - PARTS IDENTIFICATION

WOOD COMPONENTS (NOT TO SCALE)



D01 BEAM - W4L17514
(x4) 1 7/16"x5 1/4"x45 3/16" (36x134x1148)



D02 BEAM - W4L17515
(x2) 1 7/16"x5 1/4"x45 1/4" (36x134x1150)



D03 BEAM - W4L17516
(x4) 1 7/16"x5 1/4"x67 13/16" (36x134x1723)



D04 BEAM - W4L17517
(x4) 1 7/16"x5 1/4"x87 15/16" (36x134x2233)



D05 BEAM - W4L17518
(x2) 1 7/16"x5 1/4"x48 3/16" (36x134x1224)



D06 BEAM - W4L17519
(x4) 1 7/16"x5 1/4"x84 15/16" (36x134x2157)



D07 BEAM - W4L17520
(x4) 1 7/16"x5 1/4"x27 1/16" (36x134x688)



H01 RAFTER - W4L17521
(x4) 15/16"x3 3/8"x54 1/8" (24x86x1374)



H02 RAFTER - W4L17522
(x4) 15/16"x3 3/8"x39 3/8" (24x86x1000)



H03 RIDGE - W4L17523
(x2) 15/16"x3 3/8"x32 5/16" (24x86x821)



H04 RIDGE - W4L17524
(x2) 15/16"x3 3/8"x63 11/16" (24x86x1618)



H05 RAFTER - W4L17525
(x2) 15/16"x3 3/8"x68 9/16" (24x86x1742)



Q01 FASCIA - W4L17526
(x2) 15/16"x4 7/16"x65 15/16" (24x112x1675)



Q02 FASCIA - W4L17527
(x2) 24x4 7/16"x80 1/2" (24x112x2044)

OWNER'S MANUAL - PARTS IDENTIFICATION

WOOD COMPONENTS (NOT TO SCALE)



H06 RAFTER - W4L17528
(x2) 15/16"x3 3/8"x44 1/2" (24x86x1130)



H07 RAFTER - W4L17529
(x2) 15/16"x3 3/8"x53 3/16" (24x86x1351)



H08 RAFTER SUPPORT - W4L17530
(x2) 15/16"x3 3/8"x10 11/16" (24x86x272)



H09 RAFTER - W4L17531
(x2) 15/16"x3 3/8"x53 3/16" (24x86x1351)



H10 RAFTER - W4L17532
(x2) 15/16"x3 3/8"x44 1/2" (24x86x1130)



E01 RAFTER - W4L17533
(x2) 1 3/8"x3 3/8"x22" (36x86x557)



E02 RAFTER - W4L17534
(x2) 1 7/16"x3 3/8"x45 7/16" (36x86x1155)



E06 RAFTER - W4L17538
(x2) 1 7/16"x3 3/8"x21 15/16" (36x86x557)



E05 RAFTER - W4L17537
(x2) 1 7/16"x3 3/8"x45 7/16" (36x86x1155)



E03 RAFTER - W4L17535
(x2) 1 7/16"x3 3/8"x69" (36x86x1752)



E04 RAFTER - W4L17536
(x2) 1 7/16"x3 3/8"x69" (36x86x1752)



H11 PURLIN - W4L17539
(x2) 15/16"x3 3/8"x56" (24x86x1422)



H12 PURLIN - W4L17540
(x2) 15/16"x3 3/8"x70 1/2" (24x86x1791)



H13 PURLIN - W4L17541
(x2) 15/16"x3 3/8"x58 3/8" (24x86x1483)



H14 PURLIN - W4L17542
(x2) 15/16"x3 3/8"x43 7/8" (24x86x1114)



H15 PURLIN - W4L17543
(x2) 15/16"x3 3/8"x75 11/16" (24x86x1922)

OWNER'S MANUAL - PARTS IDENTIFICATION

WOOD COMPONENTS (NOT TO SCALE)



H16 PURLIN - W4L17544
(x2) 15/16"x3 3/8"x51 7/16" (24x86x1307)



H17 PURLIN - W4L17545
(x2) 15/16"x3 3/8"x27 1/4" (24x86x692)



T01 PURLIN - W4L17546
(x2) 15/16"x1 5/16"x12 7/8" (24x34x327)



H18 RAFTER - W4L17547
(x2) 15/16"x3 3/8"x44 1/2" (24x86x1130)



H19 RAFTER - W4L17548
(x2) 15/16"x3 3/8"x60 5/8" (24x86x1540)



H20 RAFTER SUPPORT - W4L17549
(x2) 15/16"x3 3/8"x46 3/8" (24x86x1177)



Q03 FASCIA - W4L17550
(x4) 15/16"x4 7/16"x63 3/16" (24x112x1605)



E07 RAFTER - W4L17551
(x2) 1 7/16"x3 3/8"x76 1/8" (36x86x1934)



E08 RAFTER - W4L17552
(x4) 1 7/16"x3 3/8"x76 1/8" (36x86x1934)



E09 RAFTER - W4L17553
(x2) 1 7/16"x3 3/8"x67 1/8" (36x86x1705)



E10 RAFTER - W4L17554
(x2) 1 7/16"x3 3/8"x43 5/8" (36x86x1109)



E11 RAFTER - W4L17555
(x2) 1 7/16"x3 3/8"x20 3/16" (36x86x512)



Q04 FASCIA - W4L17556
(x4) 15/16"x4 7/16"x57 1/4" (24x112x1454)



H21 PURLIN - W4L17557
(x4) 15/16"x3 3/8"x72 1/4" (24x86x1835)



H22 PURLIN - W4L17558
(x4) 15/16"x3 3/8"x38 13/16" (24x86x986)

OWNER'S MANUAL - PARTS IDENTIFICATION

WOOD COMPONENTS (NOT TO SCALE)



H23 PURLIN - W4L17559
(x4) 15/16"x3 3/8"x78 3/8" (24x86x1991)



H24 PURLIN - W4L17560
(x4) 15/16"x3 3/8"x20 9/16" (24x86x522)



H25 PURLIN - W4L17561
(x4) 15/16"x3 3/8"x84 1/2" (24x86x2147)



H26 PURLIN - W4L17562
(x4) 15/16"x3 3/8"x72 3/8" (24x86x1838)



H27 PURLIN - W4L17563
(x4) 15/16"x3 3/8"x60 1/4" (24x86x1530)



T02 PURLIN - W4L17564
(x4) 15/16"x1 5/16"x49 3/4" (24x34x1264)



E12 RAFTER - W4L17565
(x2) 3 3/8"x1 7/16"x20 3/16" (36x86x512)



E13 RAFTER - W4L17566
(x2) 1 7/16"x3 3/8"x43 5/8" (36x86x1109)



E14 RAFTER - W4L17567
(x2) 1 7/16"x3 3/8"x67 1/8" (36x86x1705)



H28 RAFTER - W4L17568
(x2) 15/16"x3 3/8"x44 1/2" (24x86x1130)



H29 RAFTER - W4L17569
(x2) 15/16"x3 3/8"x60 5/8" (24x86x1540)



H30 RAFTER SUPPORT - W4L17570
(x2) 15/16"x3 3/8"x46 3/8" (24x86x1177)

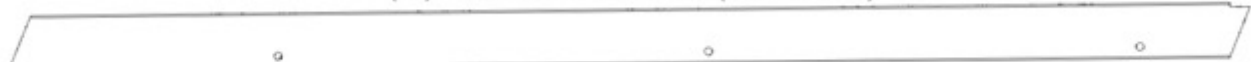

E15 RAFTER - W4L17571
(x2) 1 7/16"x3 3/8"x76 1/8" (36x86x1934)



E16 RAFTER - W4L17572
(x4) 1 7/16"x76 1/8"x3 3/8" (36x86x1934)



E17 COLLAR TIE - W4L17573
(x4) 1 3/8"x3 3/8"x71 5/8" (36x86x1820)

OWNER'S MANUAL - PARTS IDENTIFICATION

WOOD COMPONENTS (NOT TO SCALE)



P01 POST - W2A03202
(x2) 6"x6"x89 1/2" (152x152x2274)



P02 POST - W2A03203
(x2) 6"x6"x89 1/2" (152x152x2274)



P03 MIDDLE POST - W2A03711
(x2) 6"x6"x89 1/2" (152x152x2274)



C01 CORBEL - W2A03198
(x11) 1 7/16"x6 7/16"x35 1/8" (36x163x893)



C02 CORBEL W/TAG - W2A03199
(x1) 1 7/16"x6 7/16"x35 1/8" (36x163x893)

HARDWARE COMPONENTS (NOT TO SCALE)

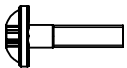

H100171 | BOLT WH BLK
(x32) | 1/4 x 1



H100488 | BOLT WH BLK
(x20) | 1/4 x 2

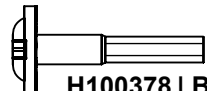

H100378 | BOLT WH BLK
(x4) | 5/16 x 1 3/4

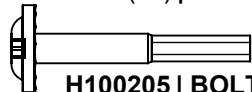

H100205 | BOLT WH BLK
(x4) | 5/16 x 2 1/4

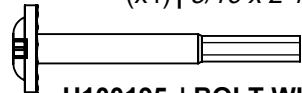

H100195 | BOLT WH BLK
(x44) | 5/16 x 2 3/4

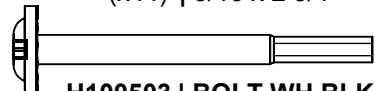

H100503 | BOLT WH BLK
(x8) | 5/16 x 3 1/2

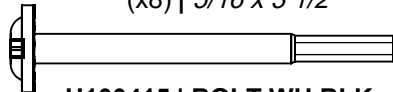

H100415 | BOLT WH BLK
(x20) | 5/16 x 3 3/4

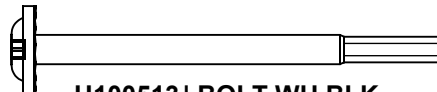

H100513 | BOLT WH BLK
(x48) | 5/16 x 4 1/4

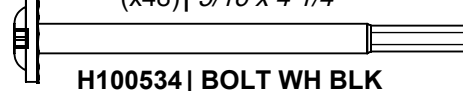

H100534 | BOLT WH BLK
(x6) | 5/16 x 4 1/2

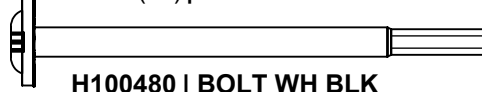

H100480 | BOLT WH BLK
(x6) | 5/16 x 4 3/4

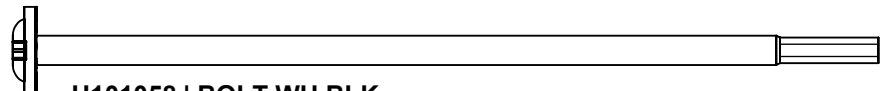

H101058 | BOLT WH BLK
(x40) | 5/16 x 8 3/4

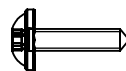

H100460 | LAG SCREW WH BLK
(x24) | 1/4 x 1

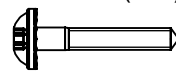

H100403 | LAG SCREW WH BLK
(x2) | 1/4 x 1 1/2

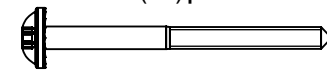

H100792 | LAG SCREW WH BLK
(x18) | 1/4 x 3

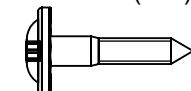

H100471 | LAG SCREW WH BLK
(x48) | 5/16 x 1 1/2

OWNER'S MANUAL - PARTS IDENTIFICATION

HARDWARE COMPONENTS (NOT TO SCALE)

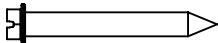

H100120 | CONCRETE ANCHOR
(x24)



H101030 | SCREW CONFIRMAT BLK
(x144) | 7 x 2



H100392 | SCREW PWH BLK
(x24) | 8 x 3/4

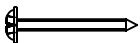

H100536 | SCREW PWH BLK
(x40) | 8 x 1 1/4



H100385 | SCREW PFH BLK
(x200) | 8 x 1



H100200 | SCREW PFH BLK
(x40) | 8 x 1 1/2



H100382 | SCREW PFH BLK
(x48) | 8 x 1 3/4



H100391 | SCREW PFH BLK
(x344) | 8 x 2



H100483 | SCREW PFH BLK
(x64) | 8 x 2 1/4



H100759 | SCREW TAPPING
(x66) | 1/4 x 1



H100833 | SCREW WOODGRIP
(x400) | 10 x 3/4

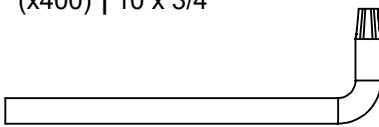

H100114 | TORX WRENCH
(x1) | T-30

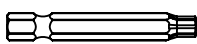

H100147 | TORX BIT
(x1) | T-30

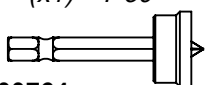

H100764 | SCREW SETTER
(x1)



H100653 | NUT LOCK BLK
(x20) | 1/4



H100479 | NUT LOCK BLK
(x40) | 5/16



H100398 | T-NUT BLK
(x32) | 1/4



H100379 | T-NUT BLK
(x140) | 5/16



H100405 | WASHER LOCK EXT BLK
(x12) | 6 x 15



H100198 | WASHER LOCK EXT BLK
(x172) | 12 x 19



H100630 | WASHER FLAT BLK
(x44) | 8 x 19



H100770 | WASHER FLAT BLK
(x40) | 5/16



H100478 | WASHER FLAT BLK
(x8) | 5/16



H101034 | WEATHER PROOFING WASHER
(x6)



H101114 | RIGHT ANGLE DRILL ADAPTER
(x1)

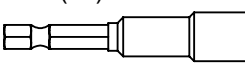

H101106 | SOCKET DRIVER
(x1)

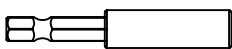

H101100 | MAGNETIC DRIVER
(x1)

OWNER'S MANUAL - PARTS IDENTIFICATION

ACCESSORY COMPONENTS (NOT TO SCALE)



A4M02158 BYD ID TAG
(x1)

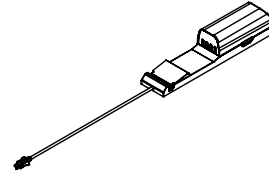

9220409 ELECTRICAL ENCLOSURE AUS
(x1)



A4M01185 CORNER BRACKET
(x4)

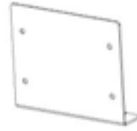

A4M01904 SPLICE PLATE
(x2)

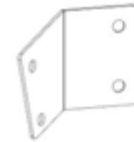

A4M01191 PANEL BRACKET
(x2)

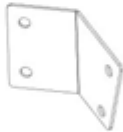

A4M01193 PANEL BRACKET
(x2)

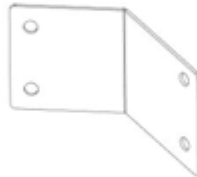

A4M01238 PANEL BRACKET
(x2)

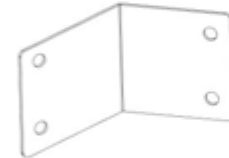

A4M01239 PANEL BRACKET
(x2)



A4M01793 POST ANCHORING PLATE
(x12)



A4M01794 POST PLATE
(x12)

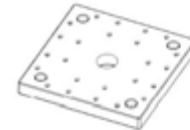

A6P00308 6x6 POST FOOT
(x6)

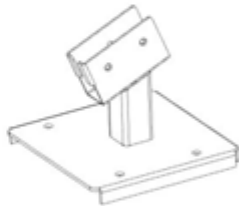

A4M01894 MIDDLE POST CLIP ASSEMBLY
(x2)

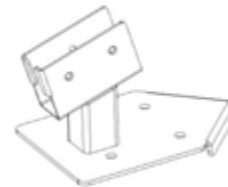

A4M01234 POST CLIP ASSEMBLY
(x4)

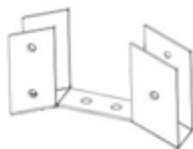

A4M01902 RAFTER HANGER
(x1)



A4M01895 PANEL SUPPORT BRACKET
(x2)

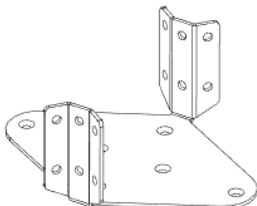

A4M02501 FAN MOUNT BRACKET
(x1)

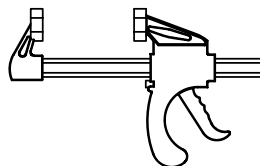

A6P00460 6" QUICK RELEASE BAR CLAMP
(x2)

OWNER'S MANUAL - PARTS IDENTIFICATION

ACCESSORY COMPONENTS (NOT TO SCALE)



A4M02822 EDGE TRIM SPLICE
(x6)



A4M02825 EDGE TRIM CORNER SPLICE
(x4)



A4M01228 RAFTER CLIP
(x20)



A4M01237 ROOF SUPPORT SPLICE CLIP
(x12)



A4M01205 METAL SPACER
(x6)



A4M02850 RIDGE CAP CHANNEL SHORT
(x8)

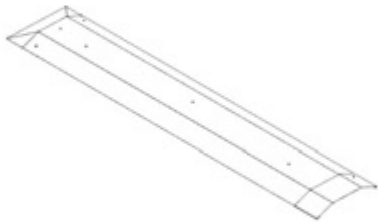

A4M02823 RIDGE PEAK CAP
(x1)

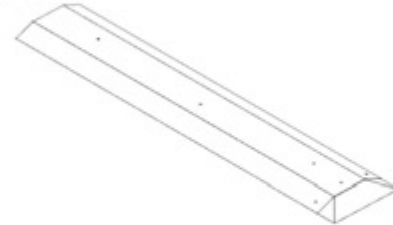

A4M02824 RIDGE PEAK CAP
(x1)

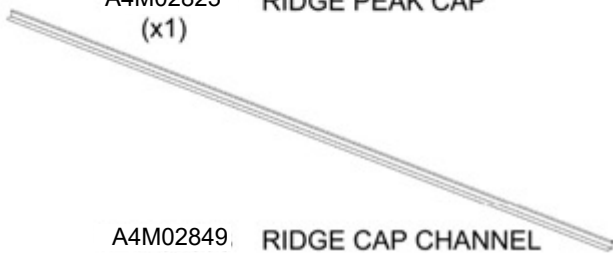

A4M02849 RIDGE CAP CHANNEL
(x4)



A4M02847 RIDGE CAP CHANNEL LONG
(x8)



A4M02820 EDGE TRIM
(x6)

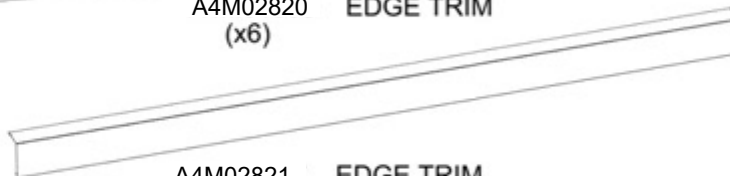

A4M02821 EDGE TRIM
(x4)

OWNER'S MANUAL - PARTS IDENTIFICATION

ACCESSORY COMPONENTS (NOT TO SCALE)



A4M02867 RIDGE CAP SPLICE ASSEMBLY
(x4)

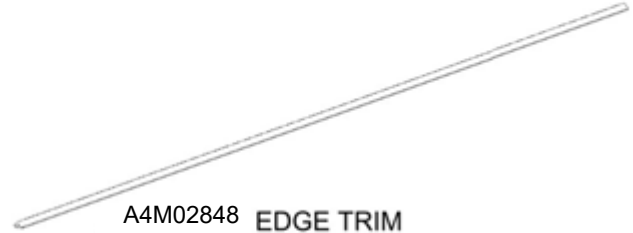

A4M02848 EDGE TRIM
(x2)

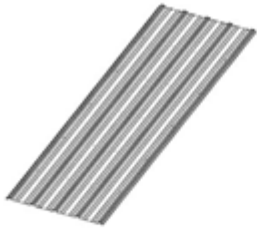

A4M02818 29GA STEEL SHEETING
(x4)



A4M02819 29GA STEEL SHEETING
(x4)



A4M02826 CORNER RIDGE CAP LONG
(x4)



A4M02814-1 29GA STEEL SHEETING
(x2)



A4M02815-2 29GA STEEL SHEETING
(x2)



A4M02816-2 29GA STEEL SHEETING
(x2)



A4M02817-2 29GA STEEL SHEETING
(x2)



A4M02814-2 29GA STEEL SHEETING
(x2)



A4M02813-2 29GA STEEL SHEETING
(x2)



A4M02812-2 29GA STEEL SHEETING
(x2)



A4M02817-1 29GA STEEL SHEETING
(x2)



A4M02816-1 29GA STEEL SHEETING
(x2)

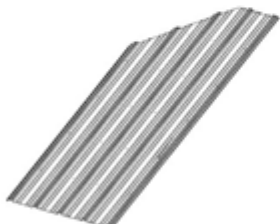

A4M02815-1 29GA STEEL SHEETING
(x2)



A4M02812-1 29GA STEEL SHEETING
(x2)



A4M02813-1 29GA STEEL SHEETING
(x2)

PRE-ASSEMBLY STEP 1 - SORTING PARTS

It is critical for ease of assembly that you take the time to sort and organize the wood and hardware.

WOOD PARTS:

- Organize wood parts by the three-digit, alpha-numeric number stamped on each board (ex. P01).
- If there are multiple boards with the same stamped number, stack those pieces together.
- Stamps can be found on the flat surface of the boards or on the end of the boards.
- Allow yourself plenty of room - the wood pieces can take up a significant amount of space.

NOTE: CARTONS ARE NOT ORGANIZED BY BOARD NUMBER.



HARDWARE PARTS:

- We recommend that you have a separate table to organize the hardware.
- Hardware bags are printed with a seven-digit, alpha-numeric part number.
- You can organize your hardware by part number or group by hardware type (i.e. bolts, nuts, etc.).
- During assembly you only need to reference the last four digits of the number.

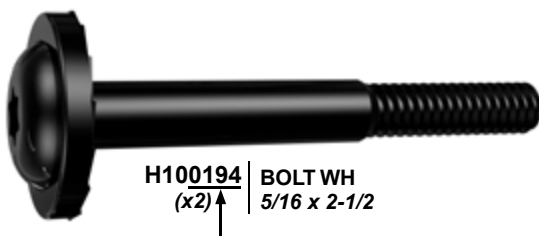

PRE-ASSEMBLY STEP 2 - TOOLS REQUIRED



Cordless Drill or Electric Drill



Drill Attachments:
Phillips Head



1/8" & 3/8" Drill Bits



Phillips Screw Driver



Open End Wrenches 1/2" & 7/16"



3/8" Drive Ratchet, 1/2" & 7/16" STD Sockets, 1/2" & 7/16" Deep Sockets



Tape Measure



Claw Hammer



Rubber Mallet - Optional

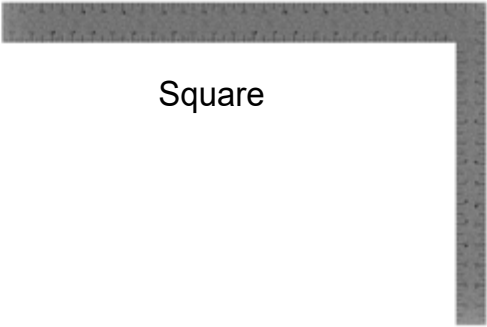

Square



Level 24"

PRE-ASSEMBLY STEP 3 - CHOOSE YOUR ASSEMBLY METHOD

There are several types of assembly instructions available to you.

1. Printed Assembly Manual included with your set
2. BILT APP - 3D interactive instructions
3. Combination of the Printed Manual and BILT APP (Note: Step numbers can differ between the two methods)



The graphic is a rectangular advertisement for the BILT app. At the top left is the BILT logo, which consists of a stylized hexagonal icon with a dot inside, followed by the word "BILT." in a bold, sans-serif font. To the right of the logo is a large QR code. Below the logo and QR code, the text "Scan for easy 3D instructions" is written in a large, bold, sans-serif font. Underneath this, in a smaller font, it says "Download the BILT app before you begin". To the right of this text are two buttons: "Download on the App Store" with the Apple logo and "GET IT ON Google Play" with the Google Play logo. At the bottom of the graphic is a smartphone screen displaying a 3D assembly instruction. The screen shows a grey 3D model of a structure with a horizontal beam and a triangular support. The interface includes a close button (X) in the top right, a menu icon (three dots) below it, a share icon (square with a dot) to the left, and a play/pause button (two vertical bars) at the bottom center. A small notification "Hardware Needed" is visible in the top left corner of the app interface.

STEP 1 - POST ASSEMBLY

QTY	PART NUMBER	DESCRIPTION
12	H100200	SCREW PFH 8x1 1/2 BLK



P01 POST - W2A03202
(x1) 6"x6"x89 1/2" (152x152x2274)



P02 POST - W2A03203
(x1) 6"x6"x89 1/2" (152x152x2274)



P03 MIDDLE POST - W2A03711
(x1) 6"x6"x89 1/2" (152x152x2274)

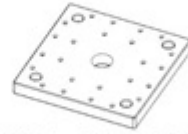

A6P00308 6x6 POST FOOT
(x3)

FOR EASE OF ASSEMBLY, WE RECOMMEND USING SAW HORSES FOR STEPS 1-9.

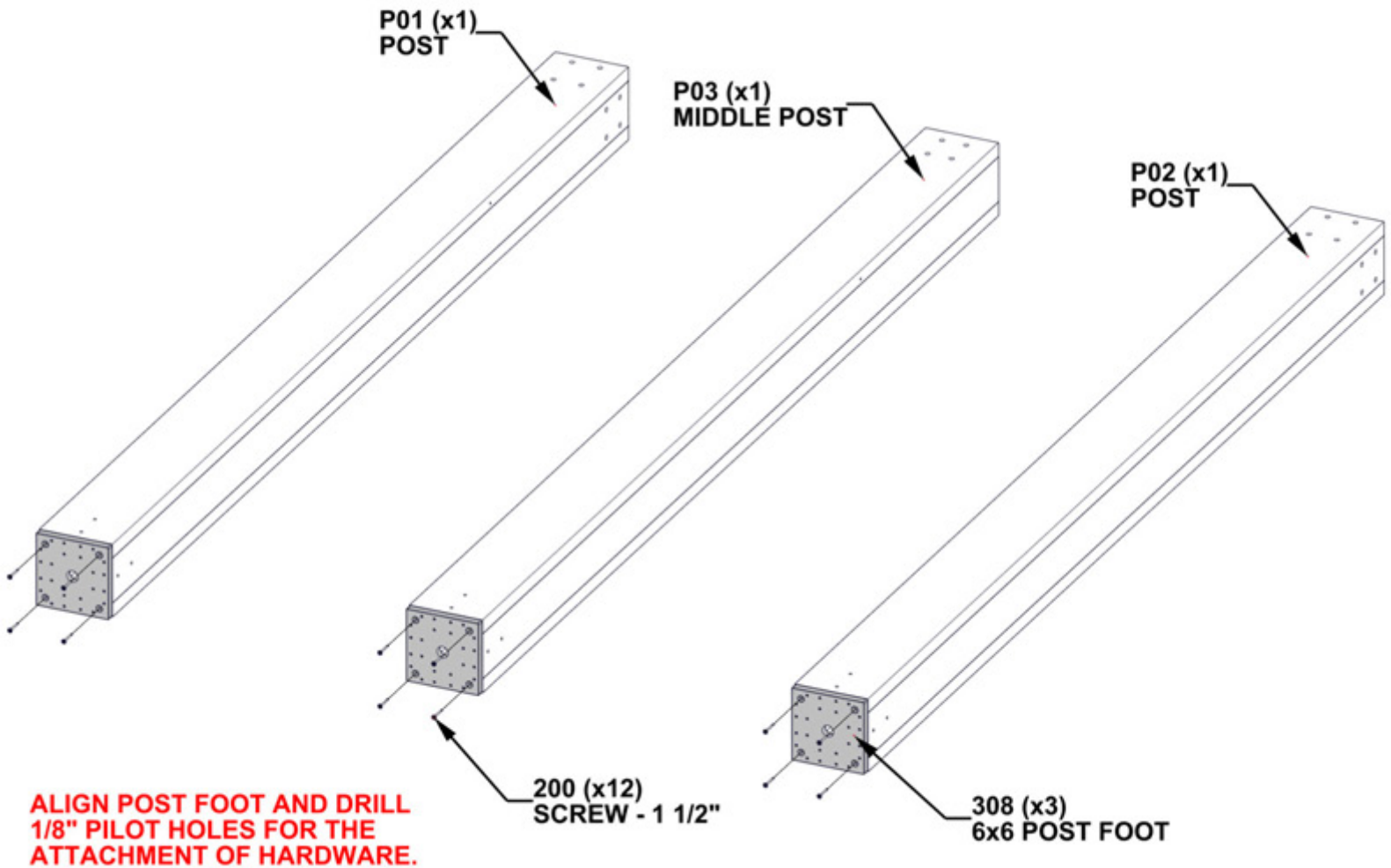

STEP 2 - 12FT BEAM ASSEMBLY

QTY	PART NUMBER	DESCRIPTION
8	H100379	T-NUT 5/16 BLK
8	H100198	WASHER LOCK EXT 8x19
8	H100195	BOLT WH 5/16x2 3/4 BLK



D02 BEAM - W4L17515
 (x1) 1 7/16"x5 1/4"x45 1/4" (36x134x1150)



D03 BEAM - W4L17516
 (x2) 1 7/16"x5 1/4"x67 13/16" (36x134x1723)

INSERT T-NUTS FIRST

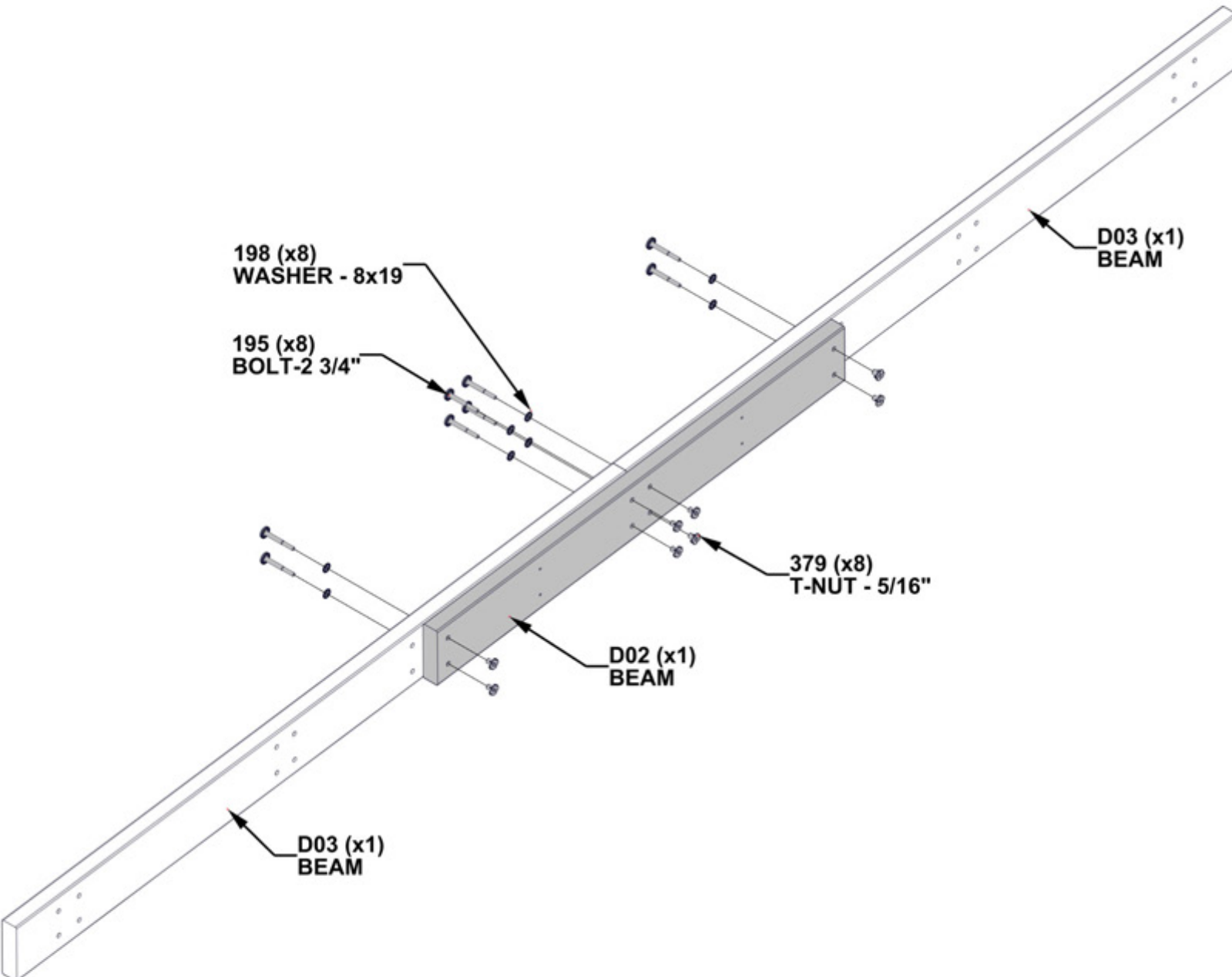

STEP 3- 12FT BEAM ASSEMBLY

QTY	PART NUMBER	DESCRIPTION
4	H100379	T-NUT 5/16 BLK
4	H100195	BOLT WH 5/16x2 3/4 BLK
4	H100198	WASHER LOCK EXT 8x19



D01 BEAM - W4L17514
 (x2) 1 7/16"x5 1/4"x45 3/16" (36x134x1148)

INSERT T-NUTS FIRST

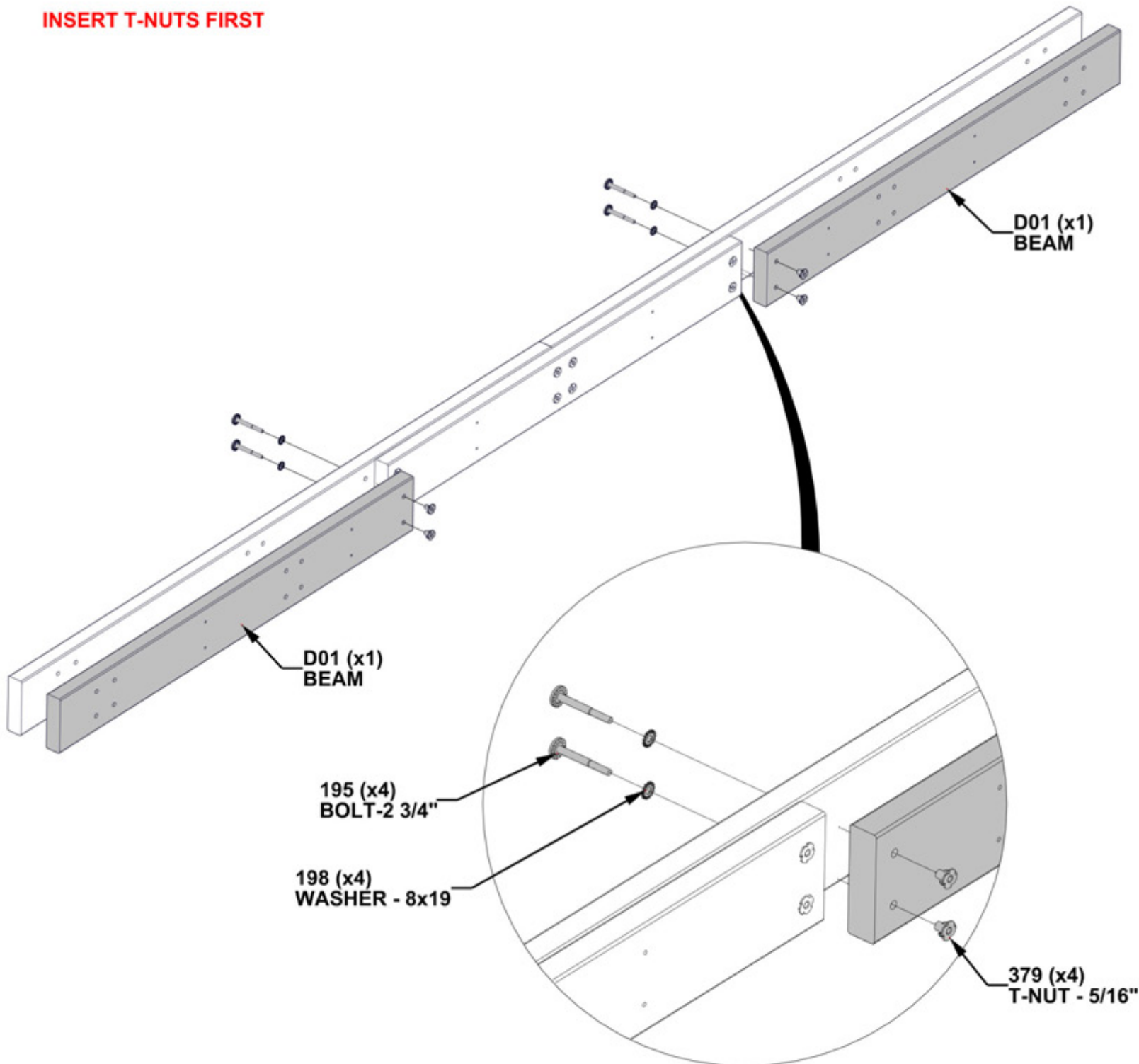

STEP 4 - 12FT BEAM ASSEMBLY

QTY	PART NUMBER	DESCRIPTION
12	H100483	SCREW PFH 8x2 1/4 BLK

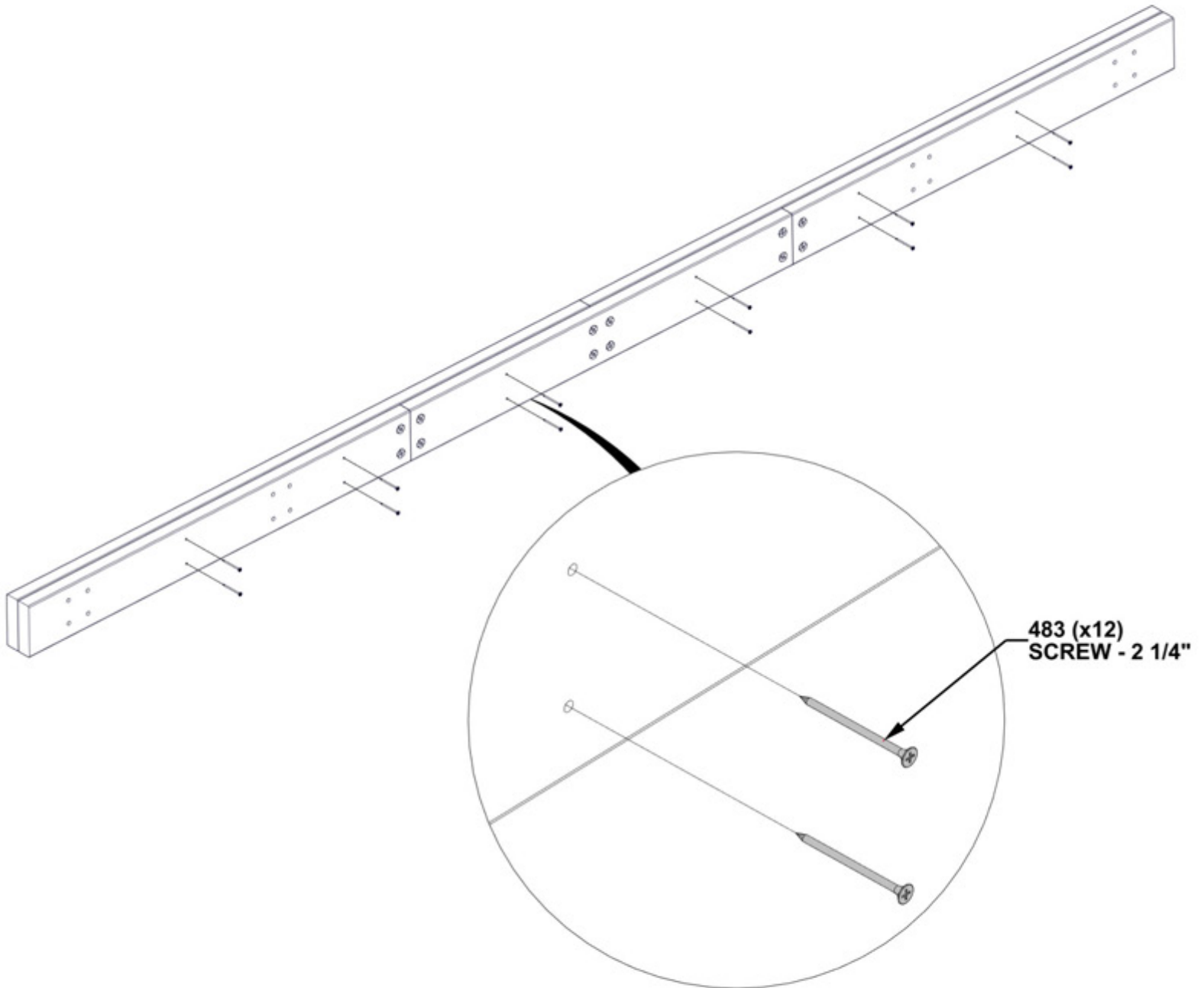
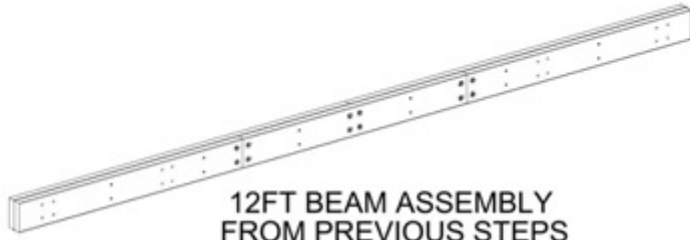

STEP 5 - 12FT BEAM ASSEMBLY

QTY	PART NUMBER	DESCRIPTION
8	H100379	T-NUT 5/16 BLK
8	H101058	BOLT WH 5/16x8 3/4 BLK
8	H100198	WASHER LOCK EXT 8x19

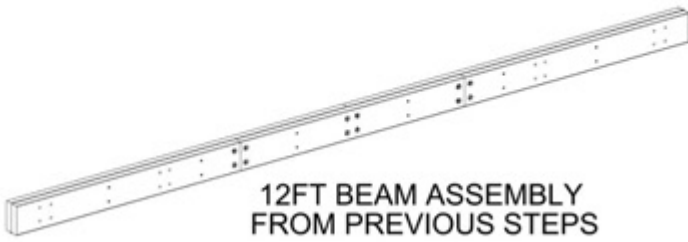

INSERT T-NUTS FIRST

TIPS:
SAW DUST CAN BE LEFT BEHIND IN BOLT HOLES. IF YOU HAVE TROUBLE WITH BOLTS ENGAGING, USE A LONG SCREWDRIVER TO REMOVE THE DEBRIS.

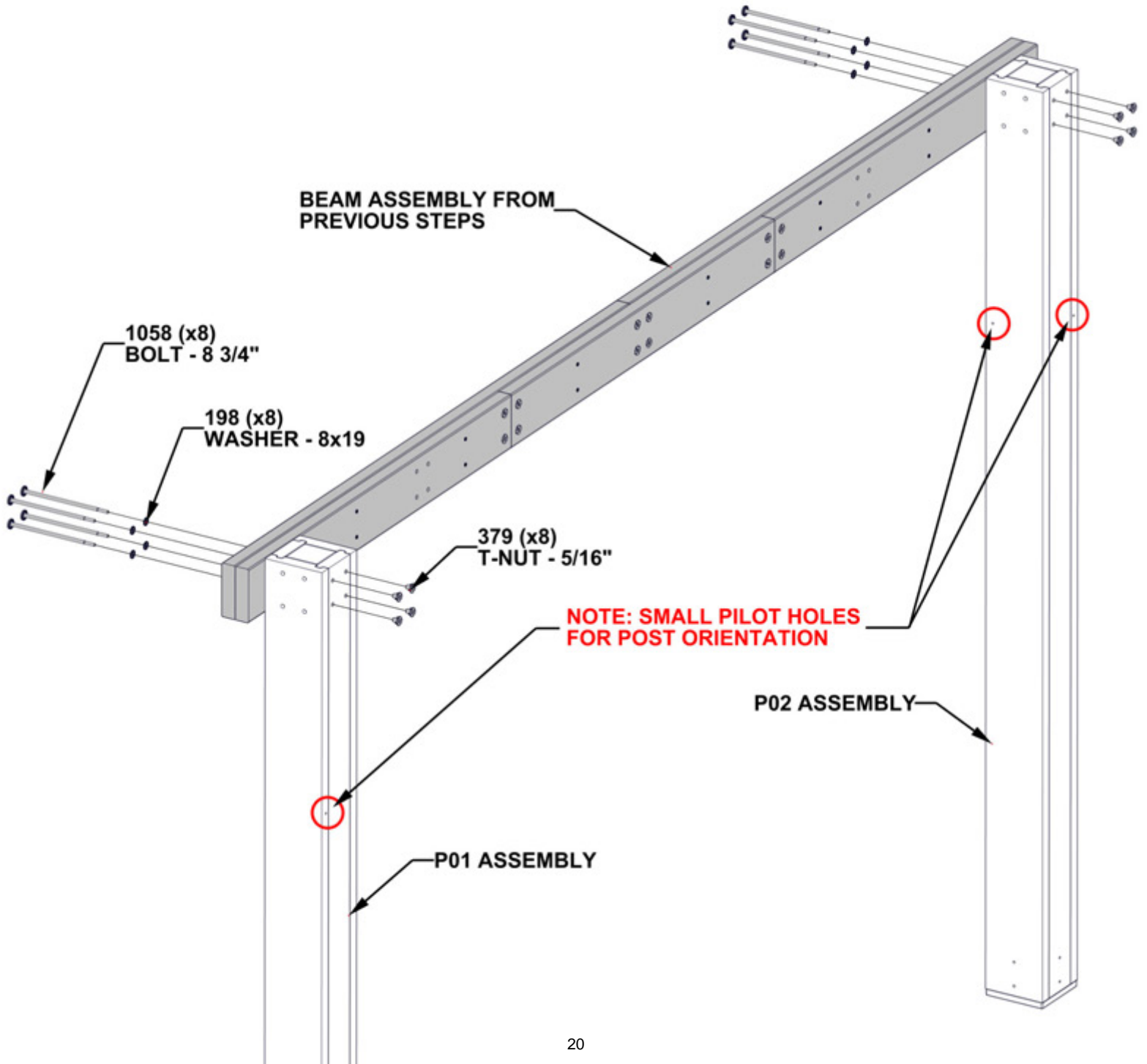

STEP 6 - 12FT BEAM ASSEMBLY

QTY	PART NUMBER	DESCRIPTION
2	H100405	WASHER LOCK EXT 6x15
2	H100792	LAG SCREW WH 1/4x3 BLK
8	H100379	T-NUT 5/16 BLK
8	H100513	BOLT WH 5/16x4 1/4 BLK
8	H100198	WASHER LOCK EXT 8x19



C01 CORBEL - W2A03198
(x2) 1 7/16"x6 7/16"x35 1/8" (36x163x893)

INSERT T-NUTS FIRST

TIPS:
INSERT BOLTS FIRST FOLLOWED BY LAG SCREWS.
TO AVOID WOOD SPLITTING, MAKE SURE LAG SCREWS GO INTO PILOT HOLES.

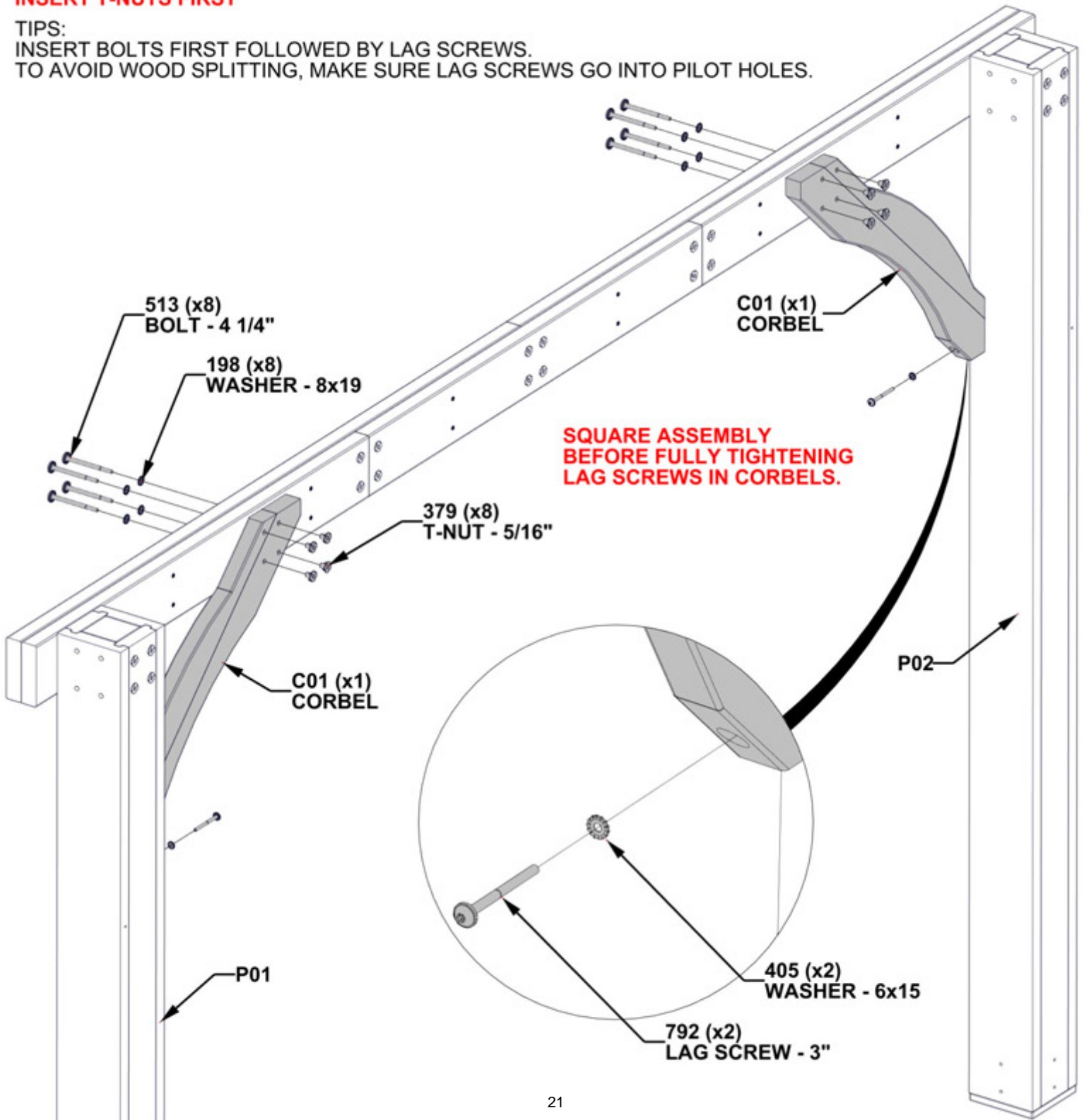

STEP 7 - 12FT BEAM ASSEMBLY

QTY	PART NUMBER	DESCRIPTION
8	H101058	BOLT WH 5/16x8 3/4 BLK
8	H100198	WASHER LOCK EXT 8x19
8	H100379	T-NUT 5/16 BLK



D04 BEAM - W4L17517
(x2) 1 7/16"x5 1/4"x87 15/16" (36x134x2233)



D07 BEAM - W4L17520
(x2) 1 7/16"x5 1/4"x27 1/16" (36x134x688)

INSERT T-NUTS FIRST

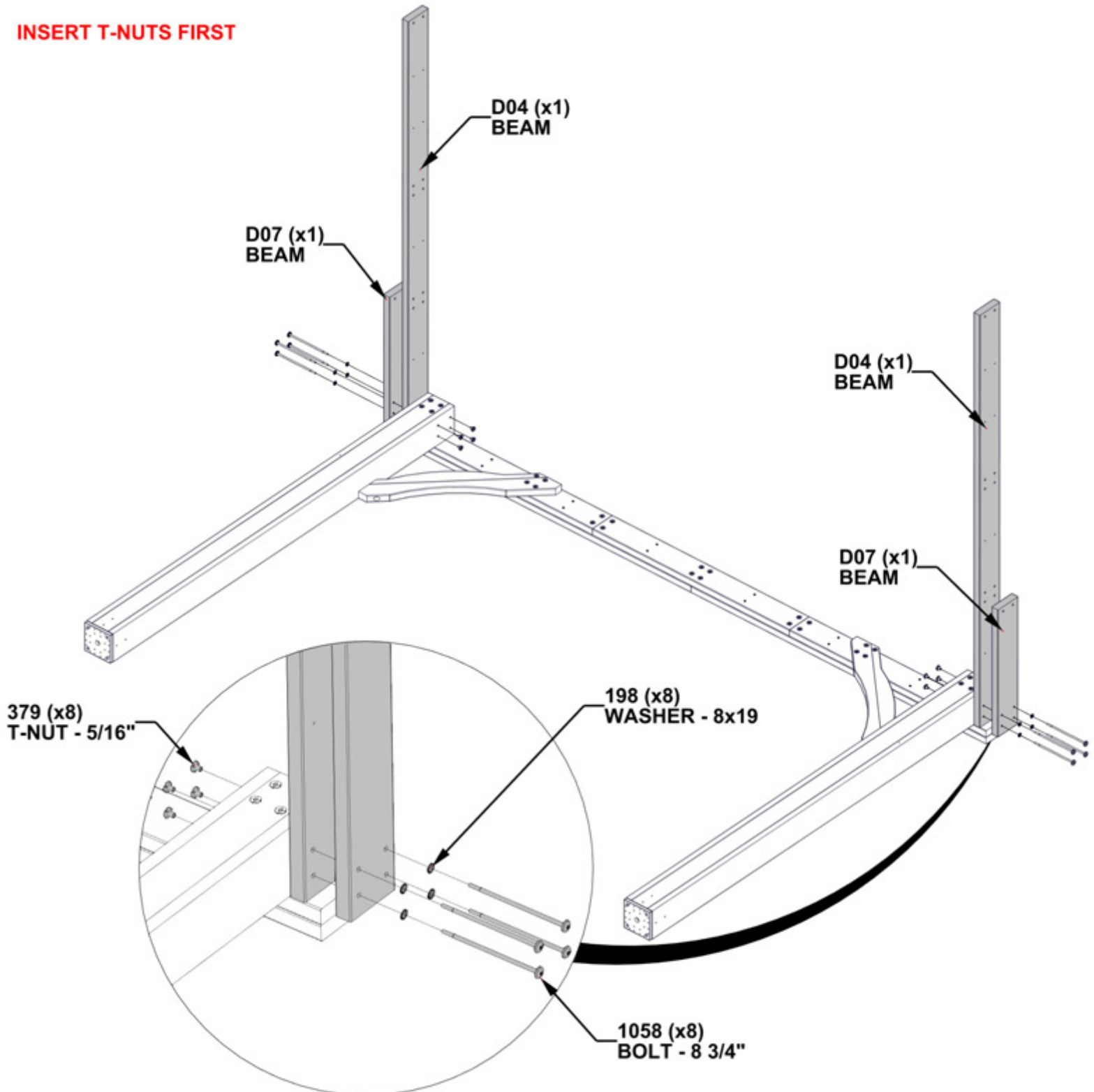

STEP 8 - 12FT BEAM ASSEMBLY

QTY	PART NUMBER	DESCRIPTION
2	H100792	LAG SCREW WH 1/4x3 BLK
2	H100405	WASHER LOCK EXT 6x15
4	H100513	BOLT WH 5/16x4 1/4 BLK
4	H100198	WASHER LOCK EXT 8x19
4	H100379	T-NUT 5/16 BLK

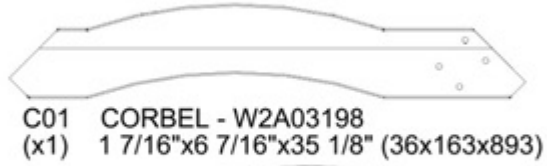

INSERT T-NUTS INTO CORBEL FIRST

TIPS:
INSERT BOLTS FIRST FOLLOWED BY LAG SCREWS.
TO AVOID WOOD SPLITTING, MAKE SURE LAG
SCREWS GO INTO PILOT HOLES.

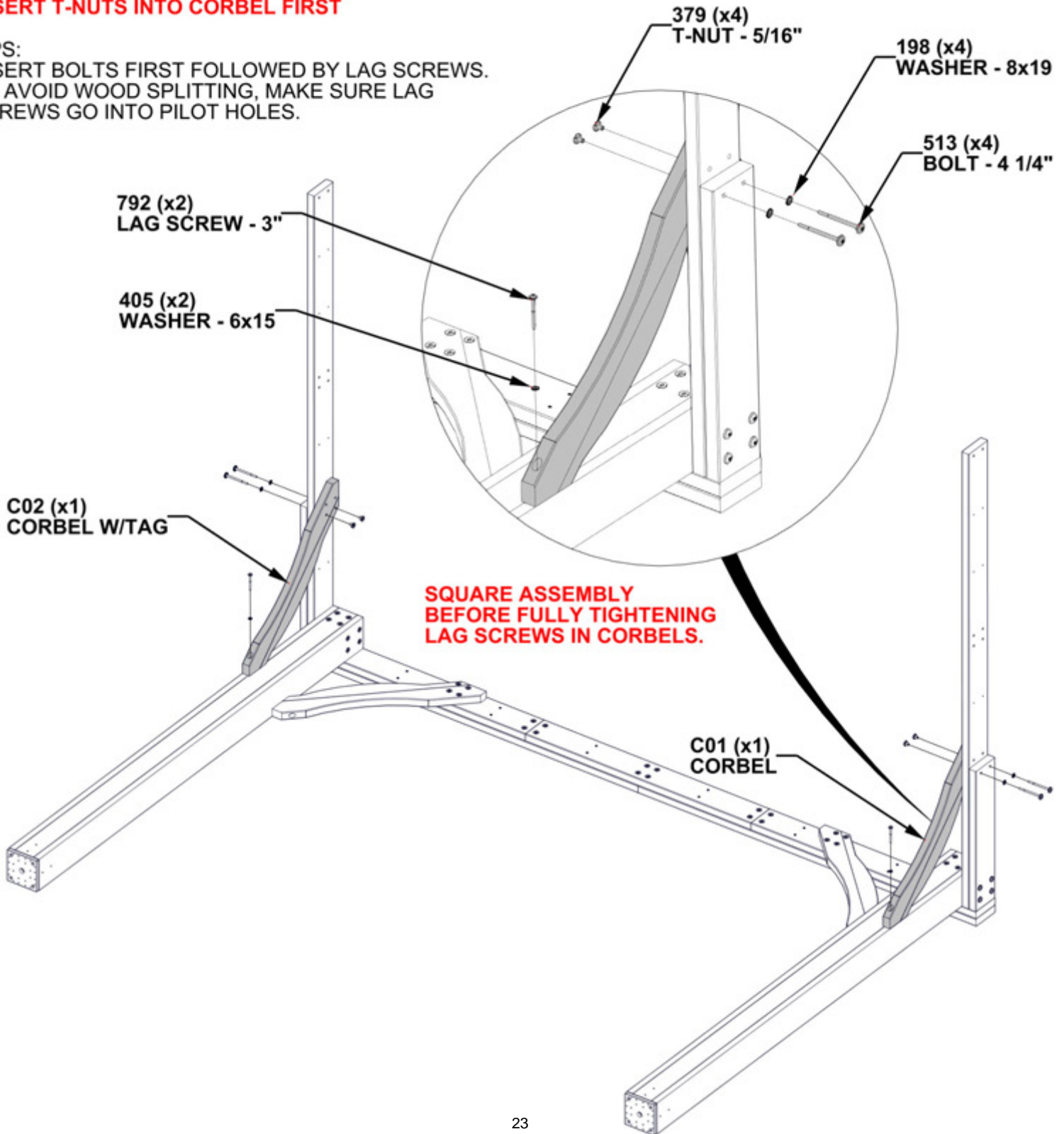

**SET 12FT ASSEMBLY TO THE SIDE
AND REPEAT STEPS 1 THROUGH 8.**

**NOTE: TWO C01 CORBELS WILL BE USED ON
STEP 8 FOR THE OTHER 12FT ASSEMBLY SIDE.**

STEP 9 - MIDDLE POST ASSEMBLY

QTY	PART NUMBER	DESCRIPTION
4	H100792	LAG SCREW WH 1/4x3 BLK
4	H100405	WASHER LOCK EXT 6x15
8	H101058	BOLT WH 5/16x8 3/4 BLK
8	H100513	BOLT WH 5/16x4 1/4 BLK
16	H100379	T-NUT 5/16 BLK
16	H100198	WASHER LOCK EXT 8x19

- P03 MIDDLE POST - W2A03711
(x2) 6"x6"x89 1/2" (152x152x2274)
- D06 BEAM - W4L17519
(x4) 1 7/16"x5 1/4"x84 15/16" (36x134x2157)
- D05 BEAM - W4L17518
(x2) 1 7/16"x5 1/4"x48 3/16" (36x134x1224)

- C01 CORBEL - W2A03198
(x4) 1 7/16"x6 7/16"x35 1/8" (36x163x893)

**INSERT T-NUTS FIRST
HAND TIGHTEN HARDWARE ONLY**

COMPLETE THIS STEP TWICE

TIPS:
INSERT BOLTS FIRST FOLLOWED BY LAG SCREWS.
TO AVOID WOOD SPLITTING, MAKE SURE LAG SCREWS GO INTO PILOT HOLES.

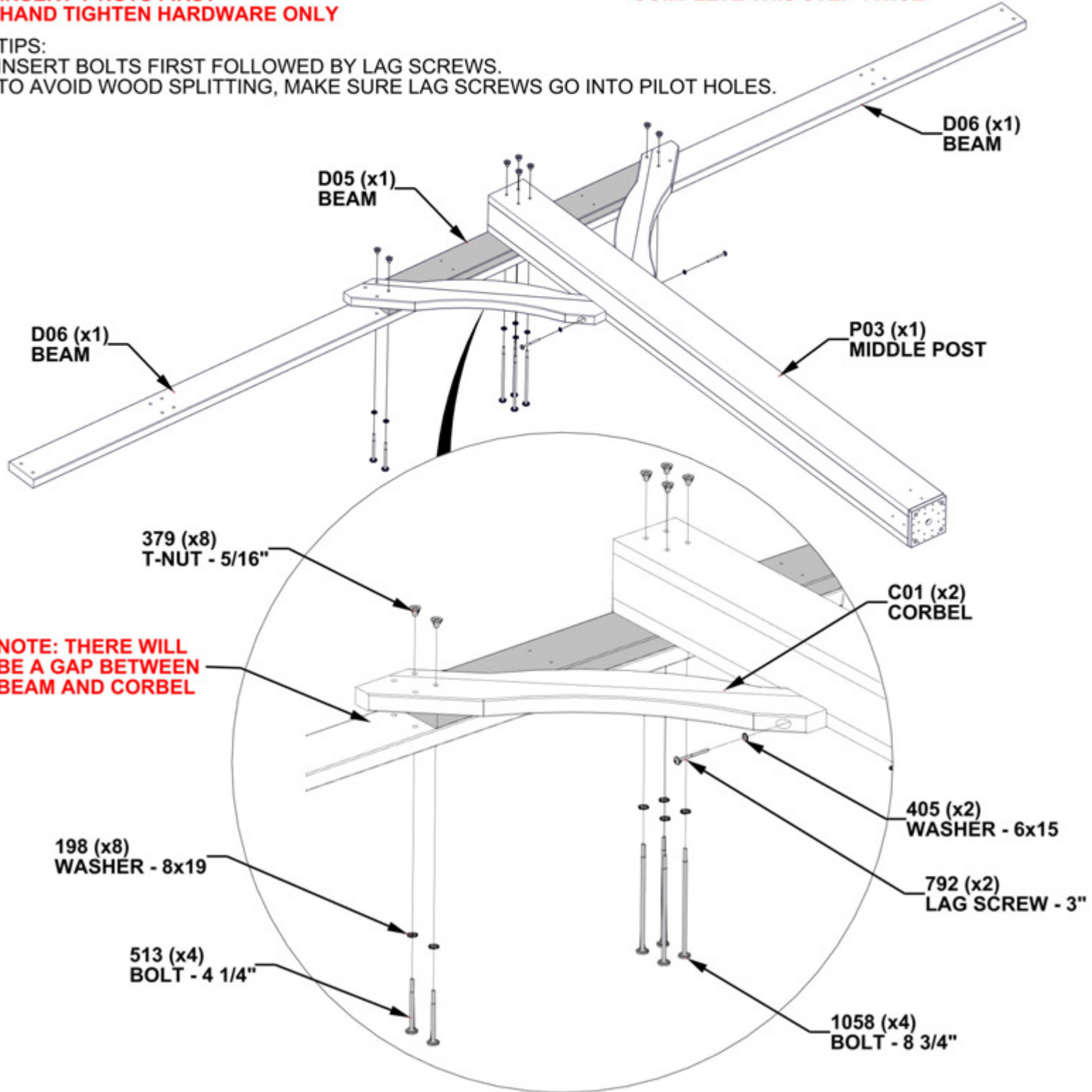

STEP 10 - GAZEBO ASSEMBLY

QTY	PART NUMBER	DESCRIPTION
4	H100195	BOLT WH 5/16x2 3/4 BLK
4	H100513	BOLT WH 5/16x4 1/4 BLK
8	H100198	WASHER LOCK EXT 8x19
8	H100379	T-NUT 5/16 BLK



**INSERT T-NUTS FIRST
HAND TIGHTEN HARDWARE ONLY**

**FOR THIS STEP IT IS HELPFUL TO HAVE THREE ADDITIONAL
PEOPLE TO HELP STAND UP ASSEMBLY AND ATTACH HARDWARE.**

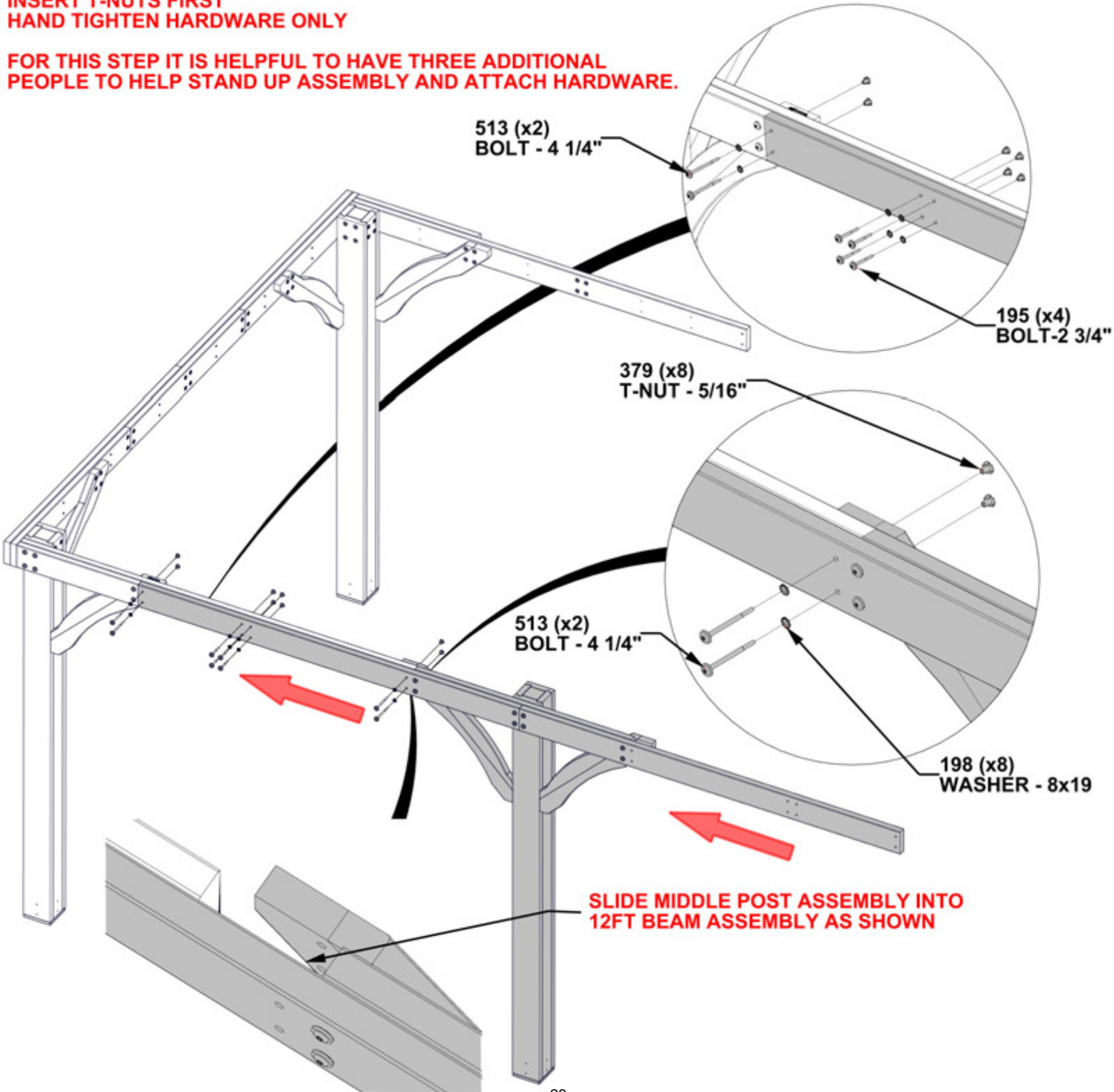

STEP 11 - GAZEBO ASSEMBLY

QTY	PART NUMBER	DESCRIPTION
4	H100513	BOLT WH 5/16x4 1/4 BLK
4	H100195	BOLT WH 5/16x2 3/4 BLK
8	H100198	WASHER LOCK EXT 8x19
8	H100379	T-NUT 5/16 BLK



MIDDLE POST ASSEMBLY

**INSERT T-NUTS FIRST
HAND TIGHTEN HARDWARE ONLY**

**FOR THIS STEP IT IS HELPFUL TO HAVE THREE ADDITIONAL
PEOPLE TO HELP STAND UP ASSEMBLY AND ATTACH HARDWARE.**

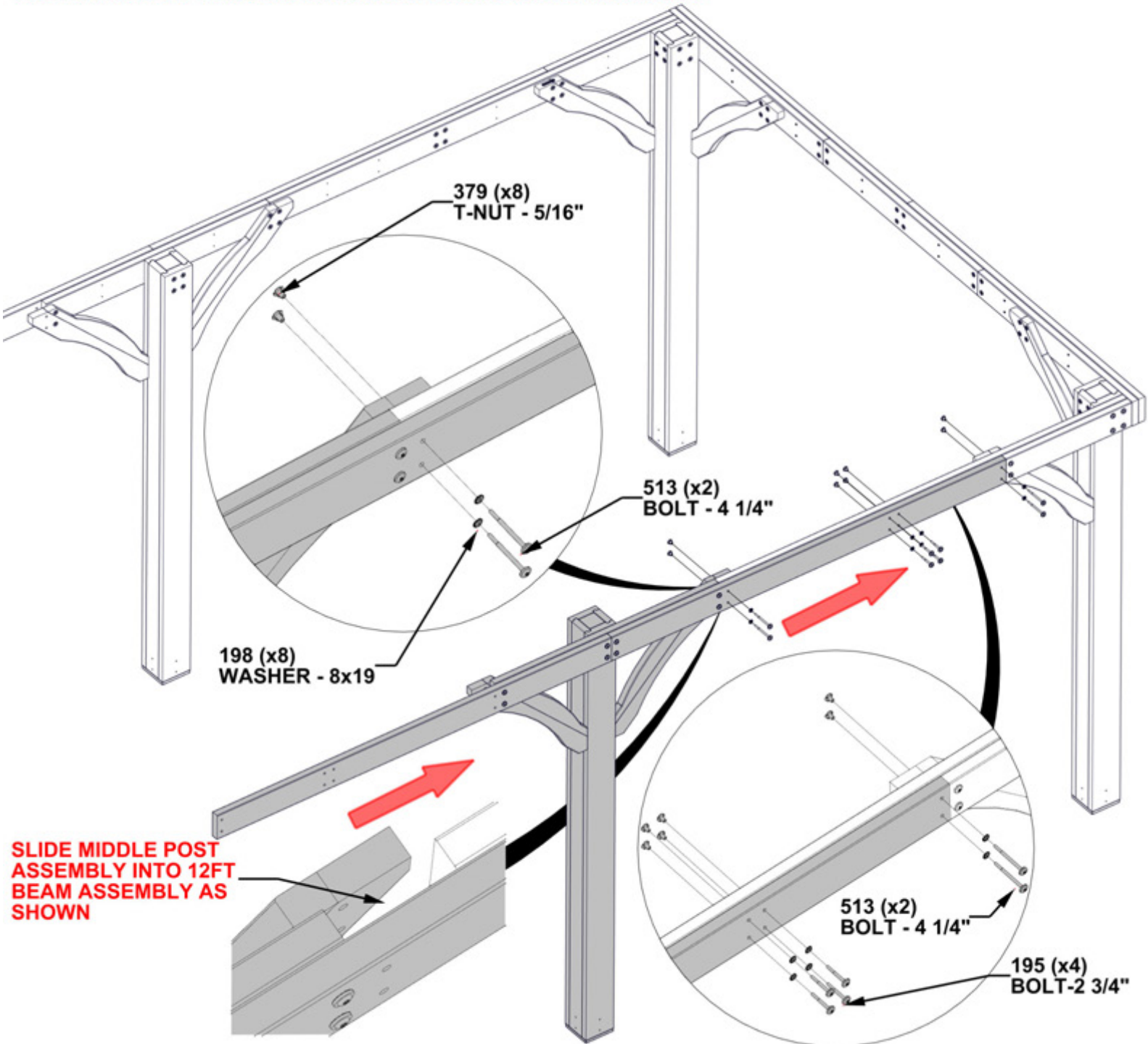

STEP 12 - GAZEBO ASSEMBLY

QTY	PART NUMBER	DESCRIPTION
8	H100513	BOLT WH 5/16x4 1/4 BLK
8	H100195	BOLT WH 5/16x2 3/4 BLK
16	H100379	T-NUT 5/16 BLK
16	H100198	WASHER LOCK EXT 8x19



12FT BEAM ASSEMBLY

**INSERT T-NUTS FIRST
HAND TIGHTEN HARDWARE ONLY**

**FOR THIS STEP IT IS HELPFUL TO HAVE THREE ADDITIONAL
PEOPLE TO HELP STAND UP ASSEMBLY AND ATTACH HARDWARE.**

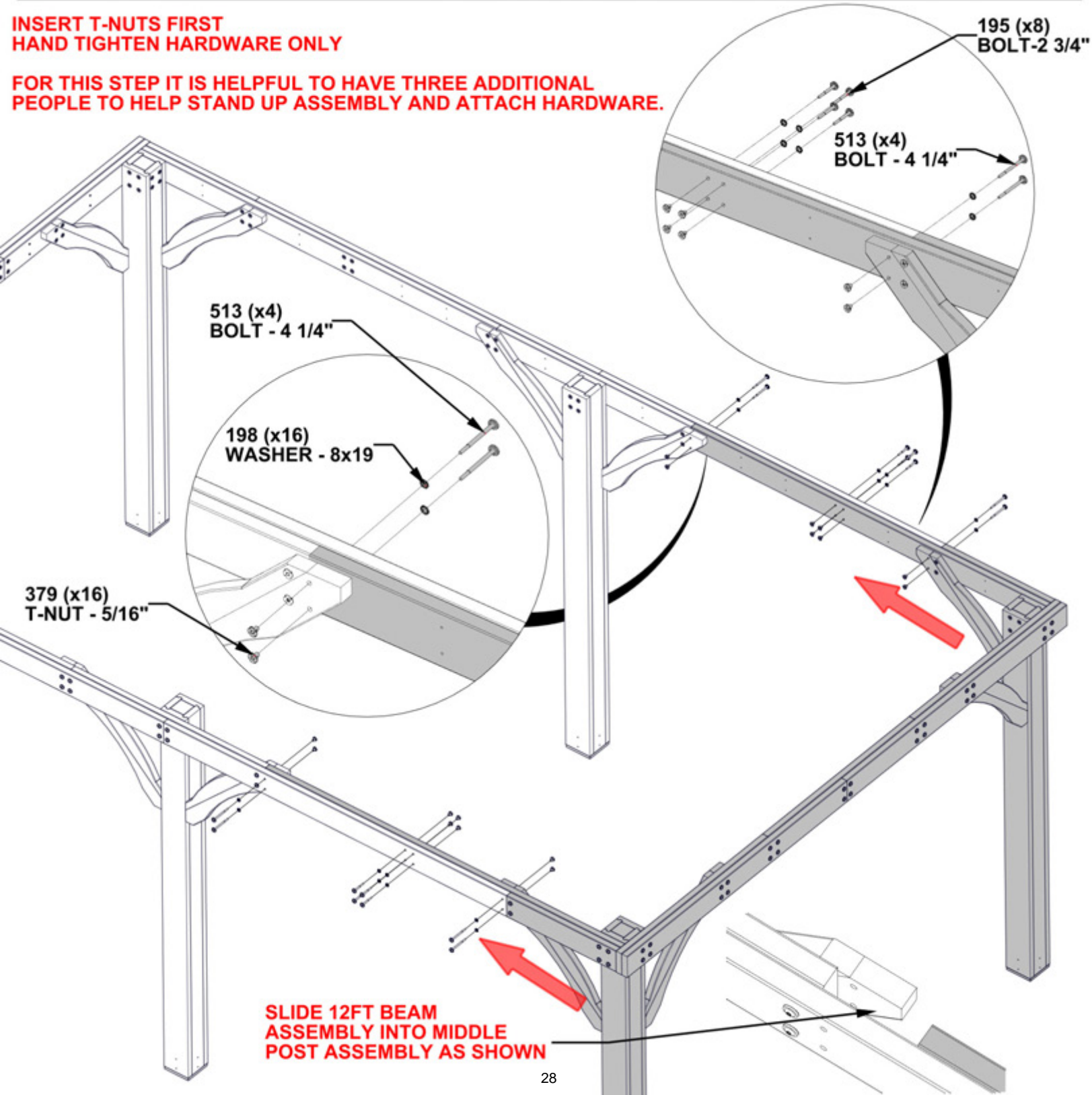

**SLIDE 12FT BEAM
ASSEMBLY INTO MIDDLE
POST ASSEMBLY AS SHOWN**

STEP 13 - SQUARE THE ASSEMBLY

**CRITICAL: SQUARE GAZEBO BEFORE PROCEEDING TO NEXT STEPS.
ONCE SQUARE, TIGHTEN ALL HARDWARE.**

MEASUREMENTS TAKEN FROM INSIDE OF POST TO INSIDE OF POST.

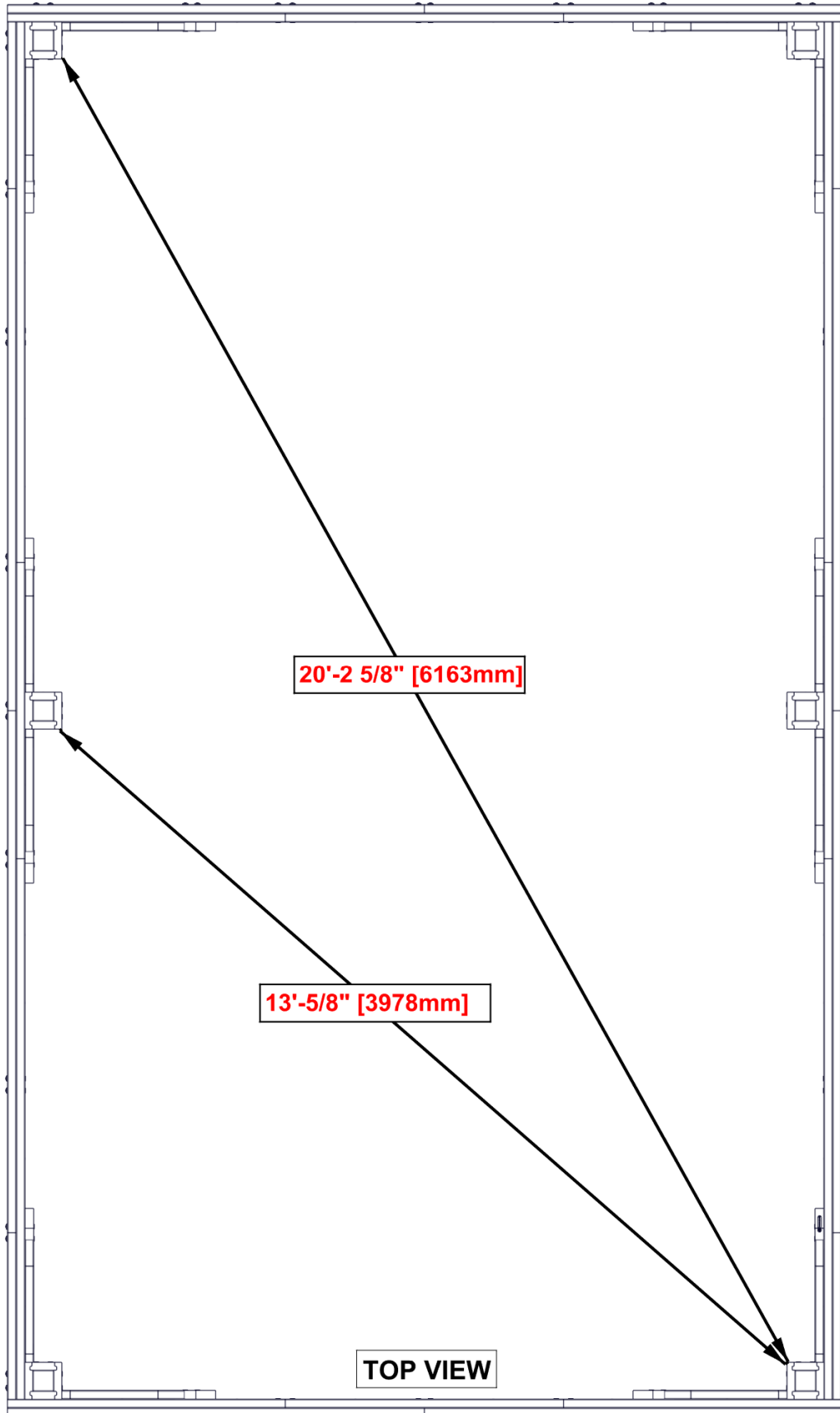

STEP 14 - GAZEBO ASSEMBLY

QTY	PART NUMBER	DESCRIPTION
40	H100483	SCREW PFH 8x2 1/4 BLK

**INSTALL SCREWS IN PRE-DRILLED HOLES
IN BEAMS ON BOTH SIDES OF GAZEBO**

**483 (x40)
SCREW - 2 1/4"**

**PRE-DRILLED
HOLES**

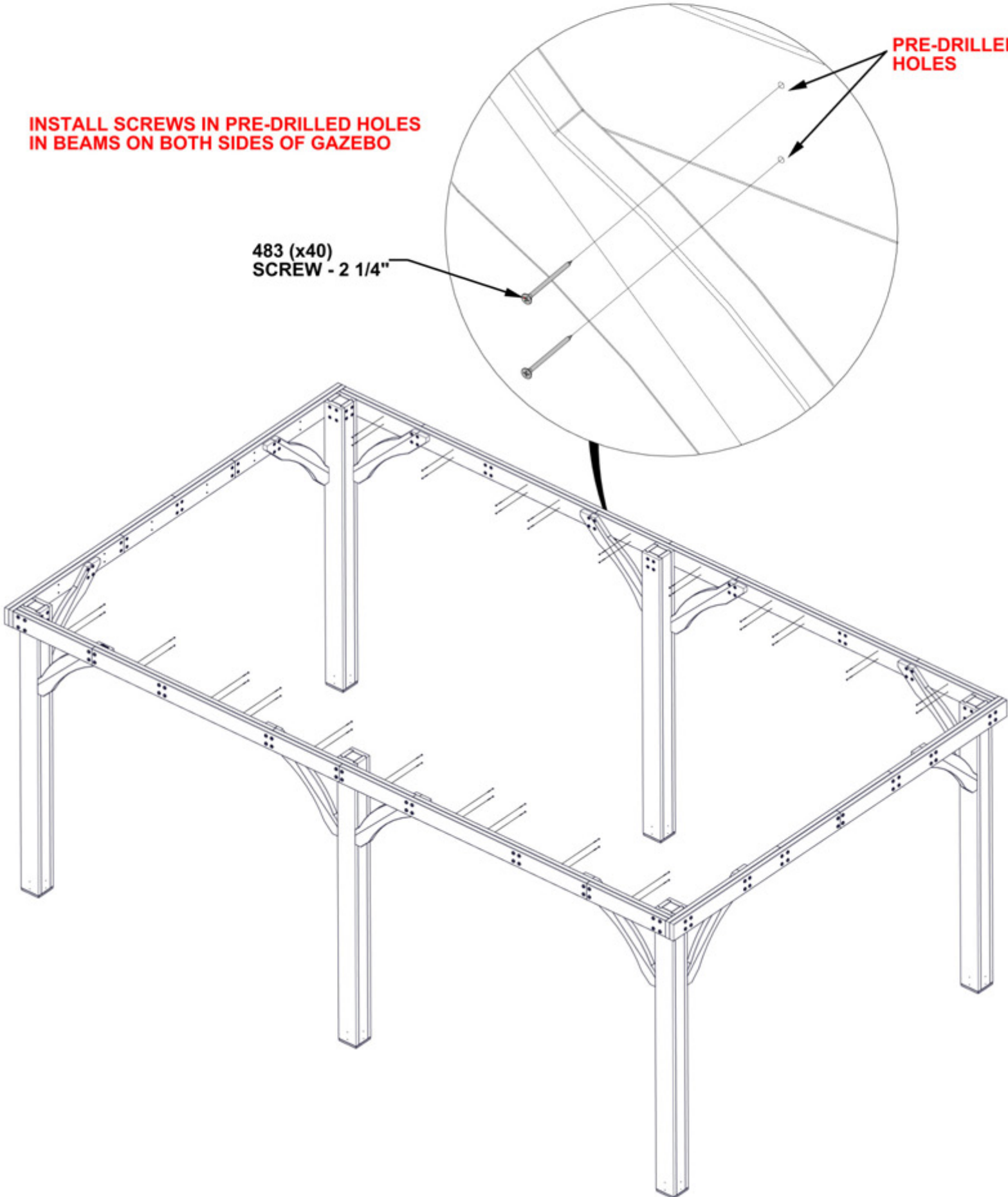

STEP 15 - ROOF SUPPORT ASSEMBLY

QTY	PART NUMBER	DESCRIPTION
16	H100460	LAG SCREW WH 1/4x1 BLK

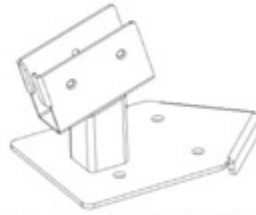

A4M01234 POST CLIP ASSEMBLY (x4)

DO NOT OVERTIGHTEN
REPEAT ON ALL FOUR CORNER POST

460 (x4)
LAG SCREW - 1"

1234 (x4)
POST CLIP ASSEMBLY

MAKE SURE POST CLIPS ARE FLUSH WITH POST BEFORE ATTACHING LAG SCREWS.

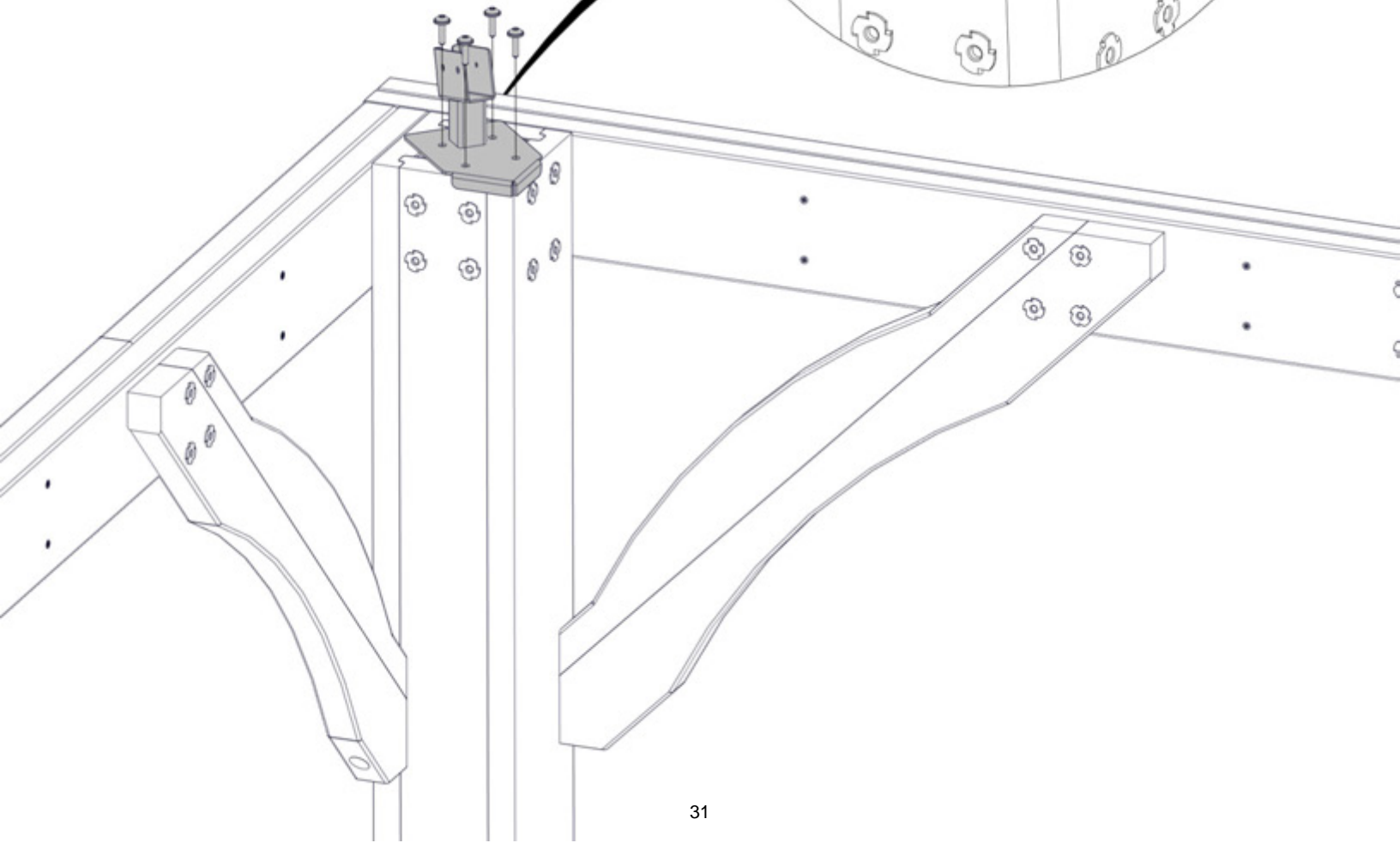
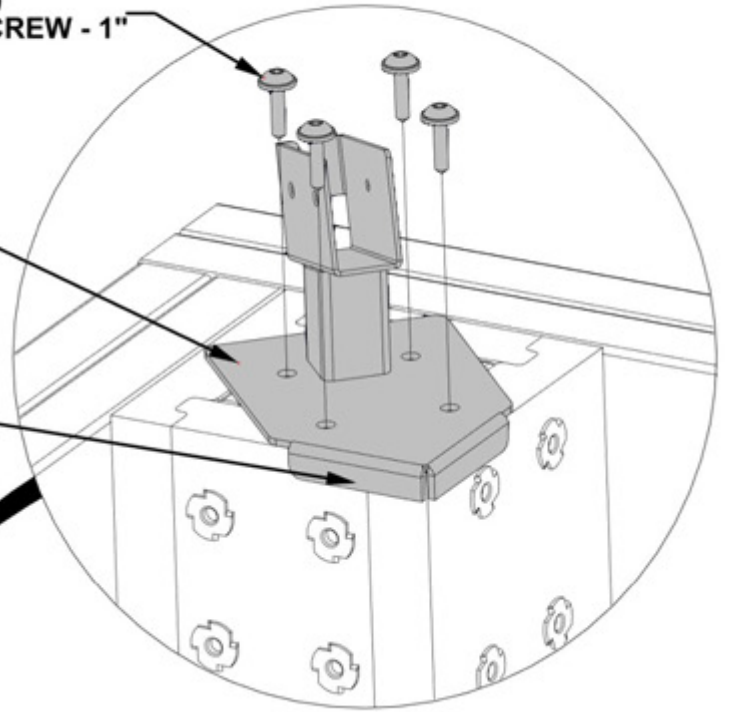

STEP 16 - ROOF SUPPORT ASSEMBLY

QTY	PART NUMBER	DESCRIPTION
8	H100460	LAG SCREW WH 1/4x1 BLK

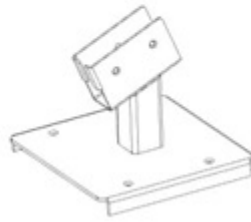

A4M01894 MIDDLE POST CLIP ASSEMBLY
(x2)

DO NOT OVERTIGHTEN
REPEAT ON BOTH MIDDLE POSTS

**MAKE SURE POST CLIPS ARE
FLUSH WITH POST BEFORE
ATTACHING LAG SCREWS.**

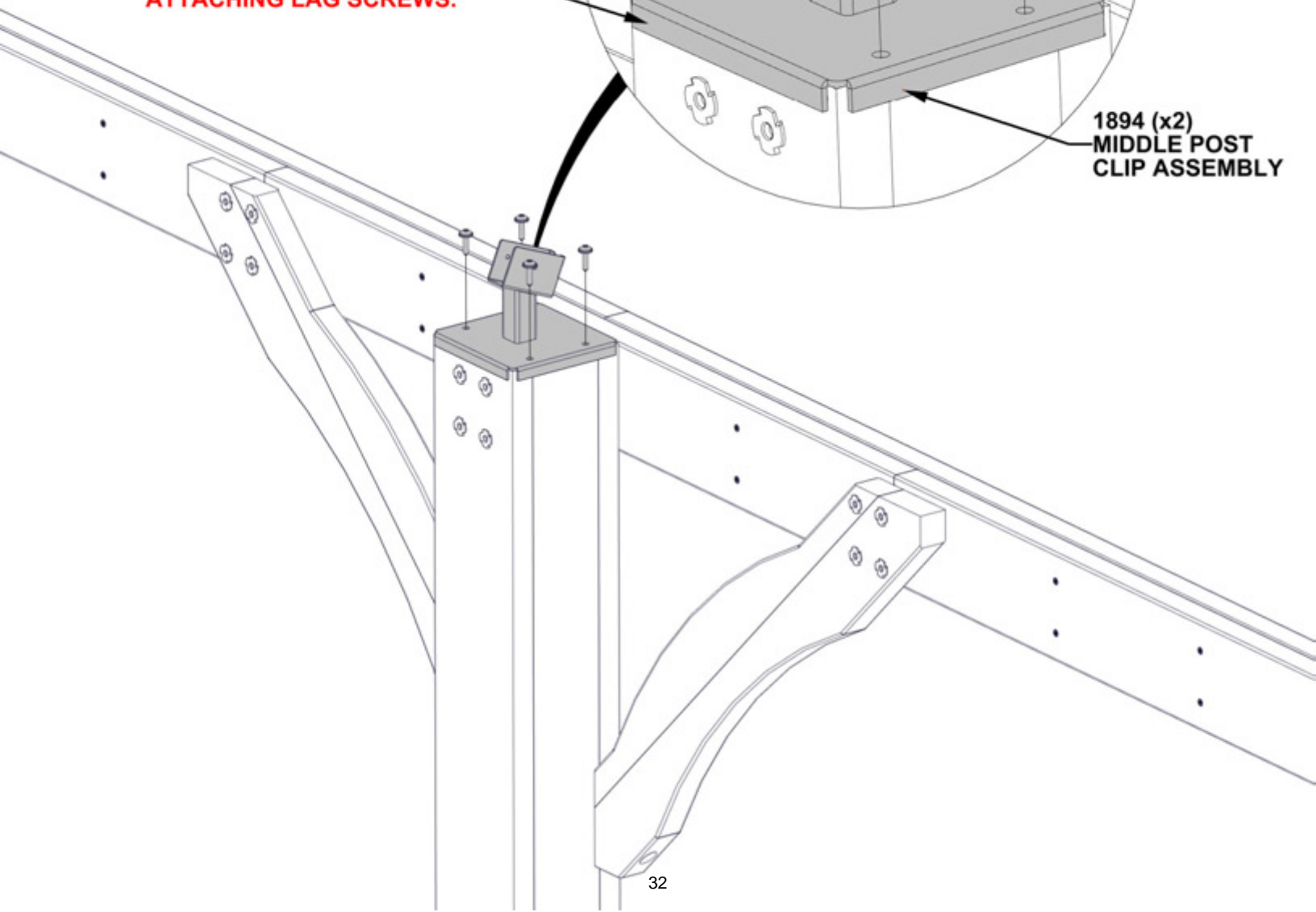
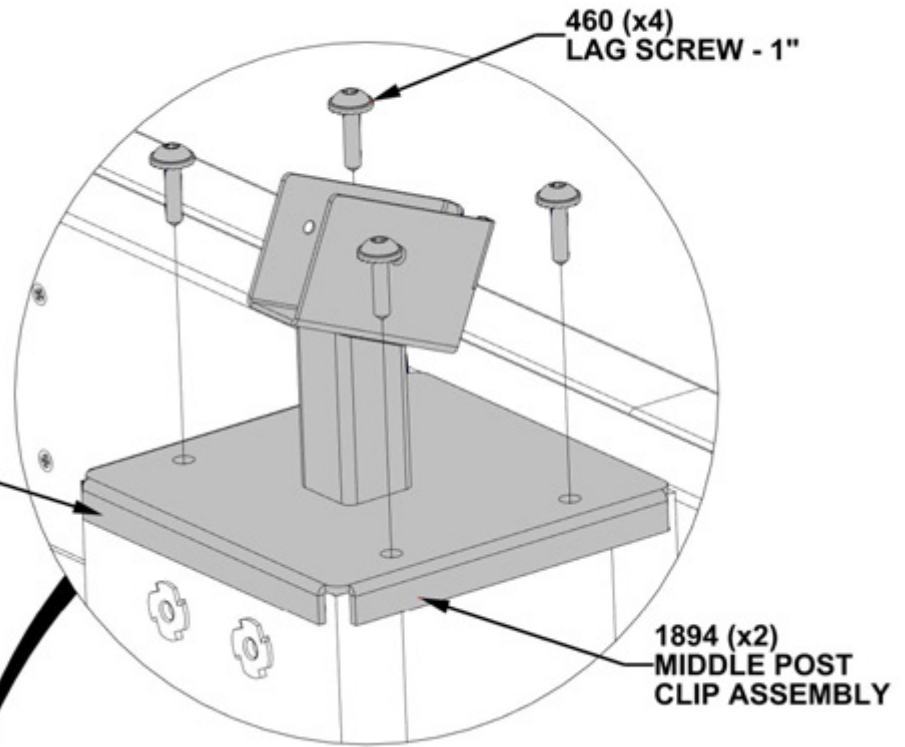

STEP 17 - ROOF SUPPORT ASSEMBLY

QTY	PART NUMBER	DESCRIPTION
28	H100382	SCREW PFH 8x1 3/4 BLK



H03 RIDGE - W4L17523
(x2) 15/16"x3 3/8"x32 5/16" (24x86x821)



H04 RIDGE - W4L17524
(x2) 15/16"x3 3/8"x63 11/16" (24x86x1618)

FLUSH ENDS AND ALL EDGES BEFORE INSERTING SCREWS

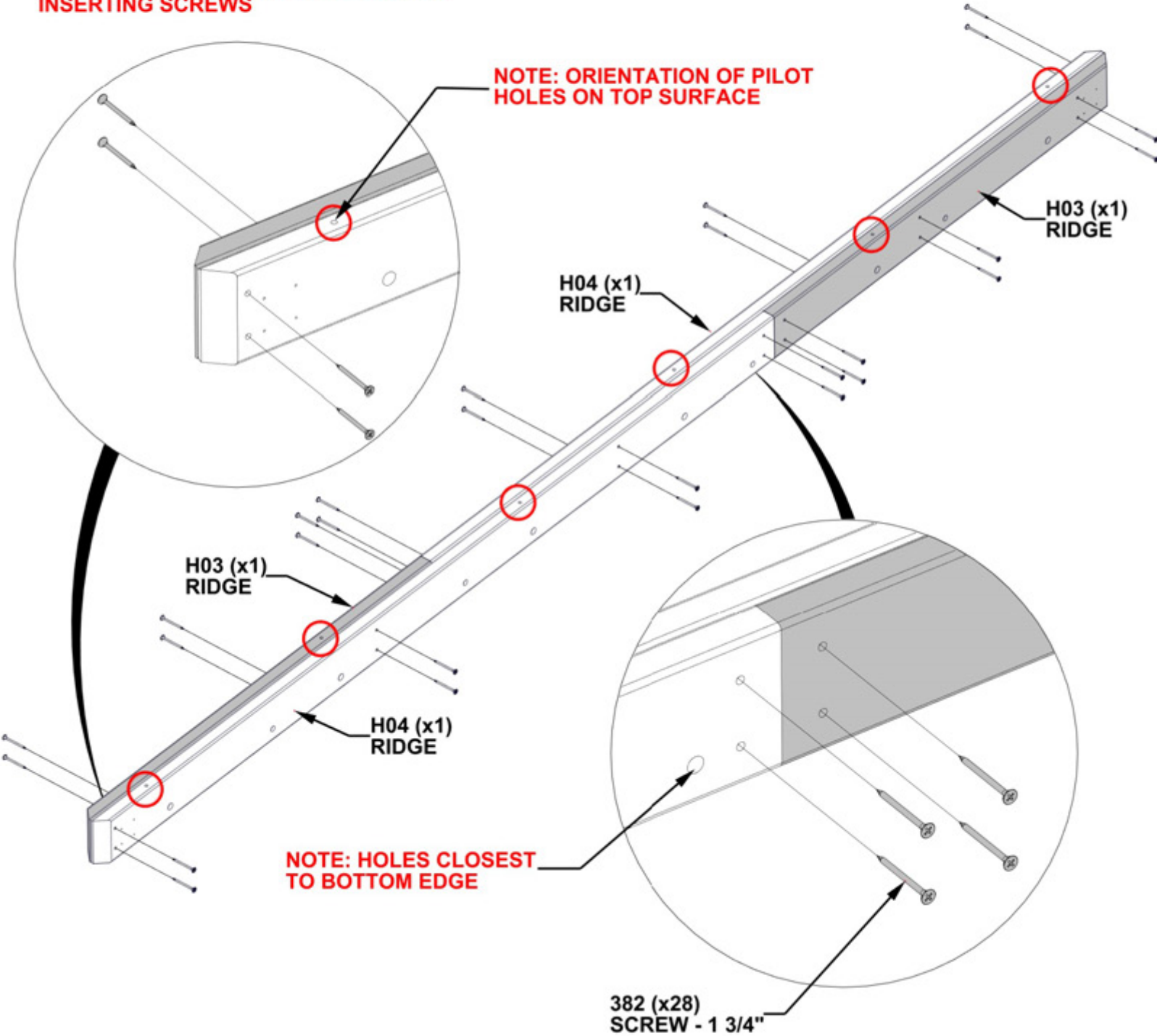

STEP 18 - ROOF SUPPORT ASSEMBLY

QTY	PART NUMBER	DESCRIPTION
4	H100379	TNUT-5/16" BLK
16	H100385	SCREW PFH 8x1 BLK

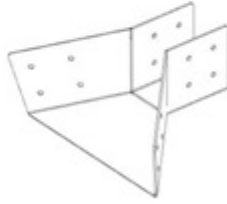

A4M01895 PANEL SUPPORT BRACKET
(x2)

INSERT T-NUTS FIRST

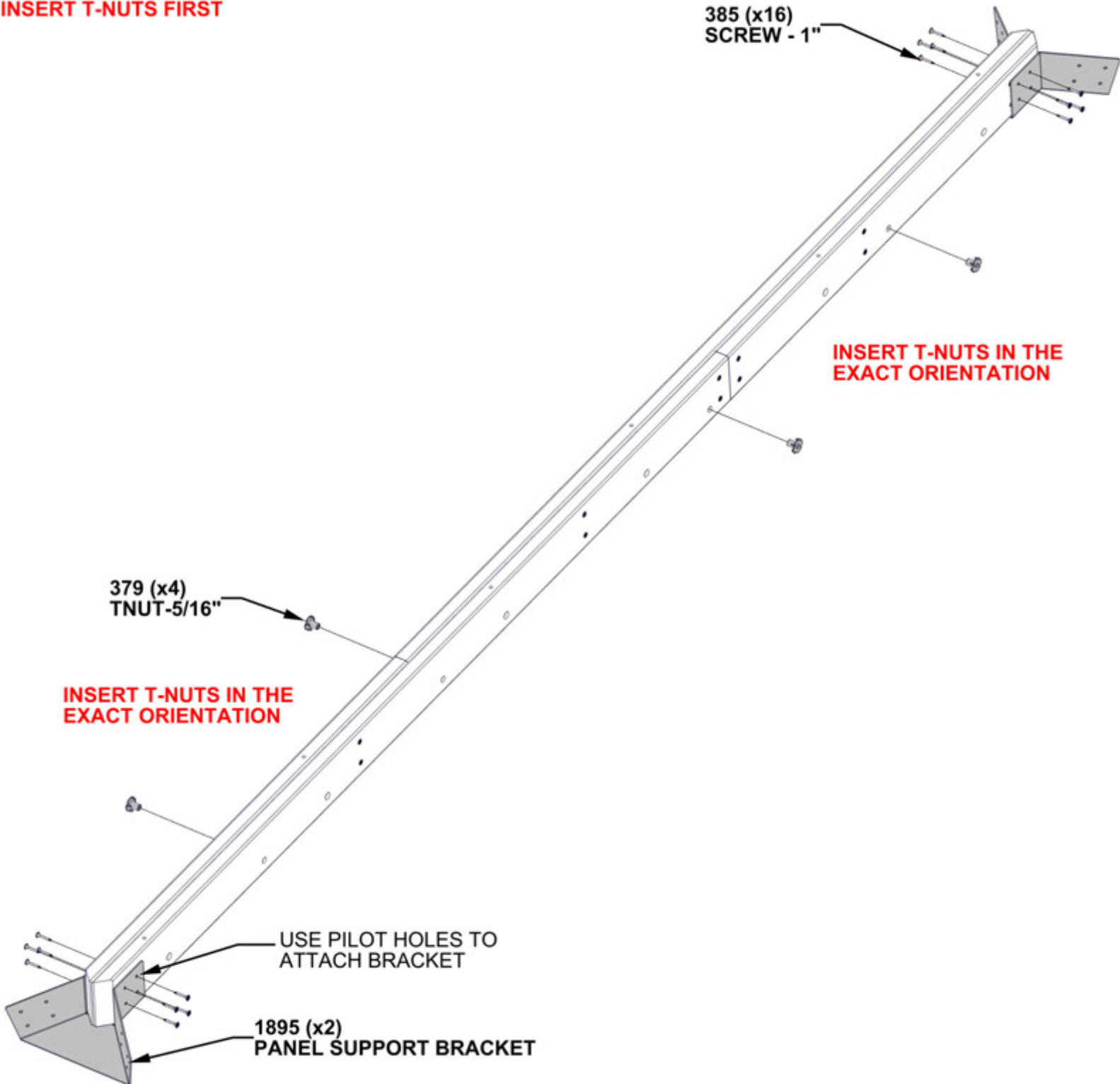

STEP 19 - ROOF SUPPORT ASSEMBLY

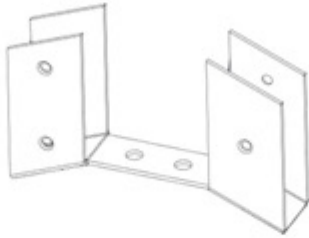

A4M01902 RAFTER HANGER
(x1)

QTY	PART NUMBER	DESCRIPTION
2	H100403	LAG SCREW WH 1/4x1 1/2 BLK

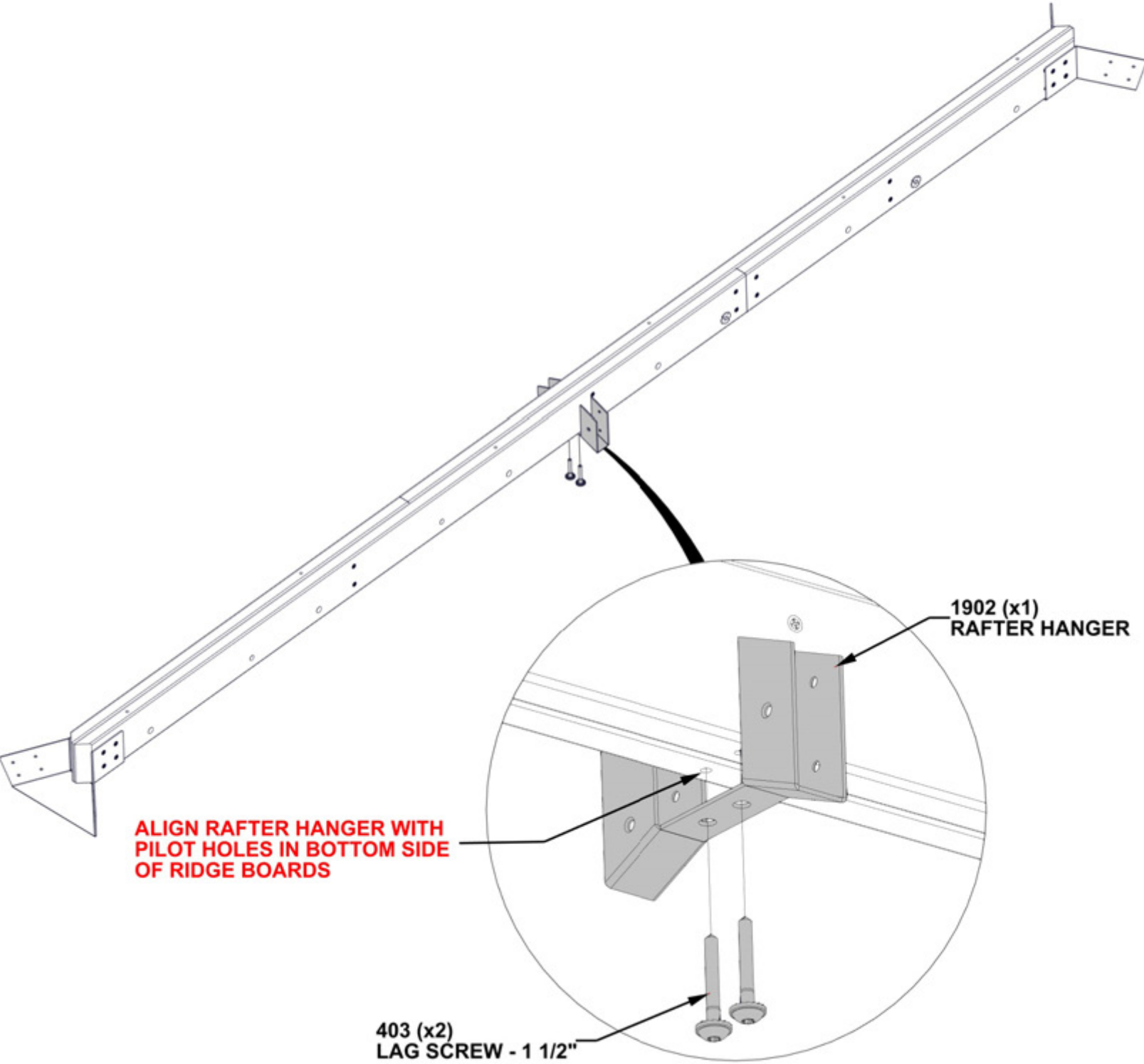

STEP 20 - ROOF SUPPORT ASSEMBLY

QTY	PART NUMBER	DESCRIPTION
2	H100379	TNUT-5/16" BLK
24	H100385	SCREW PFH 8x1 BLK



H02 RAFTER - W4L17522
(x2) 15/16"x3 3/8"x39 3/8" (24x86x1000)



A4M01237 ROOF SUPPORT SPLICE CLIP
(x2)



H01 RAFTER - W4L17521
(x2) 15/16"x3 3/8"x54 1/8" (24x86x1374)

INSERT T-NUTS FIRST
REPEAT THIS STEP TWICE

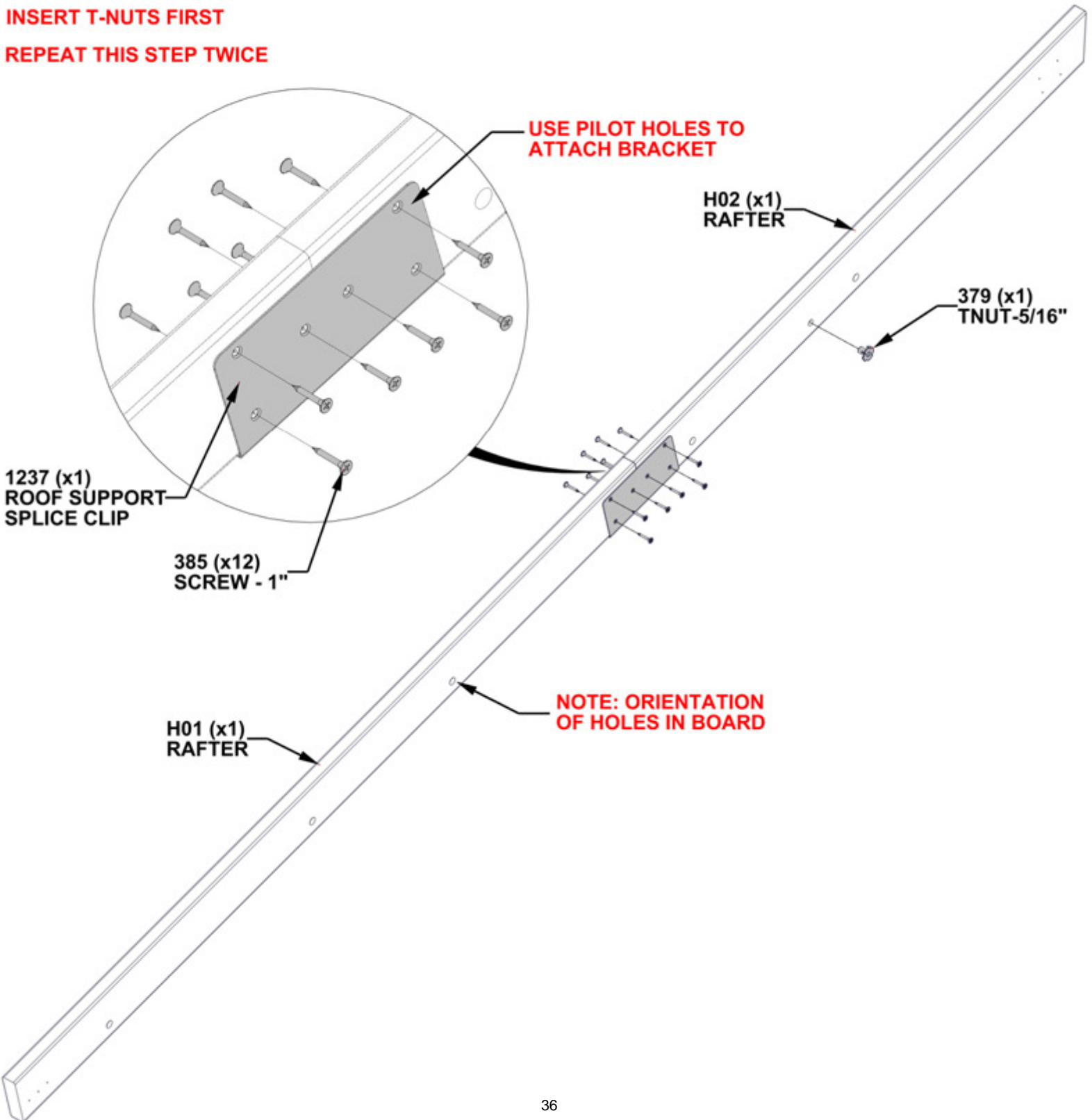

STEP 21 - ROOF SUPPORT ASSEMBLY

QTY	PART NUMBER	DESCRIPTION
2	H100379	TNUT-5/16" BLK
24	H100385	SCREW PFH 8x1 BLK



H02 RAFTER - W4L17522
(x2) 15/16"x3 3/8"x39 3/8" (24x86x1000)



A4M01237 ROOF SUPPORT SPLICE CLIP
(x2)



H01 RAFTER - W4L17521
(x2) 15/16"x3 3/8"x54 1/8" (24x86x1374)

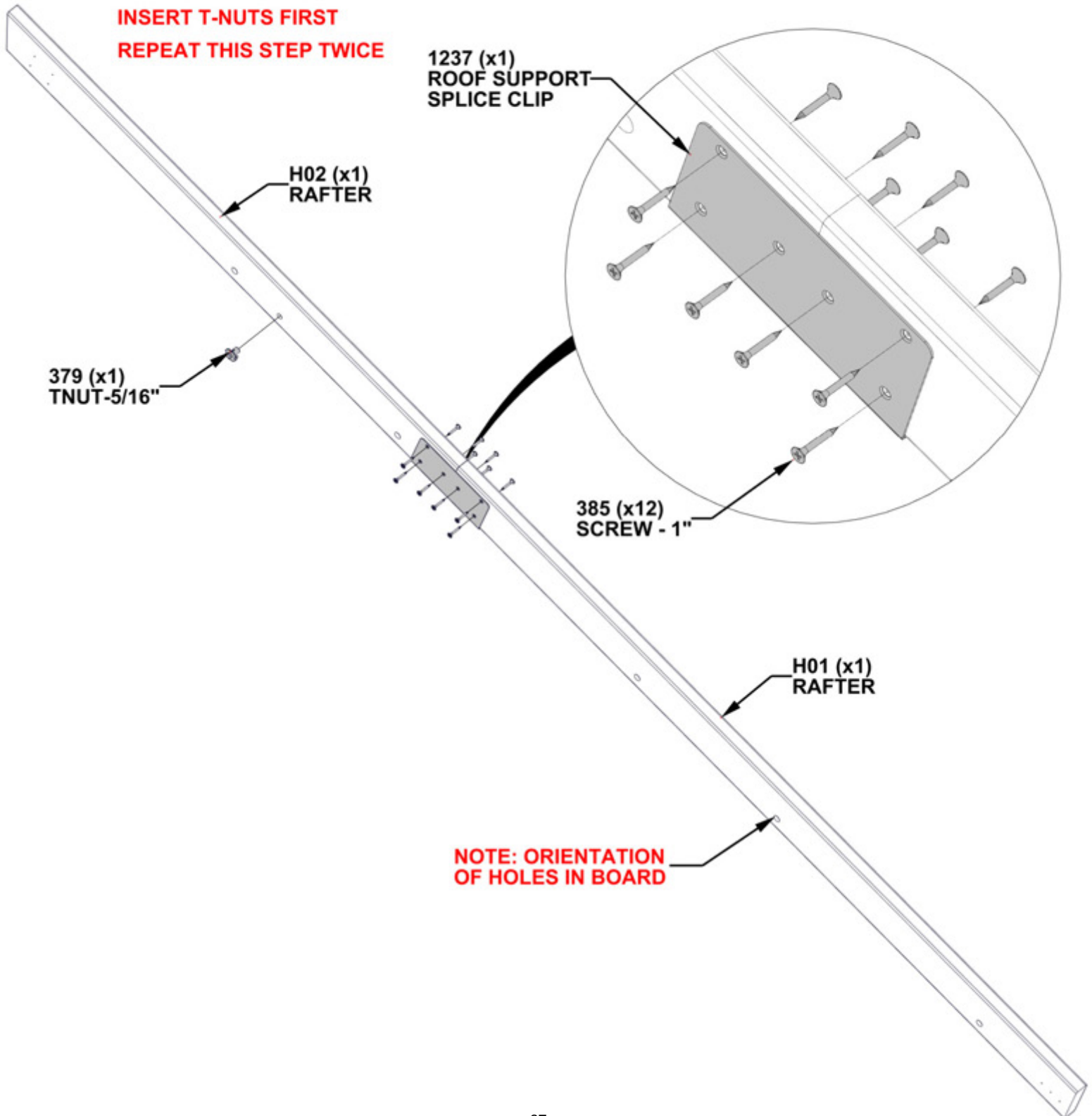

STEP 22 - ROOF SUPPORT ASSEMBLY

QTY	PART NUMBER	DESCRIPTION
16	H100385	SCREW PFH 8x1 BLK

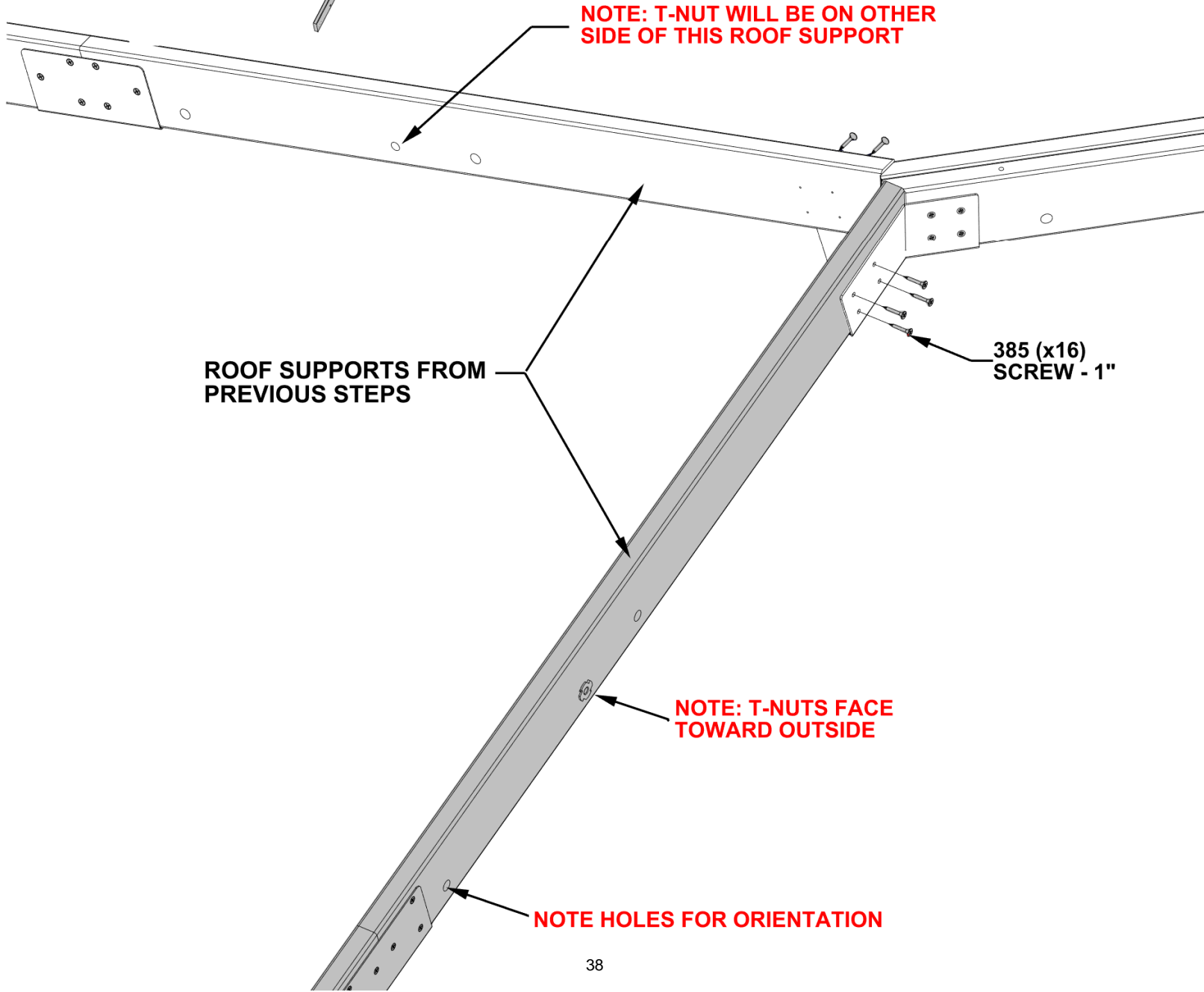
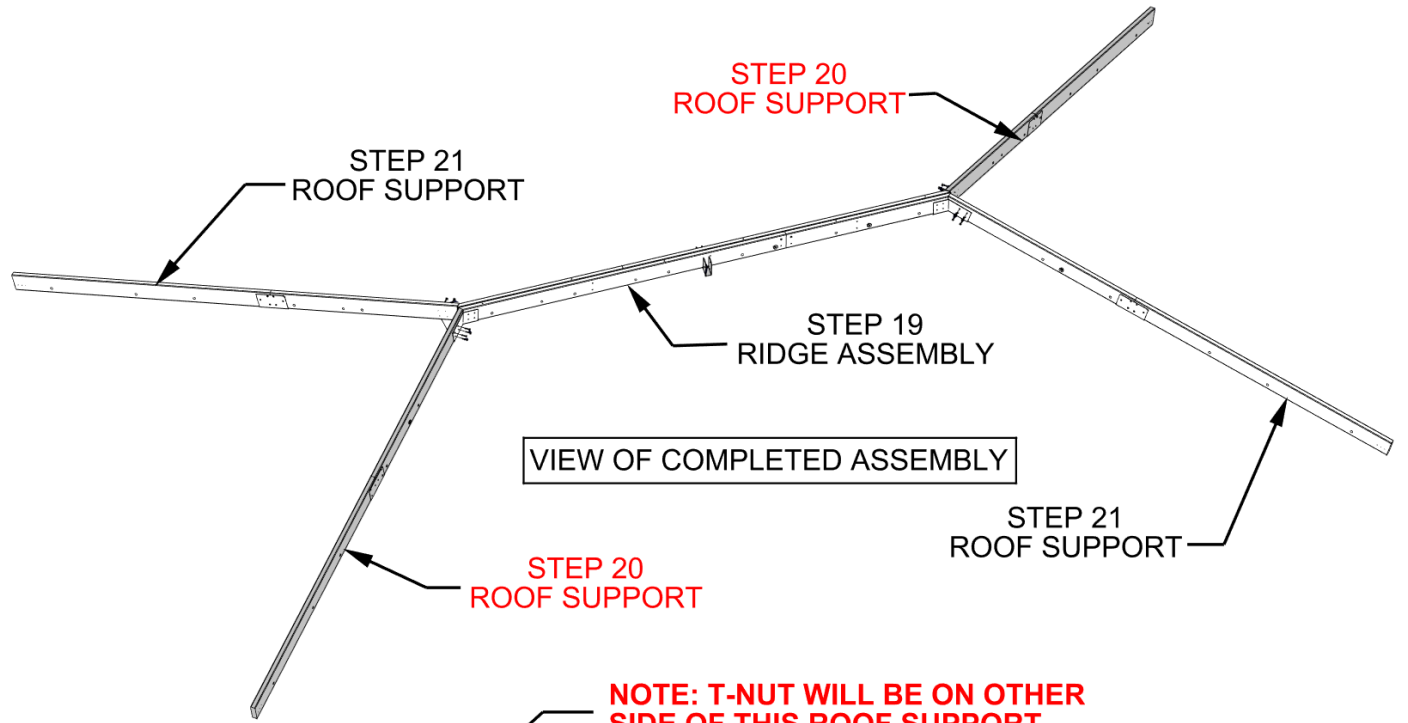

STEP 23A - ROOF SUPPORT ASSEMBLY

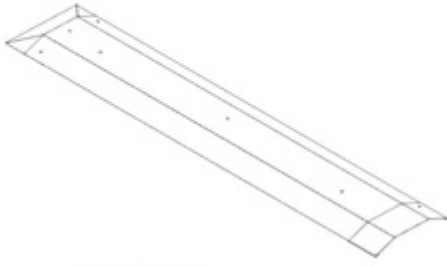

A4M02823 RIDGE PEAK CAP
(x1)

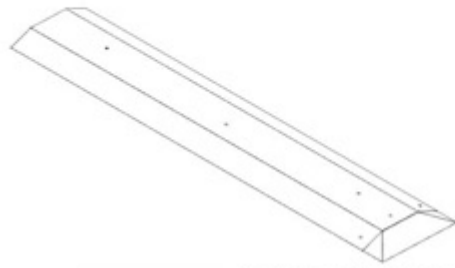

A4M02324 RIDGE PEAK CAP
(x1)

TIPS:
REMOVE PROTECTIVE BLUE FILM BEFORE ASSEMBLY

WARNING: GLOVES ARE RECOMMENDED WHEN HANDLING STEEL ROOF PIECES

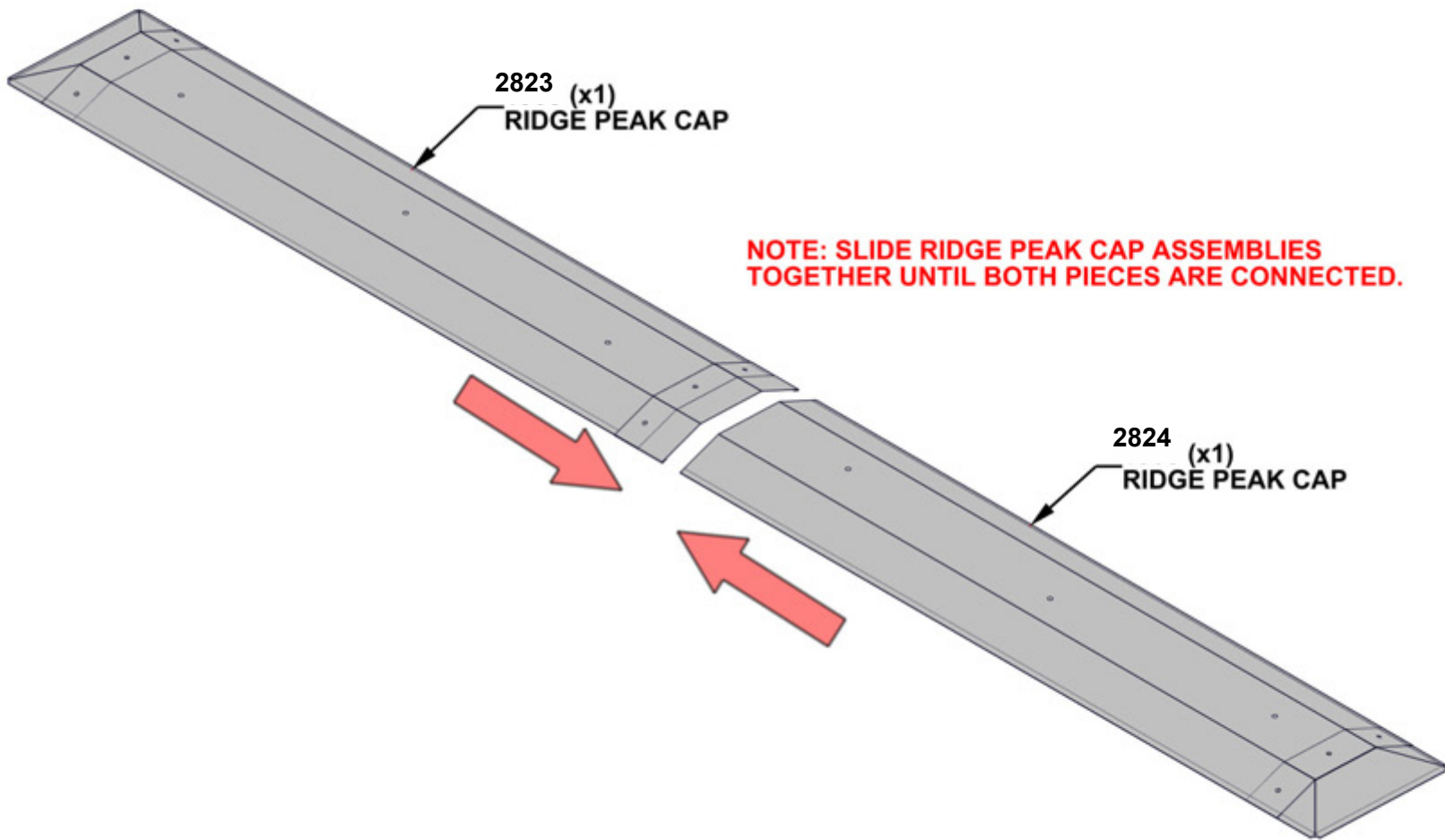

STEP 23B - ROOF SUPPORT ASSEMBLY

QTY	PART NUMBER	DESCRIPTION
6	H100792	LAG SCREW WH 1/4x3 BLK
6	H101034	WEATHER PROOFING WASHER



RIDGE PEAK CAP ASSEMBLY FROM PREVIOUS STEP



A4M01205 METAL SPACER (x6)

TIPS:
REMOVE PROTECTIVE FILM BEFORE ASSEMBLY

WARNING: GLOVES ARE RECOMMENDED WHEN HANDLING STEEL ROOF PIECES

LIFT RIDGE PEAK CAP ASSEMBLY FROM THE MIDDLE TO PREVENT FROM BENDING

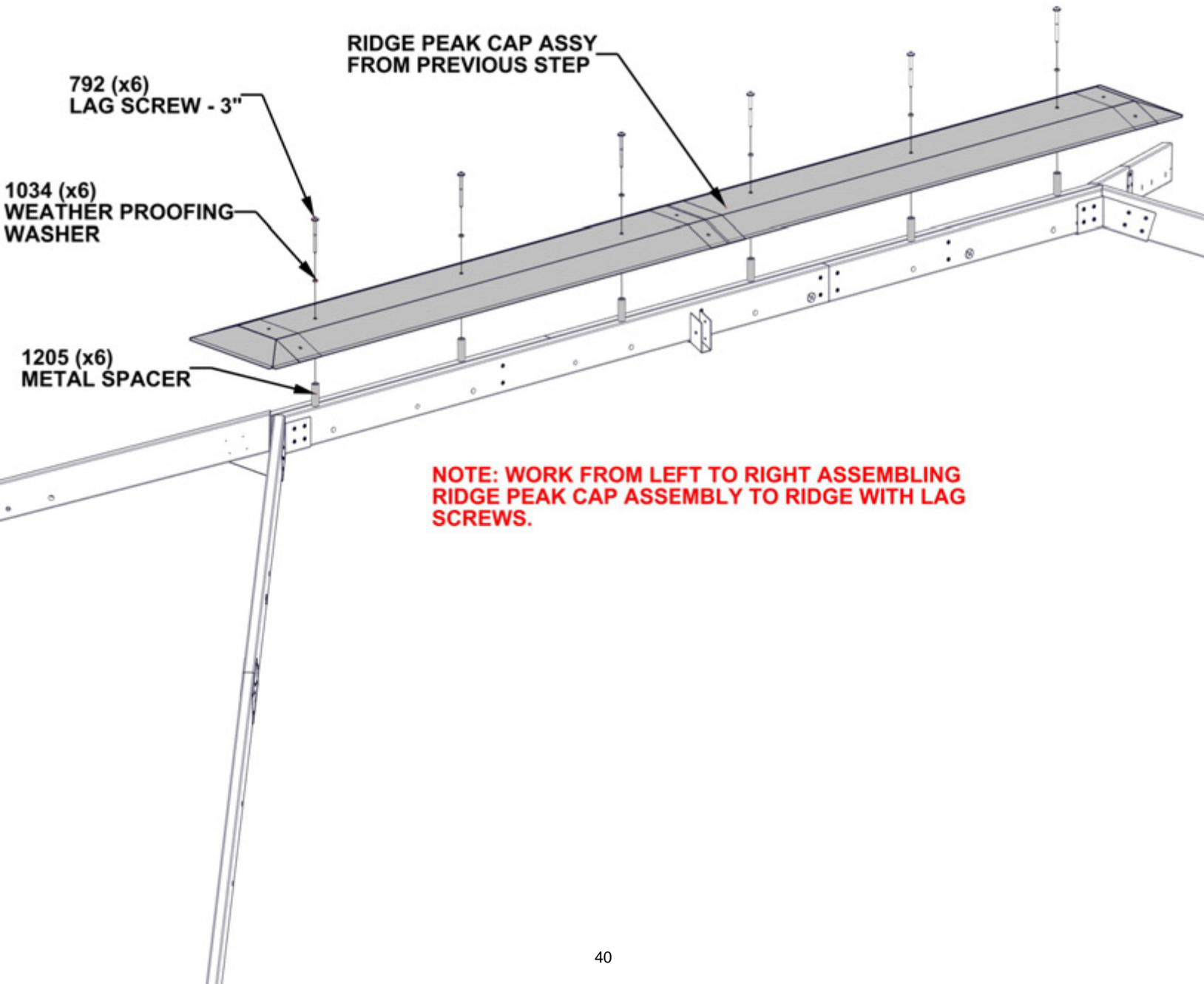

NOTE: WORK FROM LEFT TO RIGHT ASSEMBLING RIDGE PEAK CAP ASSEMBLY TO RIDGE WITH LAG SCREWS.

STEP 24 - SUPPORT ASSEMBLY

TIPS:
THREE ADDITIONAL PEOPLE ARE HELPFUL FOR THIS STEP.
POSITION A PERSON ON A LADDER IN THE CENTER OF THE BASE.
LIFT ROOF SUPPORT UP AND OVER THE 20FT SIDE AND INSERT INTO CORNER POST CLIPS.

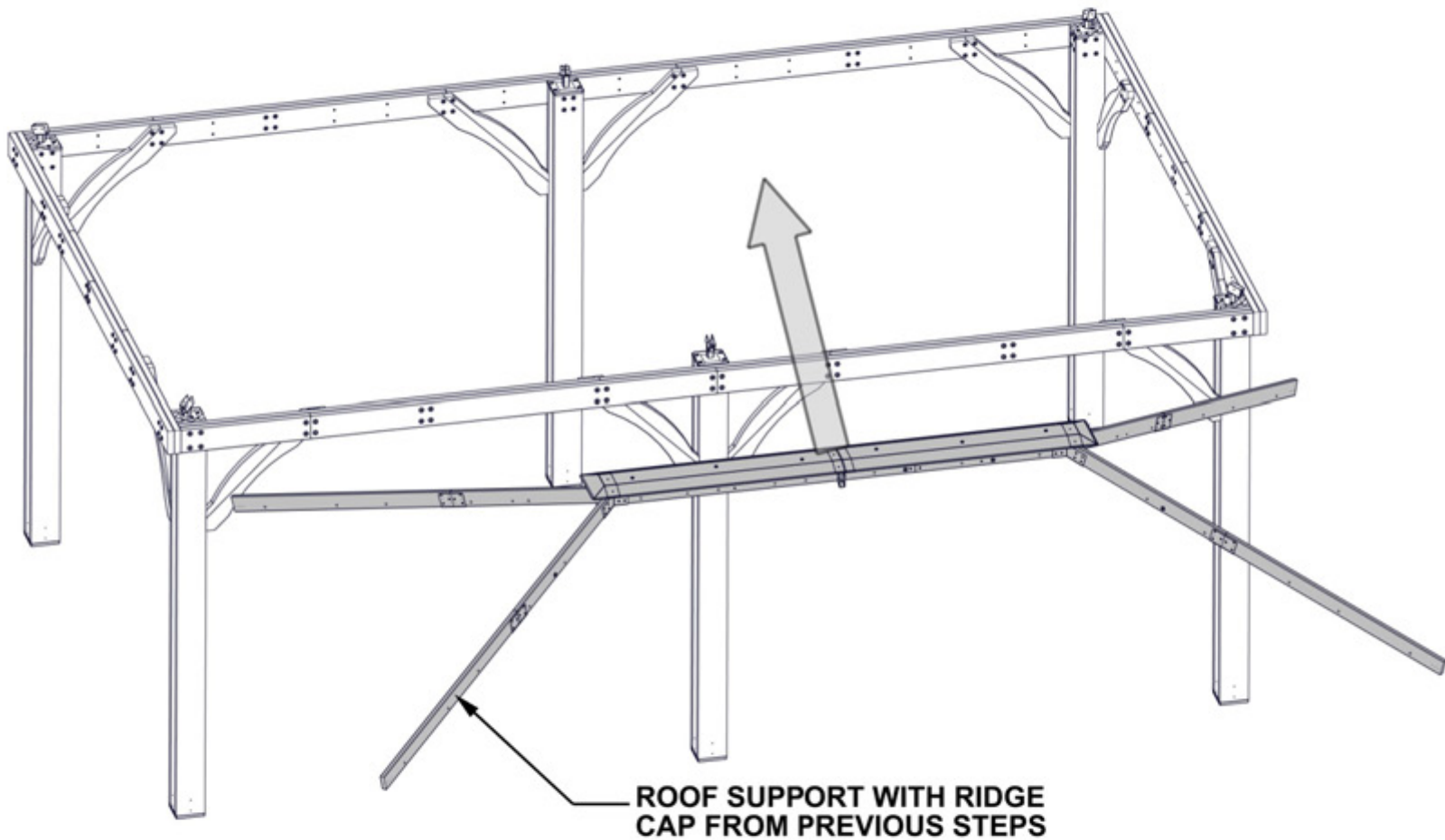

STEP 25 - ROOF SUPPORT ASSEMBLY

QTY	PART NUMBER	DESCRIPTION
12	H100385	SCREW PFH 8x1 BLK

REPEAT ON ALL FOUR CORNER POSTS

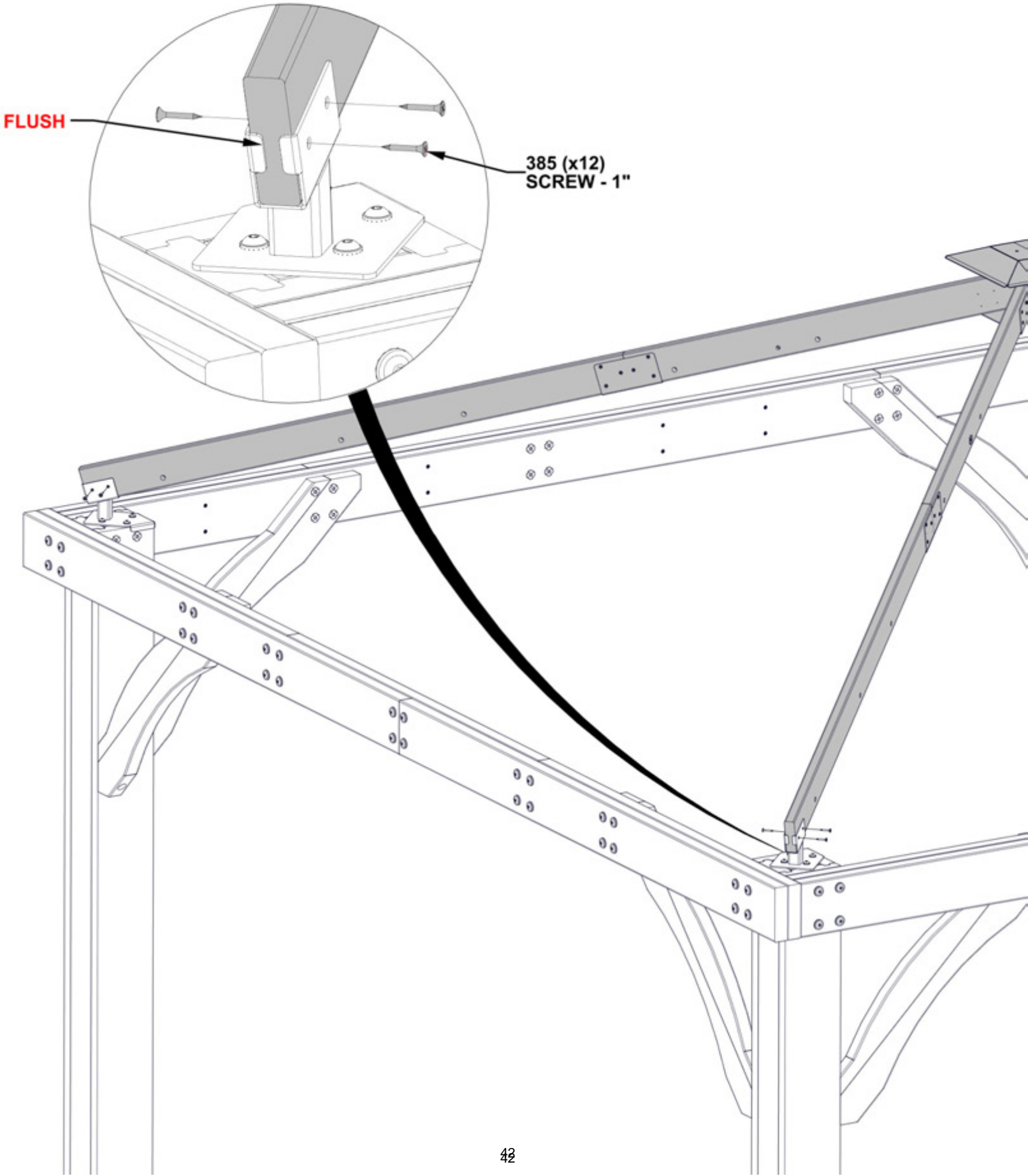

STEP 26 - ROOF SUPPORT ASSEMBLY

QTY	PART NUMBER	DESCRIPTION
4	H100379	TNUT-5/16" BLK



H05 RAFTER - W4L17525
(x2) 15/16"x3 3/8"x68 9/16" (24x86x1742)

REPEAT THIS STEP TWICE

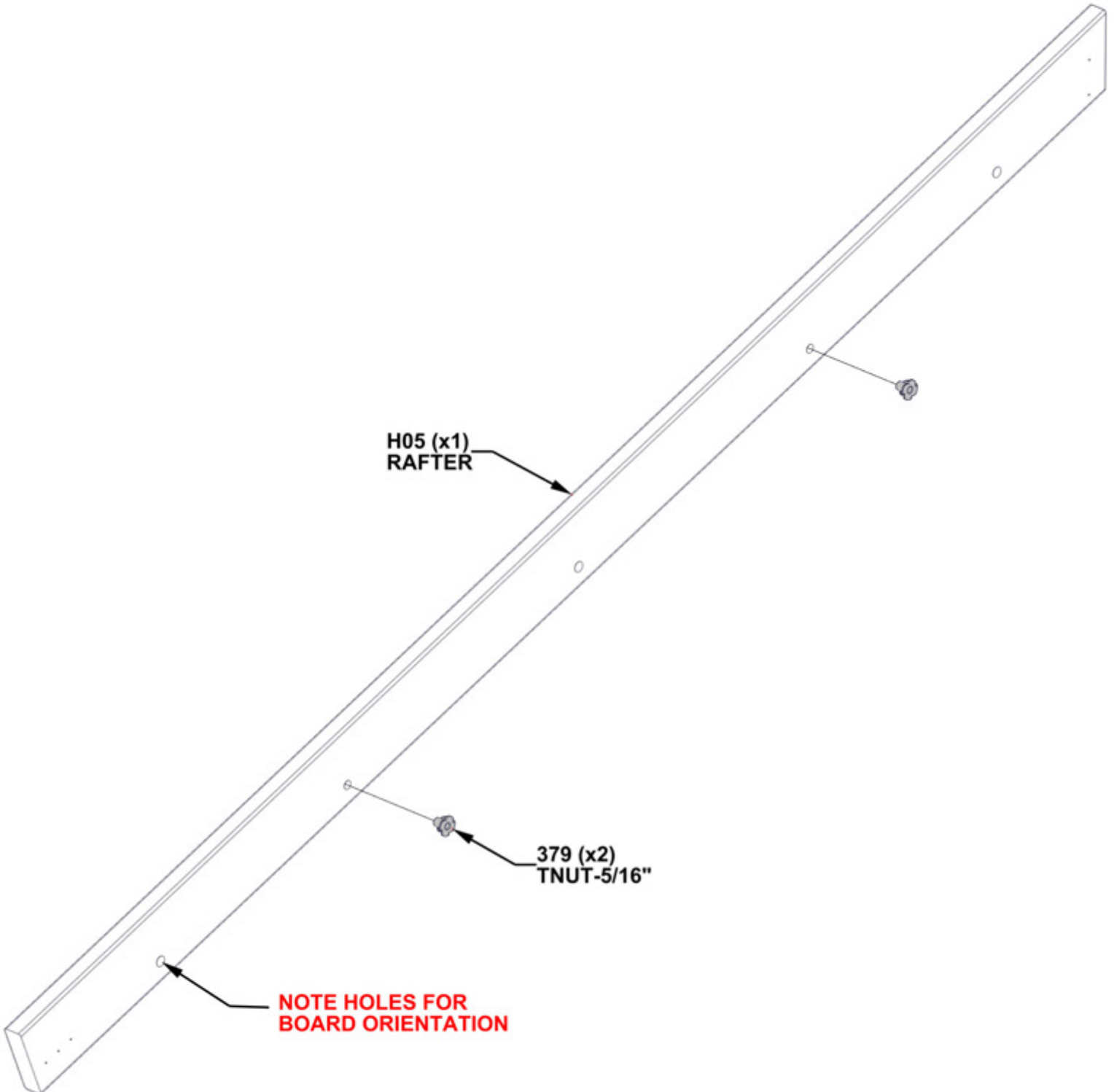

STEP 27 - ROOF SUPPORT ASSEMBLY



RAFTER ASSEMBLY FROM PREVIOUS STEP

QTY	PART NUMBER	DESCRIPTION
6	H100385	SCREW PFH 8x1 BLK

NOTE: HOLE FOR BOARD ORIENTATION

385 (x3) SCREW - 1"

385 (x3) SCREW - 1"

FLUSH

RAFTER ASSEMBLY FROM PREVIOUS STEP

NOTE: T-NUT ORIENTATION

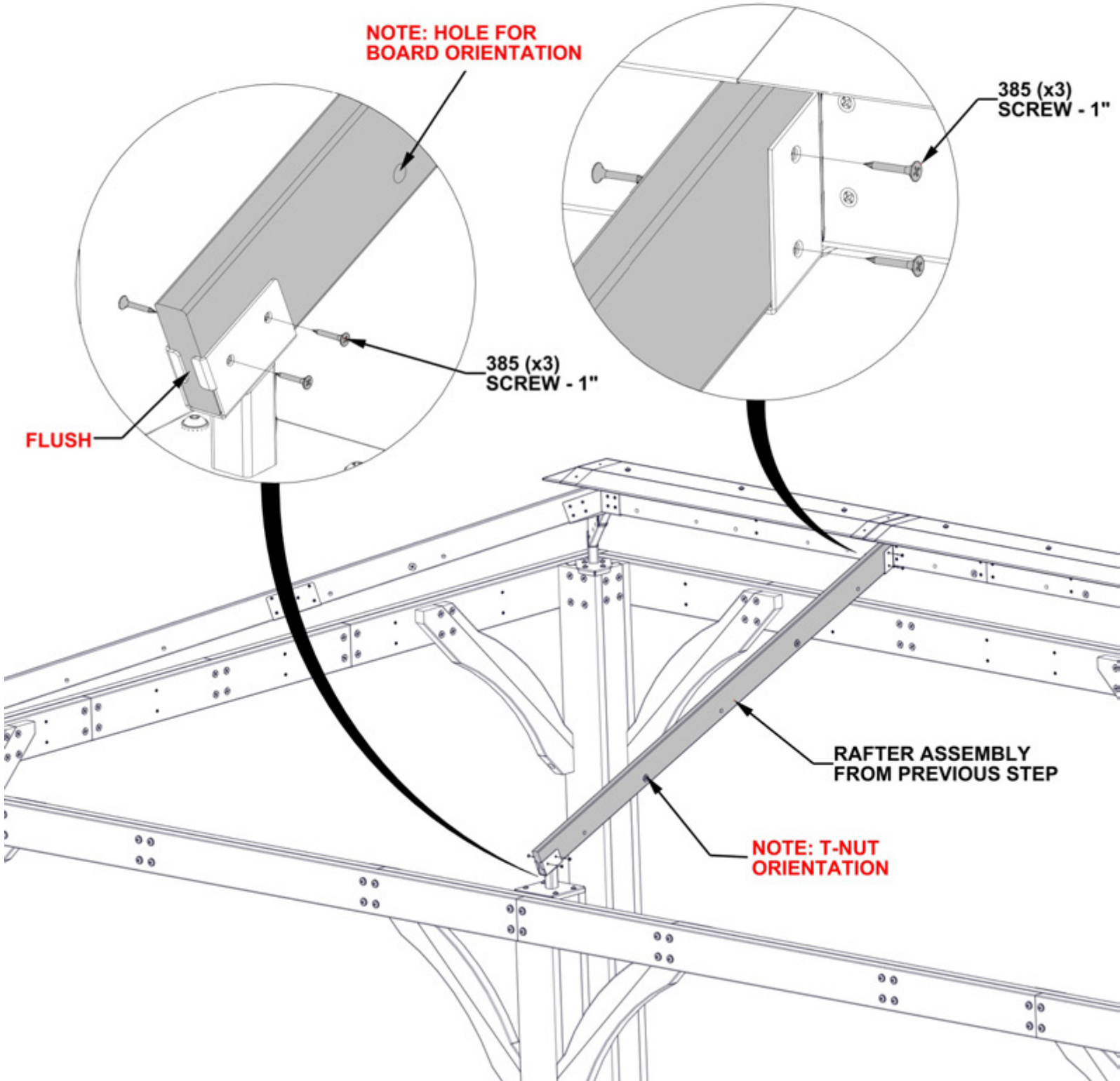

STEP 28 - ROOF SUPPORT ASSEMBLY

QTY	PART NUMBER	DESCRIPTION
6	H100385	SCREW PFH 8x1 BLK



RAFTER ASSEMBLY FROM PREVIOUS STEP

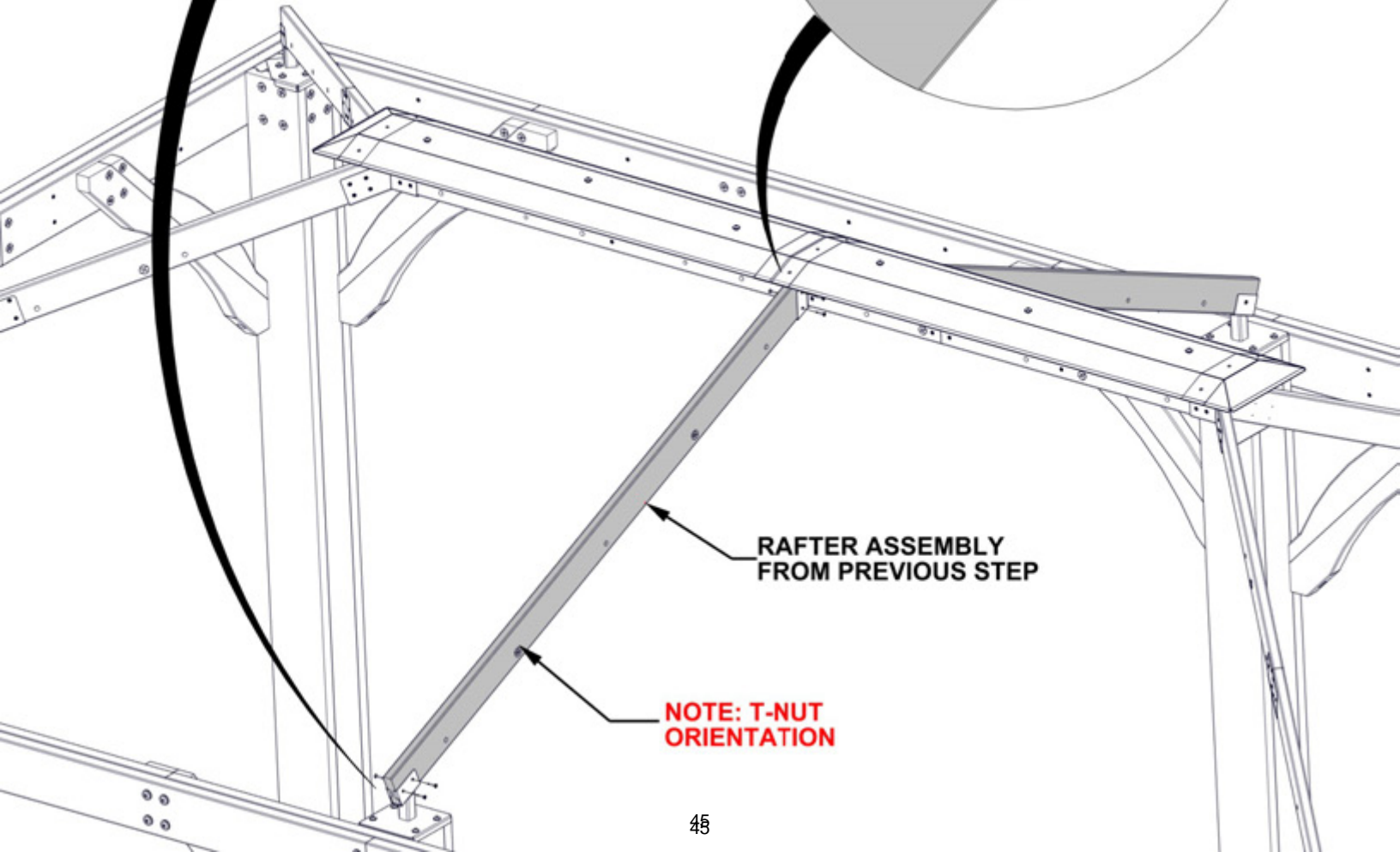
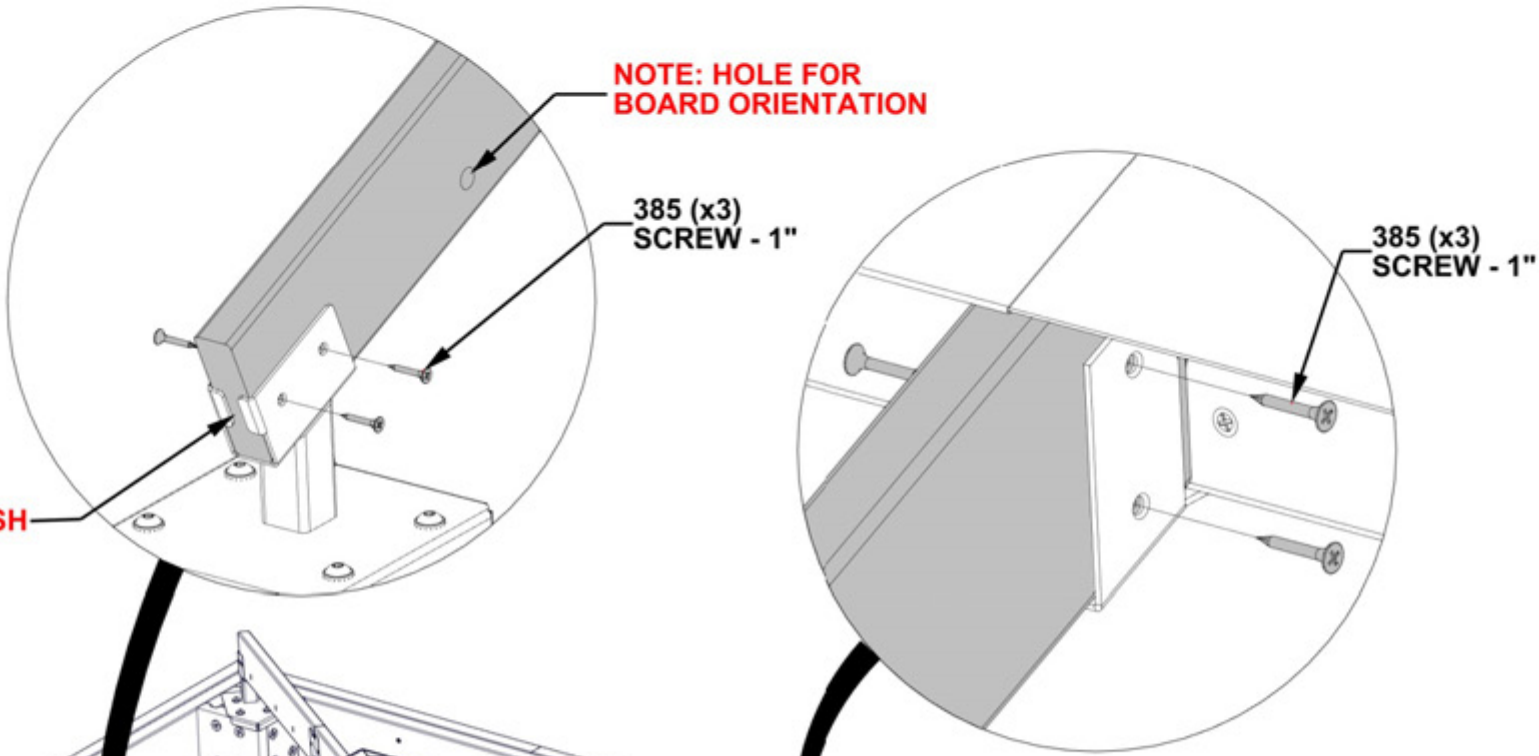

STEP 29 - 12FT ROOF PANEL ASSEMBLY

QTY	PART NUMBER	DESCRIPTION
4	H100398	TNUT-1/4" BLK
4	H100171	BOLT WH 1/4x1 BLK

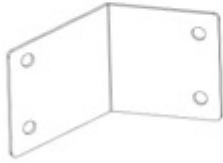

A4M01239 PANEL BRACKET (x1)

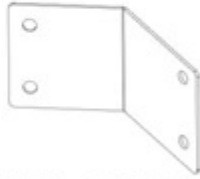

A4M01238 PANEL BRACKET (x1)



H08 RAFTER SUPPORT - W4L17530 (x1)
15/16"x3 3/8"x10 11/16" (24x86x272)

**INSERT T-NUTS FIRST
HAND TIGHTEN ONLY**

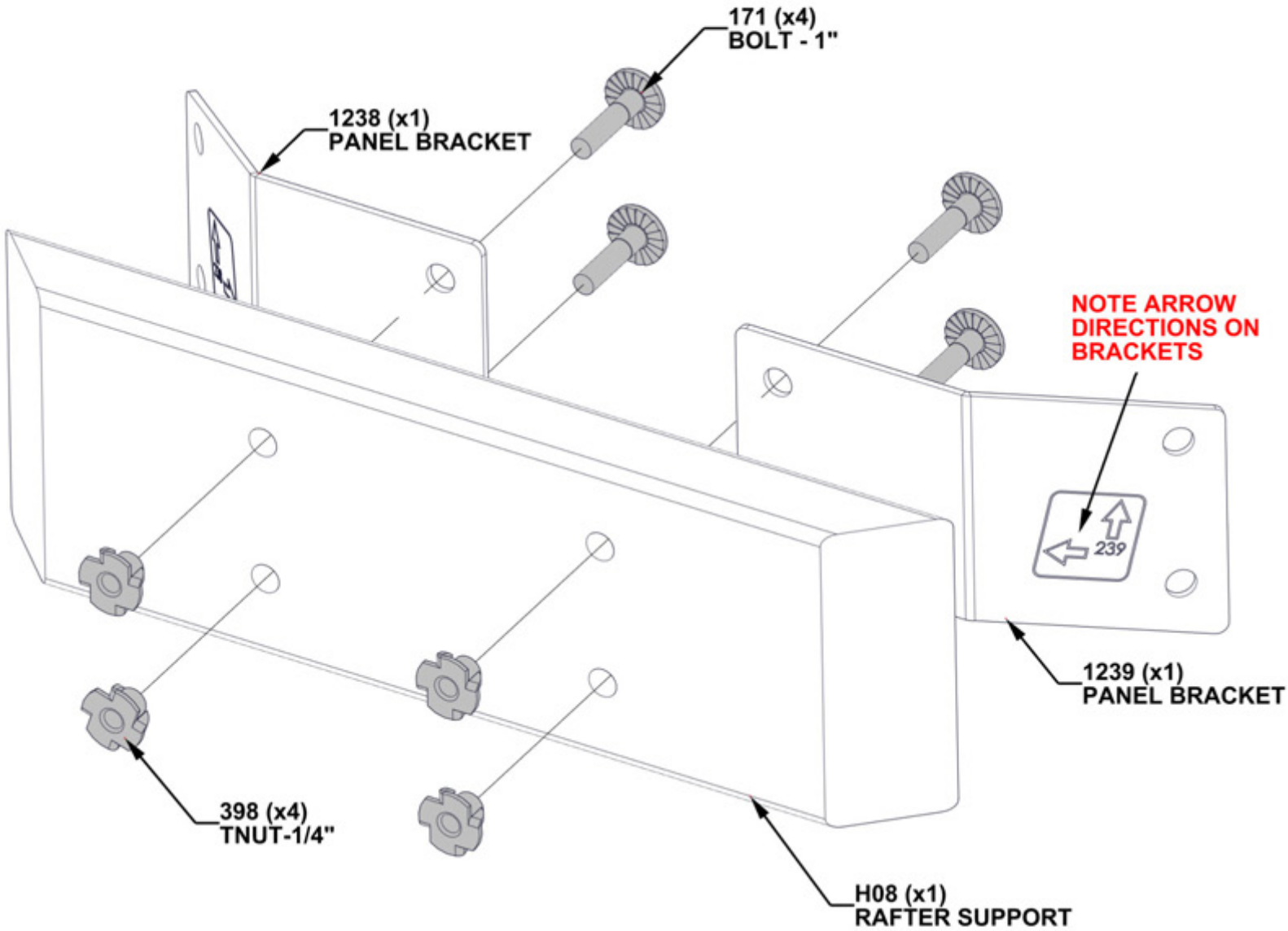

STEP 30 - 12FT ROOF PANEL ASSEMBLY

QTY	PART NUMBER	DESCRIPTION
4	H100398	TNUT-1/4" BLK
4	H100171	BOLT WH 1/4x1 BLK
24	H100385	SCREW PFH 8x1 BLK



H06 RAFTER - W4L17528
(x1) 15/16"x3 3/8"x44 1/2" (24x86x1130)



H07 RAFTER - W4L17529
(x1) 15/16"x3 3/8"x53 3/16" (24x86x1351)



H09 RAFTER - W4L17531
(x1) 15/16"x3 3/8"x53 3/16" (24x86x1351)



A4M01237 ROOF SUPPORT
(x2) SPLICE CLIP



H10 RAFTER - W4L17532
(x1) 15/16"x3 3/8"x44 1/2" (24x86x1130)

INSERT T-NUTS FIRST

TOP OF H07/H09 WILL NOT BE FLUSH

398 (x4)
TNUT-1/4"

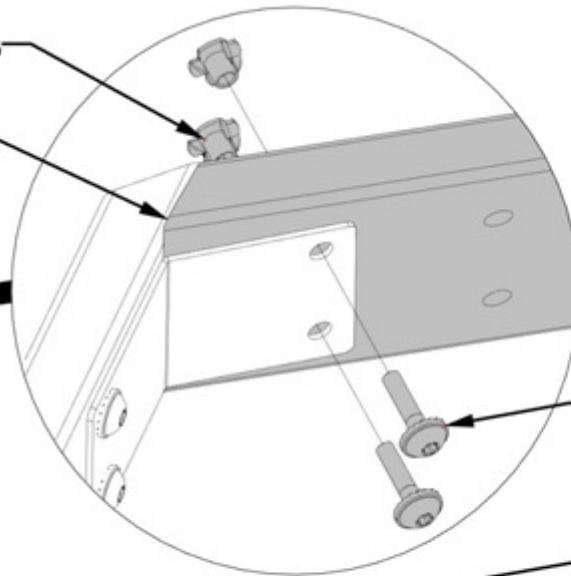

171 (x4)
BOLT - 1"

NOTE HOLES LOCATED AT BOTTOM OF RAFTERS

ROOF JOIST FROM STEP 29

H07 (x1)
RAFTER

H09 (x1)
RAFTER

H06 (x1)
RAFTER

385 (x24)
SCREW - 1"

ORIENT H09/H10 THE SAME AS H06/H07 WITH SINGLE HOLES TOWARDS BOTTOM

1237 (x2)
ROOF SUPPORT
SPLICE CLIP

H10 (x1)
RAFTER

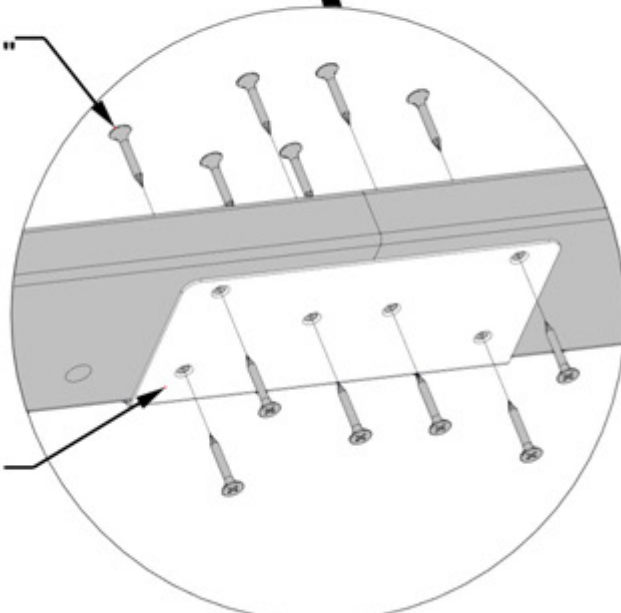

STEP 31 - 12FT ROOF PANEL ASSEMBLY

QTY	PART NUMBER	DESCRIPTION
12	H101030	SCREW CONFIRMAT 7x2 BLK

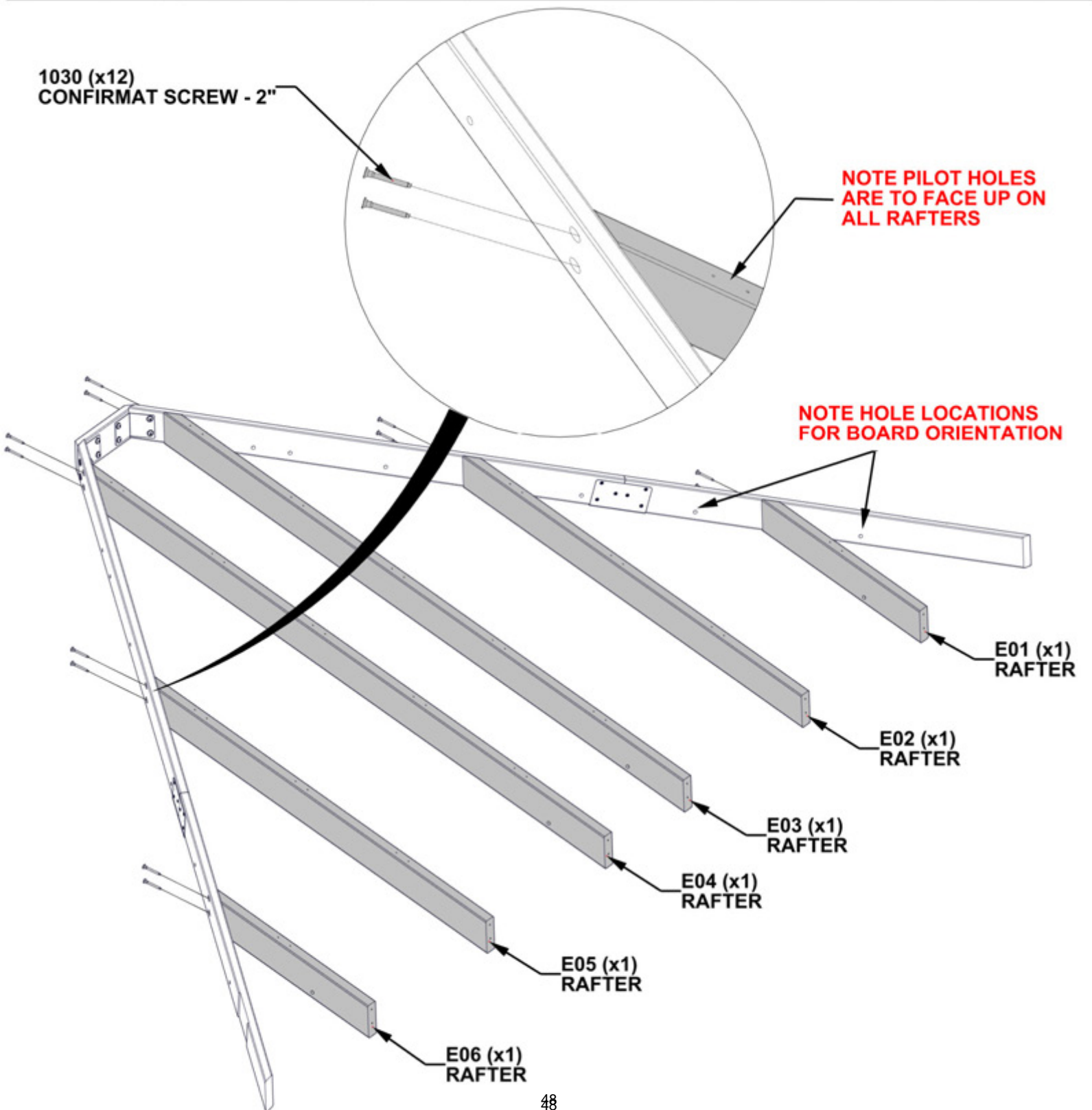
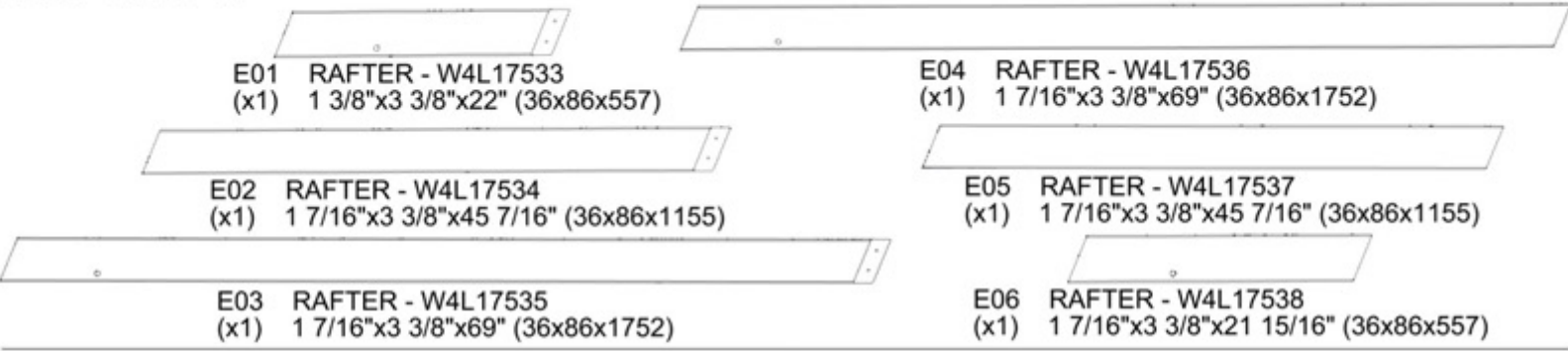

STEP 32 - 12FT ROOF PANEL ASSEMBLY

QTY	PART NUMBER	DESCRIPTION
12	H101030	SCREW CONFIRMAT 7x2 BLK



Q01 FASCIA - W4L17526
 (x1) 15/16"x4 7/16"x65 15/16" (24x112x1675)



Q02 FASCIA - W4L17527
 (x1) 24x4 7/16"x80 1/2" (24x112x2044)

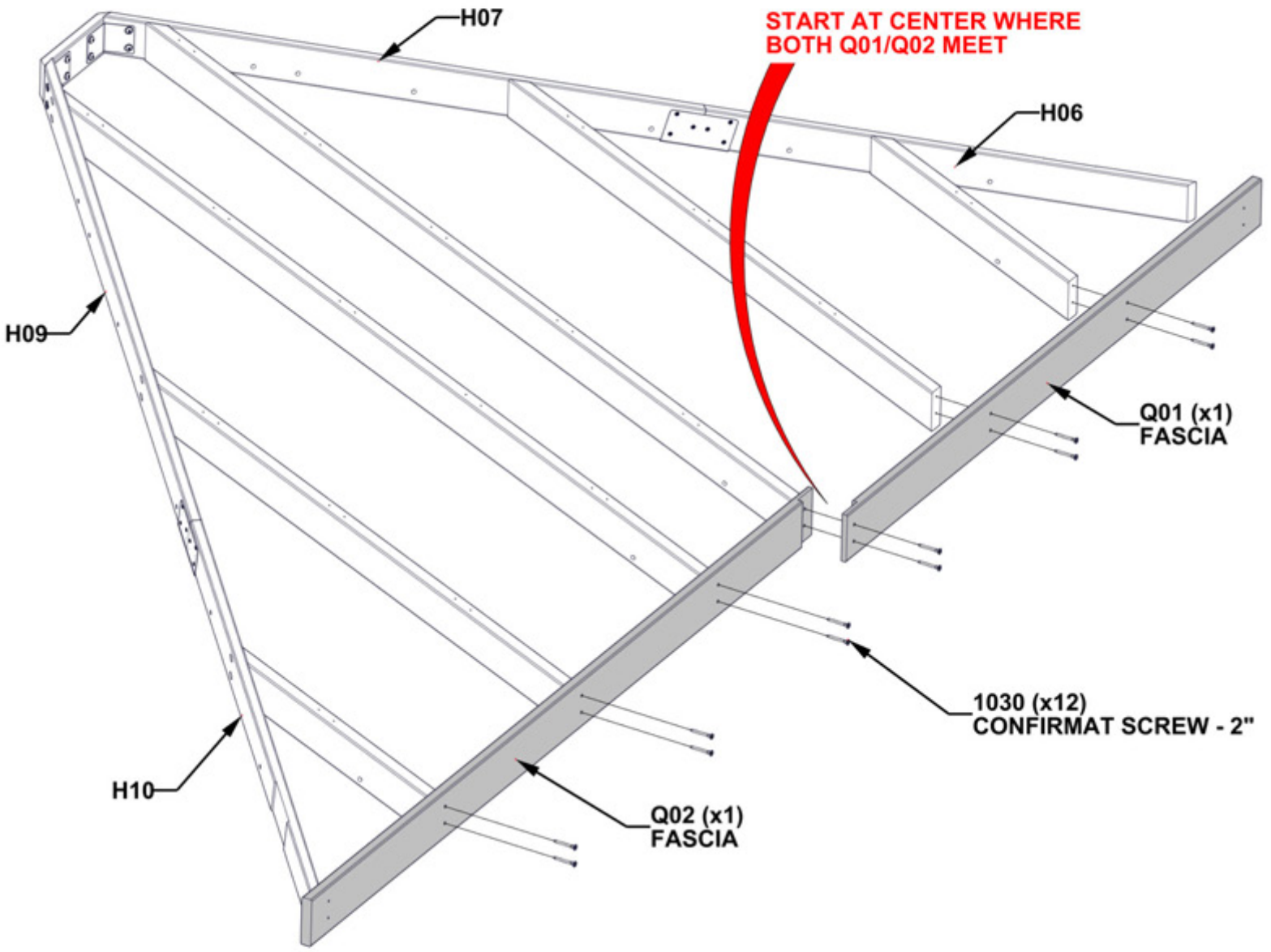

STEP 33 - 12FT ROOF PANEL ASSEMBLY

QTY	PART NUMBER	DESCRIPTION
4	H100382	SCREW PFH 8x1 3/4 BLK

TIPS:

- USING THE Q02 BOARD AS A GUIDE AND A 1/8" DRILL BIT, DRILL PILOT HOLES INTO THE H10 BOARD USING THE DIMENSION BELOW.
- REPEAT ON OPPOSITE END USING Q01 AS A GUIDE TO DRILL PILOT HOLES INTO THE H06 BOARD.

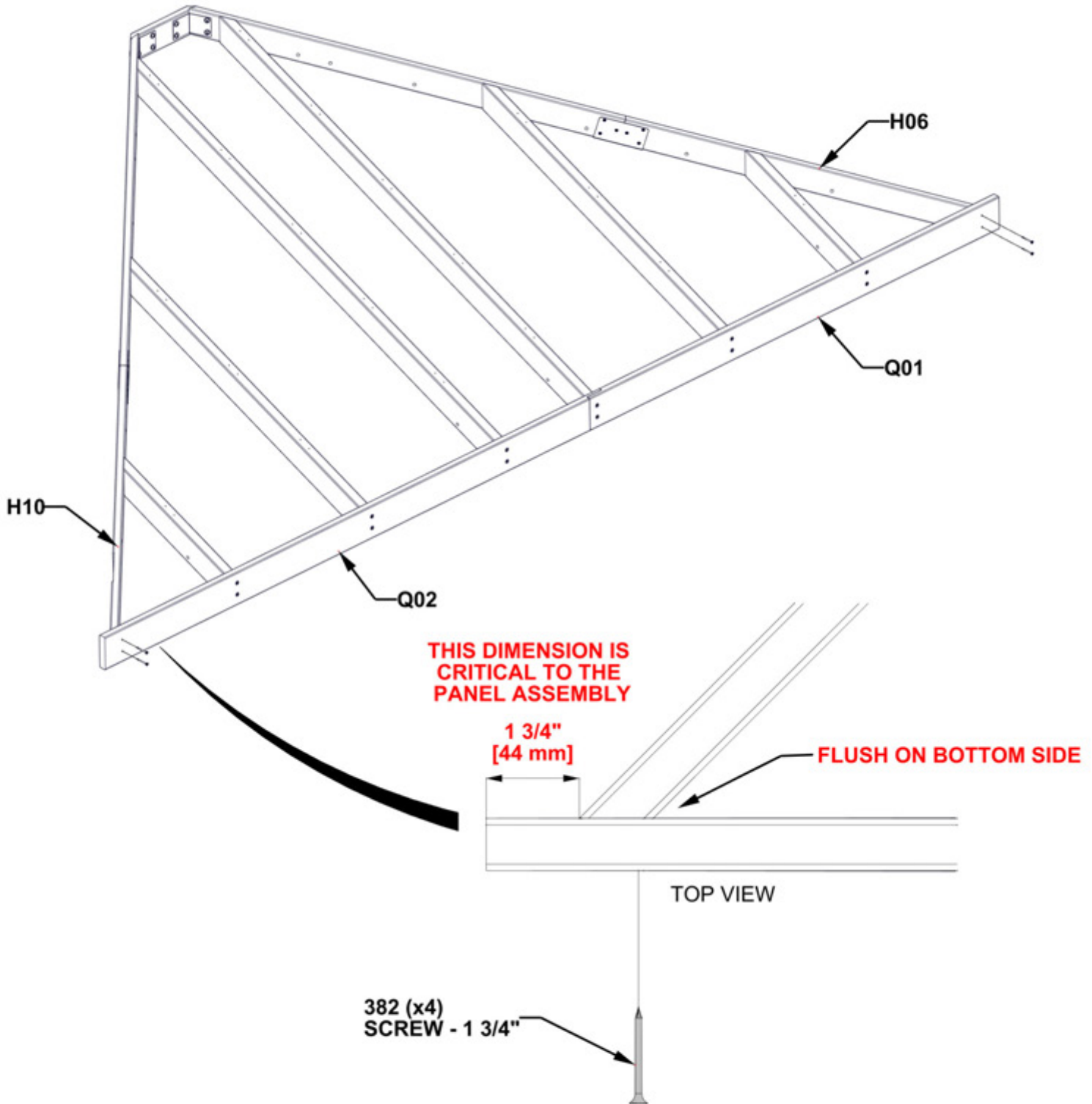

STEP 34 - 12FT ROOF PANEL ASSEMBLY

TIP: LOOSEN HARDWARE TO ADJUST FOR SQUARING IF NEEDED.

CRITICAL:

- SQUARE UNIT BEFORE PROCEEDING TO NEXT STEPS.
- THE BELOW DIMENSIONS ARE CRITICAL TO THE FINAL ROOF ASSEMBLY.
- DIMENSIONS ARE FROM CORNER TO CORNER OF ROOF PANEL.
- MEASUREMENTS SHOULD BE WITHIN $\pm 1/4"$.
- MEASUREMENTS OUTSIDE OF TOLERANCE WILL LEAD TO THE INABILITY TO ASSEMBLE THE ROOF.

ONCE SQUARE, TIGHTEN ALL HARDWARE FROM PREVIOUS STEPS

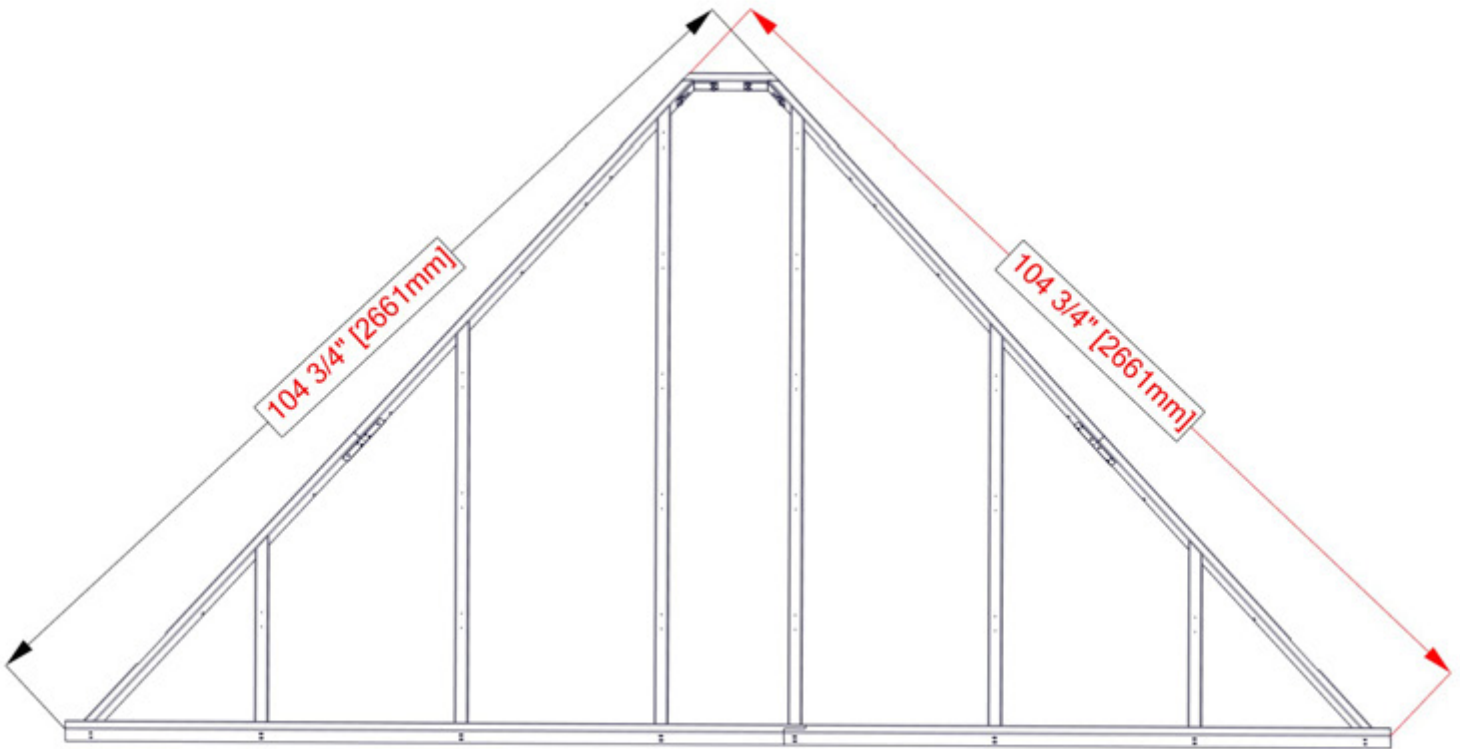

STEP 35 - 12FT ROOF PANEL ASSEMBLY

QTY	PART NUMBER	DESCRIPTION
58	H100391	SCREW PFH 8x2 BLK

T01 PURLIN - W4L17546
(x1) 15/16"x1 5/16"x12 7/8" (24x34x327)

H17 PURLIN - W4L17545
(x1) 15/16"x3 3/8"x27 1/4" (24x86x692)

H16 PURLIN - W4L17544
(x1) 15/16"x3 3/8"x51 7/16" (24x86x1307)

H15 PURLIN - W4L17543
(x1) 15/16"x3 3/8"x75 11/16" (24x86x1922)

H14 PURLIN - W4L17542
(x1) 15/16"x3 3/8"x43 7/8" (24x86x1114)

H13 PURLIN - W4L17541
(x1) 15/16"x3 3/8"x58 3/8" (24x86x1483)

H12 PURLIN - W4L17540
(x1) 15/16"x3 3/8"x70 1/2" (24x86x1791)

H11 PURLIN - W4L17539
(x1) 15/16"x3 3/8"x56" (24x86x1422)

TIPS:

- ALIGN PURLIN PILOT HOLES WITH RAFTER PILOT HOLES.
- ATTACH SCREWS FROM THE CENTER AND WORK OUTWARD.
- H09/H10 & H06/H07 BOARDS DO NOT HAVE PILOT HOLES FOR OUTSIDE EDGE SCREWS.
- USING THE PURLINS AS A GUIDE AND A 1/8" DRILL BIT, DRILL PILOT HOLES INTO H09/H10 & H06/H07 BOARDS.

NOTE: T01 IS TO BE FLUSH AND WILL NOT OVERHANG SIDES

391 (x58)
SCREW - 2"

5/8"
[15mm]

IF PURLINS OVERHANG MORE THAN 5/8", CUT DOWN TO 5/8".

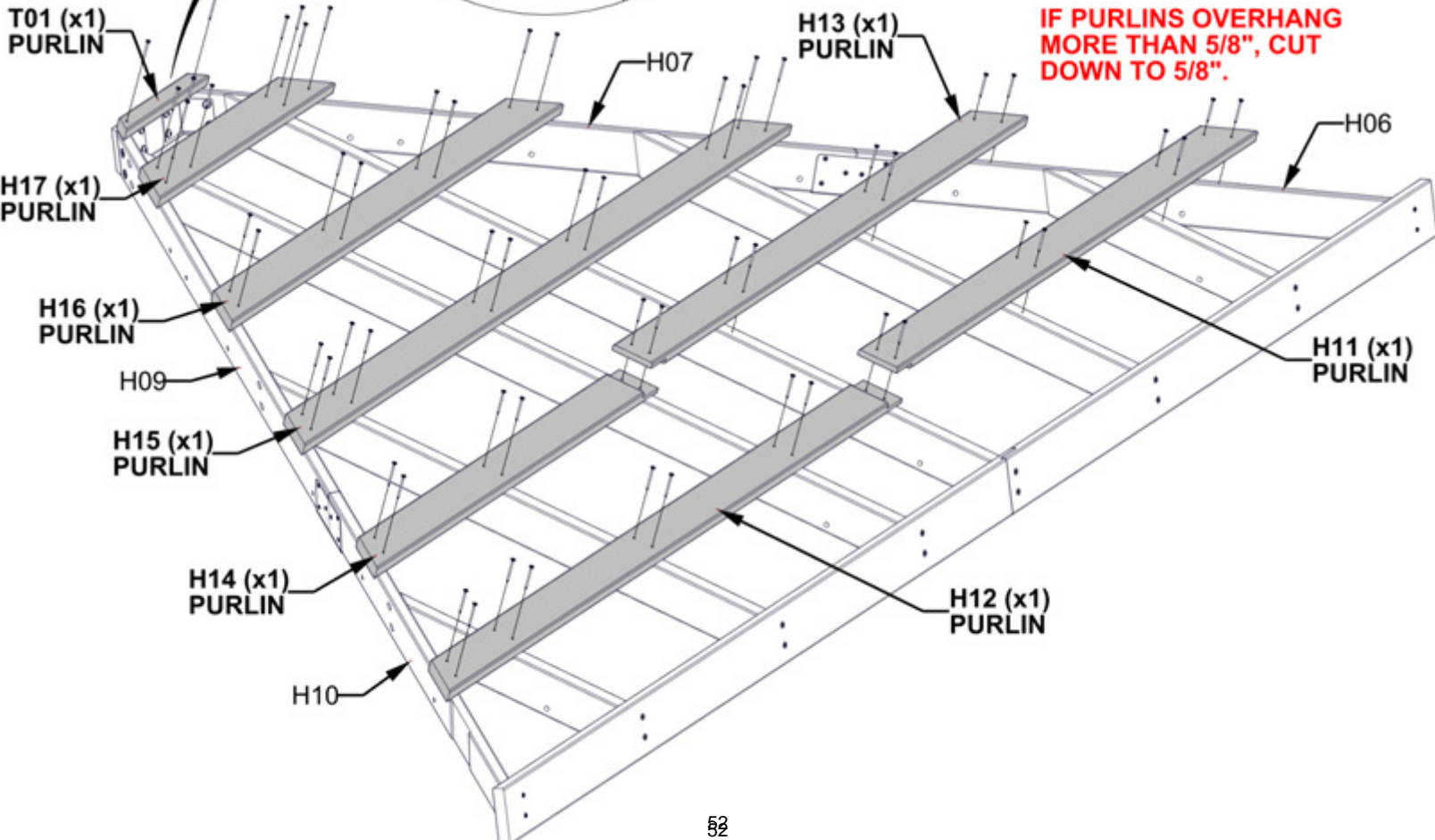

STEP 36 - 12FT ROOF PANEL ASSEMBLY

QTY	PART NUMBER	DESCRIPTION
20	H100833	SCREW WOODGRIP 10-16x3/4

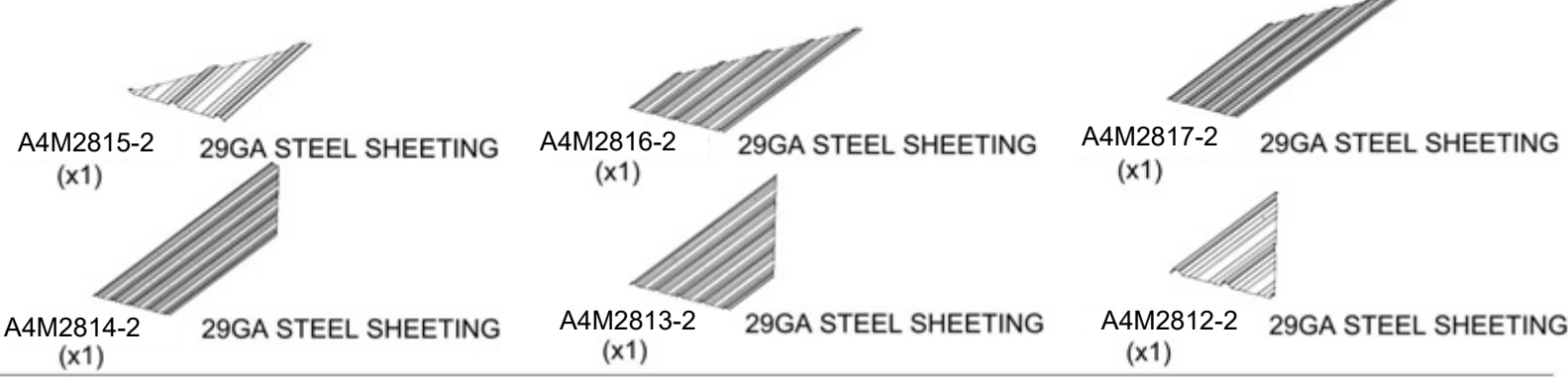

- TIPS:**
- REMOVE PROTECTIVE BLUE FILM.
 - STARTING IN THE CENTER, PLACE SHEETING AS SHOWN BELOW.
 - OVERLAP SHEETING BY ONE RIDGE.
 - SHEETING SHOULD BE FLUSH WITH PURLIN ENDS AND Q02 ROOF FASCIA.
 - ONCE SHEETING IS IN PLACE, IT IS RECOMMENDED TO ADD H100833 SCREWS IN THE MIDDLE OF THE SHEETS TO HOLD SHEETING FOR THE NEXT STEP.

WARNING: GLOVES ARE RECOMMENDED WHEN HANDLING STEEL ROOF PIECES

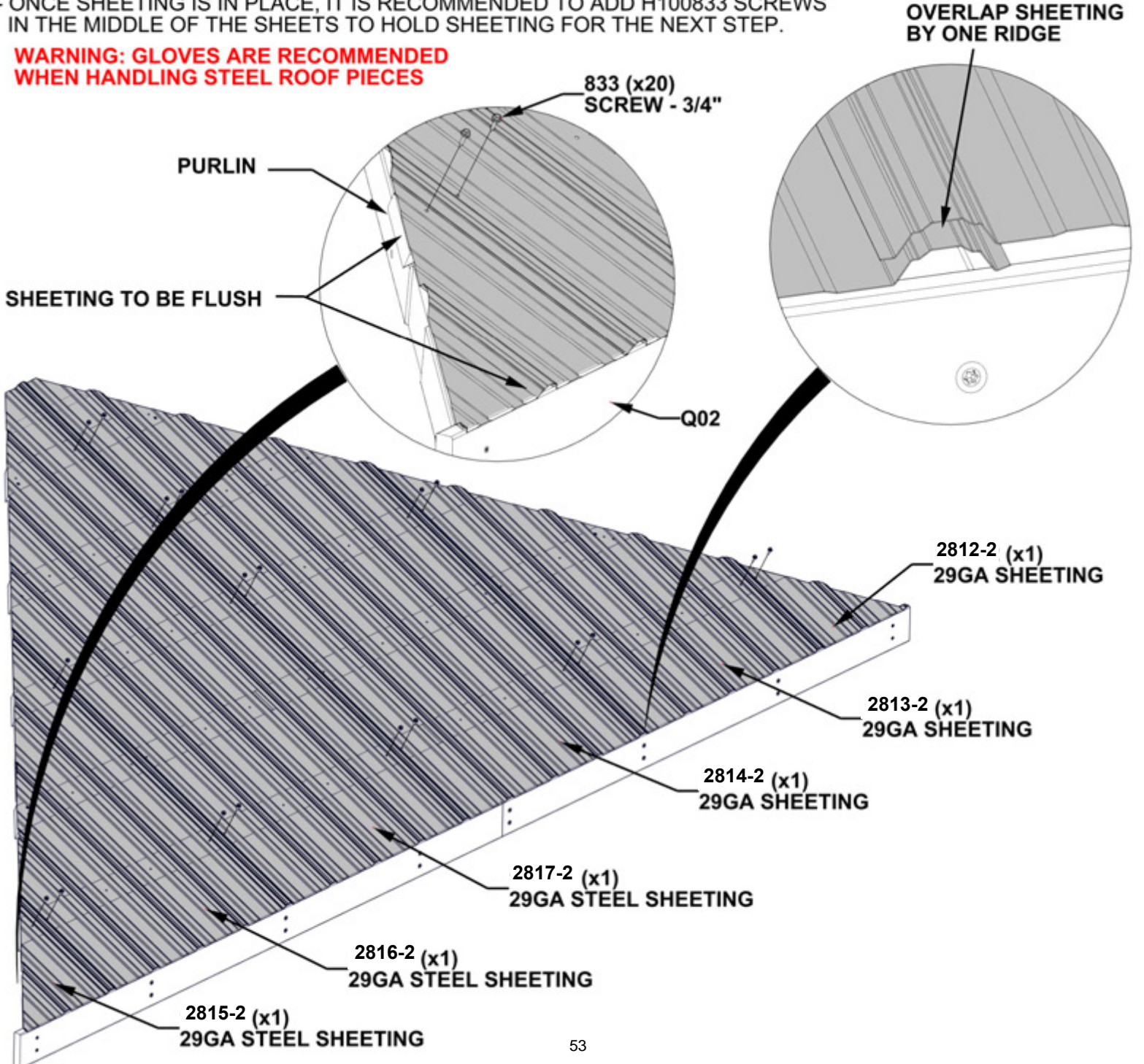

STEP 37 - 12FT ROOF PANEL ASSEMBLY

QTY	PART NUMBER	DESCRIPTION
8	H100833	SCREW WOODGRIP 10-16x3/4



- TIPS:**
- REMOVE PROTECTIVE BLUE FILM.
 - POSITION THE RIDGE CAP CHANNEL OVER THE EDGE OF THE ROOF PANELS WITH THE WIDER SIDE OF THE CHANNEL ON THE BOTTOM.
 - MAKE SURE THE PANELS ARE FULLY SEATED INTO THE CHANNEL.

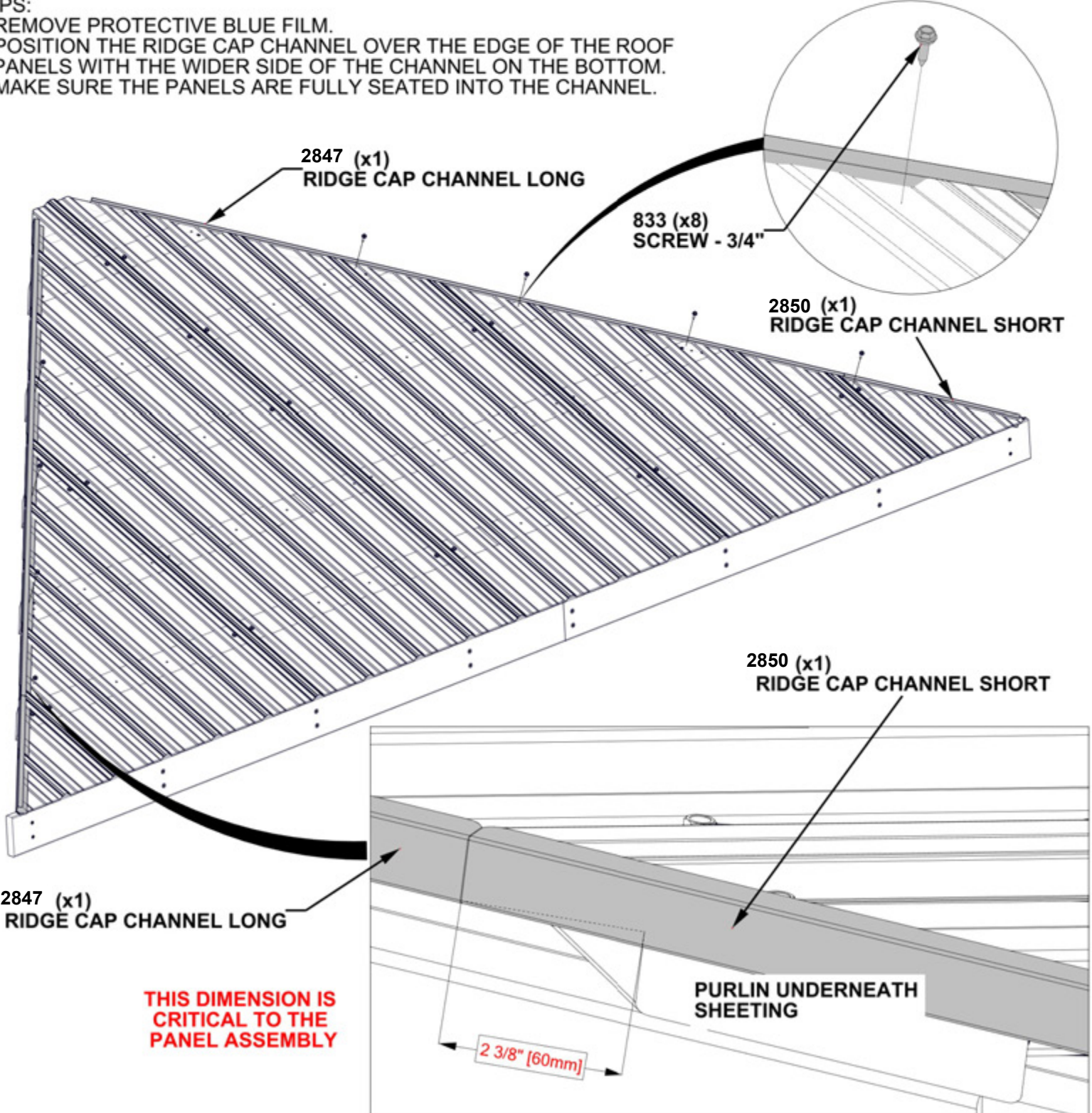

THIS DIMENSION IS CRITICAL TO THE PANEL ASSEMBLY

2 3/8" [60mm]

STEP 38 - 12FT ROOF PANEL ASSEMBLY

QTY	PART NUMBER	DESCRIPTION
32	H100833	SCREW WOODGRIP 10-16x3/4

- TIPS:
- INSERT REMAINING SCREWS TO FASTEN SHEET METAL IN PLACE.
 - MAKE SURE SHEET EDGES ARE FLUSH AS SHOWN.

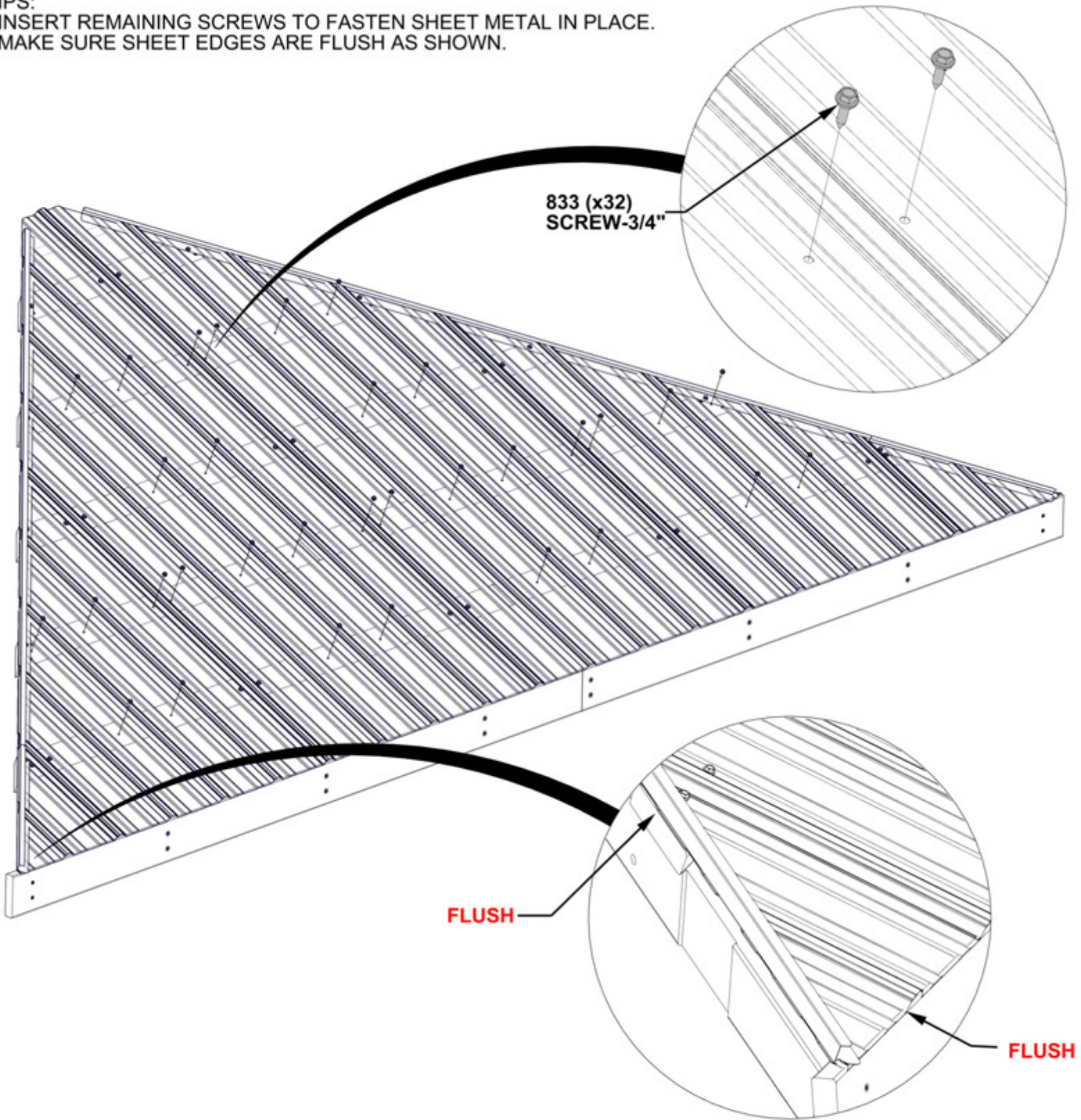

**REPEAT 12FT ROOF PANEL
ASSEMBLY STEPS 29 THROUGH 38.**

STEP 39 - LEFT PANEL ASSEMBLY

QTY	PART NUMBER	DESCRIPTION
2	H100171	BOLT WH 1/4x1 BLK
2	H100398	TNUT-1/4" BLK



H20 RAFTER SUPPORT - W4L17549
(x1) 15/16"x3 3/8"x46 3/8" (24x86x1177)



A4M01191 PANEL BRACKET
(x1)

**INSERT T-NUTS FIRST
HAND TIGHTEN ONLY**

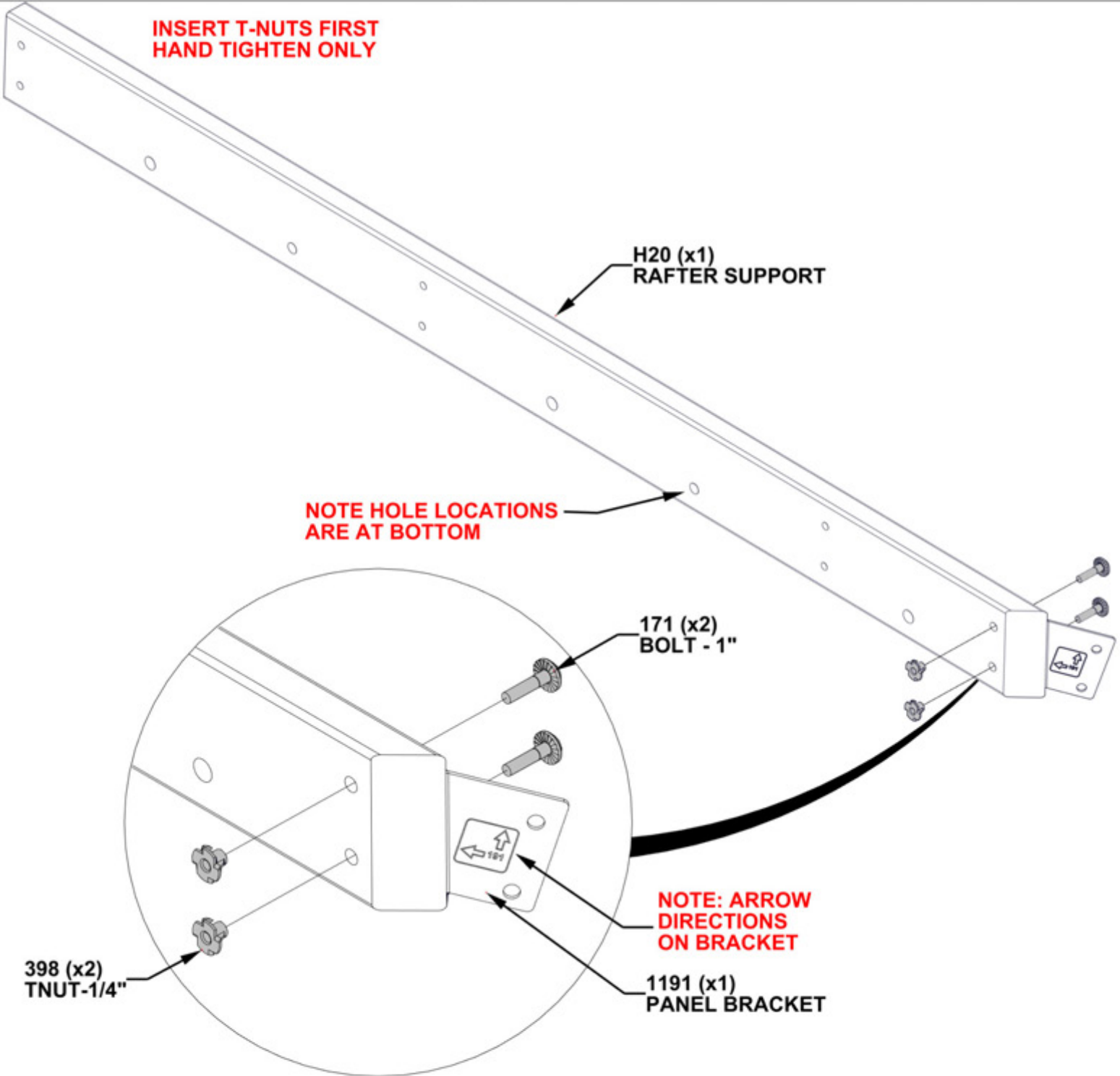

STEP 40 - LEFT PANEL ASSEMBLY

QTY	PART NUMBER	DESCRIPTION
2	H100398	TNUT-1/4" BLK
12	H100385	SCREW PFH 8x1 BLK



H18 RAFTER - W4L17547
(x1) 15/16"3 3/8"44 1/2" (24x86x1130)



H19 RAFTER - W4L17548
(x1) 15/16"x3 3/8"x60 5/8" (24x86x1540)



A4M01237 ROOF SUPPORT SPLICE CLIP
(x1)

INSERT T-NUTS FIRST

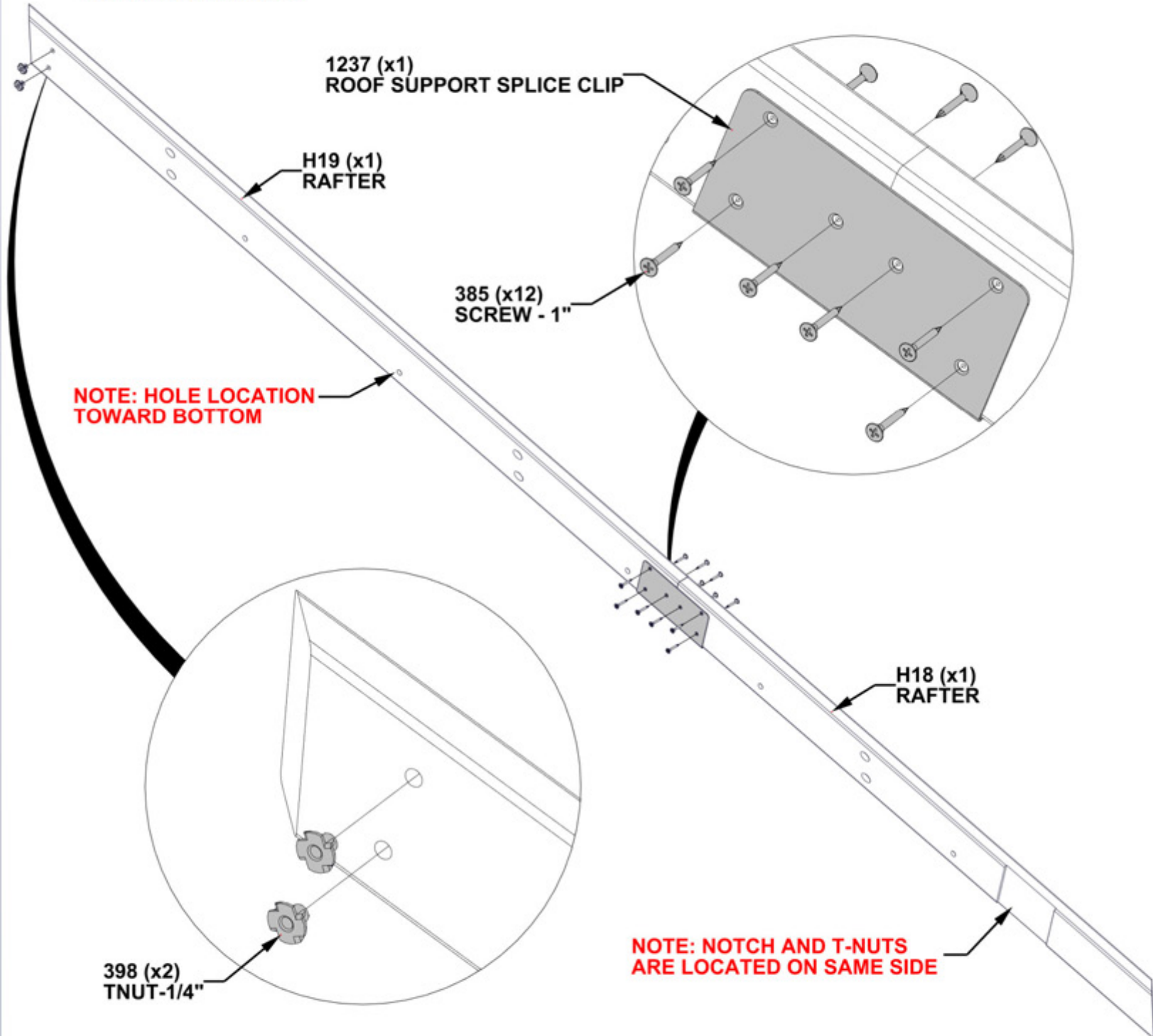

STEP 41 - LEFT PANEL ASSEMBLY

QTY	PART NUMBER	DESCRIPTION
2	H100171	BOLT WH 1/4x1 BLK



H18/H19 RAFTER ASSEMBLY
FROM PREVIOUS STEP

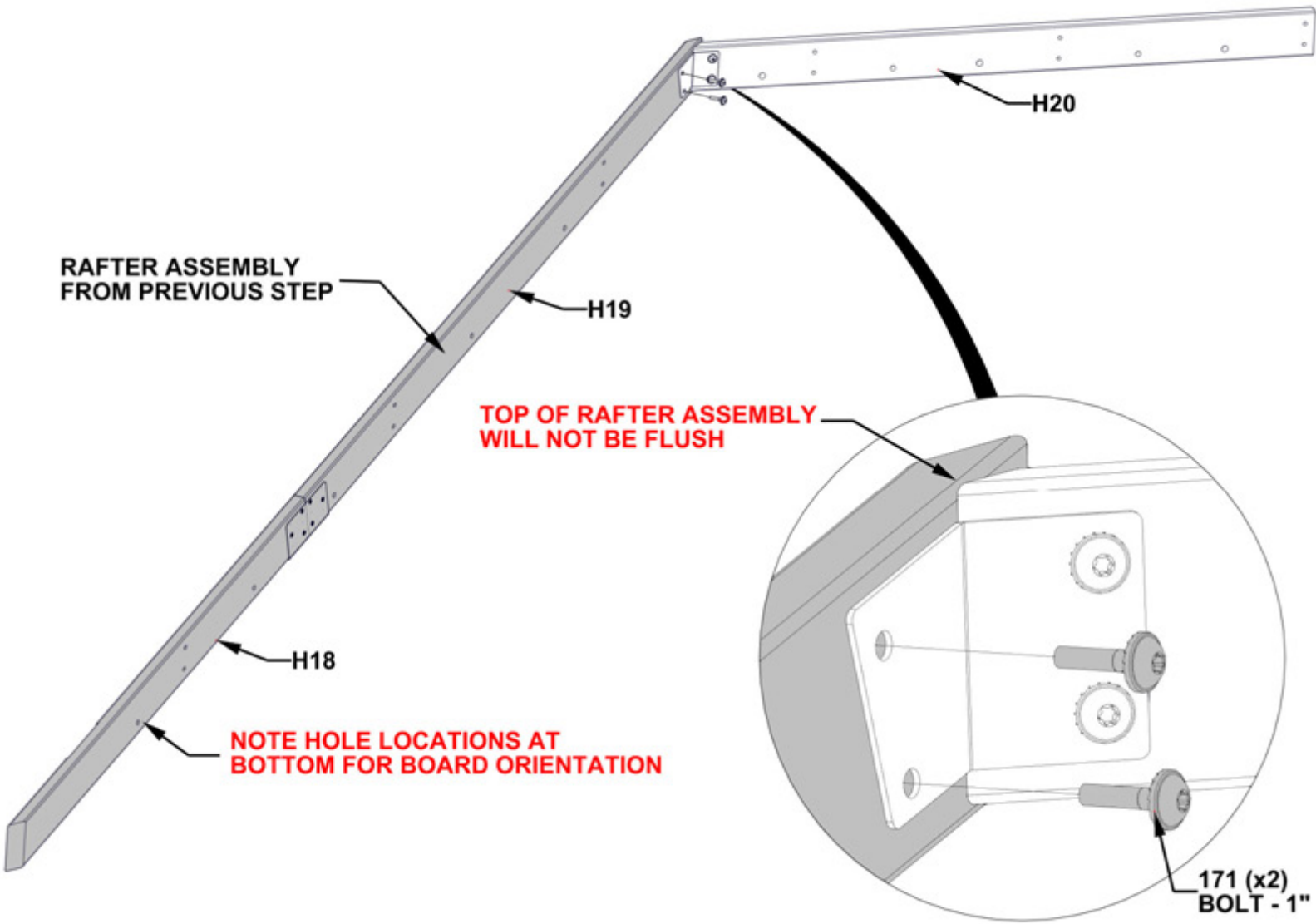

STEP 42 - LEFT PANEL ASSEMBLY

QTY	PART NUMBER	DESCRIPTION
6	H101030	SCREW CONFIRMAT 7x2 BLK

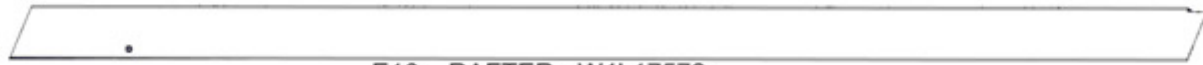

E16 RAFTER - W4L17572
(x1) 1 7/16"x3 3/8"x76 1/8" (36x86x1934)

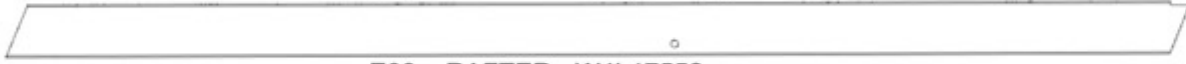

E08 RAFTER - W4L17552
(x1) 1 7/16"x3 3/8"x76 1/8" (36x86x1934)



E07 RAFTER - W4L17551
(x1) 1 7/16"x3 3/8"x76 1/8" (36x86x1934)

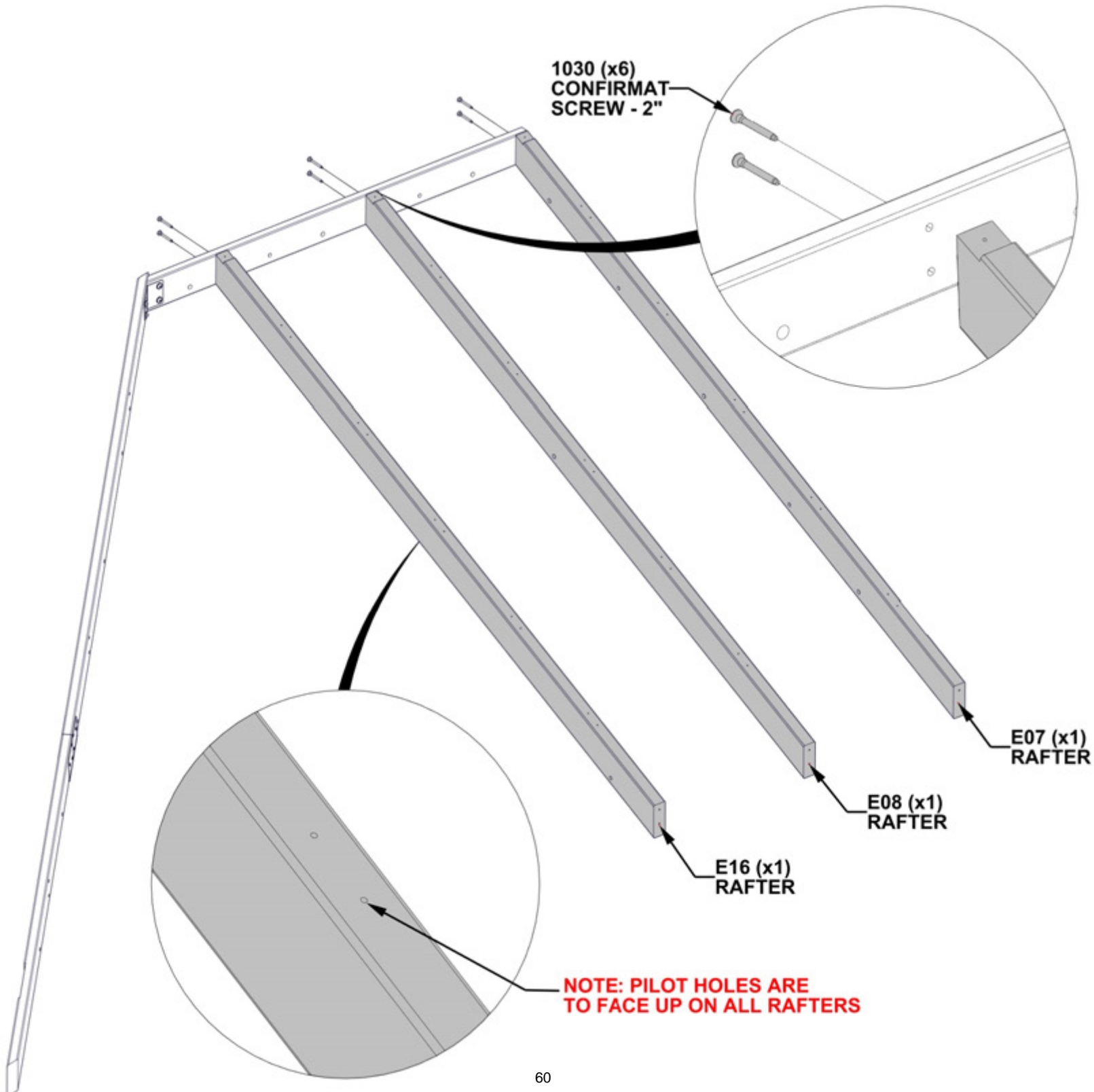

STEP 43 - LEFT PANEL ASSEMBLY

QTY	PART NUMBER	DESCRIPTION
6	H101030	SCREW CONFIRMAT 7x2 BLK



E11 RAFTER - W4L17555
(x1) 1 7/16"3 3/8"20 3/16" (36x86x512)



E10 RAFTER - W4L17554
(x1) 1 7/16"x3 3/8"x43 5/8" (36x86x1109)



E09 RAFTER - W4L17553
(x1) 1 7/16"3 3/8"67 1/8" (36x86x1705)

1030 (x6)
CONFIRMAT SCREW - 2"

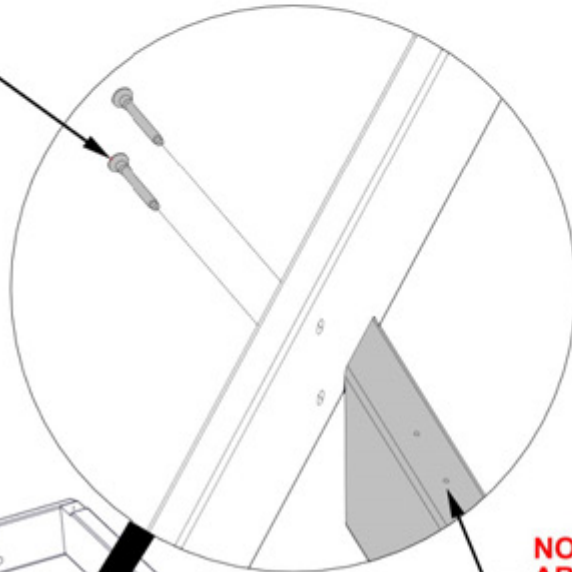

NOTE: PILOT HOLES ARE TO FACE UP ON ALL RAFTERS

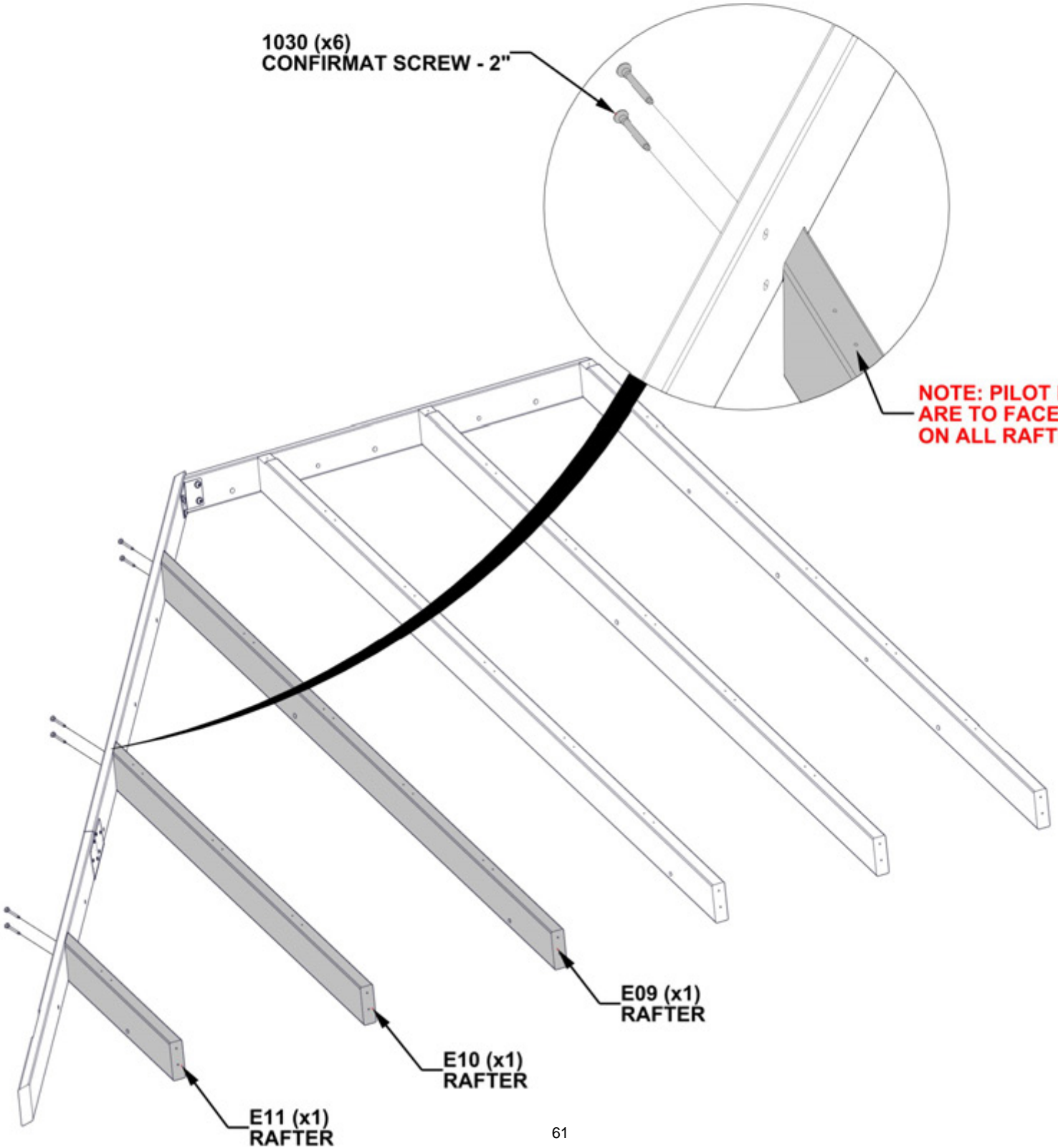

STEP 44 - LEFT PANEL ASSEMBLY

QTY	PART NUMBER	DESCRIPTION
12	H101030	SCREW CONFIRMAT 7x2 BLK



Q03 FASCIA - W4L17550
(x1) 15/16"x4 7/16"x63 3/16" (24x112x1605)



Q04 FASCIA - W4L17556
(x1) 15/16"x4 7/16"x57 1/4" (24x112x1454)

START AT RIGHT RAFTER AND WORK TOWARDS THE LEFT, OVERHANGING END AS SHOWN

TIP: RAFTER MAY NEED TO BE LOOSENED UP TO ATTACH FASCIA BOARDS

THIS DIMENSION IS CRITICAL TO THE PANEL ASSEMBLY

9/16"
[14mm]

TOP VIEW

Q04 (x1)
FASCIA

NOTE: ALIGN FASCIA WITH PILOT HOLES IN ENDS OF RAFTERS

Q03 (x1)
FASCIA

1030 (x12)
CONFIRMAT SCREW - 2"

STEP 45 - LEFT PANEL ASSEMBLY

QTY	PART NUMBER	DESCRIPTION
2	H100382	SCREW PFH 8x1 3/4 BLK

TIPS:

- USING THE Q03 BOARD AS A GUIDE AND A 1/8" DRILL BIT, DRILL PILOT HOLES INTO THE H18 BOARD USING THE DIMENSION BELOW.

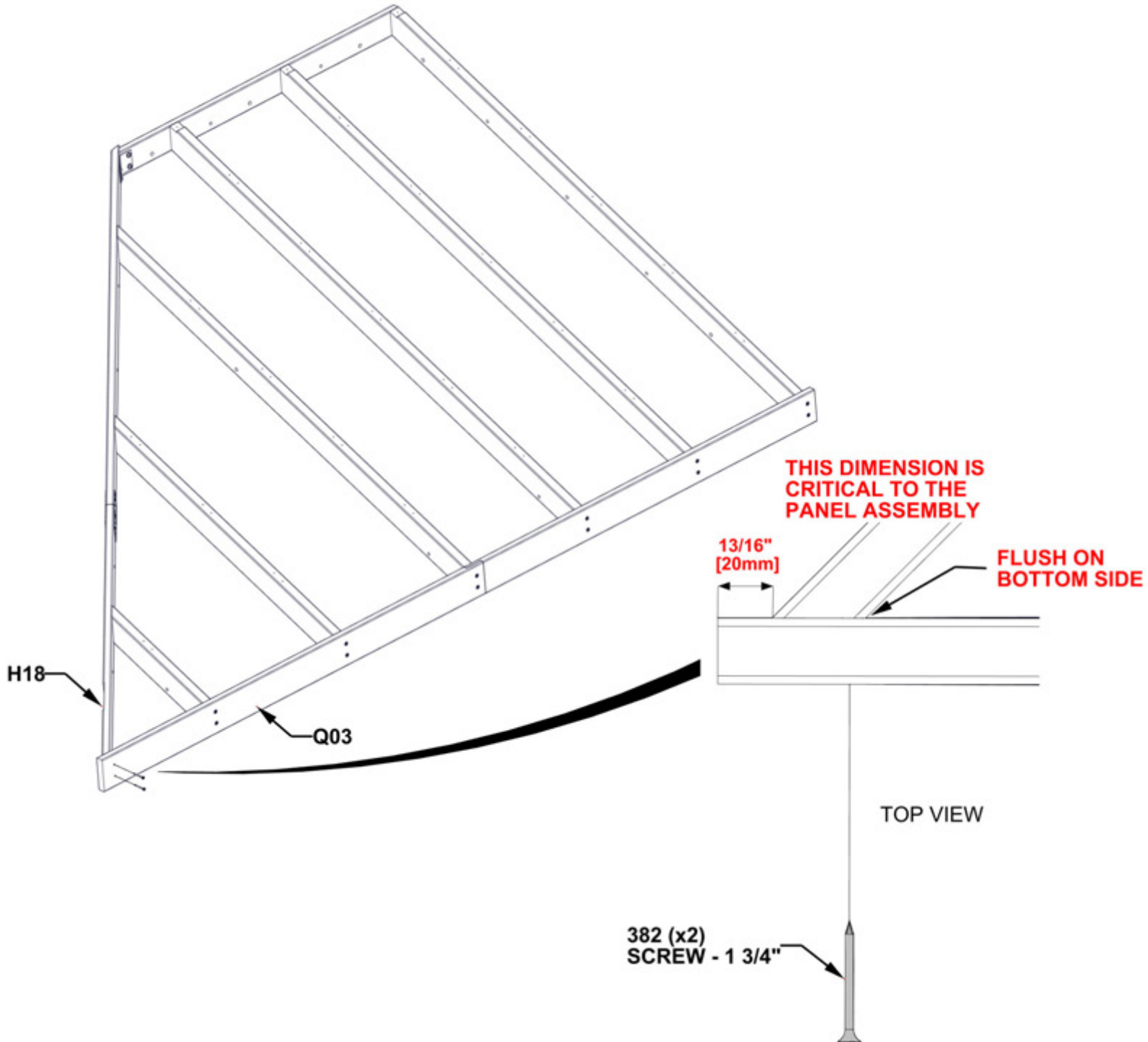

STEP 46 - LEFT PANEL ASSEMBLY

TIP: LOOSEN HARDWARE TO ADJUST FOR SQUARING IF NEEDED.

CRITICAL:

- SQUARE UNIT BEFORE PROCEEDING TO NEXT STEPS.
- THE BELOW DIMENSIONS ARE CRITICAL TO THE FINAL ROOF ASSEMBLY.
- MEASUREMENTS SHOULD BE WITHIN $\pm 1/4"$.
- MEASUREMENTS OUTSIDE OF TOLERANCE WILL LEAD TO THE INABILITY TO ASSEMBLE THE ROOF.

ONCE SQUARE, TIGHTEN ALL HARDWARE FROM PREVIOUS STEPS

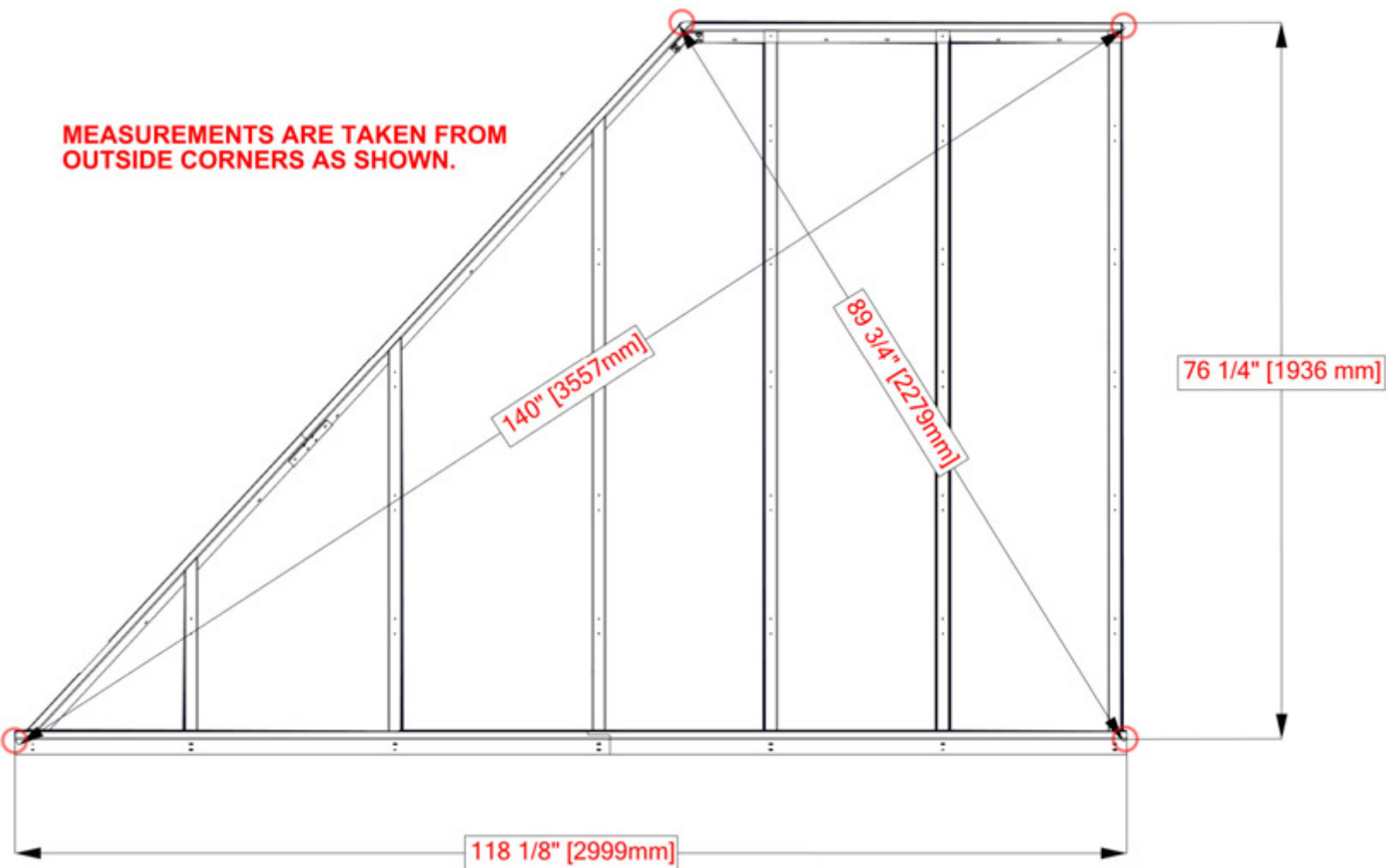

STEP 47 - LEFT PANEL ASSEMBLY

QTY	PART NUMBER	DESCRIPTION
26	H100391	SCREW PFH 8x2 BLK

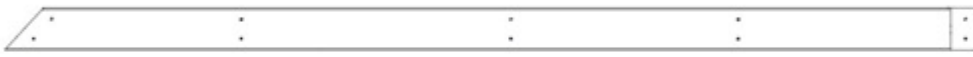

H23 PURLIN - W4L17559
(x1) 15/16"x3 3/8"x78 3/8" (24x86x1991)



H24 PURLIN - W4L17560
(x1) 15/16"x3 3/8"x20 9/16" (24x86x522)



H21 PURLIN - W4L17557
(x1) 15/16"x3 3/8"x72 1/4" (24x86x1835)

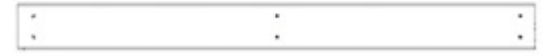

H22 PURLIN - W4L17558
(x1) 15/16"x3 3/8"x38 13/16" (24x86x986)

- TIPS:**
- ALIGN PURLIN PILOT HOLES WITH RAFTER PILOT HOLES.
 - ATTACH SCREWS FROM THE CENTER AND WORK OUTWARD.
 - H18 BOARD DOES NOT HAVE PILOT HOLES FOR OUTSIDE EDGE SCREWS.
 - USING THE PURLINS AS A GUIDE AND A 1/8" DRILL BIT, DRILL PILOT HOLES INTO H18 BOARD.

OVERHANG END OF PURLIN 3/8" FROM EDGE OF RAFTER

391 (x26)
SCREW - 2"

OUTSIDE EDGE SCREWS

3/8"
[10mm]

5/8"
[15mm]

IF PURLINS OVERHANG MORE THAN 5/8", CUT DOWN TO 5/8"

H23 (x1)
PURLIN

H24 (x1)
PURLIN

H18
RAFTER

H22 (x1)
PURLIN

H21 (x1)
PURLIN

STEP 48 - LEFT PANEL ASSEMBLY

QTY	PART NUMBER	DESCRIPTION
3	H100200	SCREW PFH 8x1 1/2 BLK
31	H100391	SCREW PFH 8x2 BLK

T02 PURLIN - W4L17564
(x1) 15/16"x1 5/16"x49 3/4" (24x34x1264)

H27 PURLIN - W4L17563
(x1) 15/16"x3 3/8"x60 1/4" (24x86x1530)

H26 PURLIN - W4L17562
(x1) 15/16"x3 3/8"x72 3/8" (24x86x1838)

H25 PURLIN - W4L17561
(x1) 15/16"x3 3/8"x84 1/2" (24x86x2147)

TIPS:

- ALIGN PURLIN PILOT HOLES WITH RAFTER PILOT HOLES.
- ATTACH SCREWS FROM THE CENTER AND WORK OUTWARD.
- H19 BOARD DOES NOT HAVE PILOT HOLES FOR OUTSIDE EDGE SCREWS.
- USING THE PURLINS AS A GUIDE AND A 1/8" DRILL BIT, DRILL PILOT HOLES INTO H19 BOARD.

OVERHANG END OF PURLIN 3/8" FROM EDGE OF RAFTER

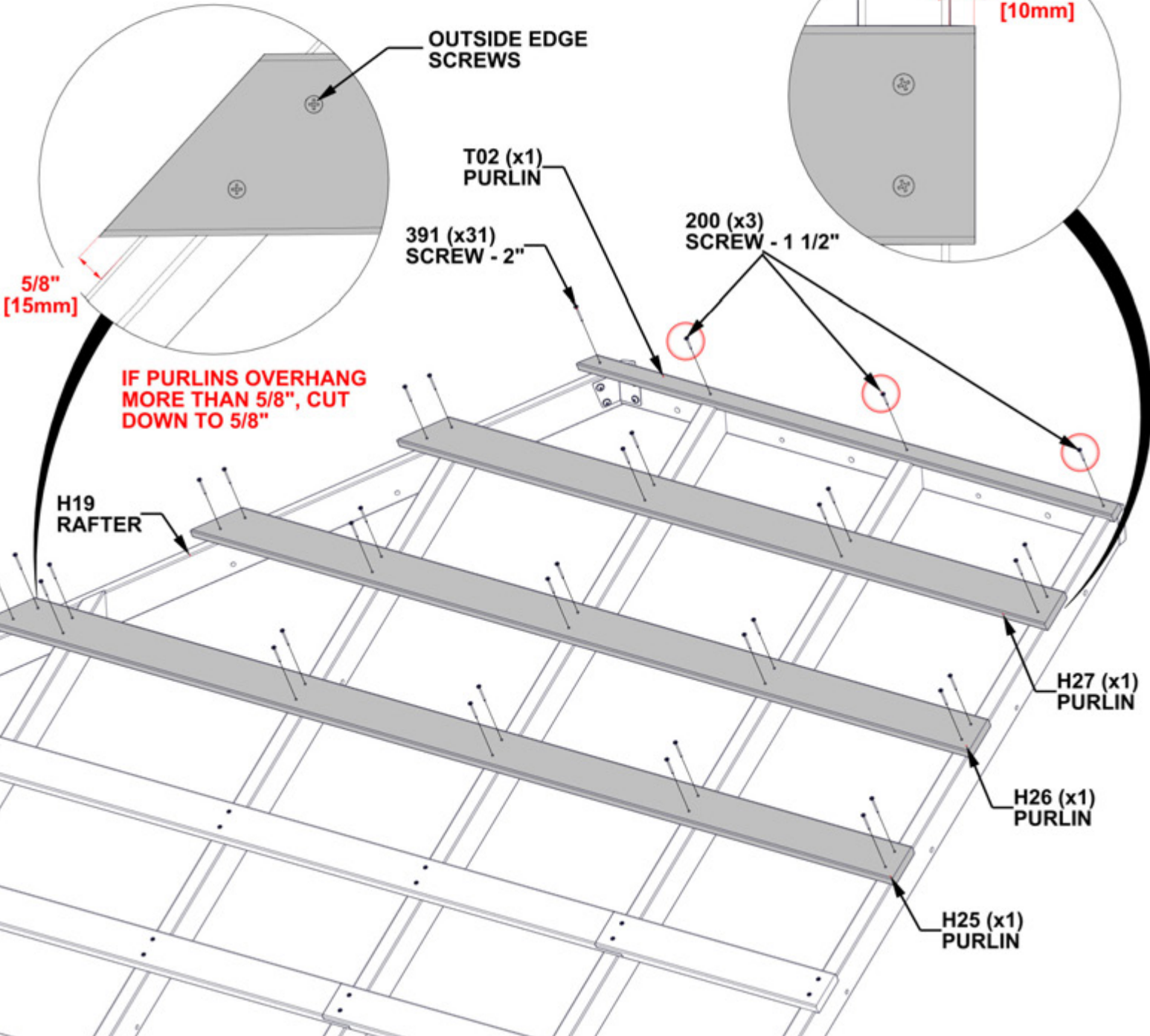

STEP 49 - LEFT PANEL ASSEMBLY

QTY	PART NUMBER	DESCRIPTION
3	H100833	SCREW WOODGRIP 10-16x3/4



A4M02849 RIDGE CAP CHANNEL
(x1)

- TIPS:
- REMOVE PROTECTIVE BLUE FILM.
 - POSITION RIDGE CAP CHANNEL FLUSH WITH ENDS OF PURLINS WITH THE WIDER SIDE OF THE CHANNEL ON THE BOTTOM.
 - MAKE SURE THE BOTTOM EDGE IS AT THE DISTANCE SHOWN BELOW.

WARNING: GLOVES ARE RECOMMENDED WHEN HANDLING STEEL ROOF PIECES

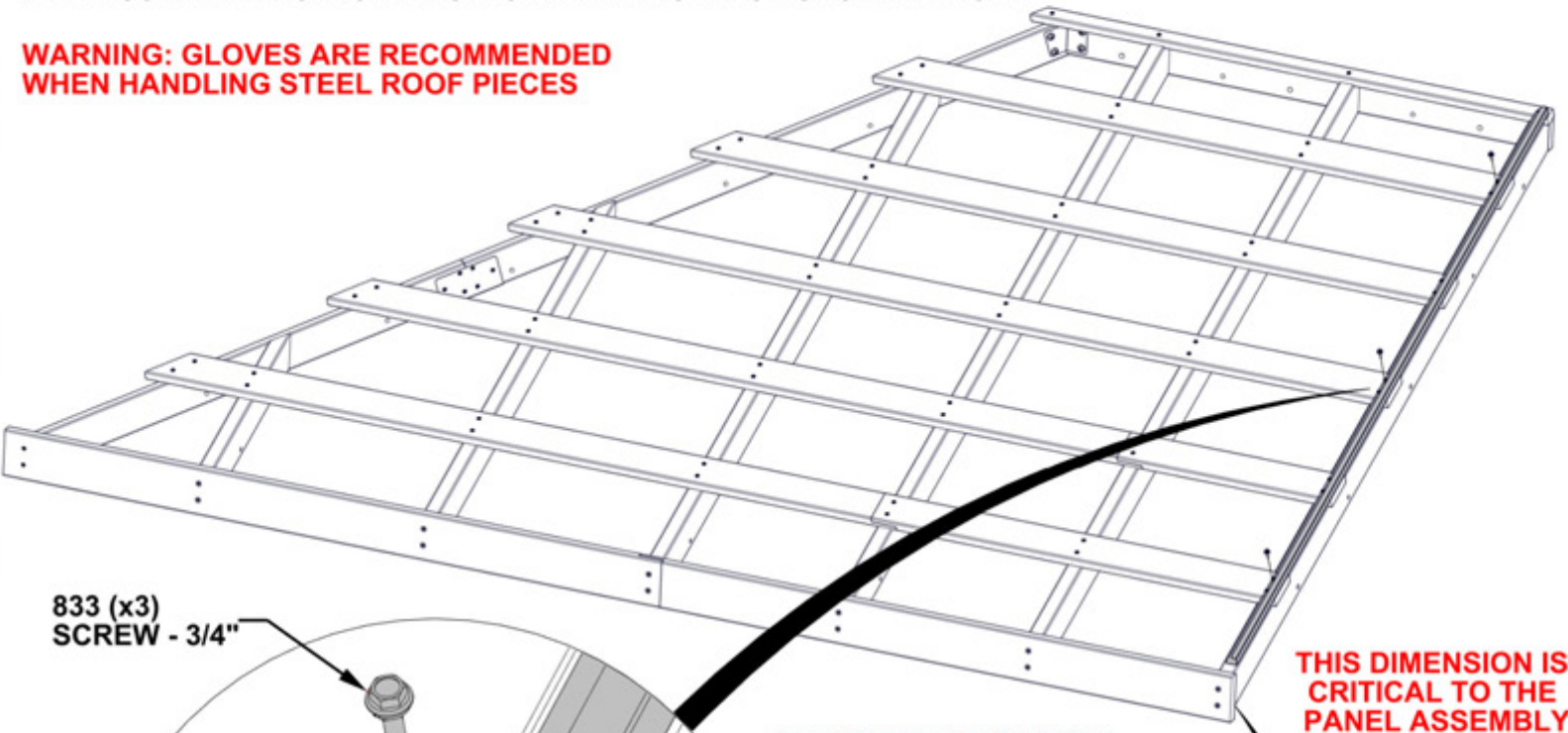

833 (x3)
SCREW - 3/4"

FLUSH RIDGE CHANNEL WITH ENDS OF PURLINS

THIS DIMENSION IS CRITICAL TO THE PANEL ASSEMBLY

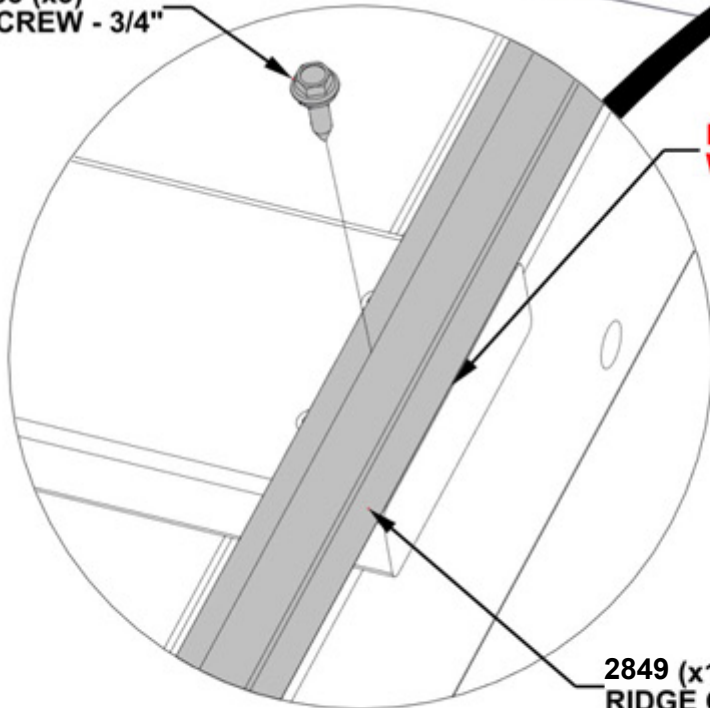

2849 (x1)
RIDGE CAP CHANNEL

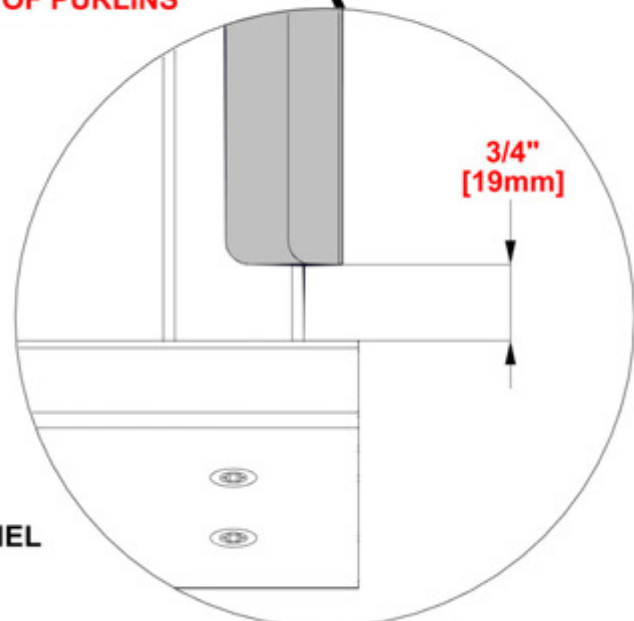

3/4"
[19mm]

TOP VIEW

STEP 50 - LEFT PANEL ASSEMBLY

QTY	PART NUMBER	DESCRIPTION
23	H100833	SCREW WOODGRIP 10-16x3/4

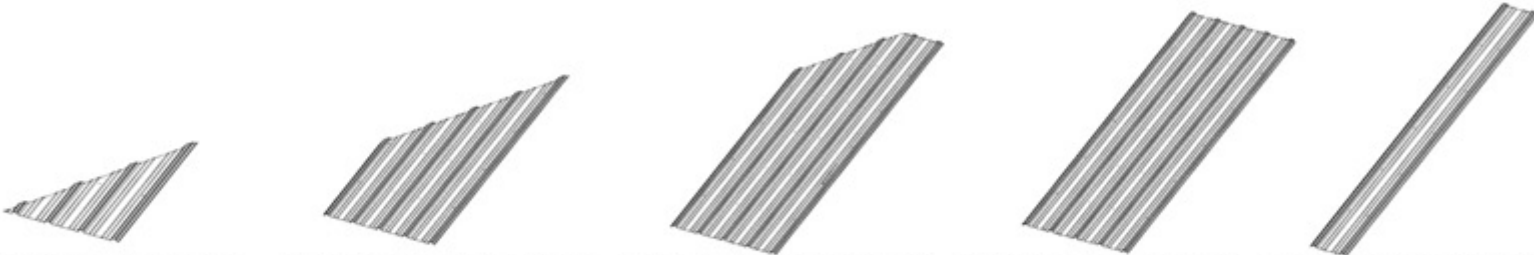

AM402817-1 29GA STEEL SHEETING (x1) A4M02816-1 29GA STEEL SHEETING (x1) A4M02815-1 29GA STEEL SHEETING (x1) A4M02818 29GA STEEL SHEETING (x1) A4M02819 29GA STEEL SHEETING (x1)

- TIPS:**
- REMOVE PROTECTIVE BLUE FILM.
 - OVERLAP PANELS BY ONE RIDGE.
 - PANELS SHOULD BE FLUSH WITH PURLIN ENDS AND Q03 ROOF FASCIA.
 - ONCE SHEETING IS IN PLACE, IT IS RECOMMENDED TO ADD H100833 SCREWS IN THE MIDDLE OF THE SHEETS TO HOLD SHEETING FOR THE NEXT STEP.

WARNING: GLOVES ARE RECOMMENDED WHEN HANDLING STEEL ROOF PIECES

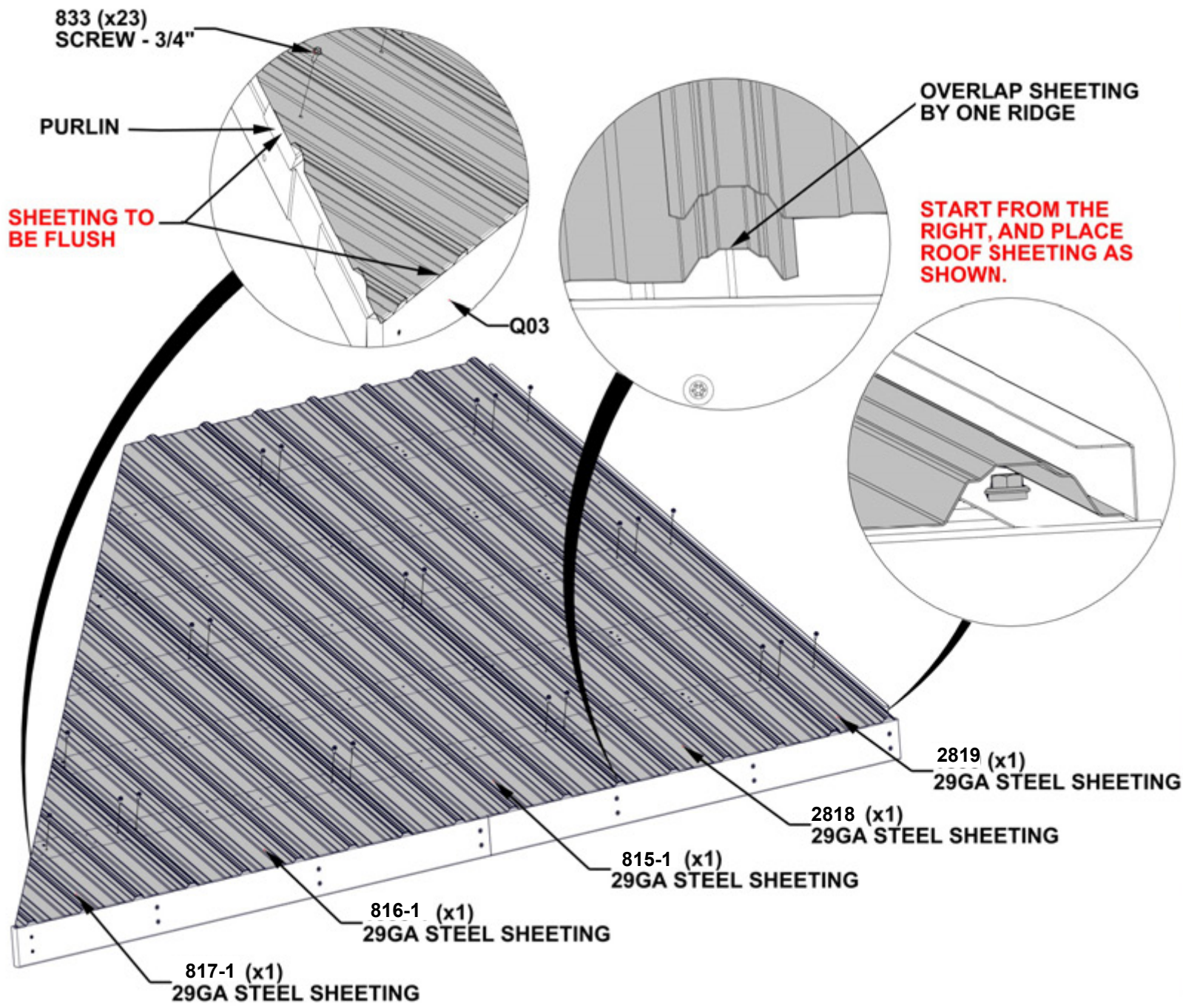

STEP 51 - LEFT PANEL ASSEMBLY

QTY	PART NUMBER	DESCRIPTION
5	H100833	SCREW WOODGRIP 10-16x3/4



TIPS:

- REMOVE PROTECTIVE BLUE FILM.
- POSITION THE RIDGE CAP CHANNEL OVER THE EDGE OF THE ROOF SHEETING WITH THE WIDER SIDE OF THE CHANNEL ON THE BOTTOM.
- MAKE SURE THE SHEETING IS FULLY SEATED INTO THE CHANNEL.

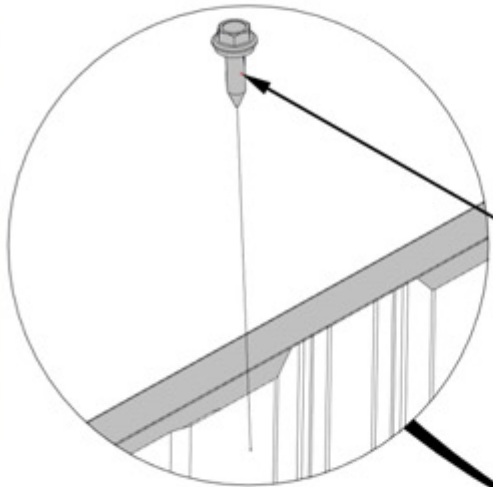

833 (x5)
SCREW - 3/4"

2847(x1)
RIDGE CAP
CHANNEL LONG

2850(x1)
RIDGE CAP
CHANNEL SHORT

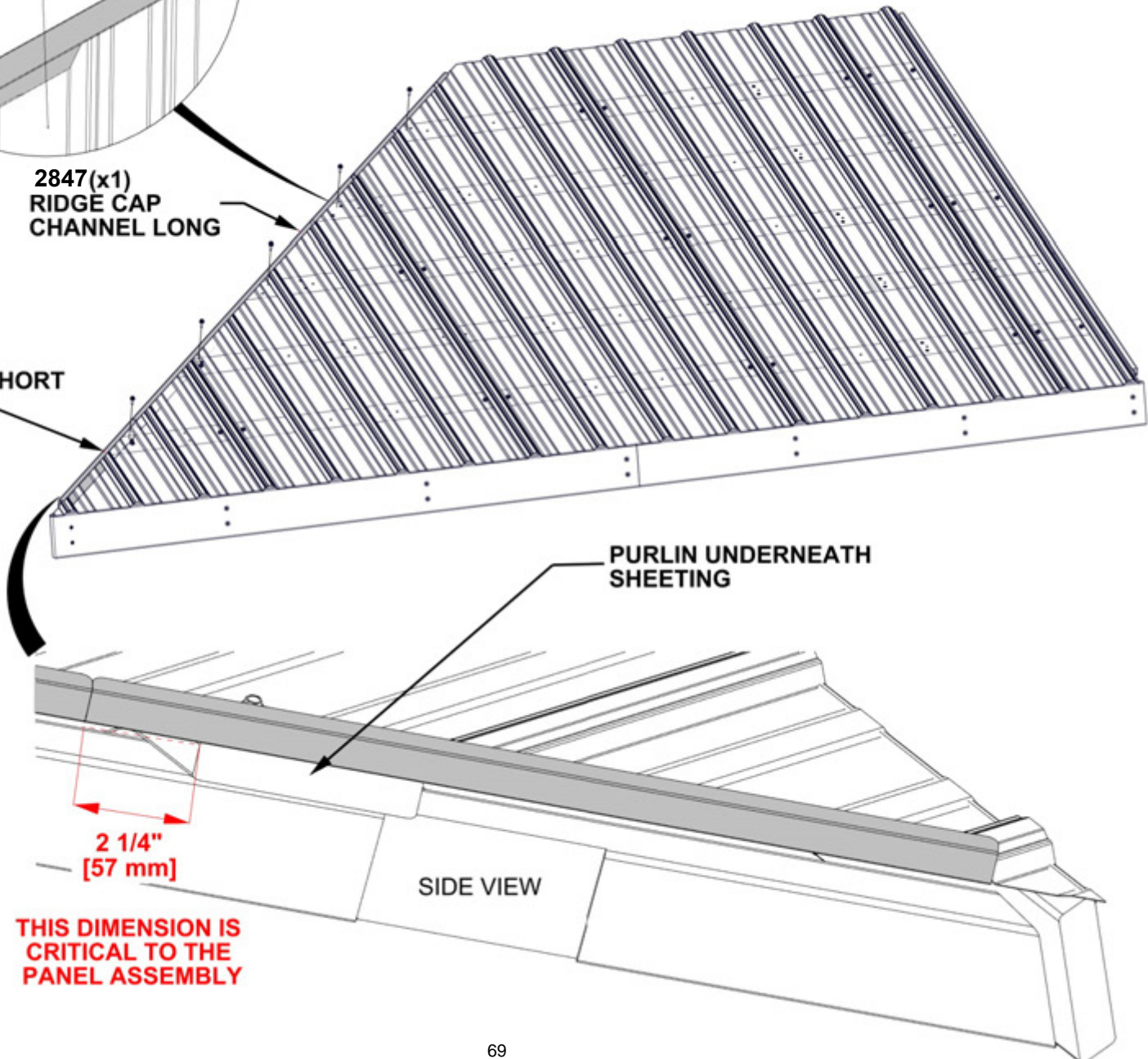

THIS DIMENSION IS CRITICAL TO THE PANEL ASSEMBLY

STEP 52 - LEFT PANEL ASSEMBLY

QTY	PART NUMBER	DESCRIPTION
39	H100833	SCREW WOODGRIP 10-16x3/4

TIPS:

- INSERT REMAINING SCREWS TO FASTEN SHEET METAL IN PLACE.
- MAKE SURE SHEET EDGES ARE FLUSH AS SHOWN.

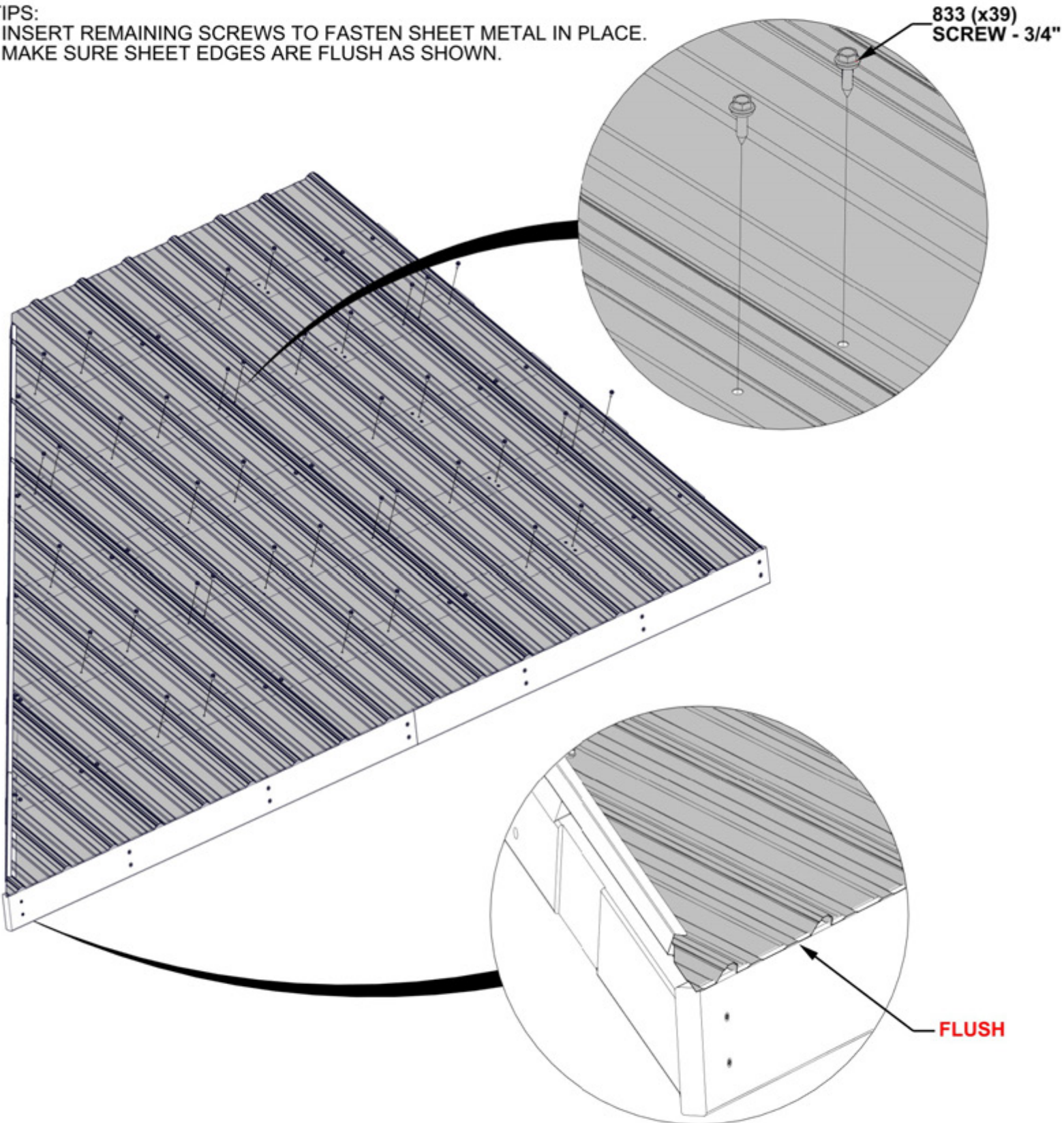

**REPEAT LEFT PANEL ASSEMBLY
STEPS 39 THROUGH 52.**

STEP 53 - RIGHT PANEL ASSEMBLY

QTY	PART NUMBER	DESCRIPTION
2	H100171	BOLT WH 1/4x1 BLK
2	H100398	TNUT-1/4" BLK



H30 RAFTER SUPPORT - W4L17570
(x1) 15/16"x3 3/8"x46 3/8" (24x86x1177)



A4M01193 PANEL BRACKET
(x1)

**INSERT T-NUTS FIRST
HAND TIGHTEN ONLY**

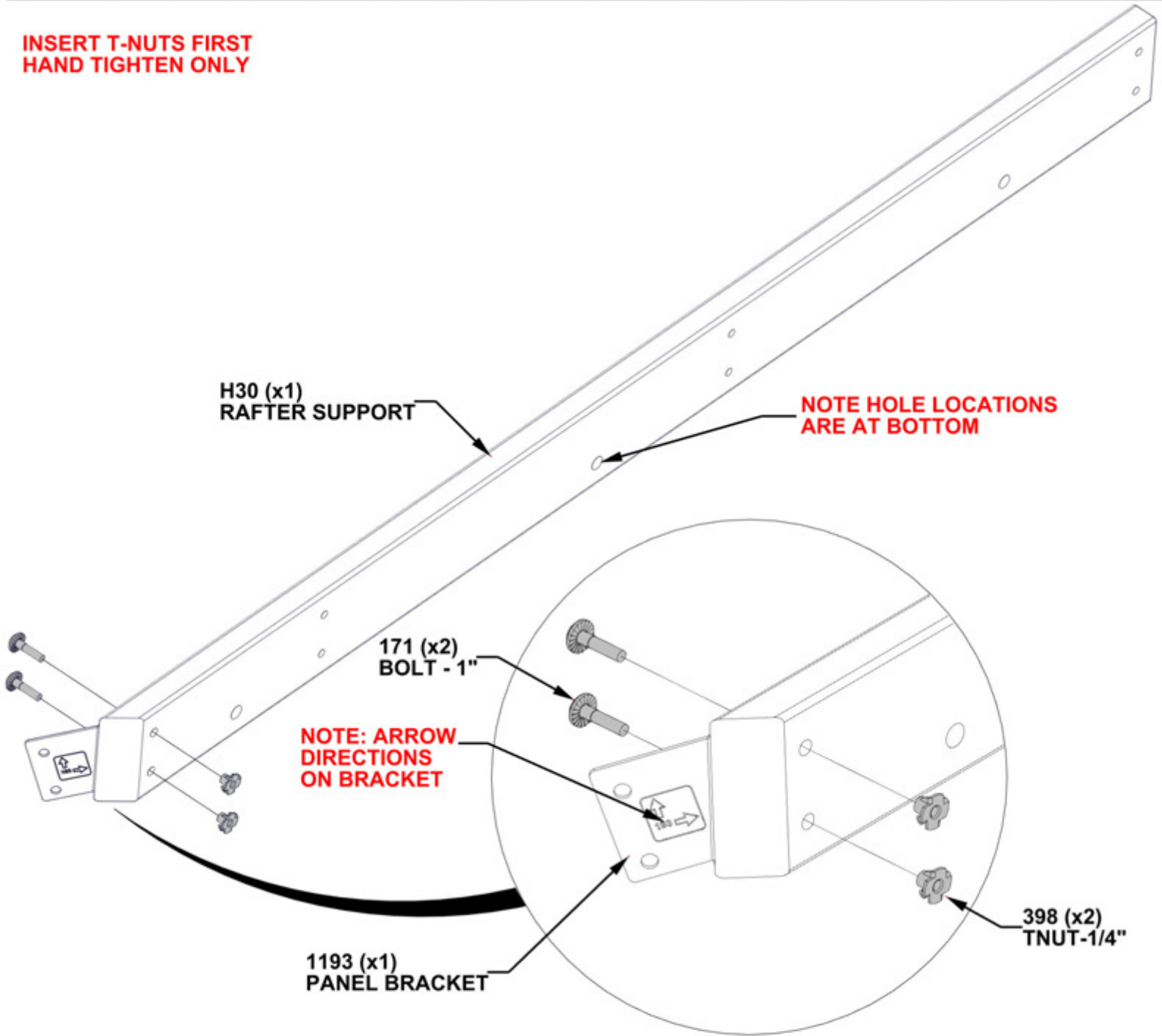

STEP 54 - RIGHT PANEL ASSEMBLY

QTY	PART NUMBER	DESCRIPTION
2	H100398	TNUT-1/4" BLK
12	H100385	SCREW PFH 8x1 BLK



H28 RAFTER - W4L17568
(x1) 15/16"x3 3/8"x44 1/2" (24x86x1130)



A4M01237 ROOF SUPPORT SPLICE CLIP
(x1)



H29 RAFTER - W4L17569
(x1) 15/16"x3 3/8"x60 5/8" (24x86x1540)

INSERT T-NUTS FIRST

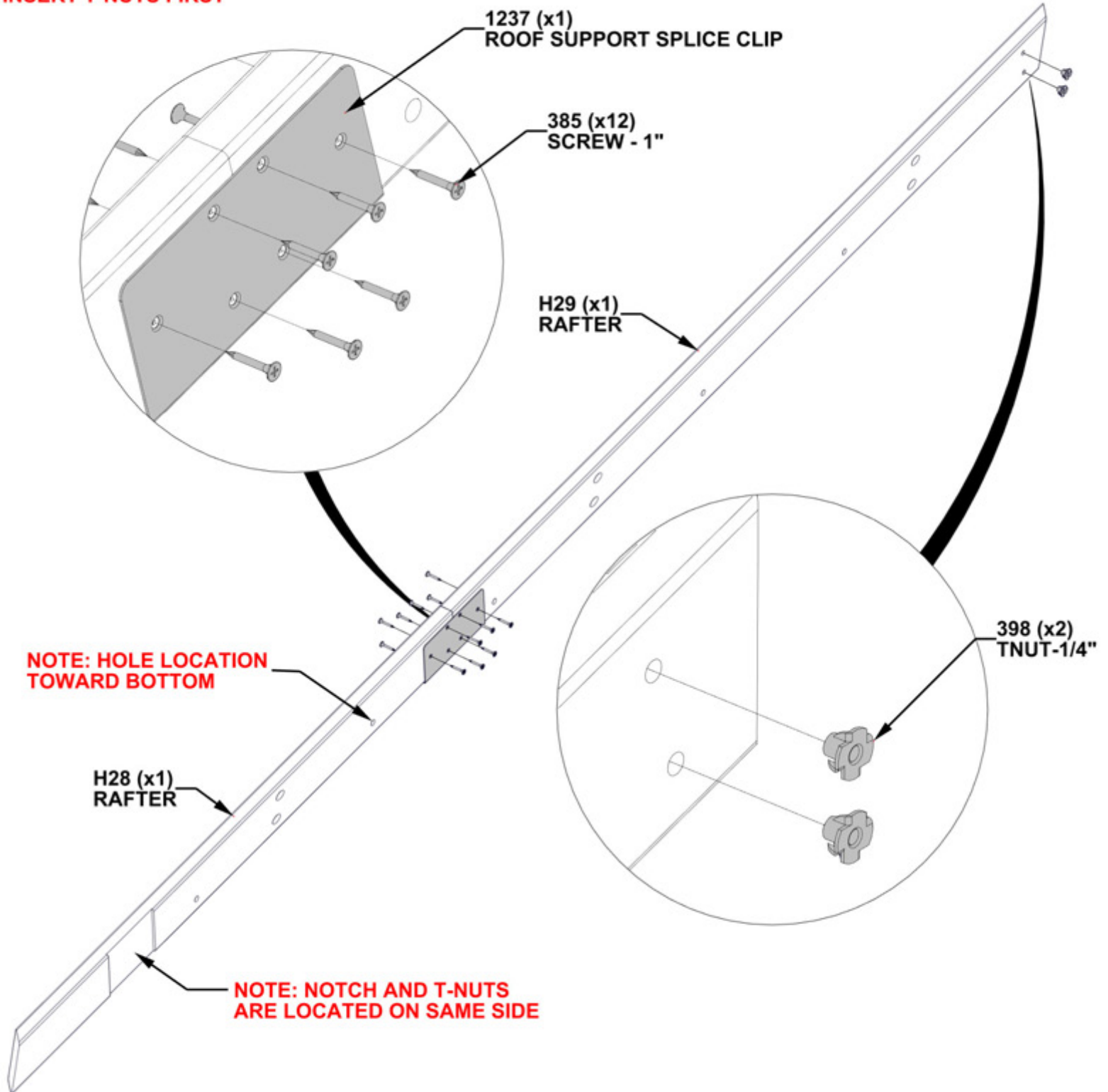

STEP 55 - RIGHT PANEL ASSEMBLY

QTY	PART NUMBER	DESCRIPTION
2	H100171	BOLT WH 1/4x1 BLK



H28/H29 RAFTER ASSEMBLY
FROM PREVIOUS STEP

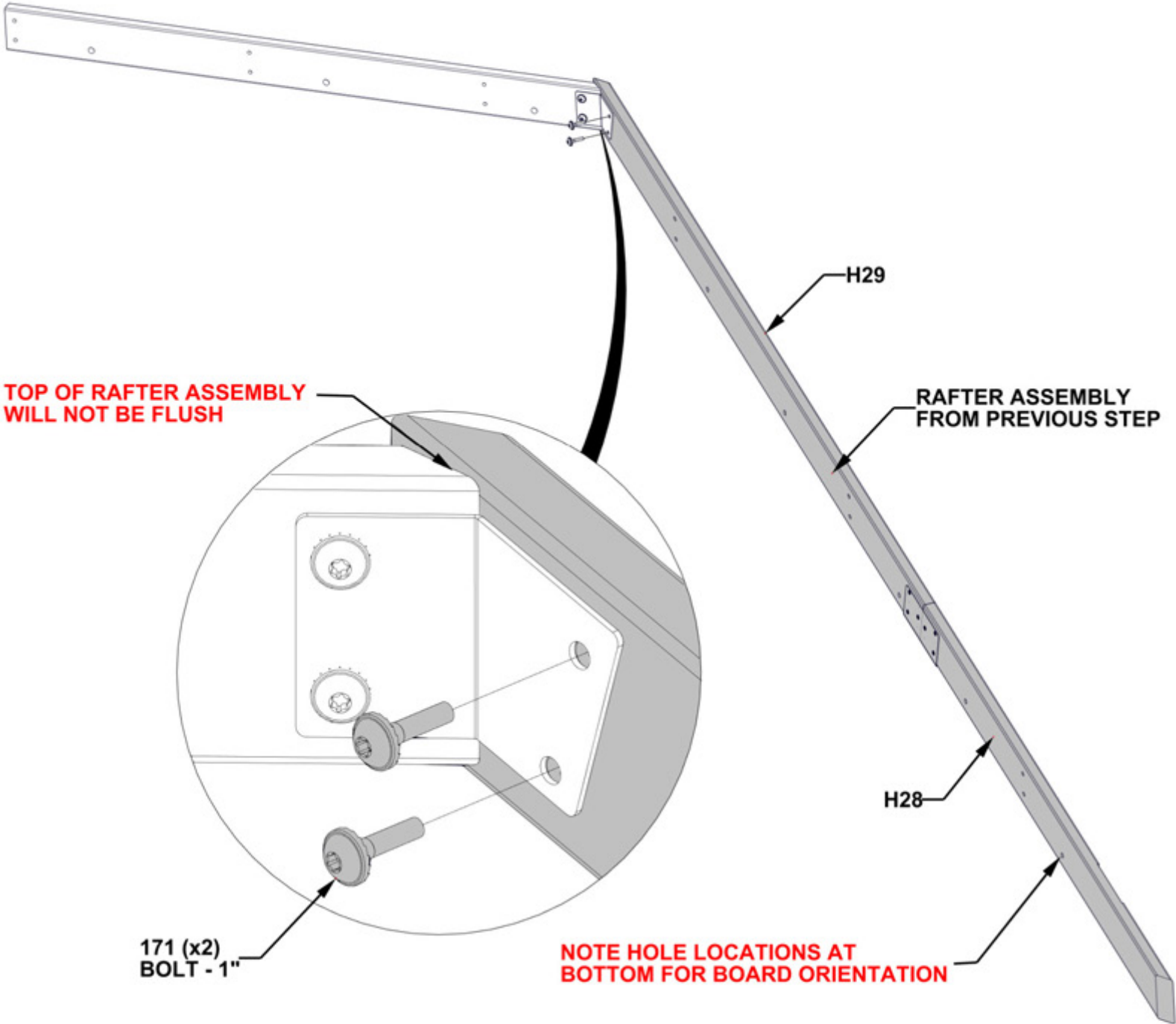

STEP 56 - RIGHT PANEL ASSEMBLY

QTY	PART NUMBER	DESCRIPTION
6	H101030	SCREW CONFIRMAT 7x2 BLK



E16 RAFTER - W4L17572
(x1) 1 7/16"x76 1/8"x3 3/8" (36x86x1934)

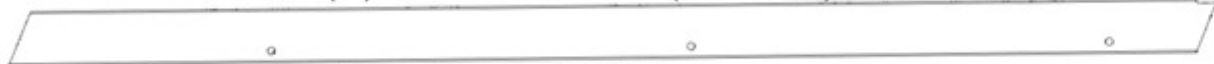

E15 RAFTER - W4L17571
(x1) 1 7/16"x3 3/8"x76 1/8" (36x86x1934)



E08 RAFTER - W4L17552
(x1) 1 7/16"x3 3/8"x76 1/8" (36x86x1934)

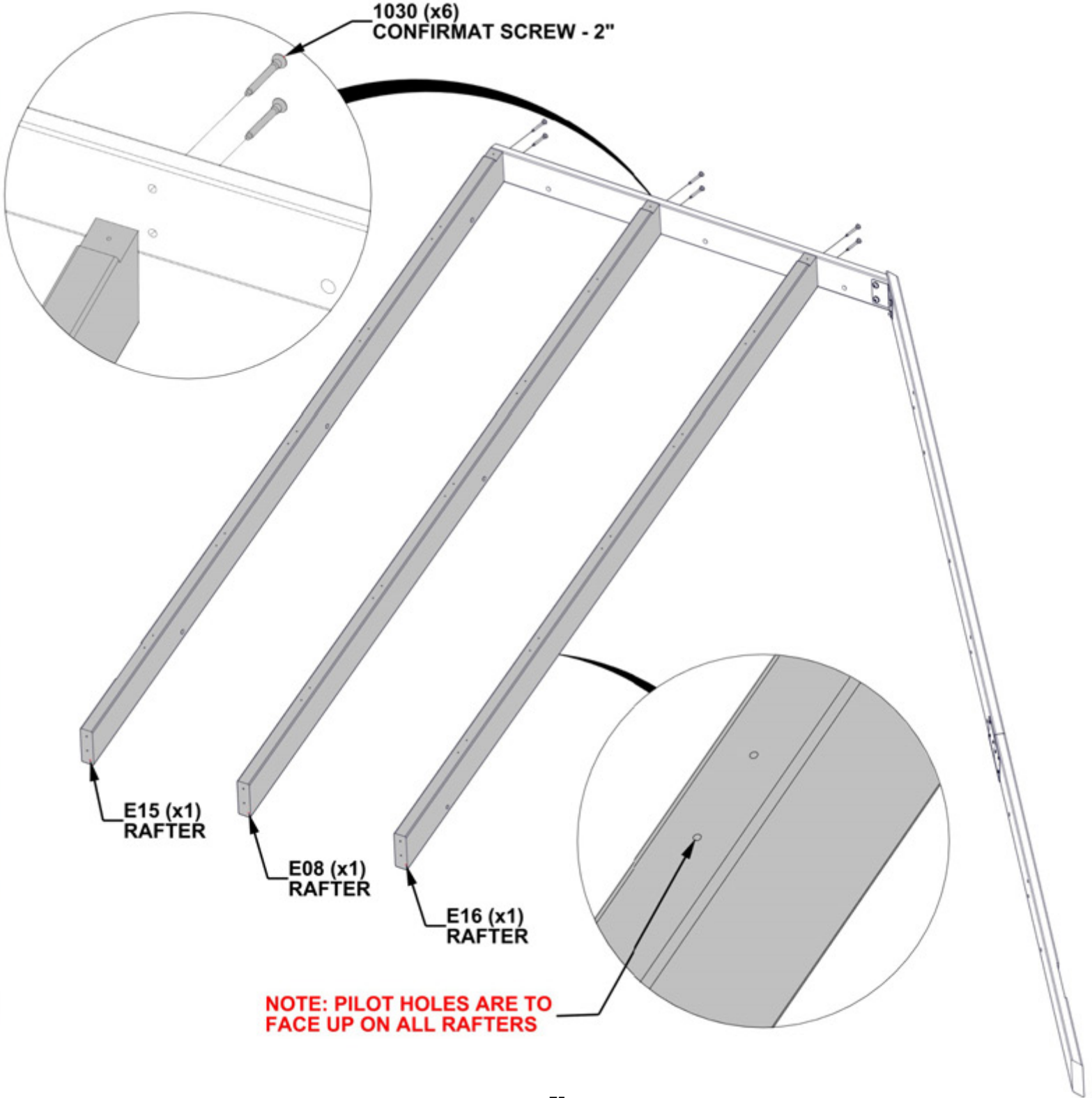

STEP 57 - RIGHT PANEL ASSEMBLY

QTY	PART NUMBER	DESCRIPTION
6	H101030	SCREW CONFIRMAT 7x2 BLK



E12 RAFTER - W4L17565
(x1) 3 3/8"x1 7/16"x20 3/16" (36x86x512)



E13 RAFTER - W4L17566
(x1) 1 7/16"x3 3/8"x43 5/8" (36x86x1109)



E14 RAFTER - W4L17567
(x1) 1 7/16"x3 3/8"x67 1/8" (36x86x1705)

1030 (x6)
CONFIRMAT SCREW - 2"

**NOTE: PILOT HOLES
ARE TO FACE UP
ON ALL RAFTERS**

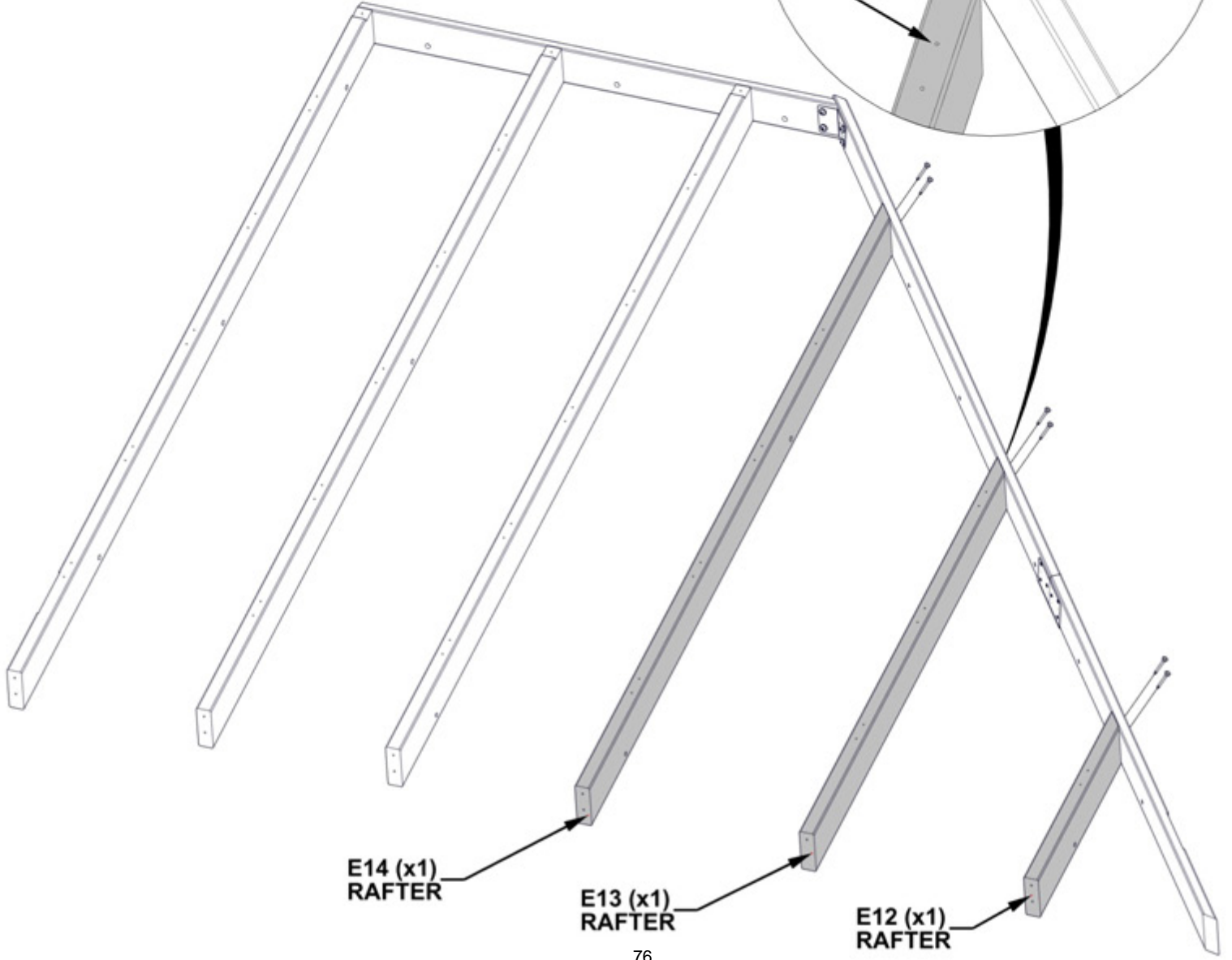
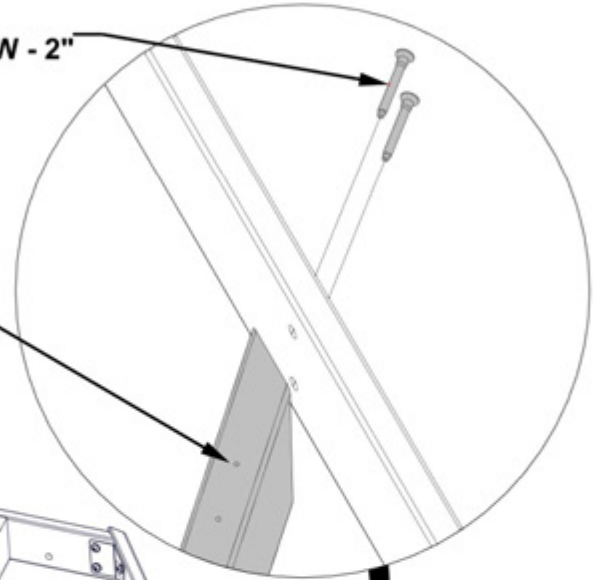

STEP 58 - RIGHT PANEL ASSEMBLY

QTY	PART NUMBER	DESCRIPTION
12	H101030	SCREW CONFIRMAT 7x2 BLK



Q03 FASCIA - W4L17550
(x1) 15/16"x4 7/16"x63 3/16" (24x112x1605)



Q04 FASCIA - W4L17556
(x1) 15/16"x4 7/16"x57 1/4" (24x112x1454)

START AT LEFT RAFTER AND WORK TOWARDS THE RIGHT, OVERHANGING END AS SHOWN

TIP: RAFTER MAY NEED TO BE LOOSENED UP TO ATTACH FASCIA BOARDS

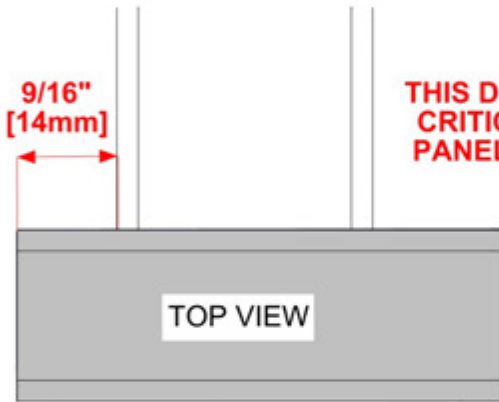

THIS DIMENSION IS CRITICAL TO THE PANEL ASSEMBLY

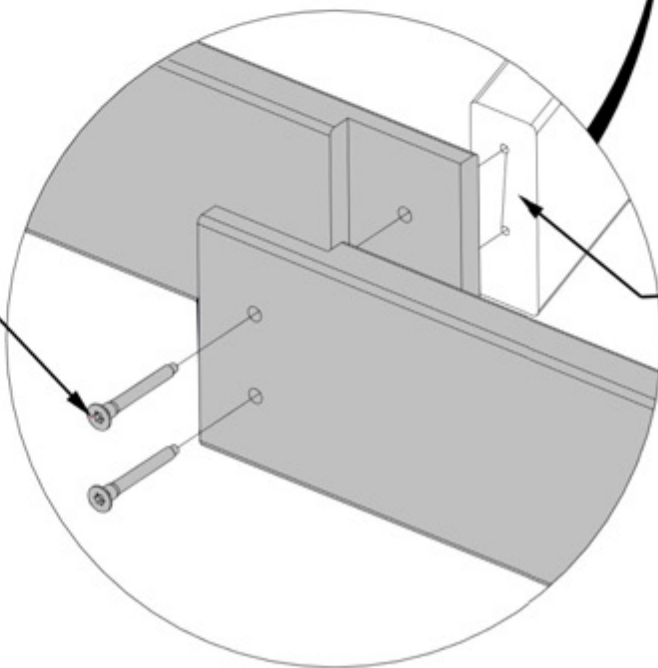
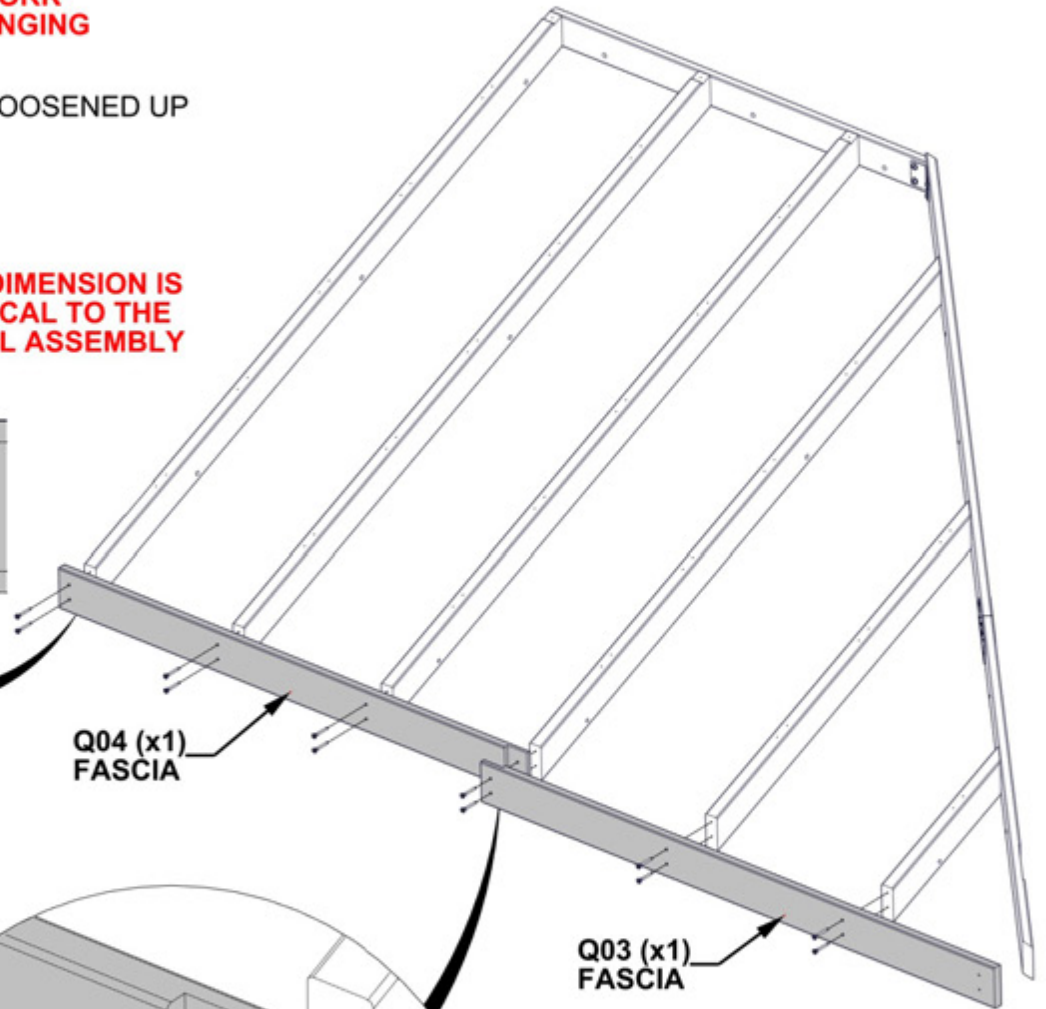

NOTE: ALIGN FASCIA WITH PILOT HOLES IN ENDS OF RAFTERS

STEP 59 - RIGHT PANEL ASSEMBLY

QTY	PART NUMBER	DESCRIPTION
2	H100382	SCREW PFH 8x1 3/4 BLK

TIPS:

- USING THE Q03 BOARD AS A GUIDE AND A 1/8" DRILL BIT, DRILL PILOT HOLES INTO THE H28 BOARD USING THE DIMENSION BELOW.

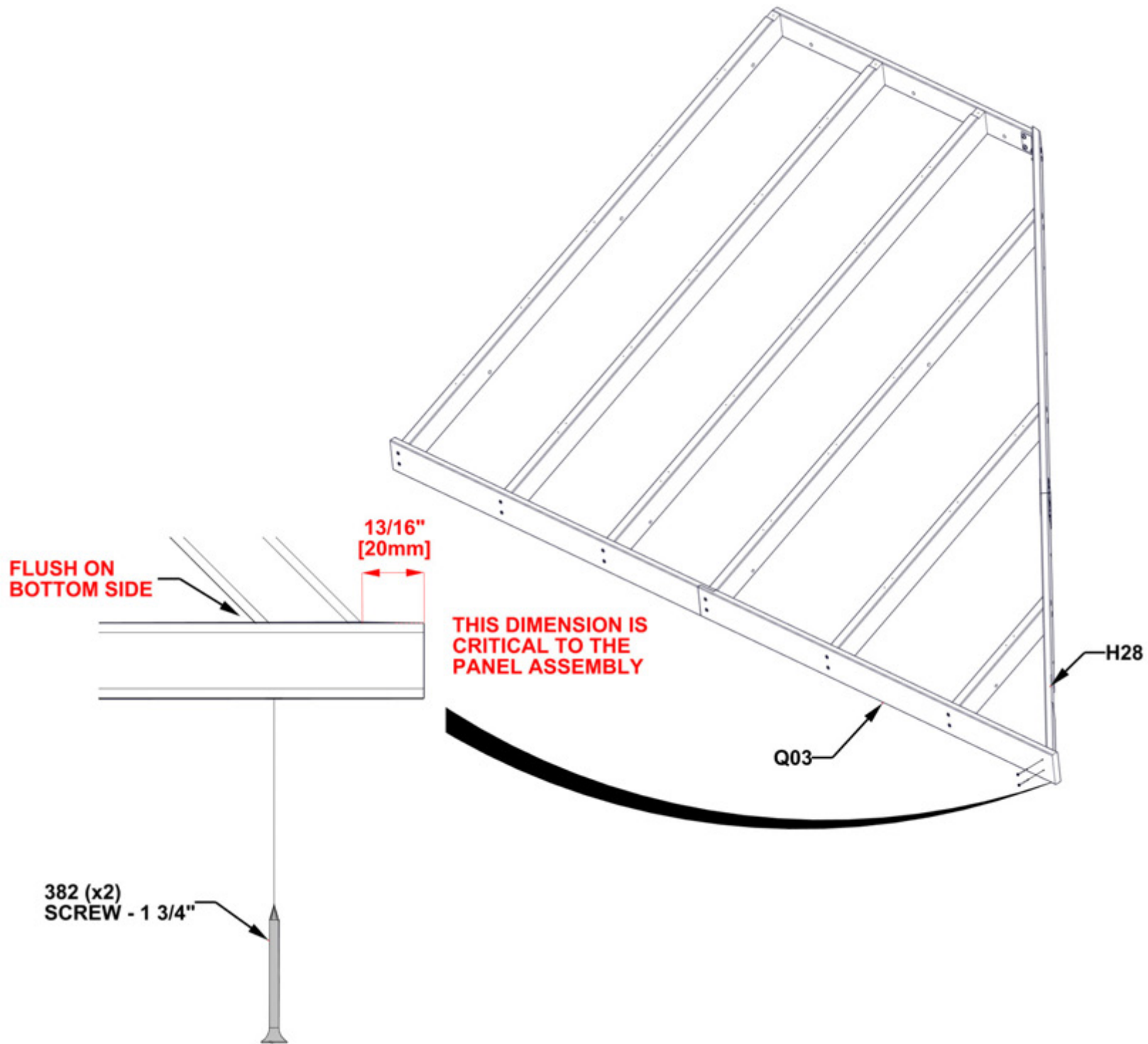

STEP 60 - RIGHT PANEL ASSEMBLY

TIP: LOOSEN HARDWARE TO ADJUST FOR SQUARING IF NEEDED.

CRITICAL:

- SQUARE UNIT BEFORE PROCEEDING TO NEXT STEPS.
- THE BELOW DIMENSIONS ARE CRITICAL TO THE FINAL ROOF ASSEMBLY.
- MEASUREMENTS SHOULD BE WITHIN +/- 1/4".
- MEASUREMENTS OUTSIDE OF TOLERANCE WILL LEAD TO THE INABILITY TO ASSEMBLE THE ROOF.

ONCE SQUARE, TIGHTEN ALL HARDWARE FROM PREVIOUS STEPS

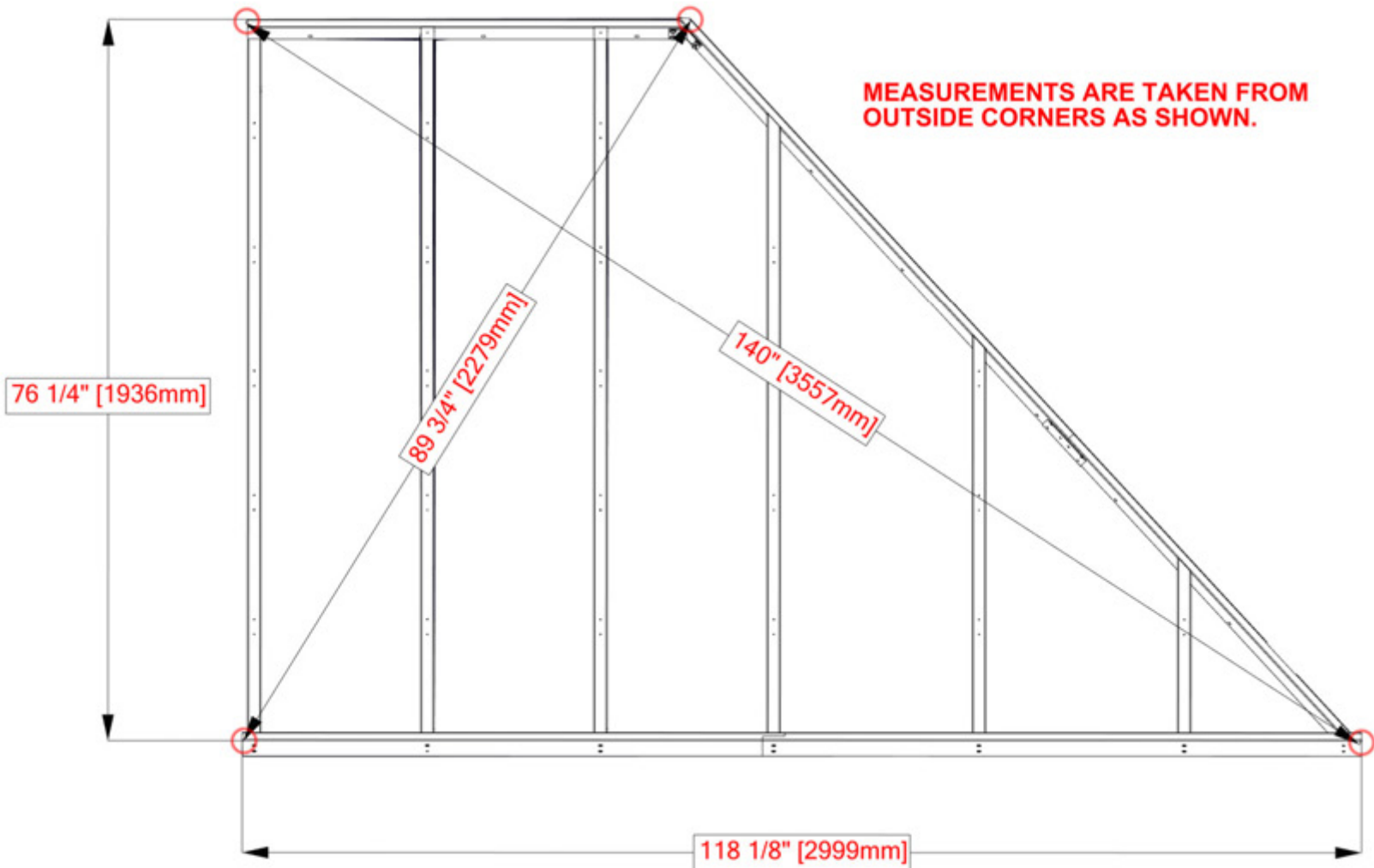

STEP 61 - RIGHT PANEL ASSEMBLY

QTY	PART NUMBER	DESCRIPTION
26	H100391	SCREW PFH 8x2 BLK



H23 PURLIN - W4L17559
(x1) 15/16"x3 3/8"x78 3/8" (24x86x1991)



H24 PURLIN - W4L17560
(x1) 15/16"x3 3/8"x20 9/16" (24x86x522)



H21 PURLIN - W4L17557
(x1) 15/16"x3 3/8"x72 1/4" (24x86x1835)



H22 PURLIN - W4L17558
(x1) 15/16"x3 3/8"x38 13/16" (24x86x986)

- TIPS:
- ALIGN PURLIN PILOT HOLES WITH RAFTER PILOT HOLES.
 - ATTACH SCREWS FROM THE CENTER AND WORK OUTWARD.
 - H28 BOARD DOES NOT HAVE PILOT HOLES FOR OUTSIDE EDGE SCREWS.
 - USING THE PURLINS AS A GUIDE AND A 1/8" DRILL BIT, DRILL PILOT HOLES INTO H28 BOARD.

IF PURLINS OVERHANG MORE THAN 5/8", CUT DOWN TO 5/8"

OVERHANG END OF PURLIN 3/8" FROM EDGE OF RAFTER

391 (x26) SCREW - 2"

OUTSIDE EDGE SCREWS

3/8" [10mm]

5/8" [15mm]

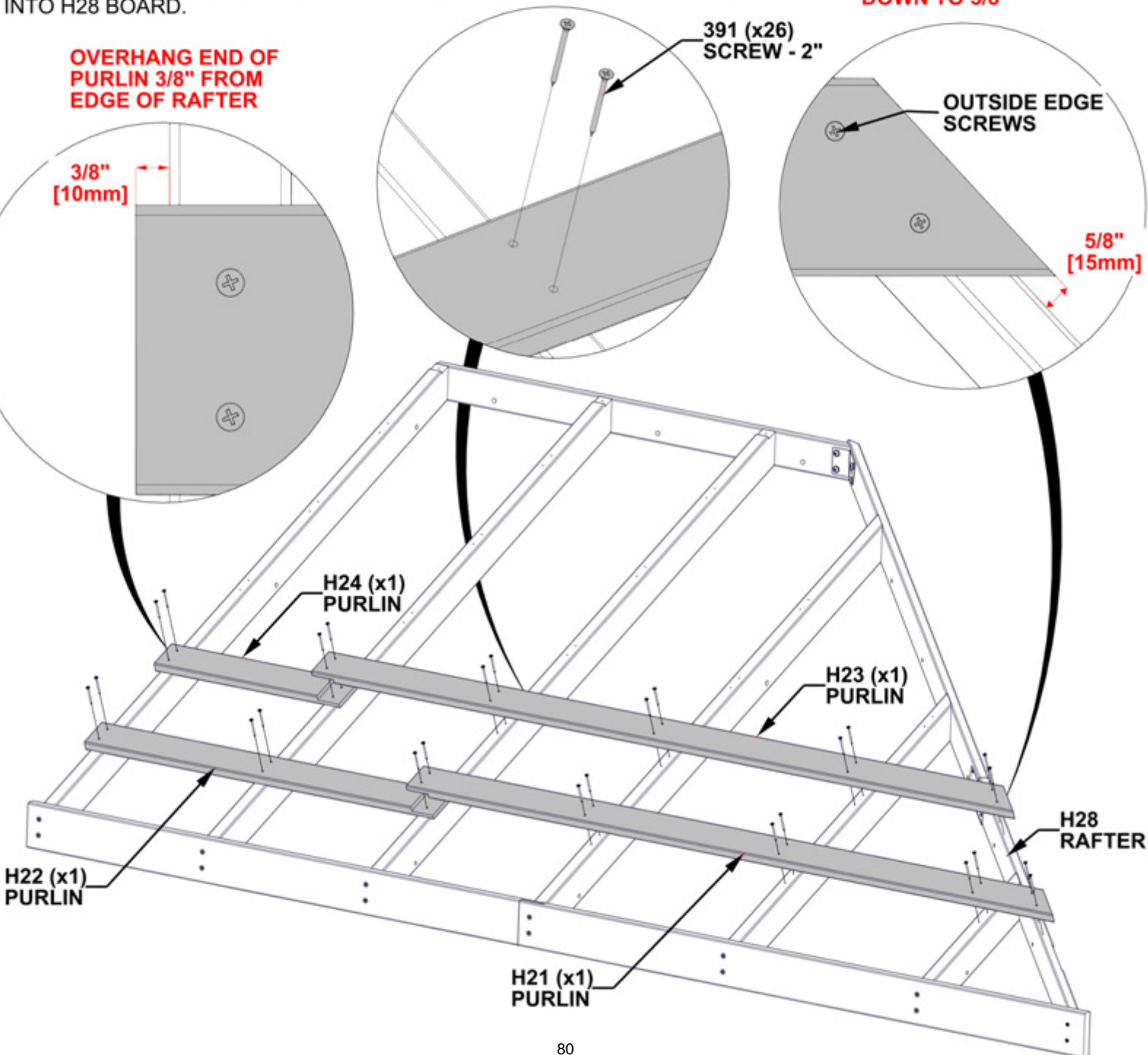

STEP 62 - RIGHT PANEL ASSEMBLY

QTY	PART NUMBER	DESCRIPTION
3	H100200	SCREW PFH 8x1 1/2 BLK
31	H100391	SCREW PFH 8x2 BLK

T02 PURLIN - W4L17564
(x1) 15/16"x1 5/16"x49 3/4" (24x34x1264)

H27 PURLIN - W4L17563
(x1) 15/16"x3 3/8"x60 1/4" (24x86x1530)

H26 PURLIN - W4L17562
(x1) 15/16"x3 3/8"x72 3/8" (24x86x1838)

H25 PURLIN - W4L17561
(x1) 15/16"x3 3/8"x84 1/2" (24x86x2147)

TIPS:

- ALIGN PURLIN PILOT HOLES WITH RAFTER PILOT HOLES.
- ATTACH SCREWS FROM THE CENTER AND WORK OUTWARD.
- H29 BOARD DOES NOT HAVE PILOT HOLES FOR OUTSIDE EDGE SCREWS.
- USING THE PURLINS AS A GUIDE AND A 1/8" DRILL BIT, DRILL PILOT HOLES INTO H29 BOARD.

IF PURLINS OVERHANG MORE THAN 5/8", CUT DOWN TO 5/8"

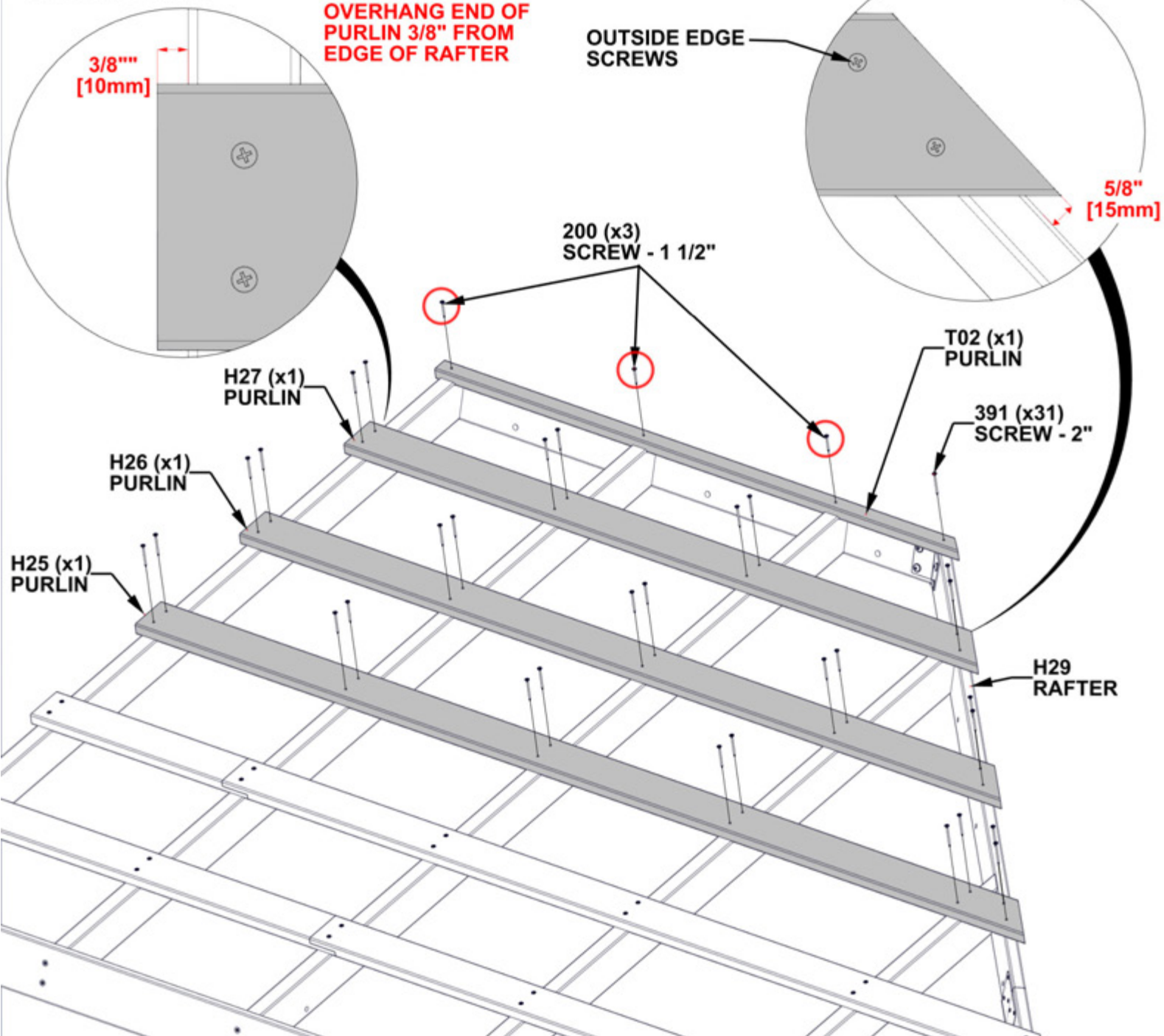

STEP 63 - RIGHT PANEL ASSEMBLY

QTY	PART NUMBER	DESCRIPTION
3	H100833	SCREW WOODGRIP 10-16x3/4



A4M02849 RIDGE CAP CHANNEL
(x1)

TIPS:

- REMOVE PROTECTIVE BLUE FILM.
- POSITION RIDGE CAP CHANNEL FLUSH WITH ENDS OF PURLINS WITH THE WIDER SIDE OF THE CHANNEL ON THE BOTTOM.
- MAKE SURE THE BOTTOM EDGE IS AT THE DISTANCE SHOWN BELOW.

WARNING: GLOVES ARE RECOMMENDED WHEN HANDLING STEEL ROOF PIECES

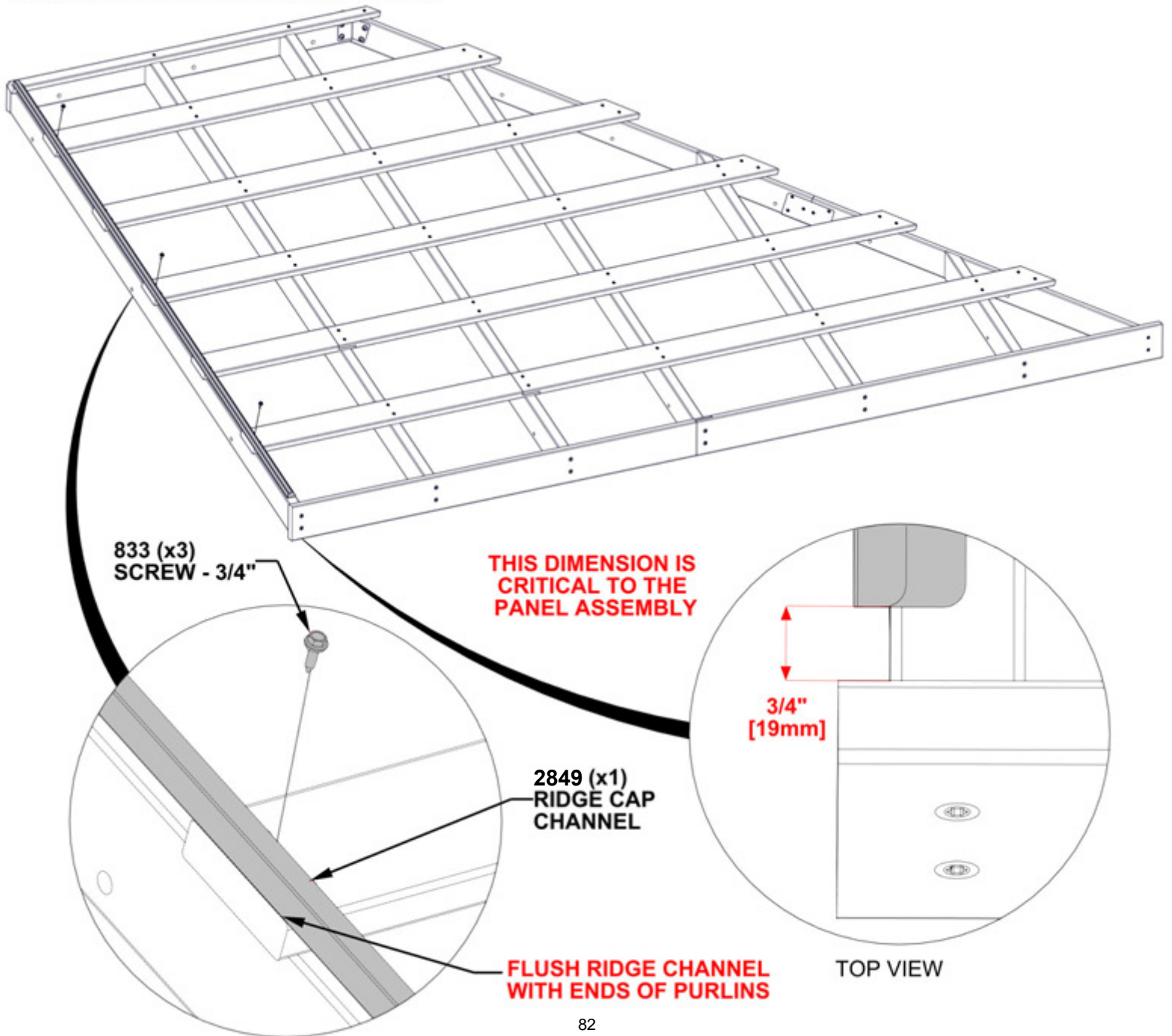

STEP 64 - RIGHT PANEL ASSEMBLY

QTY	PART NUMBER	DESCRIPTION
23	H100833	SCREW WOODGRIP 10-16x3/4

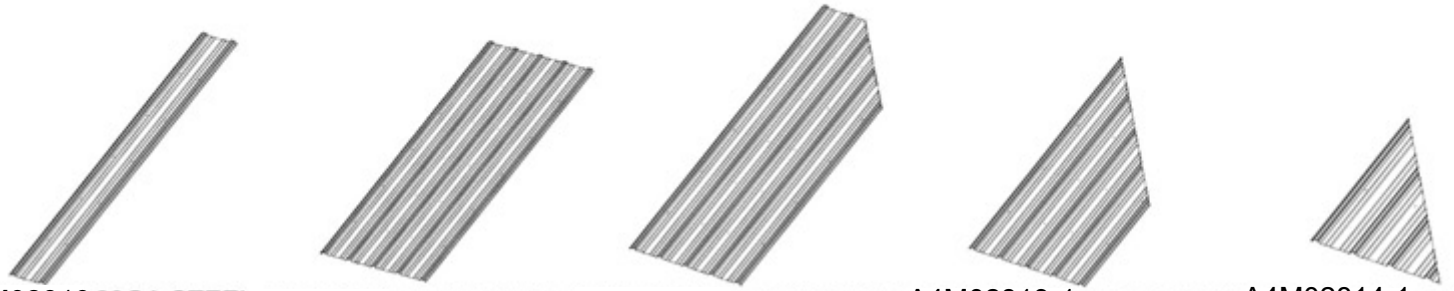

A4M02819 29GA STEEL SHEETING (x1) A4M02818 29GA STEEL SHEETING (x1) A4M02812-1 29GA STEEL SHEETING (x1) A4M02813-1 29GA STEEL SHEETING (x1) A4M02814-1 29GA STEEL SHEETING (x1)

- TIPS:**
- REMOVE PROTECTIVE BLUE FILM.
 - OVERLAP SHEETING BY ONE RIDGE.
 - SHEETING SHOULD BE FLUSH WITH PURLIN ENDS AND Q03 ROOF FASCIA.
 - ONCE SHEETING IS IN PLACE, IT IS RECOMMENDED TO ADD H100833 SCREWS IN THE MIDDLE OF THE SHEETS TO HOLD SHEETING FOR THE NEXT STEP.

WARNING: GLOVES ARE RECOMMENDED WHEN HANDLING STEEL ROOF PIECES

OVERLAP SHEETING BY ONE RIDGE

START FROM THE LEFT, AND PLACE ROOF SHEETING AS SHOWN.

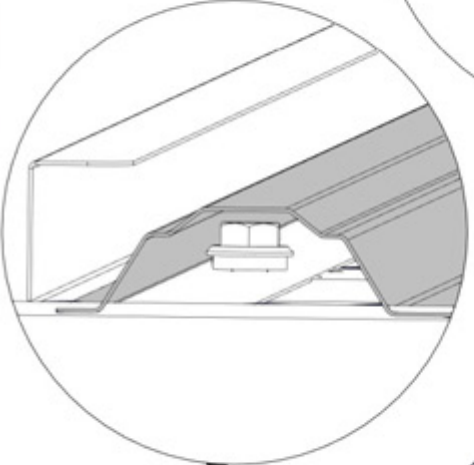
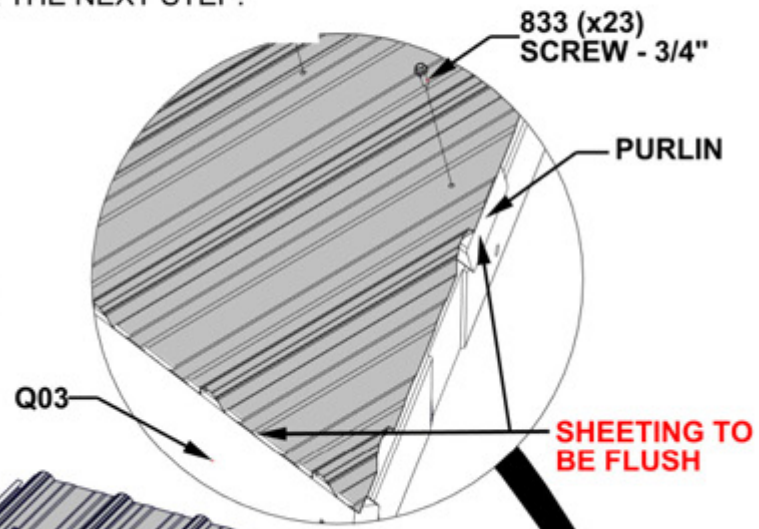

2819 (x1)
29GA STEEL SHEETING

2818 (x1)
29GA STEEL SHEETING

812-1 (x1)
29GA STEEL SHEETING

813-1 (x1)
29GA STEEL SHEETING

814-1 (x1)
29GA STEEL SHEETING

STEP 65 - RIGHT PANEL ASSEMBLY

QTY	PART NUMBER	DESCRIPTION
5	H100833	SCREW WOODGRIP 10-16x3/4



- TIPS:**
- POSITION THE RIDGE CAP CHANNEL OVER THE EDGE OF THE ROOF PANELS WITH THE WIDER SIDE OF THE CHANNEL ON THE BOTTOM.
 - MAKE SURE THE PANELS ARE FULLY SEATED INTO THE CHANNEL.

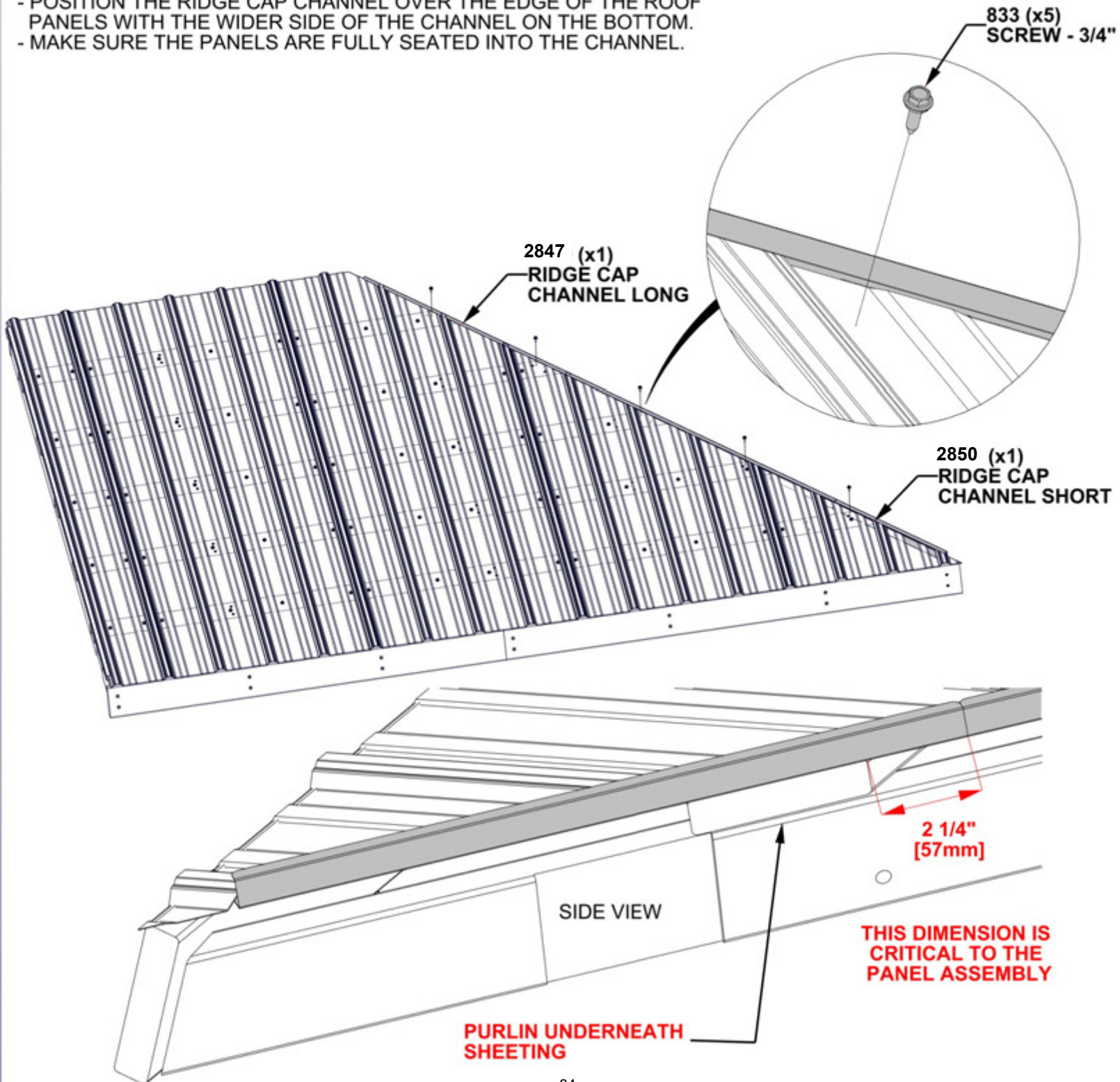

STEP 66 - RIGHT PANEL ASSEMBLY

QTY	PART NUMBER	DESCRIPTION
39	H100833	SCREW WOODGRIP 10-16x3/4

TIPS:

- INSERT REMAINING SCREWS TO FASTEN SHEET METAL IN PLACE.
- MAKE SURE SHEET EDGES ARE FLUSH AS SHOWN.

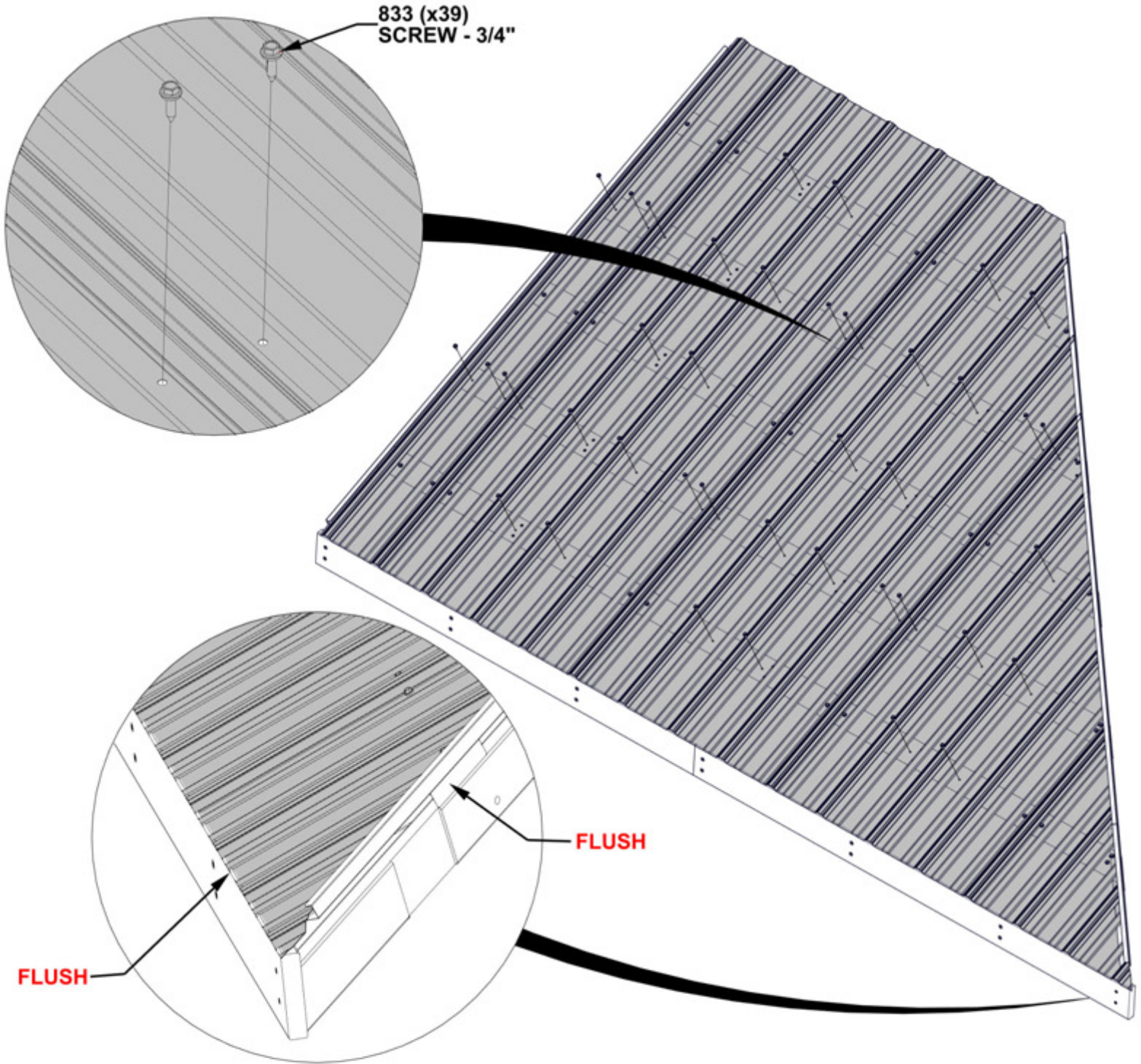

**REPEAT RIGHT PANEL ASSEMBLY
STEPS 53 THROUGH 66.**

STEP 67 - 12FT ROOF PANEL ATTACHMENT

TIPS:

- THREE PEOPLE ARE HELPFUL FOR THIS STEP.
- POSITION A PERSON ON A LADDER IN THE CENTER OF THE GAZEBO TO HELP SUPPORT THE ROOF PANEL.
- WITH TWO PEOPLE, WORK THE PANEL UP WITHOUT SLIDING OR DRAGGING, UNTIL IT MEETS THE ROOF SUPPORT FRAME.
- MAKE SURE THE ROOF PANEL SLIDES UNDERNEATH THE RIDGE CAP.

WARNING: GLOVES ARE RECOMMENDED WHEN HANDLING STEEL ROOF PIECES

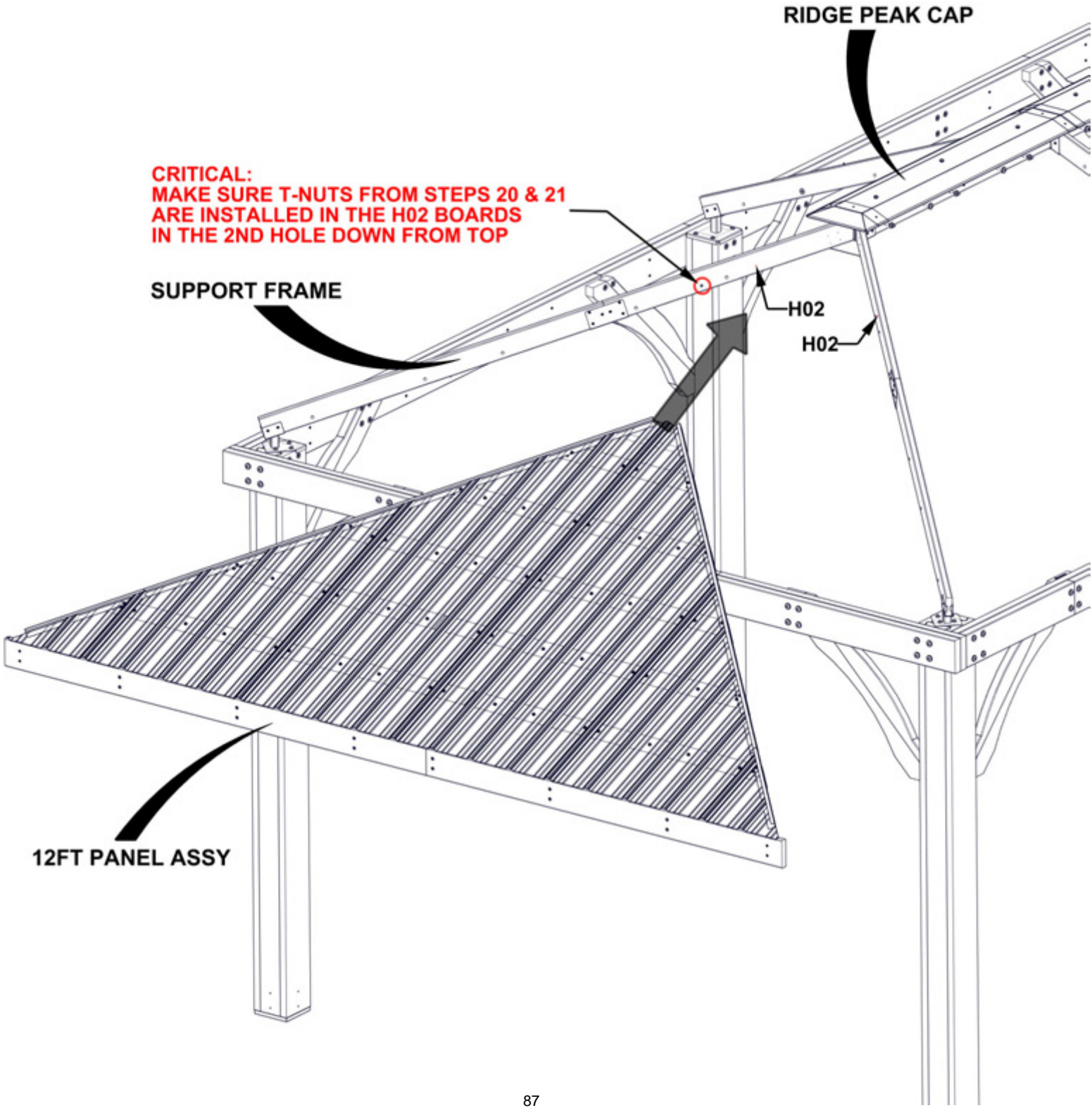

STEP 68 - 12FT ROOF PANEL ATTACHMENT

QTY	PART NUMBER	DESCRIPTION
2	H100378	BOLT WH 5/16x1 3/4 BLK
2	H100198	WASHER LOCK EXT 8x19

- TIPS:
- IF NECESSARY, USE A CLAMP TO HOLD PANELS IN PLACE.
 - INSERT BOLTS INTO THE SECOND HOLE FROM THE TOP OF THE H07/H09 BOARDS.

HAND TIGHTEN ONLY

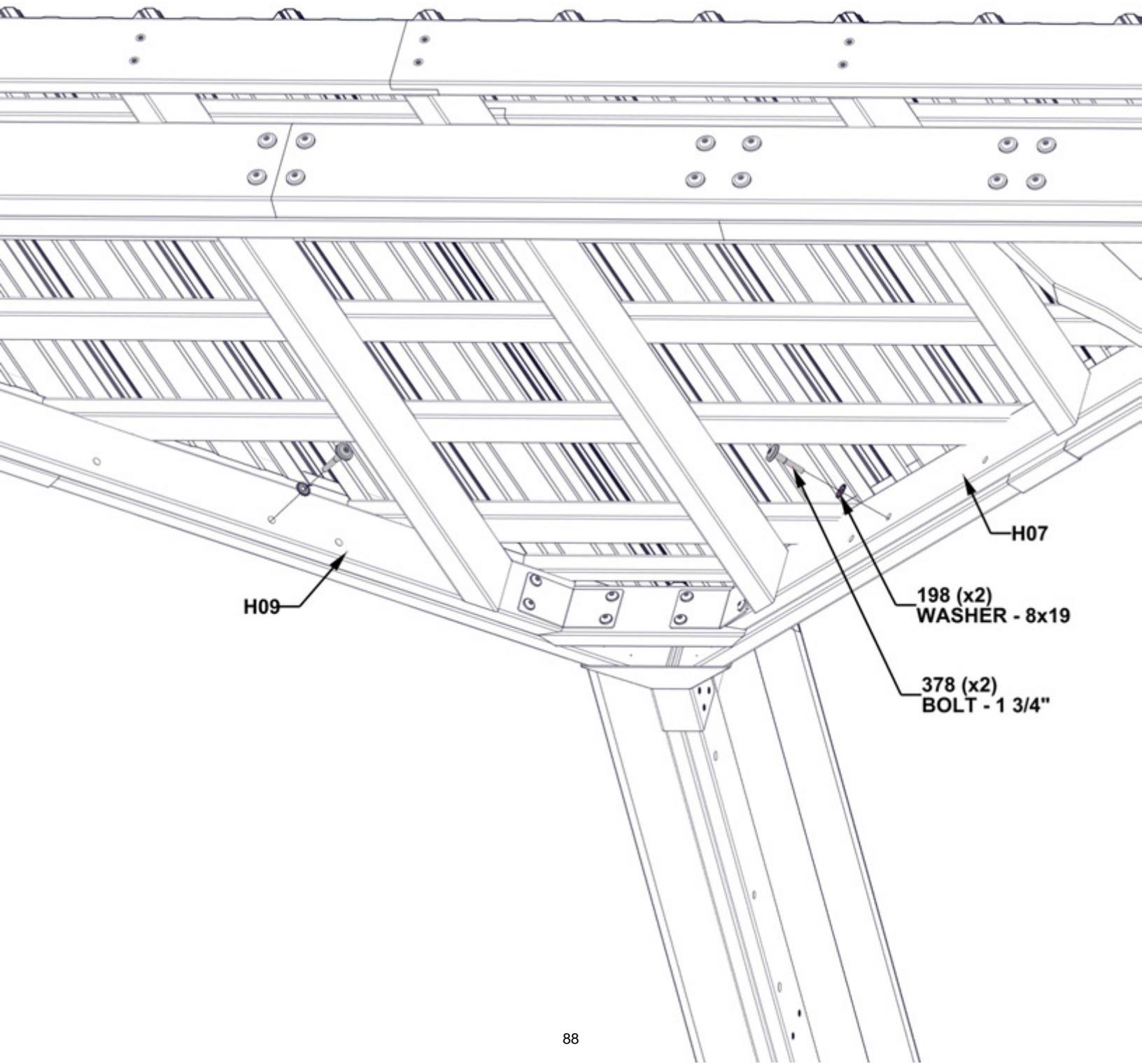

**REPEAT 12FT ROOF PANEL
INSTALLATION STEPS 67 & 68**

STEP 69 - LEFT ROOF PANEL ATTACHMENT

TIPS:

- THREE PEOPLE ARE HELPFUL FOR THIS STEP.
- POSITION A PERSON ON A LADDER IN THE CENTER OF THE GAZEBO TO HELP SUPPORT THE ROOF PANEL.
- WITH TWO PEOPLE, WORK THE PANEL UP WITHOUT SLIDING OR DRAGGING, UNTIL IT MEETS THE ROOF SUPPORT FRAME.
- MAKE SURE THE ROOF PANEL SLIDES UNDERNEATH THE RIDGE CAP.

WARNING: GLOVES ARE RECOMMENDED WHEN HANDLING STEEL ROOF PIECES

CRITICAL:

MAKE SURE T-NUTS FROM STEP 18 AND 26 ARE INSTALLED IN THE ROOF SUPPORT ASSEMBLY AND H05 RAFTER.

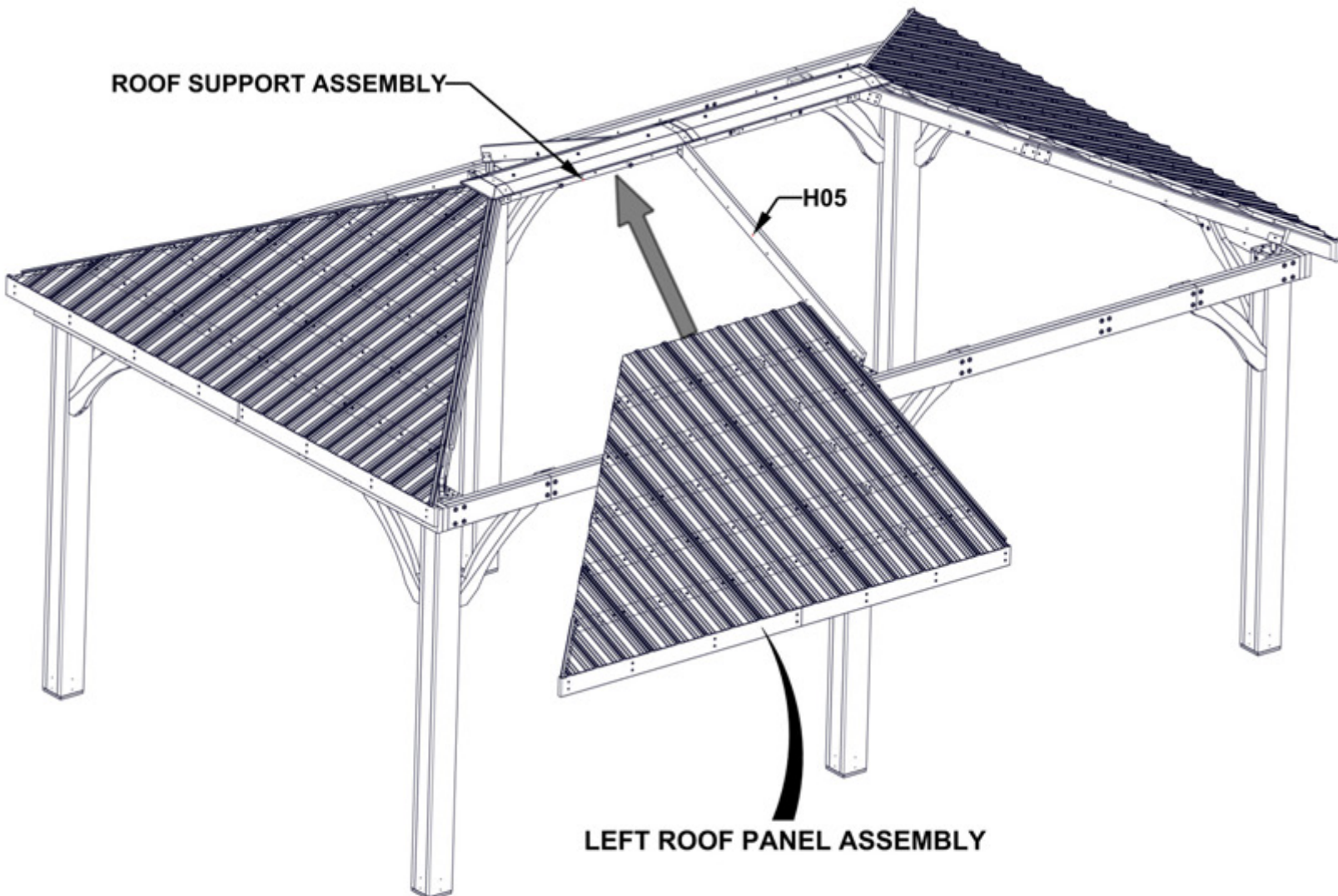

STEP 70 - LEFT ROOF PANEL ATTACHMENT

QTY	PART NUMBER	DESCRIPTION
2	H100195	BOLT WH 5/16x2 3/4 BLK
2	H100205	BOLT WH 5/16x2 1/4 BLK
4	H100198	WASHER LOCK EXT 8x19

TIPS:
 - IF NECESSARY, USE A CLAMP TO HOLD PANELS IN PLACE.

HAND TIGHTEN ONLY

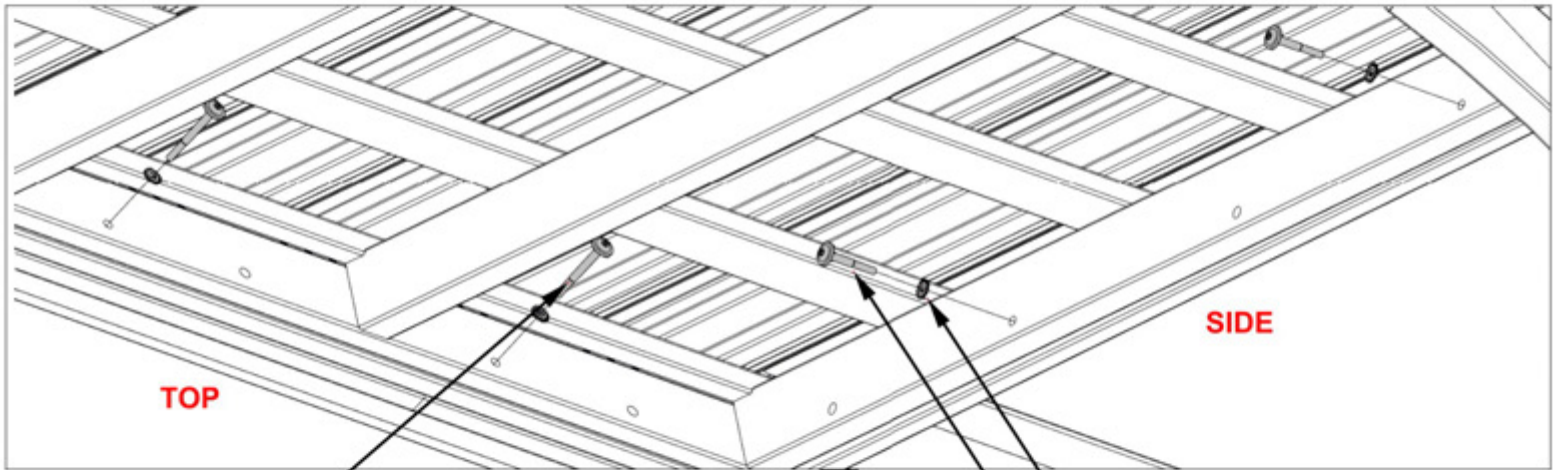

195 (x2)
 BOLT-2 3/4"

198 (x4)
 WASHER - 8x19

NOTE HARDWARE LOCATION AND BOLT CALLOUTS

205 (x2)
 BOLT - 2 1/4"

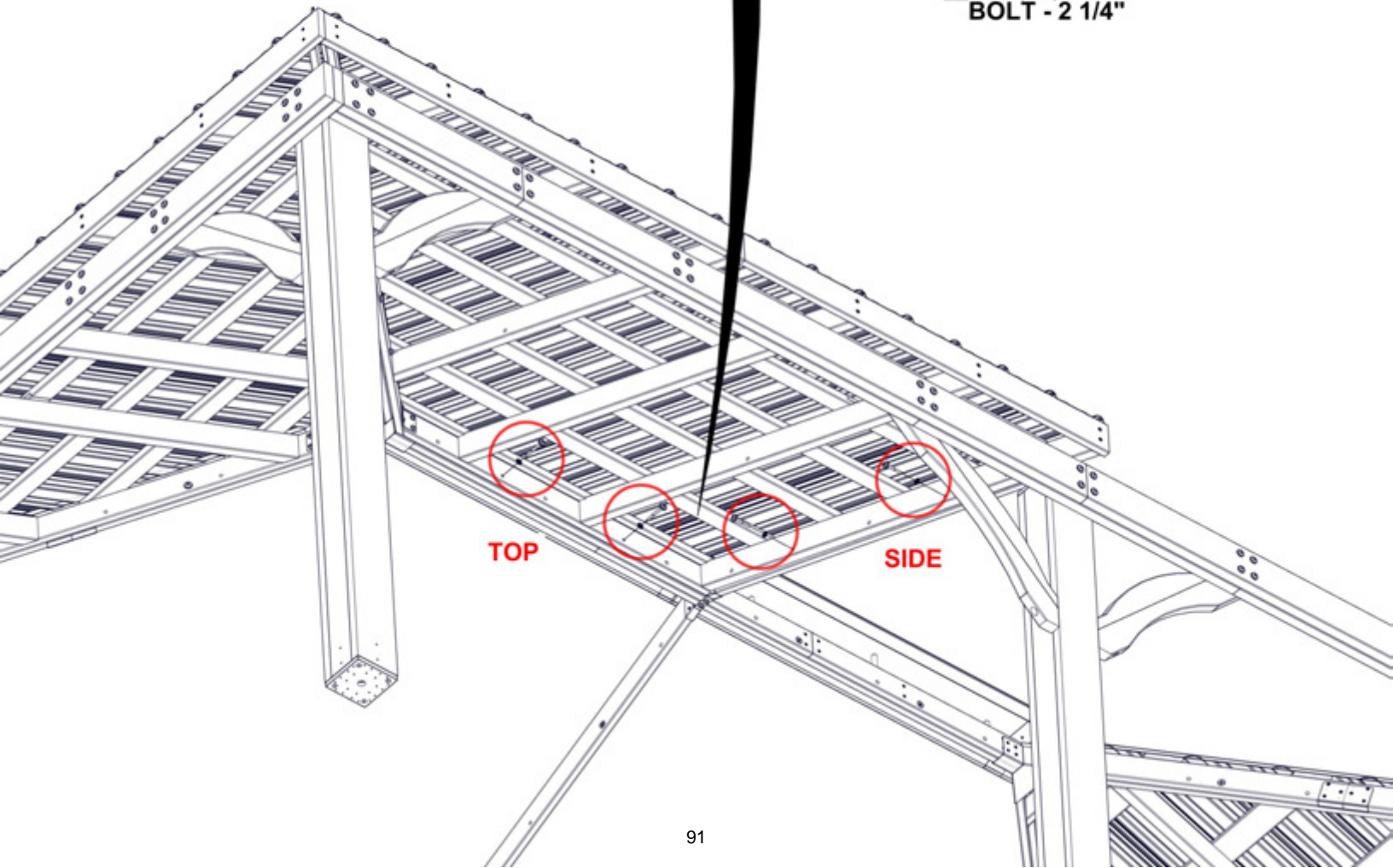

STEP 71 - LEFT ROOF PANEL ATTACHMENT

TIPS:

- THREE PEOPLE ARE HELPFUL FOR THIS STEP.
- POSITION A PERSON ON A LADDER IN THE CENTER OF THE GAZEBO TO HELP SUPPORT THE ROOF PANEL.
- WITH TWO PEOPLE, WORK THE PANEL UP WITHOUT SLIDING OR DRAGGING, UNTIL IT MEETS THE ROOF SUPPORT FRAME.
- MAKE SURE THE ROOF PANEL SLIDES UNDERNEATH THE RIDGE CAP.

WARNING: GLOVES ARE RECOMMENDED WHEN HANDLING STEEL ROOF PIECES

**CRITICAL:
MAKE SURE T-NUTS FROM STEP 18 AND 26 ARE
INSTALLED IN THE ROOF SUPPORT ASSEMBLY
AND H05 RAFTER.**

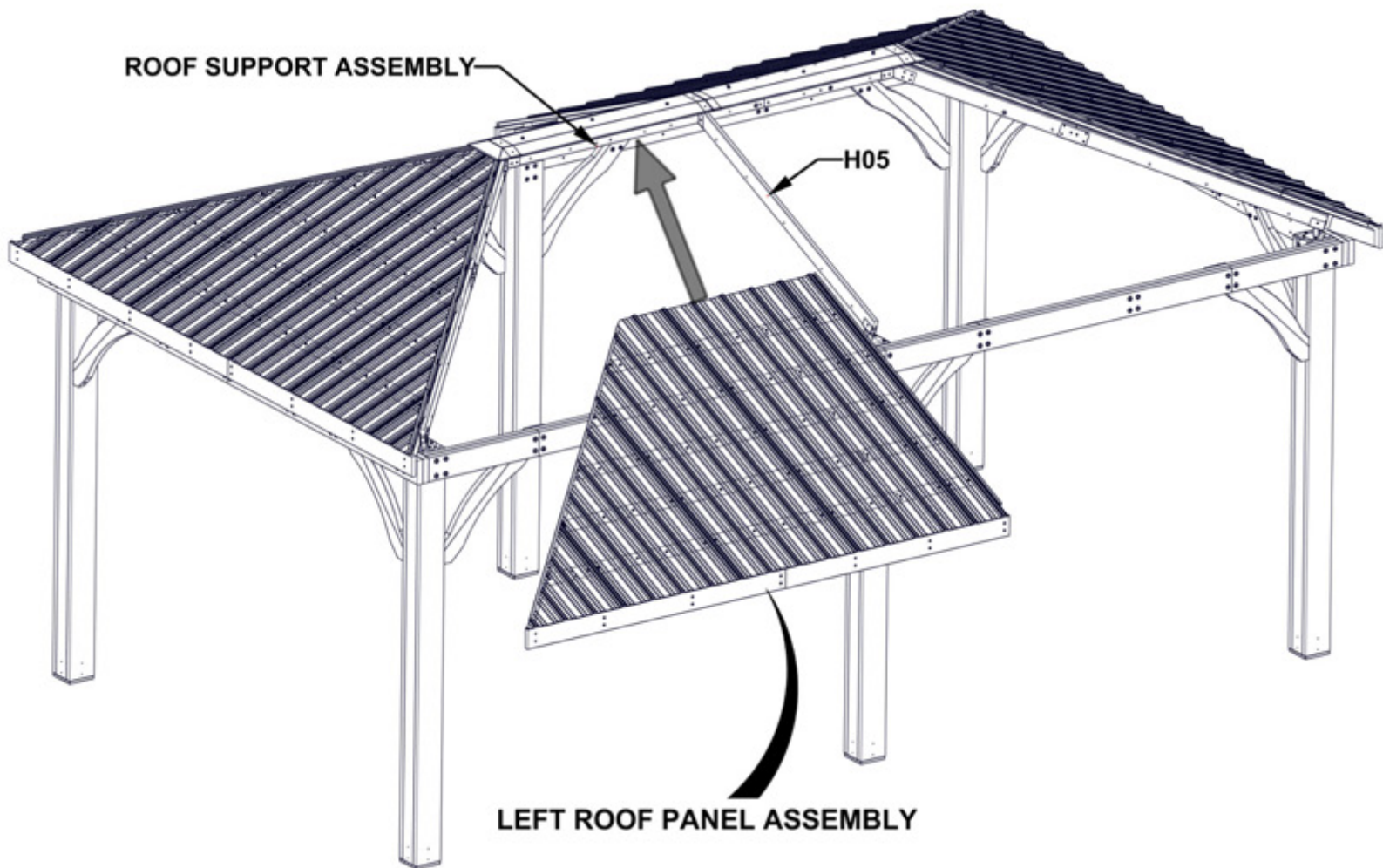

STEP 72 - LEFT ROOF PANEL ATTACHMENT

QTY	PART NUMBER	DESCRIPTION
2	H100205	BOLT WH 5/16x2 1/4 BLK
2	H100195	BOLT WH 5/16x2 3/4 BLK
4	H100198	WASHER LOCK EXT 8x19

TIPS:
 - IF NECESSARY, USE A CLAMP TO HOLD PANELS IN PLACE.

HAND TIGHTEN ONLY

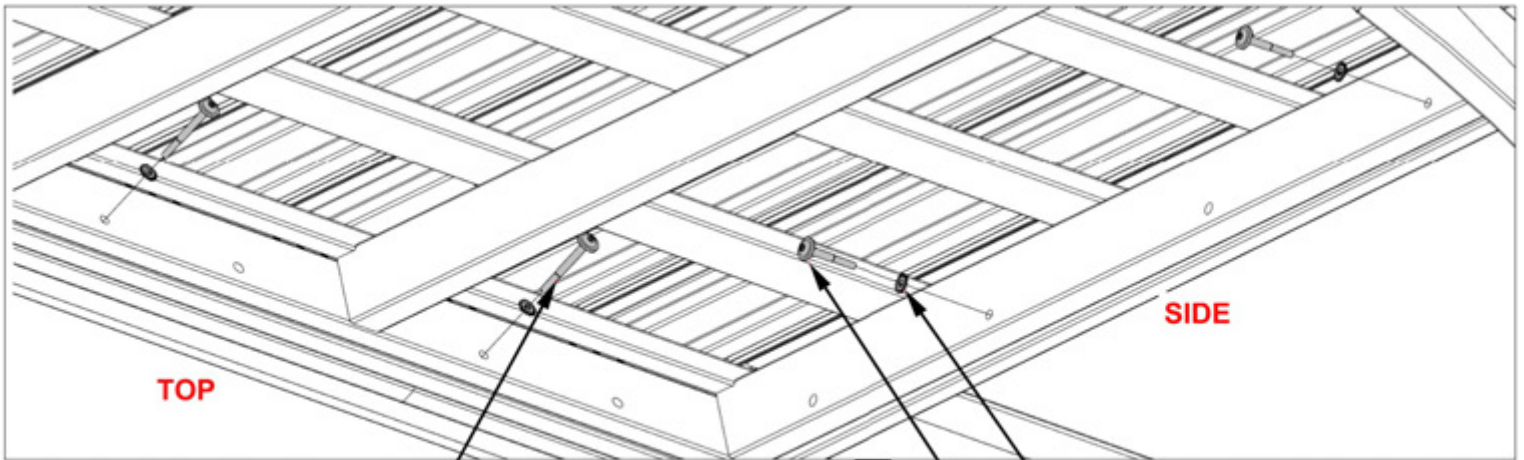

TOP

SIDE

195 (x2)
 BOLT-2 3/4"

198 (x4)
 WASHER - 8x19

205 (x2)
 BOLT - 2 1/4"

NOTE HARDWARE LOCATION AND BOLT CALLOUTS

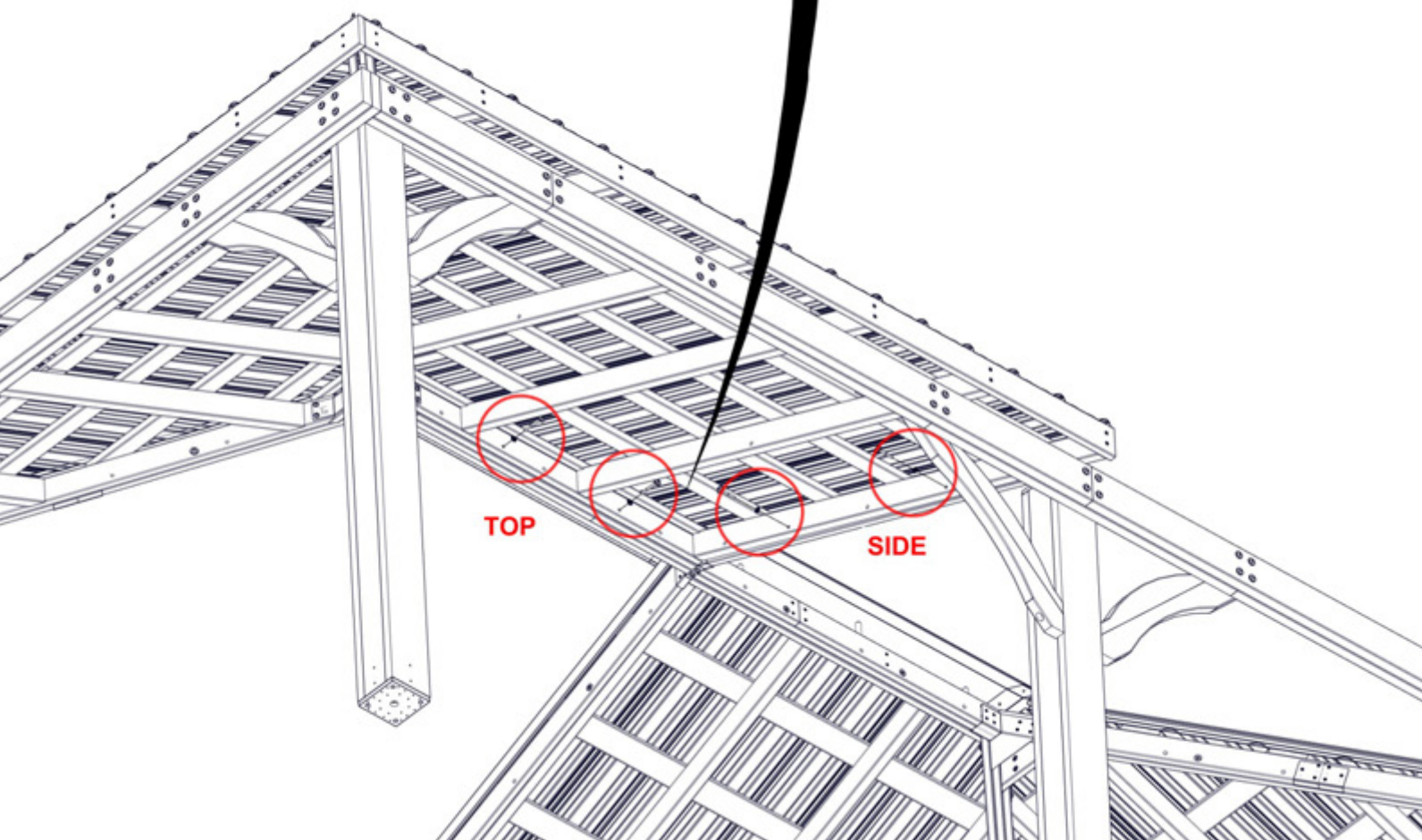

TOP

SIDE

STEP 73 - RIGHT ROOF PANEL ATTACHMENT

TIPS:

- THREE PEOPLE ARE HELPFUL FOR THIS STEP.
- POSITION A PERSON ON A LADDER IN THE CENTER OF THE GAZEBO TO HELP SUPPORT THE ROOF PANEL.
- WITH TWO PEOPLE, WORK THE PANEL UP WITHOUT SLIDING OR DRAGGING, UNTIL IT MEETS THE ROOF SUPPORT FRAME.
- MAKE SURE THE ROOF PANEL SLIDES UNDERNEATH THE RIDGE CAP.

WARNING: GLOVES ARE RECOMMENDED WHEN HANDLING STEEL ROOF PIECES

**CRITICAL:
MAKE SURE T-NUTS FROM STEP 18 AND 26 ARE
INSTALLED IN THE ROOF SUPPORT.**

ROOF SUPPORT ASSEMBLY

RIGHT ROOF PANEL
ASSEMBLY

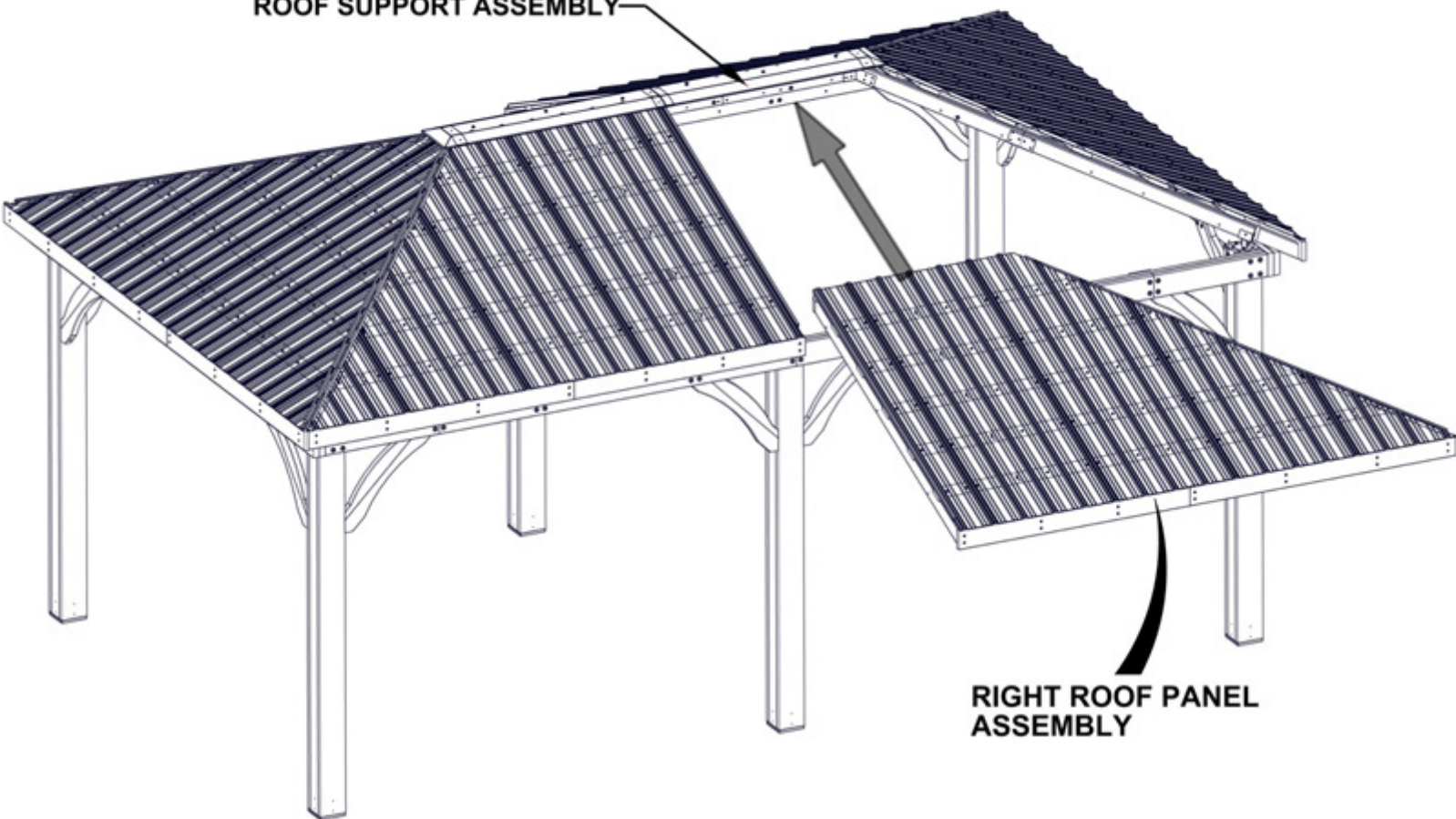

STEP 74 - RIGHT ROOF PANEL ATTACHMENT

QTY	PART NUMBER	DESCRIPTION
3	H100480	BOLT WH 5/16x4 3/4 BLK
3	H100198	WASHER LOCK EXT 8x19
3	H100770	WASHER FLAT 5/16 BLK
3	H100479	NUT LOCK 5/16 BLK

TIPS:
- IF NECESSARY, USE A CLAMP TO HOLD PANELS IN PLACE.

HAND TIGHTEN ONLY

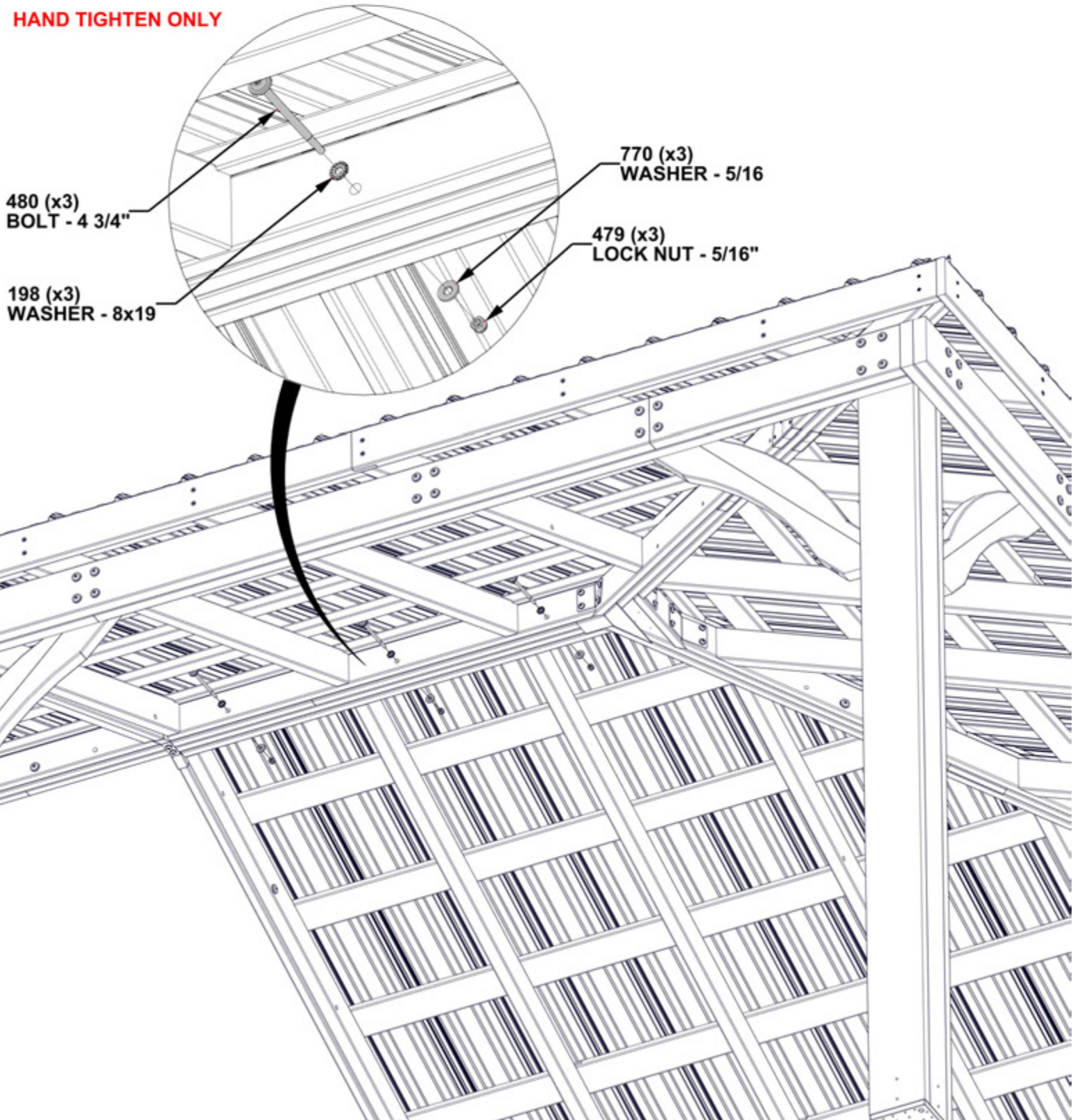

STEP 75 - RIGHT ROOF PANEL ATTACHMENT

TIPS:

- THREE PEOPLE ARE HELPFUL FOR THIS STEP.
- POSITION A PERSON ON A LADDER IN THE CENTER OF THE GAZEBO TO HELP SUPPORT THE ROOF PANEL.
- WITH TWO PEOPLE, WORK THE PANEL UP WITHOUT SLIDING OR DRAGGING, UNTIL IT MEETS THE ROOF SUPPORT FRAME.
- MAKE SURE THE ROOF PANEL SLIDES UNDERNEATH THE RIDGE CAP.

WARNING: GLOVES ARE RECOMMENDED WHEN HANDLING STEEL ROOF PIECES

**CRITICAL:
MAKE SURE T-NUTS FROM STEP 18 AND 26 ARE
INSTALLED IN THE ROOF SUPPORT.**

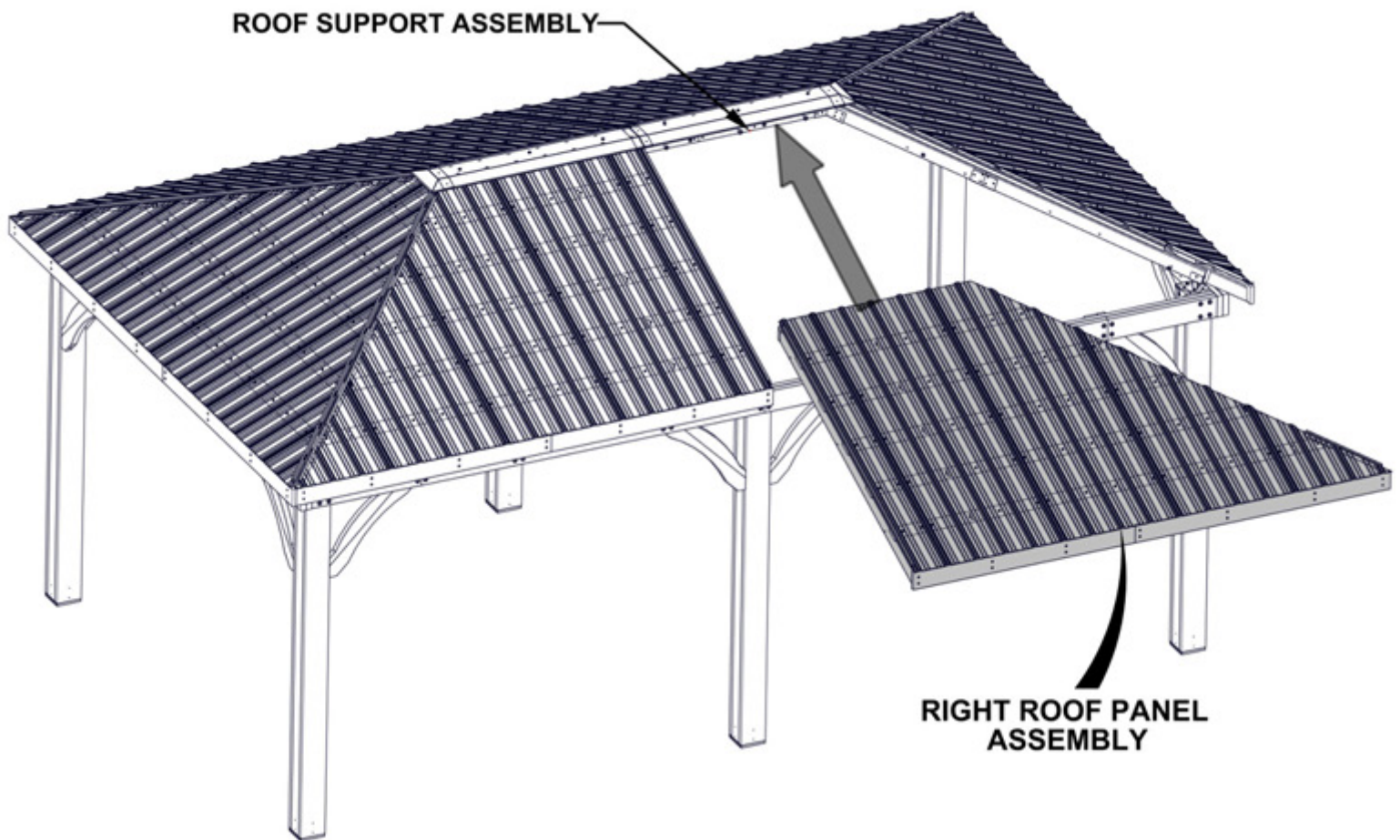

STEP 76 - RIGHT ROOF PANEL ATTACHMENT

QTY	PART NUMBER	DESCRIPTION
3	H100480	BOLT WH 5/16x4 3/4 BLK
3	H100198	WASHER LOCK EXT 8x19
3	H100479	NUT LOCK 5/16 BLK
3	H100770	WASHER FLAT 5/16 BLK

TIPS:
- IF NECESSARY, USE A CLAMP TO HOLD PANELS IN PLACE.

HAND TIGHTEN ONLY

480 (x3)
BOLT - 4 3/4"

198 (x3)
WASHER - 8x19

770 (x3)
WASHER - 5/16

479 (x3)
LOCK NUT - 5/16"

STEP 77 -ROOF PANEL ATTACHMENT

QTY	PART NUMBER	DESCRIPTION
20	H100415	BOLT WH 5/16x3 3/4 BLK
20	H100479	NUT LOCK 5/16 BLK
20	H100770	WASHER FLAT 5/16 BLK
20	H100198	WASHER LOCK EXT 8x19

REPEAT ON ALL FOUR DIAGONAL ROOF JOIST

HAND TIGHTEN ONLY

IF THE HOLES ARE SLIGHTLY OFFSET, USE A SCREWDRIVER TO HELP ALIGN, OR DRILL WITH A 3/8" (10mm) DRILL BIT. THIS WILL ENABLE THE BOLTS TO BE INSERTED.

415 (x5)
BOLT - 3 3/4"

198 (x5)
WASHER - 8x19"

770 (x5)
WASHER - 5/16"

479 (x5)
LOCK NUT - 5/16"

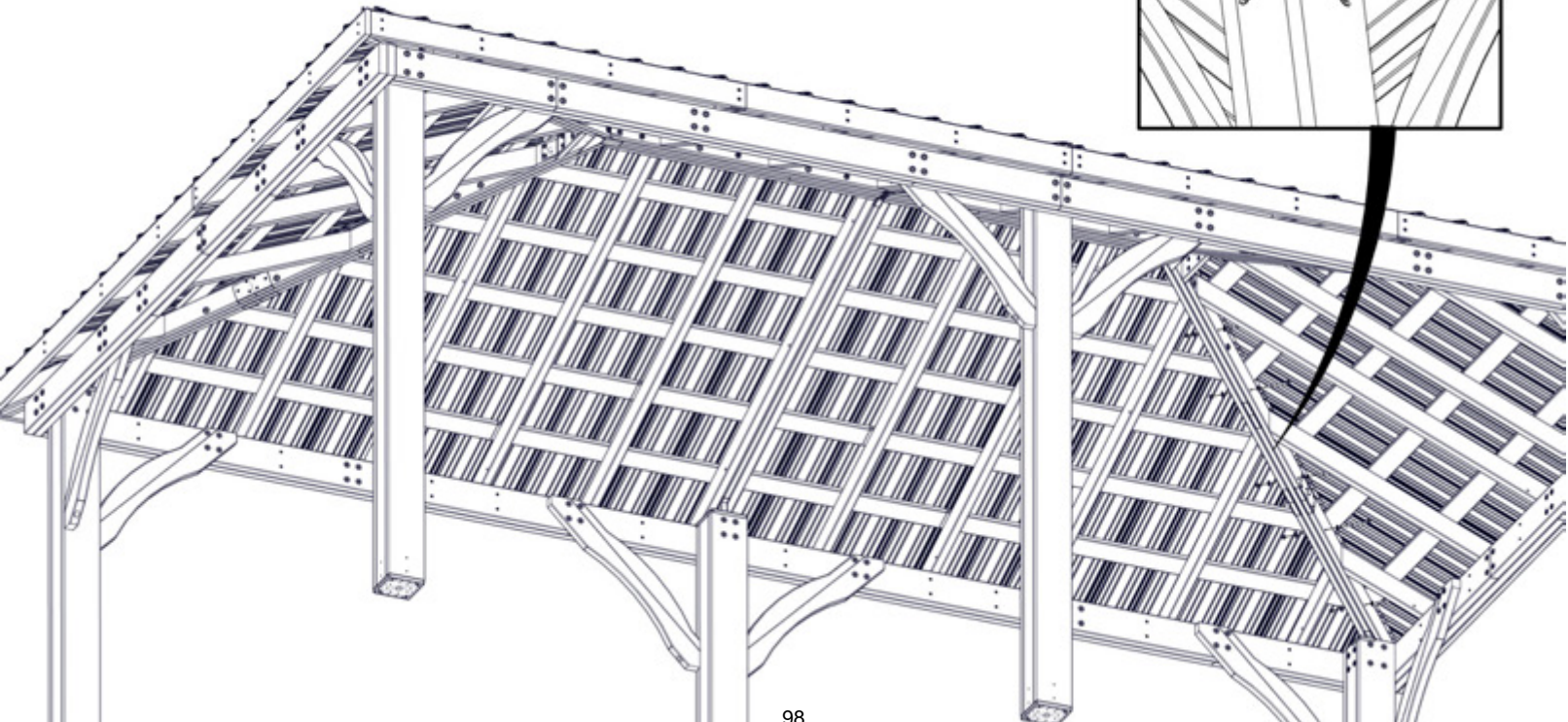
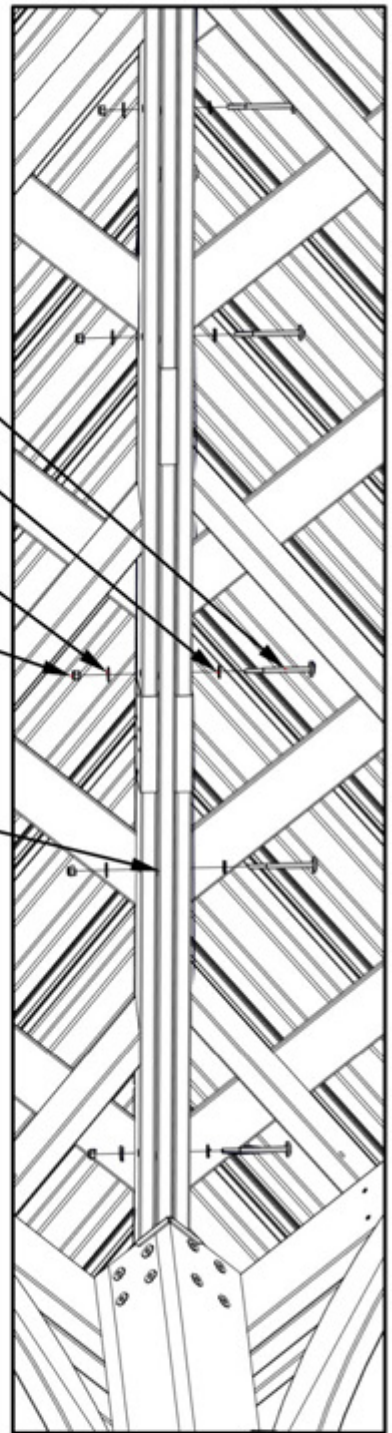

STEP 78 - ROOF PANEL ATTACHMENT

QTY	PART NUMBER	DESCRIPTION
6	H100534	BOLT WH 5/16x4 1/2 BLK
6	H100198	WASHER LOCK EXT 8x19
6	H100770	WASHER FLAT 5/16 BLK
6	H100479	NUT LOCK 5/16 BLK

ATTACH PANEL HARDWARE TO CONNECT LEFT AND RIGHT PANEL TO MIDDLE RAFTER.

HAND TIGHTEN ONLY

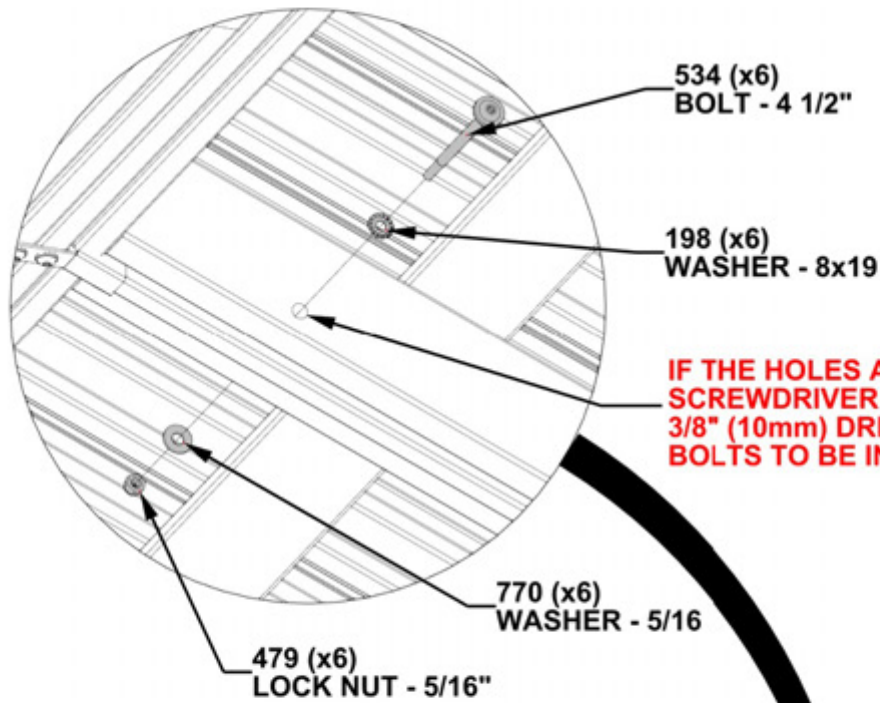

IF THE HOLES ARE SLIGHTLY OFFSET, USE A SCREWDRIVER TO HELP ALIGN, OR DRILL WITH A 3/8" (10mm) DRILL BIT. THIS WILL ENABLE THE BOLTS TO BE INSERTED.

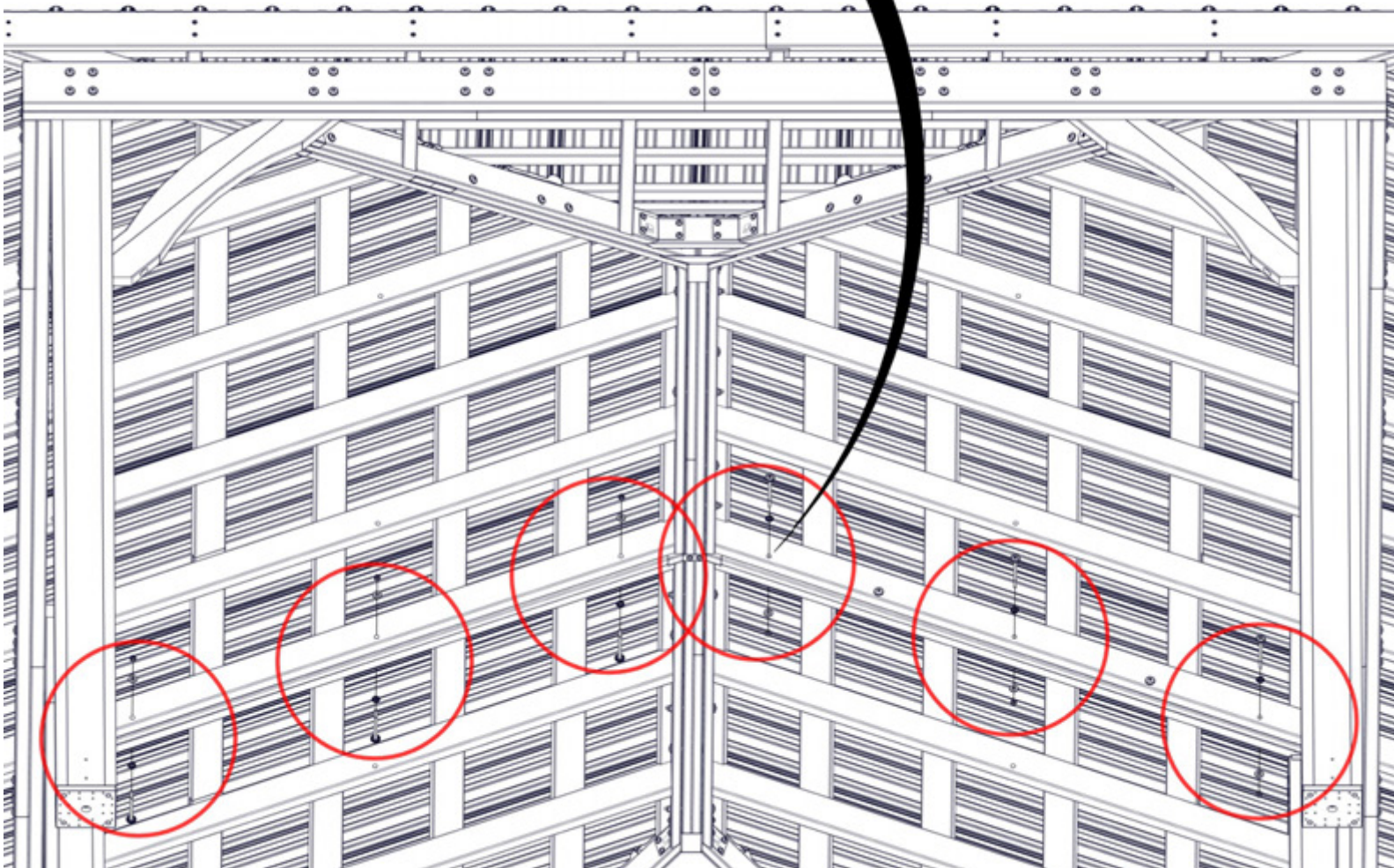

STEP 79 - ROOF PANEL ATTACHMENT

QTY	PART NUMBER	DESCRIPTION
4	H100479	NUT LOCK 5/16 BLK
4	H100770	WASHER FLAT 5/16 BLK
4	H100503	BOLT WH 5/16x3 1/2 BLK
4	H100478	WASHER FLAT 8x27 BLK



E17 COLLAR TIE - W4L17573
(x2) 1 3/8"x3 3/8"x71 5/8" (36x86x1820)

ATTACH COLLAR TIES ONE RAFTER FROM THE CENTER ON EITHER SIDE.

HAND TIGHTEN ONLY

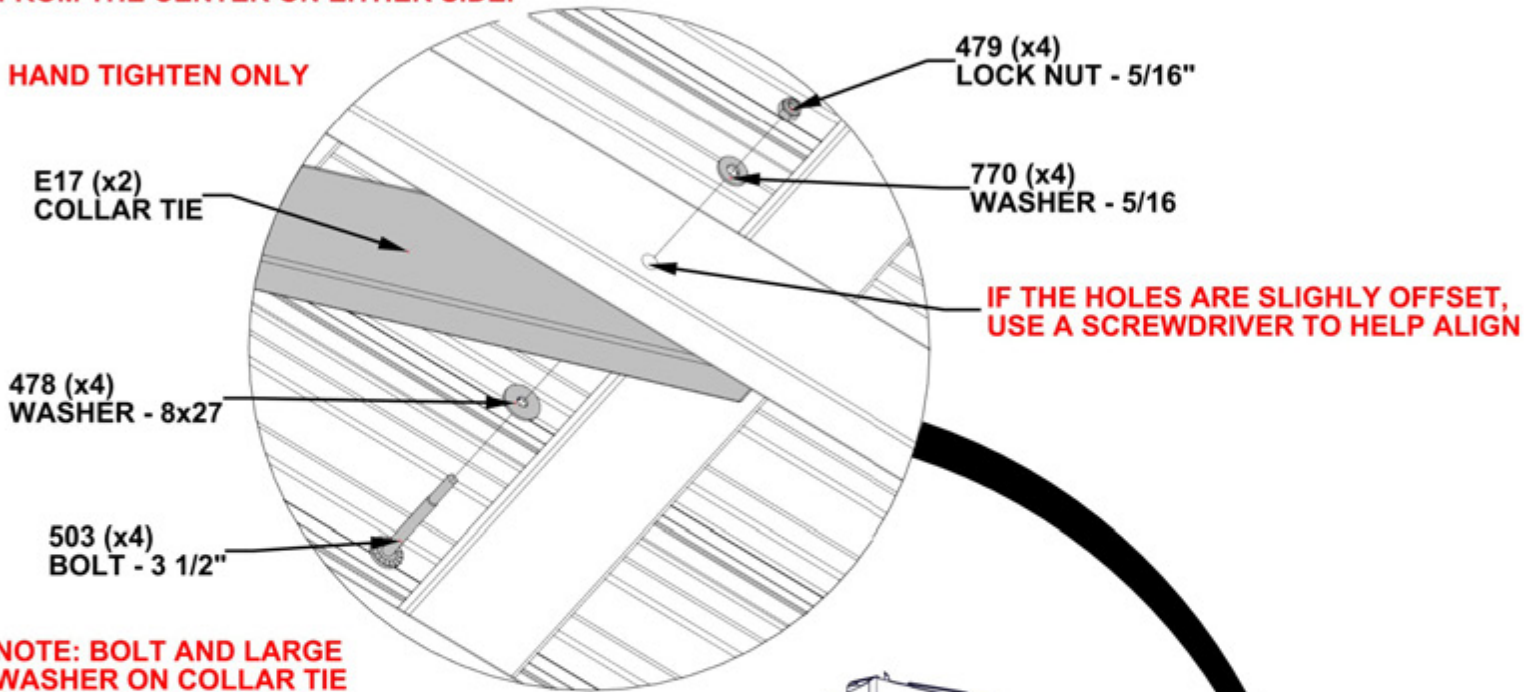

NOTE: BOLT AND LARGE WASHER ON COLLAR TIE SIDE

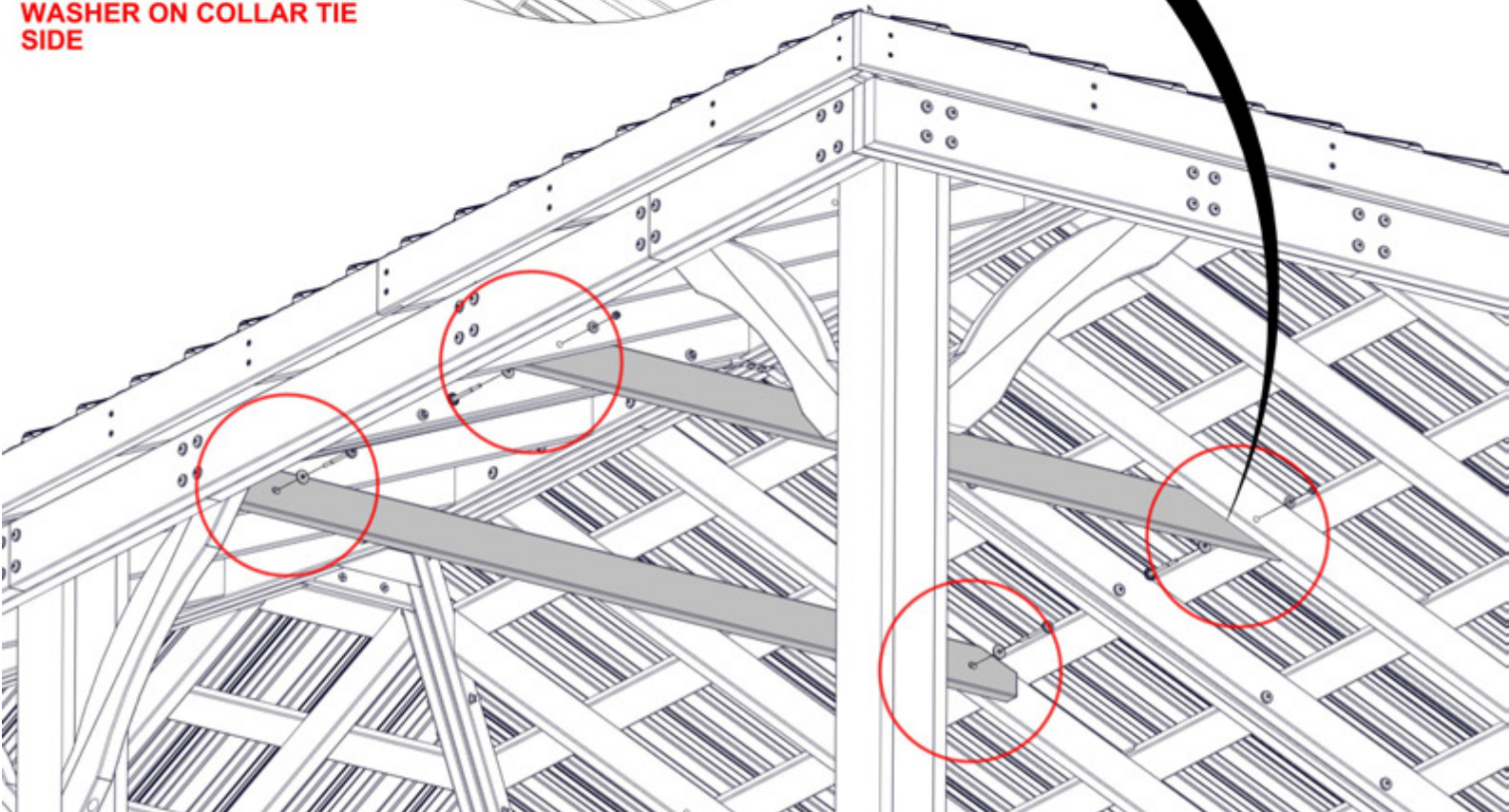

STEP 80 - ROOF PANEL ATTACHMENT

QTY	PART NUMBER	DESCRIPTION
4	H100503	BOLT WH 5/16x3 1/2 BLK
4	H100478	WASHER FLAT 8x27 BLK
4	H100770	WASHER FLAT 5/16 BLK
4	H100479	NUT LOCK 5/16 BLK



E17 COLLAR TIE - W4L17573
(x2) 1 3/8"x3 3/8"x71 5/8" (36x86x1820)

HAND TIGHTEN ONLY

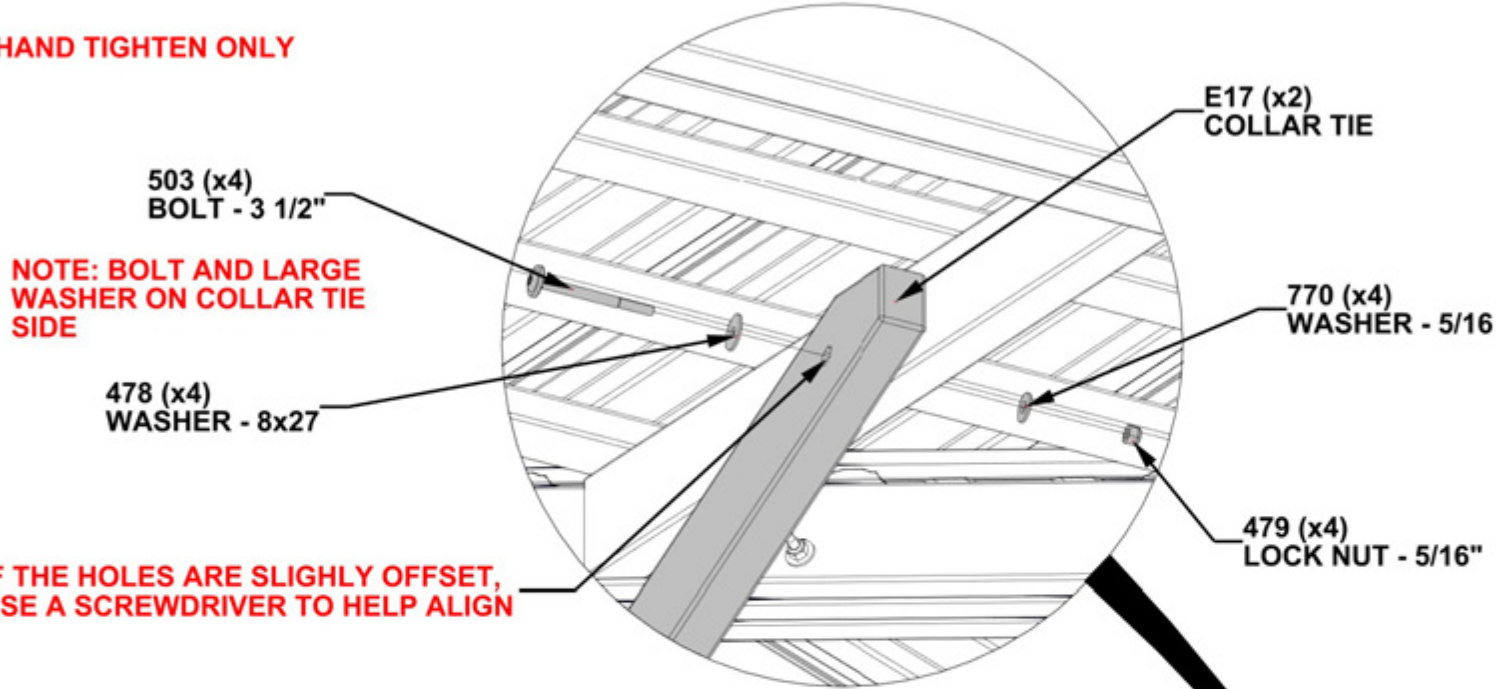

IF THE HOLES ARE SLIGHTLY OFFSET, USE A SCREWDRIVER TO HELP ALIGN

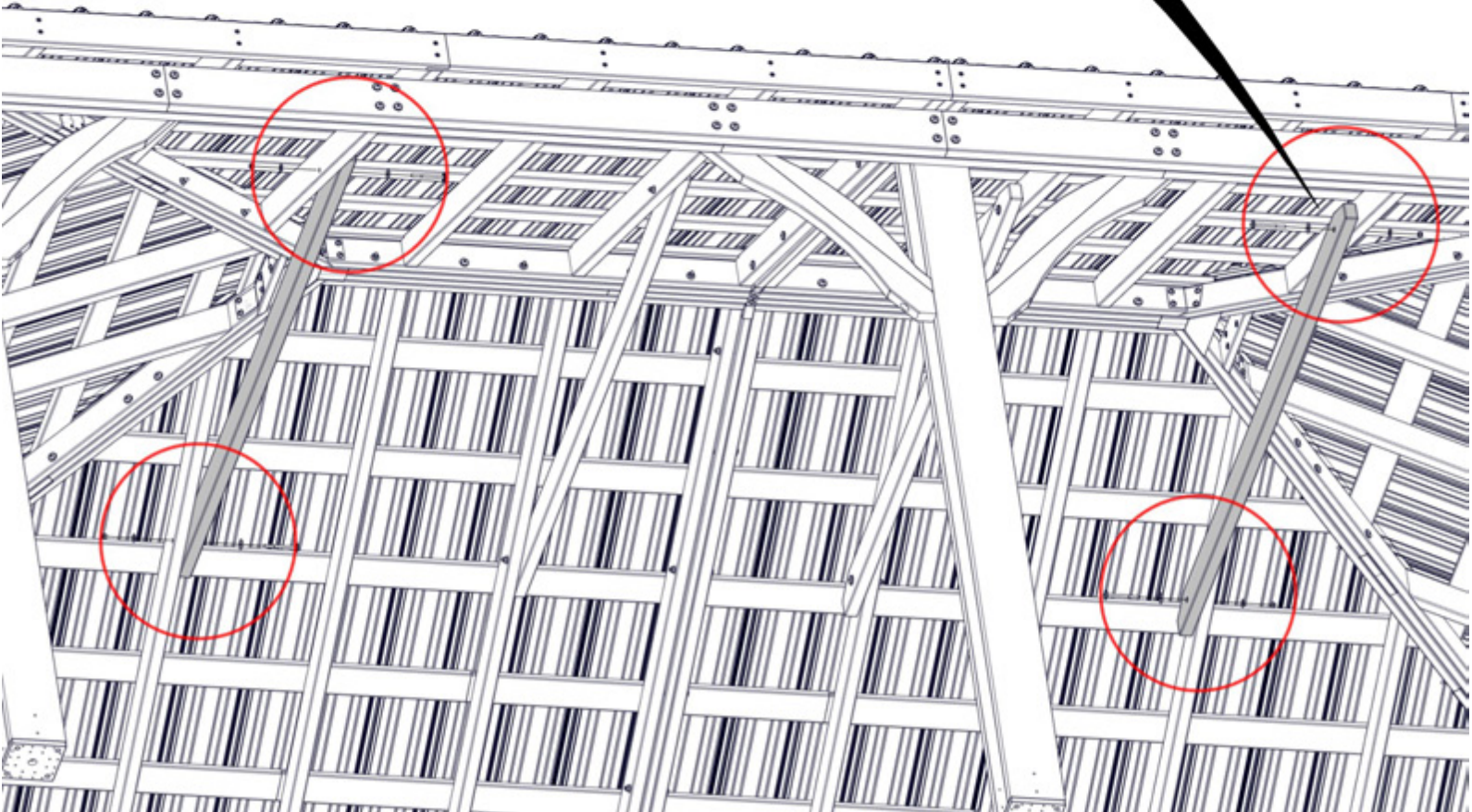

STEP 81 - ROOF PANEL ATTACHMENT

**TIGHTEN ALL THE HARDWARE IN THE ORDER SHOWN BELOW.
START AT THE TOP AND WORK YOUR WAY DOWN.**

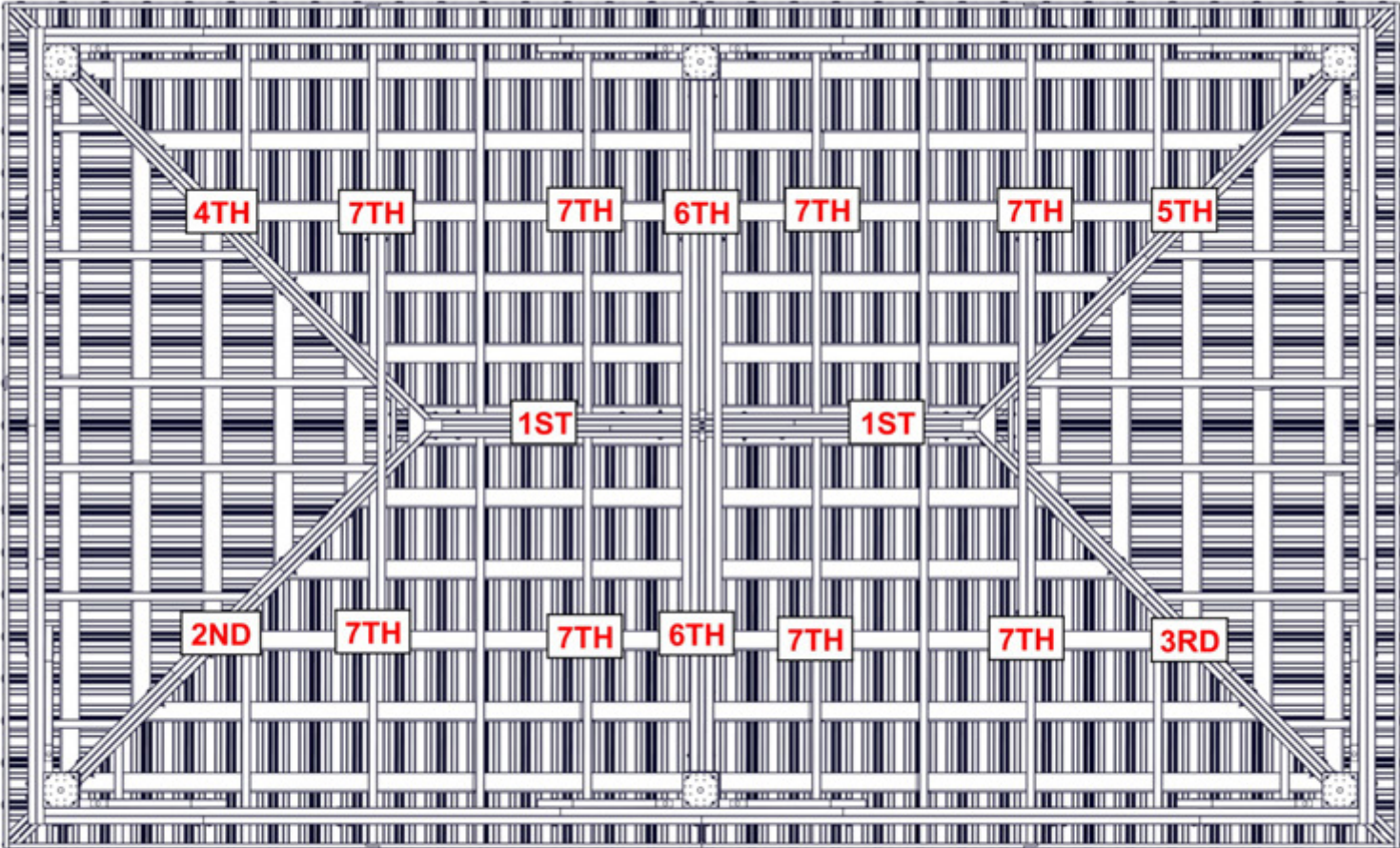

STEP 82 - ROOF ASSEMBLY

QTY	PART NUMBER	DESCRIPTION
20	H100653	NUT LOCK 1/4 BLK
20	H100488	BOLT WH 1/4x2 BLK
20	H100630	WASHER FLAT 8x19 BLK
40	H100536	SCREW PWH 8x1 1/4 BLK



RAFTER CLIP - A4M01228
(x20) 1/16"x4 1/8"x4 7/16" (1.5x104x4 7/16")

**INSERT BOLTS FIRST,
THEN SCREW IN BRACKET**

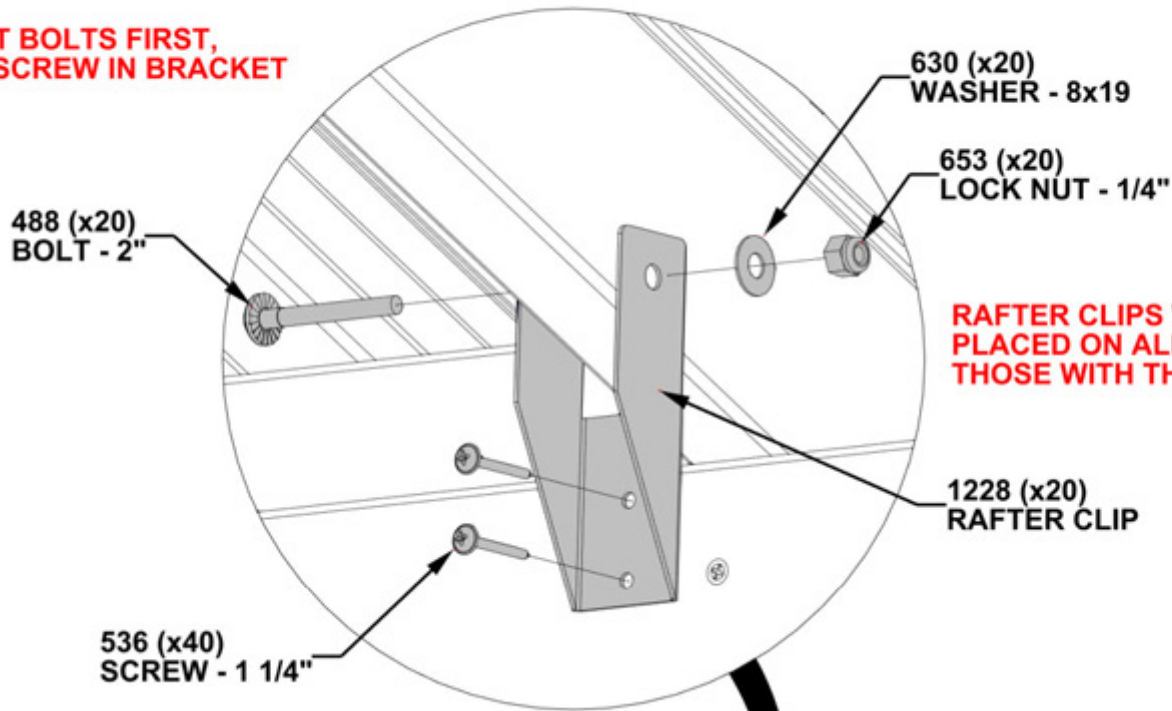

**RAFTER CLIPS WILL NOT BE
PLACED ON ALL RAFTERS, ONLY
THOSE WITH THROUGH HOLES.**

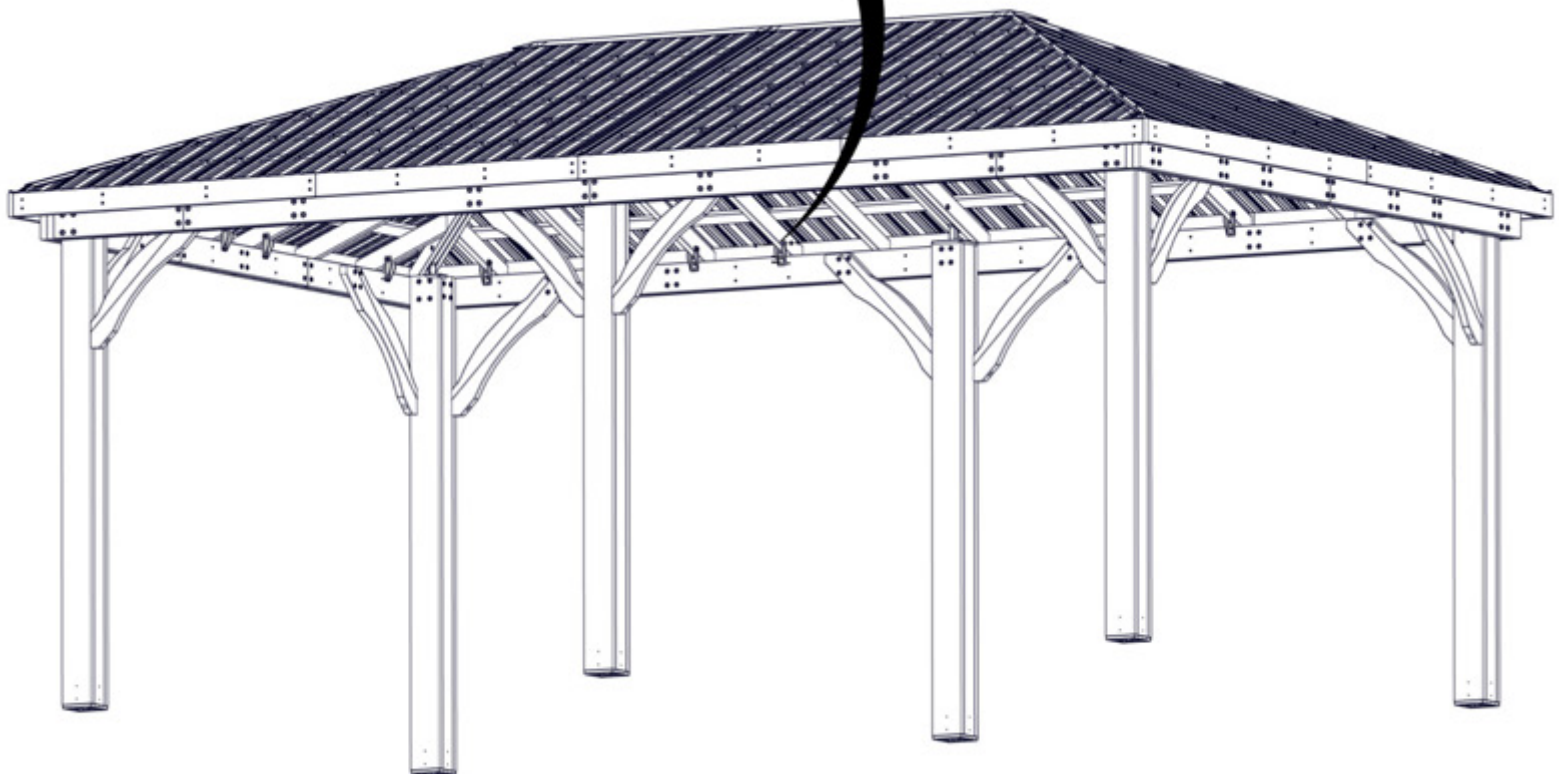

STEP 83 - ROOF ASSEMBLY

QTY	PART NUMBER	DESCRIPTION
16	H100392	SCREW PWH 8x3/4 BLK



A4M01185 CORNER BRACKET
(x4)

REPEAT ON ALL FOUR CORNERS

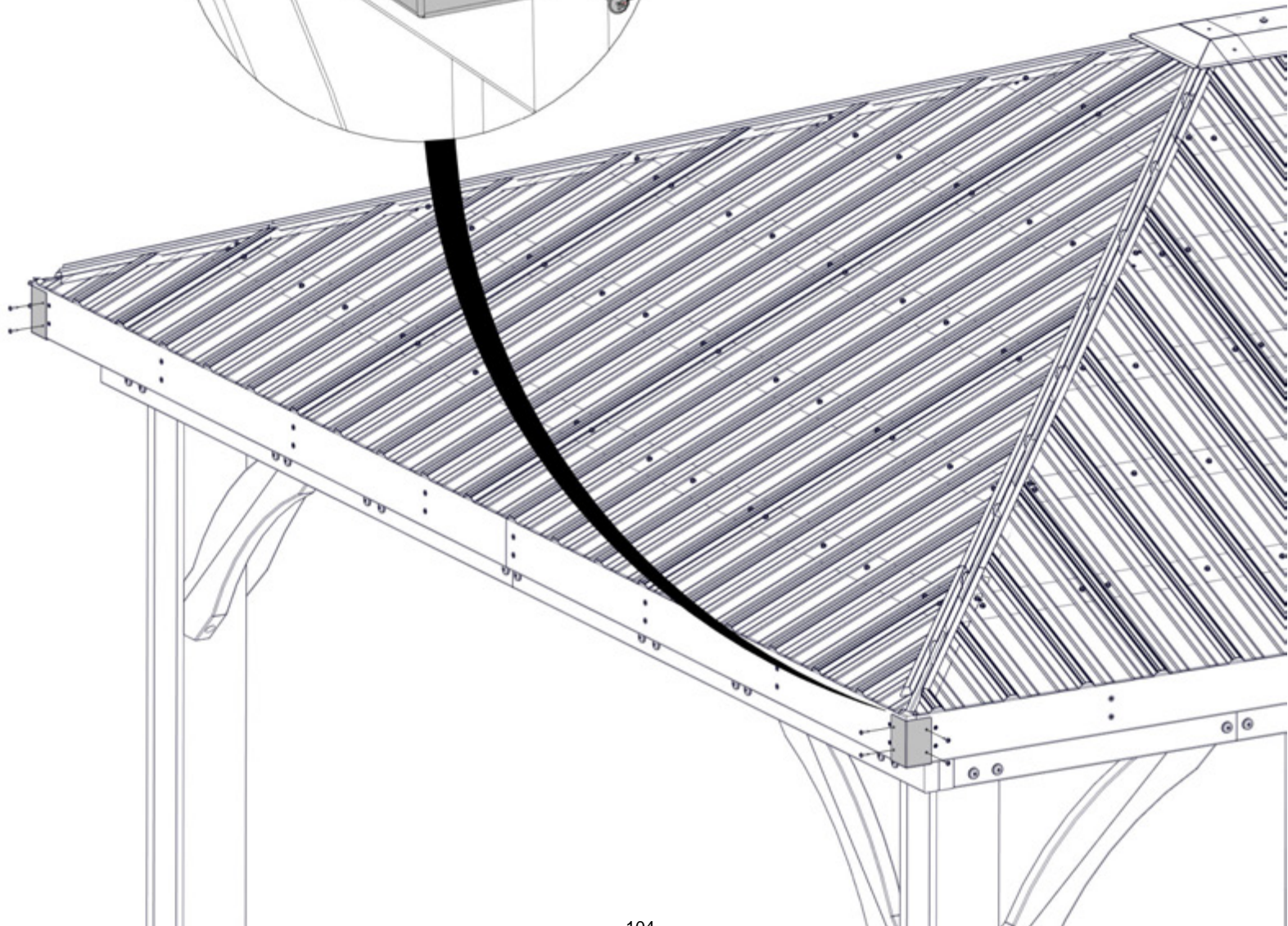
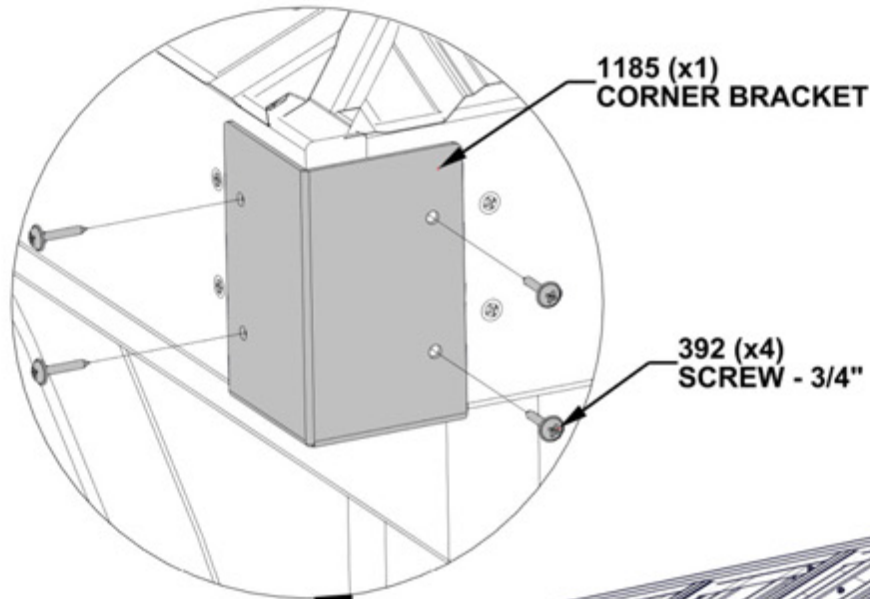

STEP 84 - ROOF ASSEMBLY

QTY	PART NUMBER	DESCRIPTION
8	H100392	SCREW PWH 8x3/4 BLK

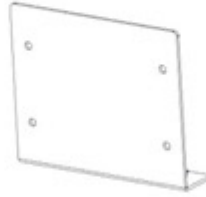

A4M01904 SPLICE PLATE
(x2)

REPEAT ON BOTH 20FT SIDES

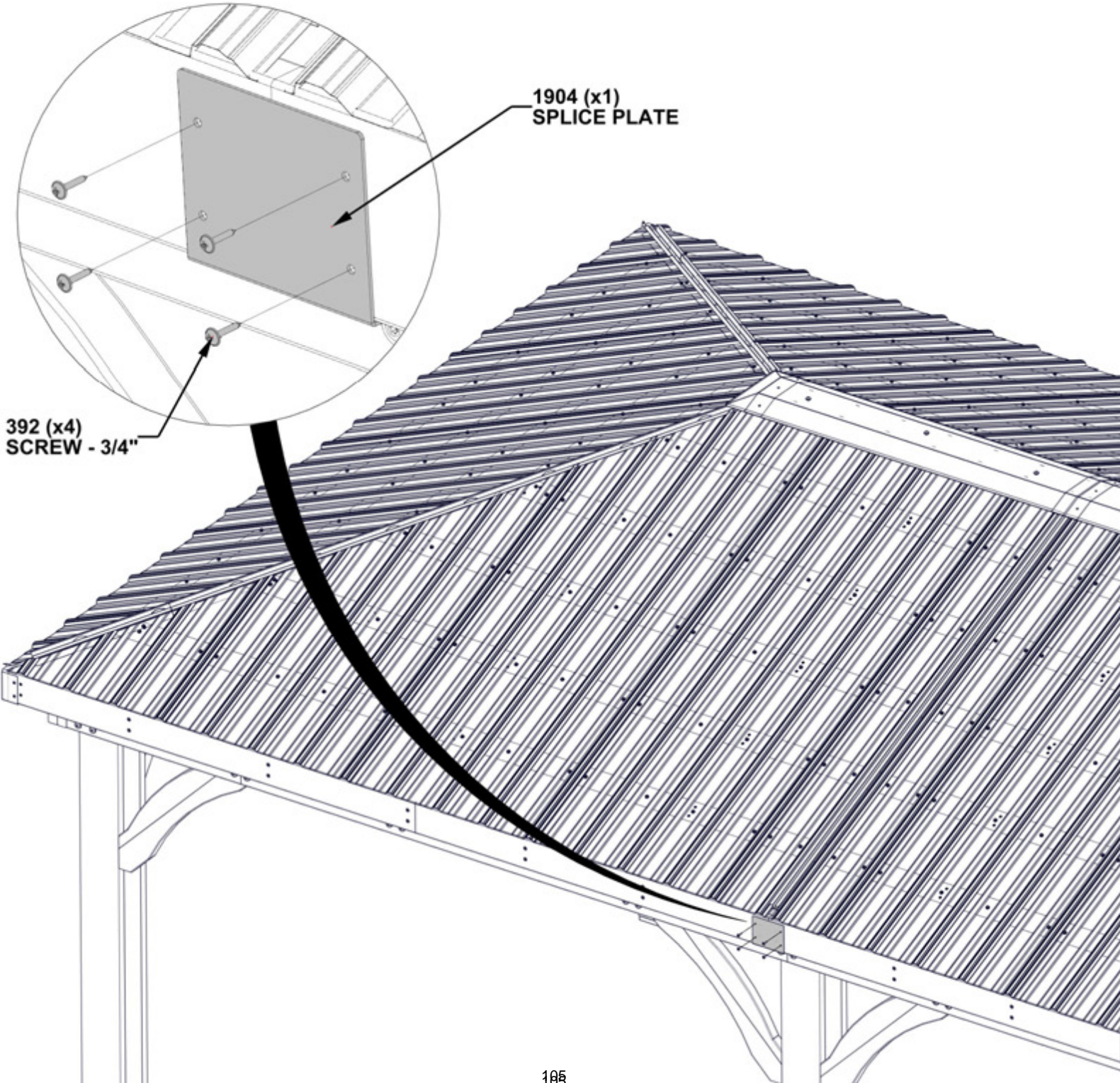

STEP 85 - ROOF TRIM

QTY	PART NUMBER	DESCRIPTION
32	H100759	SCREW SELF TAPPING 1/4x1



A4M02820 EDGE TRIM
(x6)



A4M02825 EDGE TRIM
CORNER SPLICE
(x4)



A4M02822 EDGE TRIM
SPLICE
(x4)

- TIPS:
- START ON THE LEFT SIDE OF A 20FT PANEL.
 - SLIDE EDGE TRIM PIECES TOGETHER AS SHOWN BELOW.
 - MAKE SURE ALL PANELS ARE COVERED BEFORE INSTALLING SCREWS.
 - INSTALL H100759 SCREWS AS SHOWN.

REPEAT ON OPPOSITE SIDE

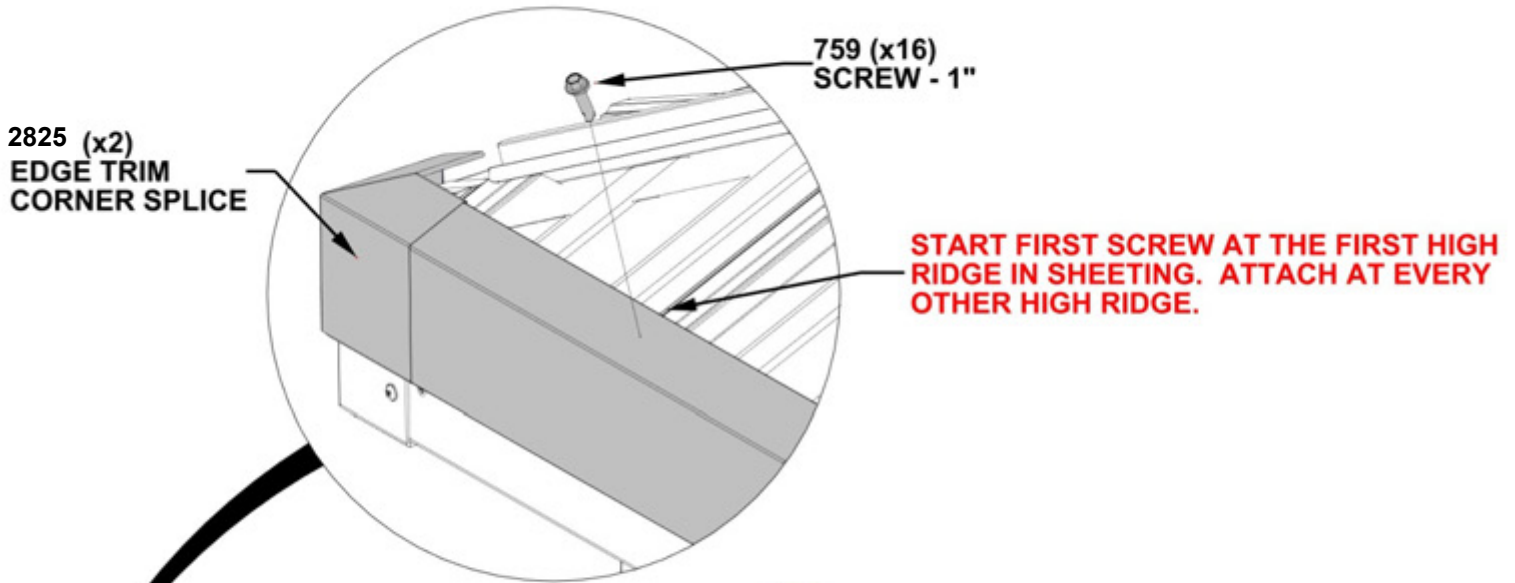

START FIRST SCREW AT THE FIRST HIGH RIDGE IN SHEETING. ATTACH AT EVERY OTHER HIGH RIDGE.

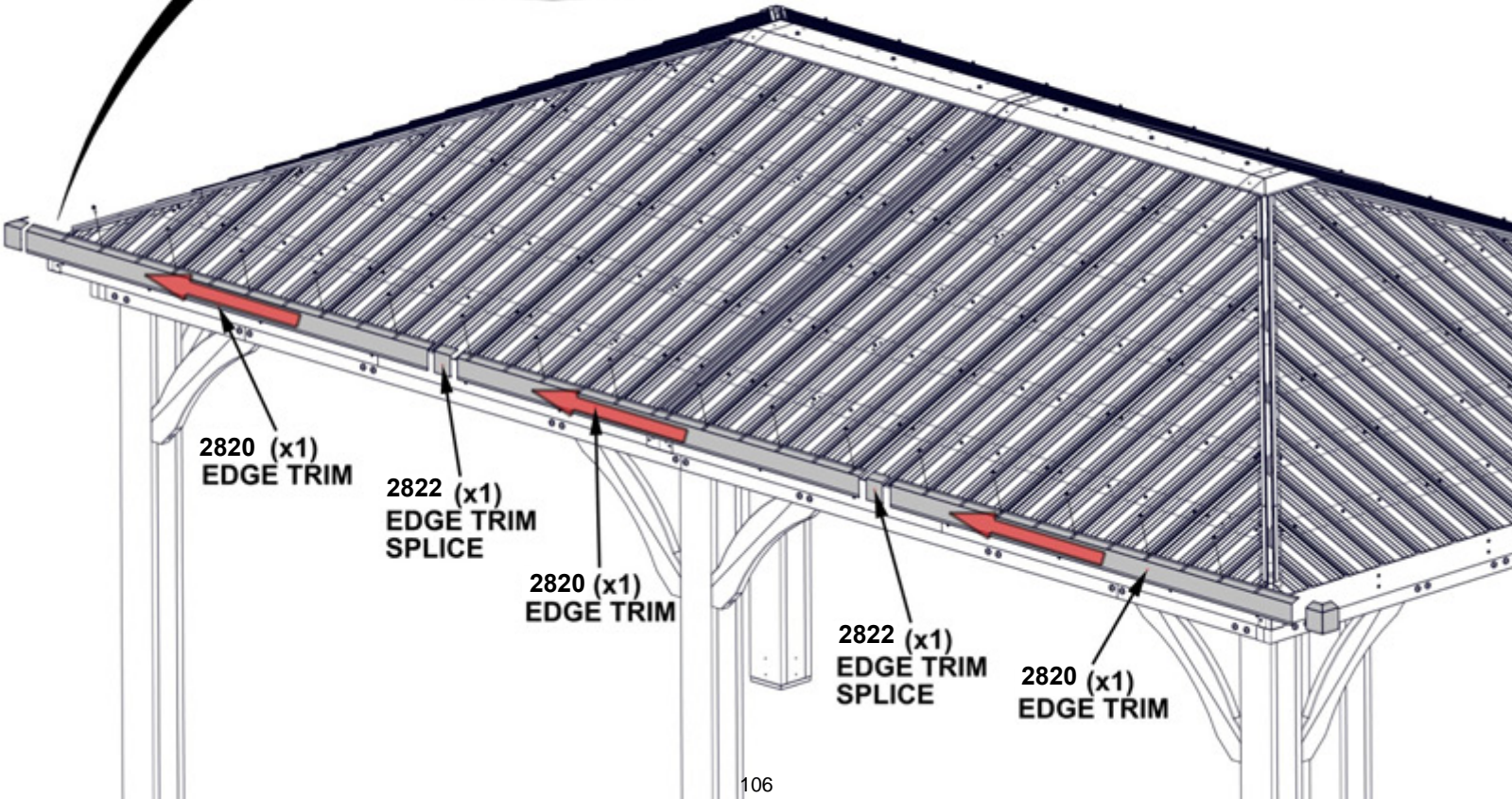

STEP 86 - ROOF TRIM

QTY	PART NUMBER	DESCRIPTION
20	H100759	SCREW SELF TAPPING 1/4x1



A4M02821 EDGE TRIM
(x4)



A4M02822 EDGE TRIM SPLICE
(x2)

- TIPS:
- BEGIN ON THE LEFT OF THE 12FT SIDE
 - SLIDE EDGE TRIM PIECES TOGETHER AS SHOWN BELOW.
 - MAKE SURE ALL PANELS ARE COVERED BEFORE INSTALLING SCREWS.
 - INSTALL H100759 SCREWS AS SHOWN.

REPEAT ON OPPOSITE SIDE

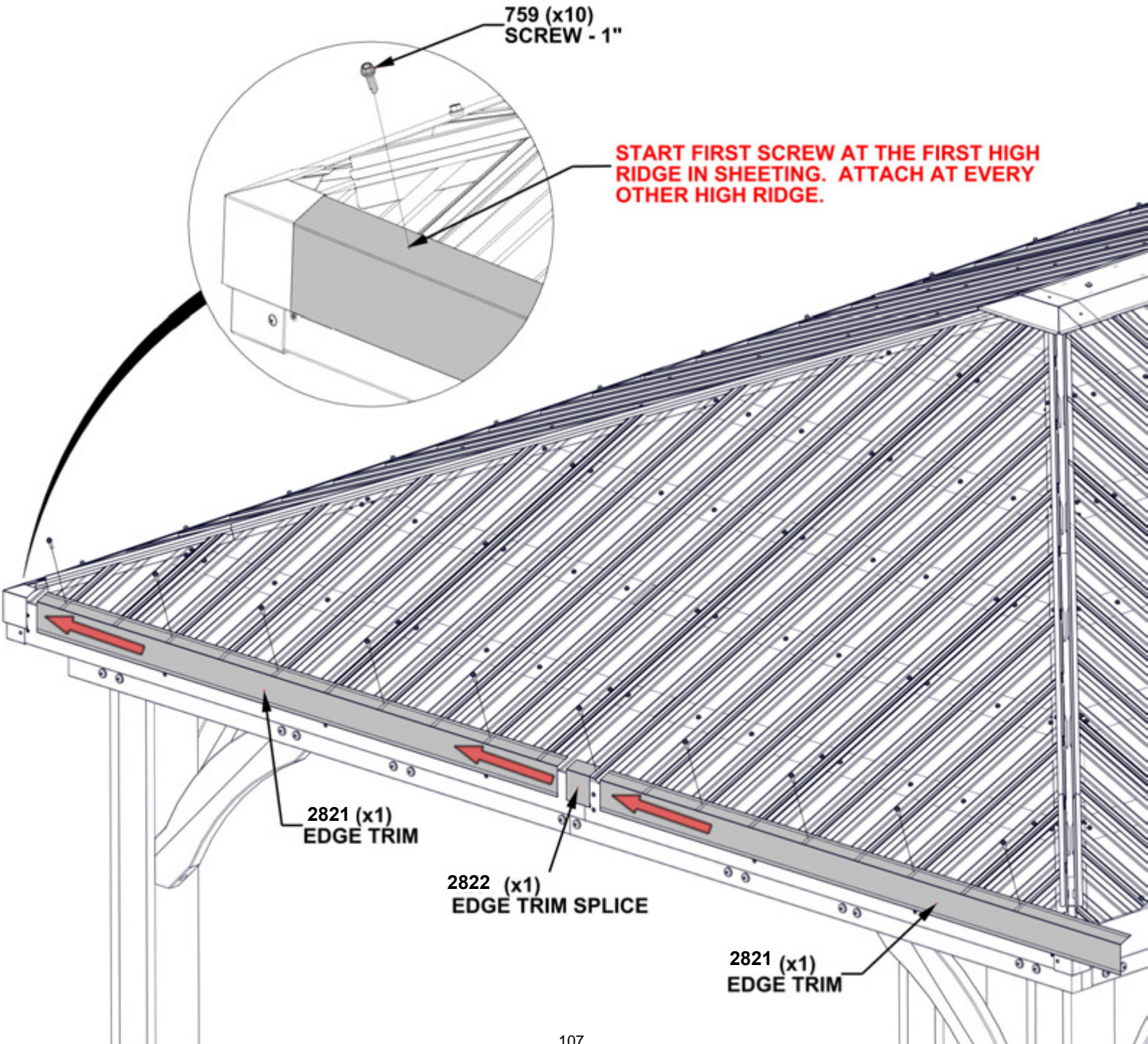

STEP 87 - ROOF TRIM



TIPS:
- SLIDE CORNER RIDGE CAP ONTO ROOF RIDGE CAP CHANNEL AS SHOWN.

REPEAT ON ALL FOUR CORNERS

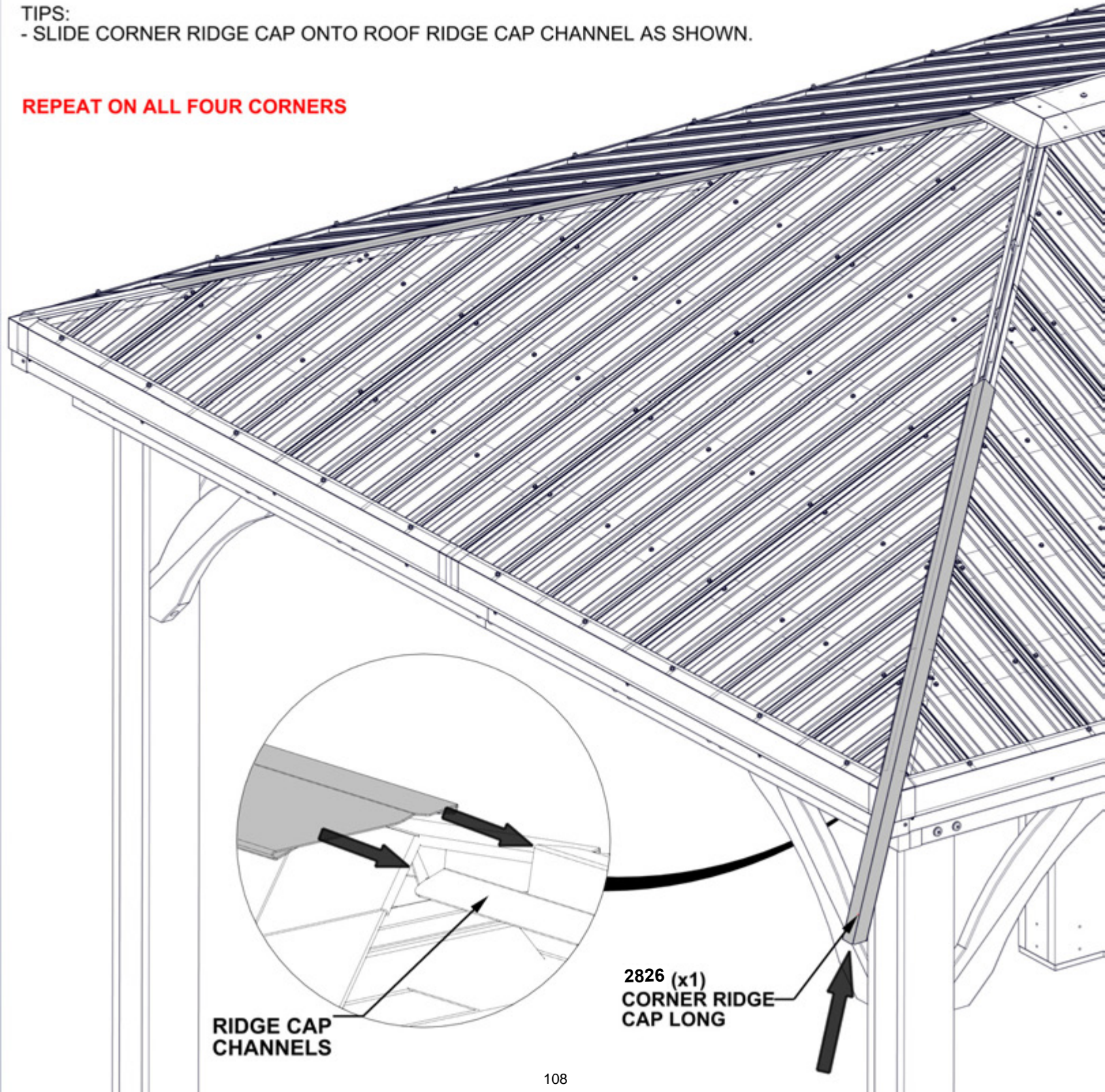

STEP 88 - ROOF TRIM



A4M02867 RIDGE CAP SPLICE ASSEMBLY
(x4)

REPEAT ON ALL FOUR CORNERS

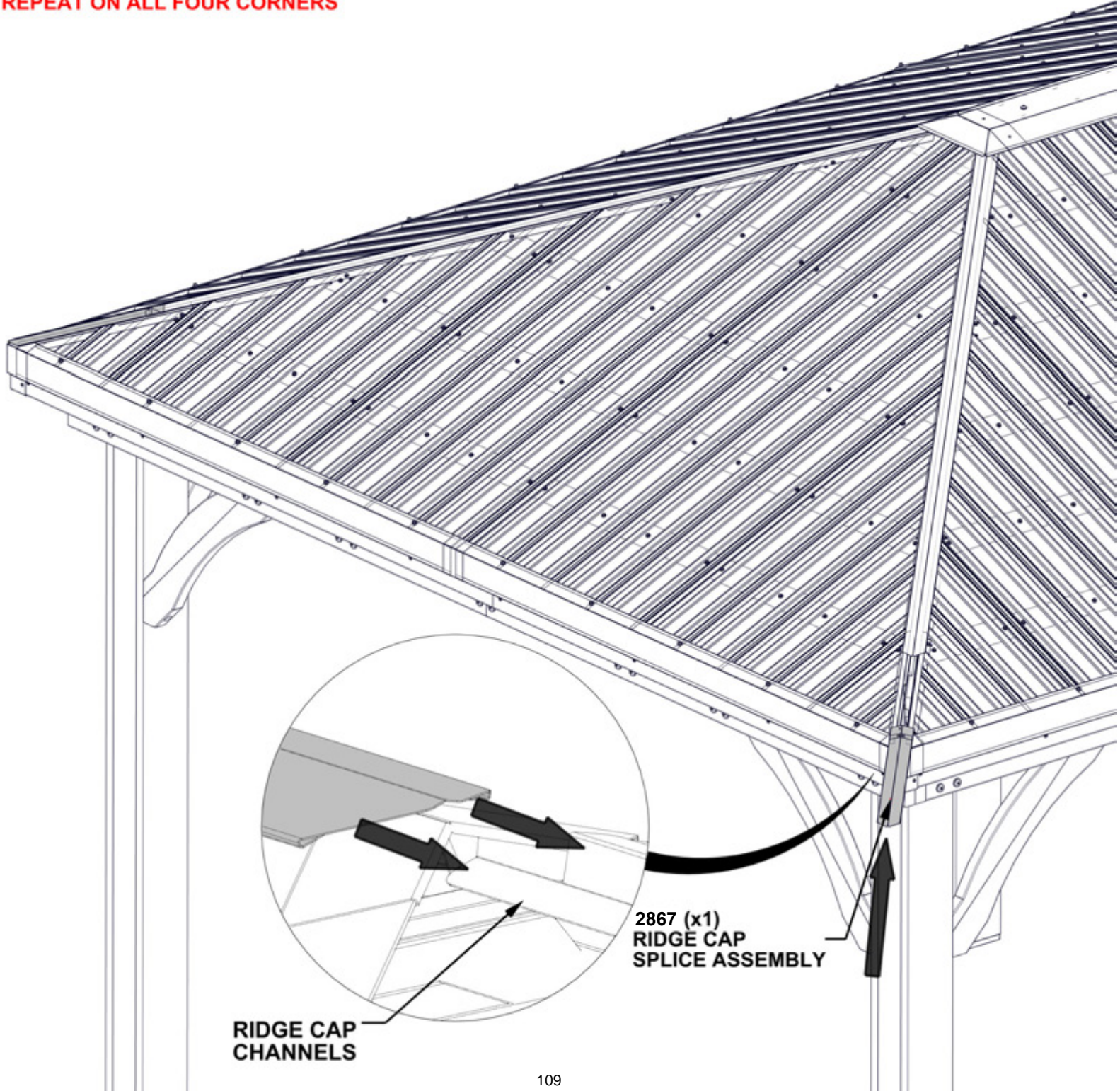

RIDGE CAP CHANNELS

2867 (x1)
RIDGE CAP
SPLICE ASSEMBLY

STEP 89 - ROOF TRIM

QTY	PART NUMBER	DESCRIPTION
12	H100759	SCREW SELF TAPPING 1/4x1

REPEAT ON ALL FOUR CORNERS

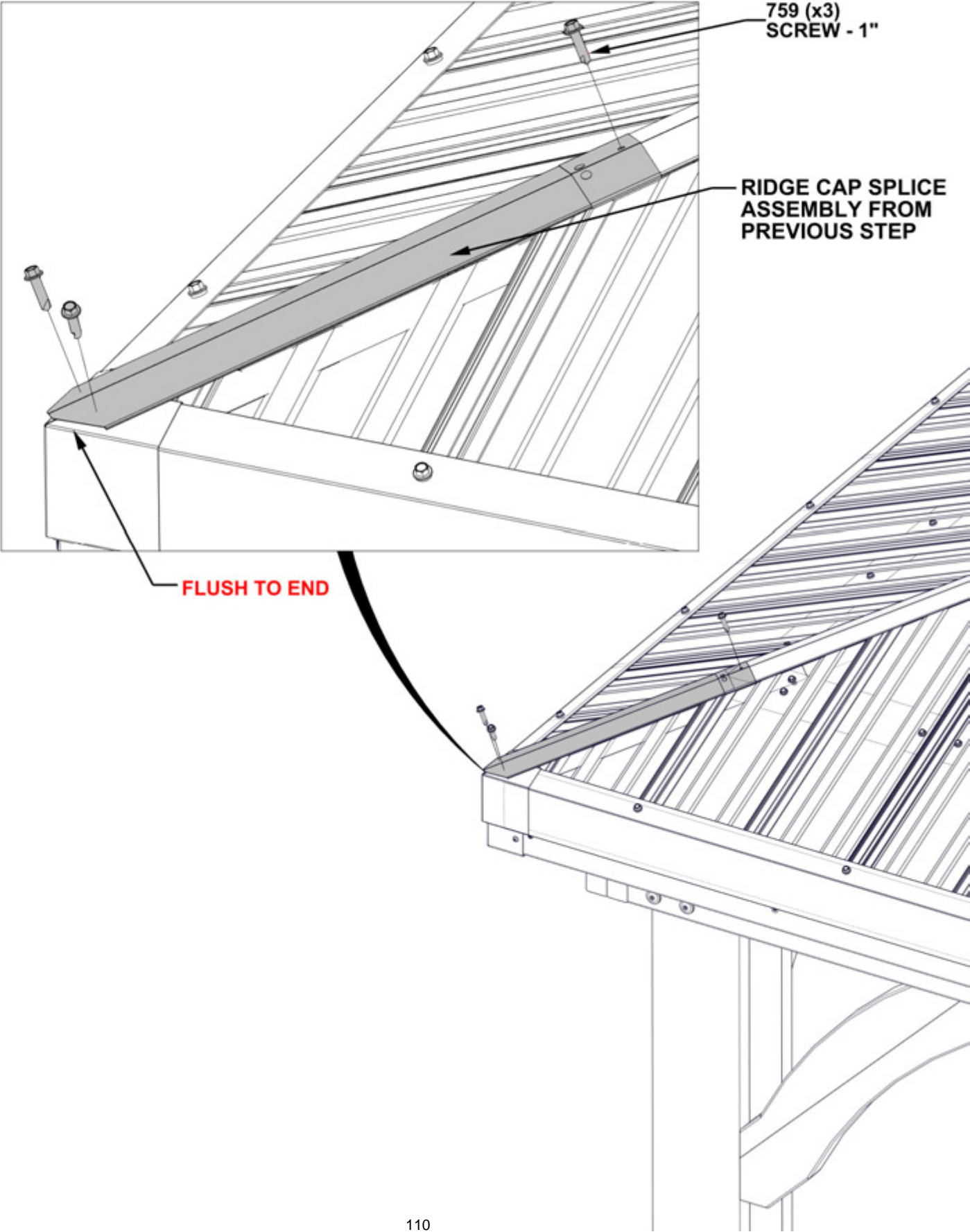

STEP 90 - ROOF TRIM

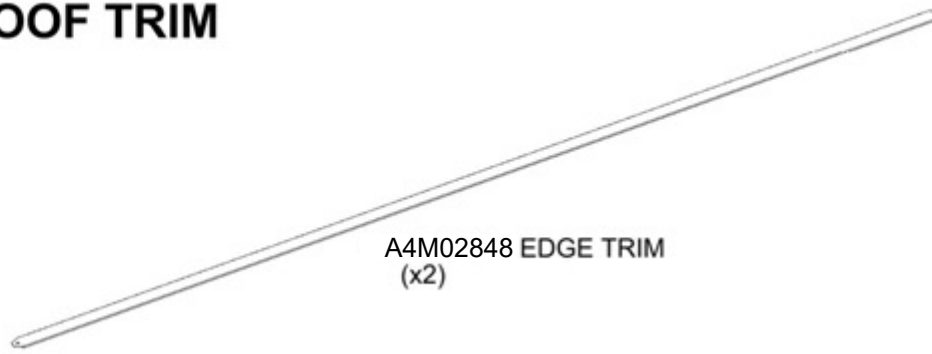

- TIPS:
- SLIDE EDGE TRIM ONTO ROOF RIDGE CAP CHANNEL AS SHOWN.
 - DO NOT PUSH ALL THE WAY TO THE TOP. FLUSH WITH EDGE OF GAZEBO.

REPEAT ON BOTH SIDES

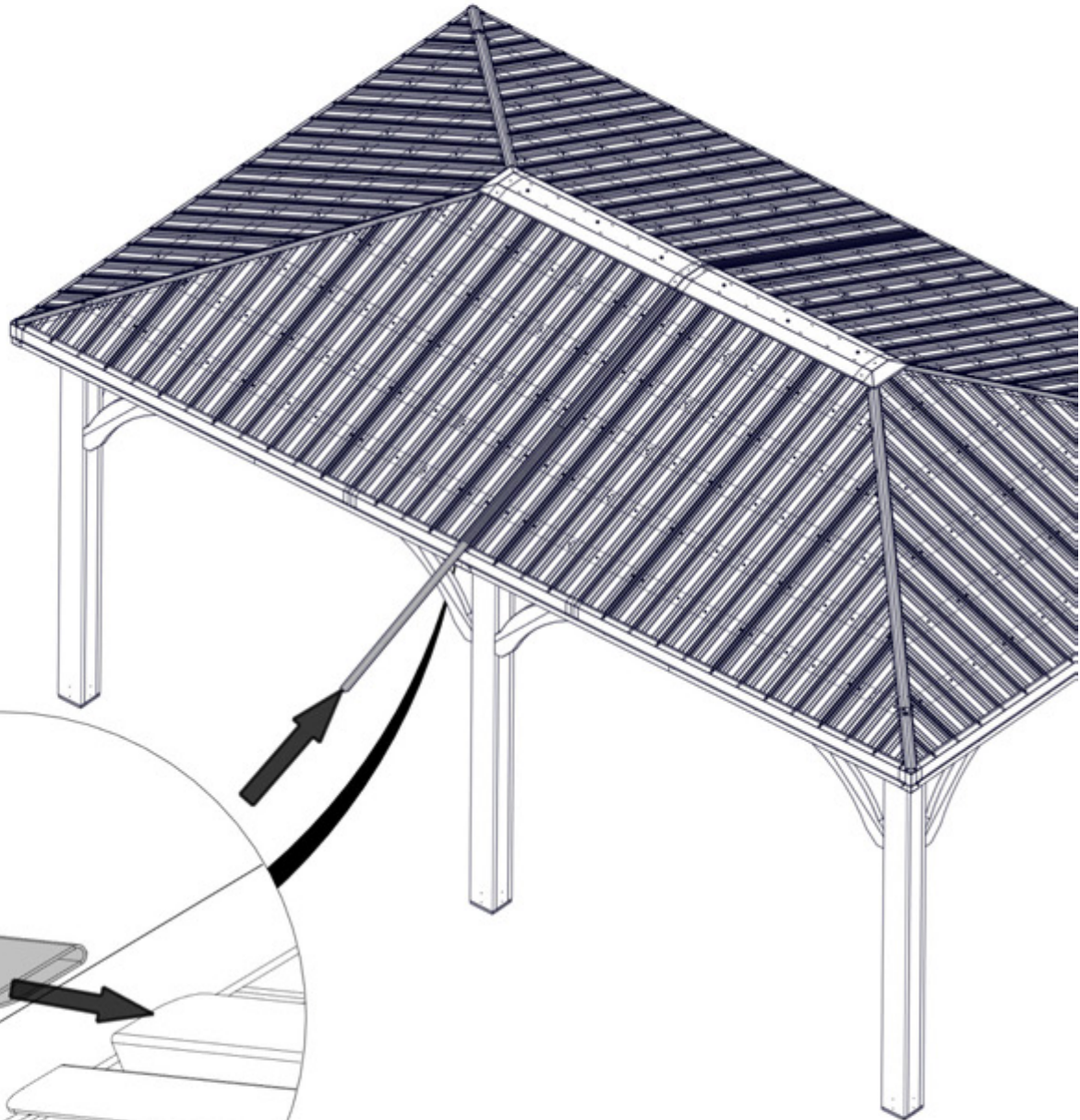

2848 (x1)
EDGE TRIM

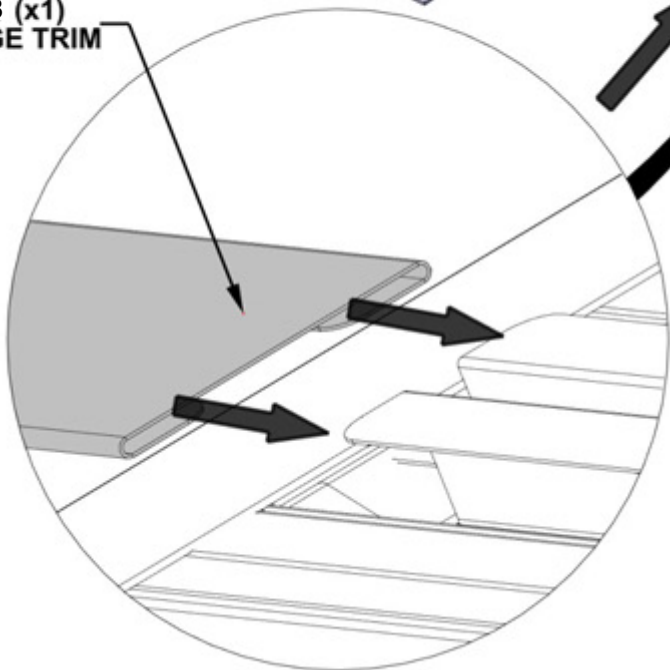

STEP 91 - ROOF TRIM

QTY	PART NUMBER	DESCRIPTION
2	H100759	SCREW SELF TAPPING 1/4x1

REPEAT ON BOTH SIDES

759 (x1)
SCREW - 1"

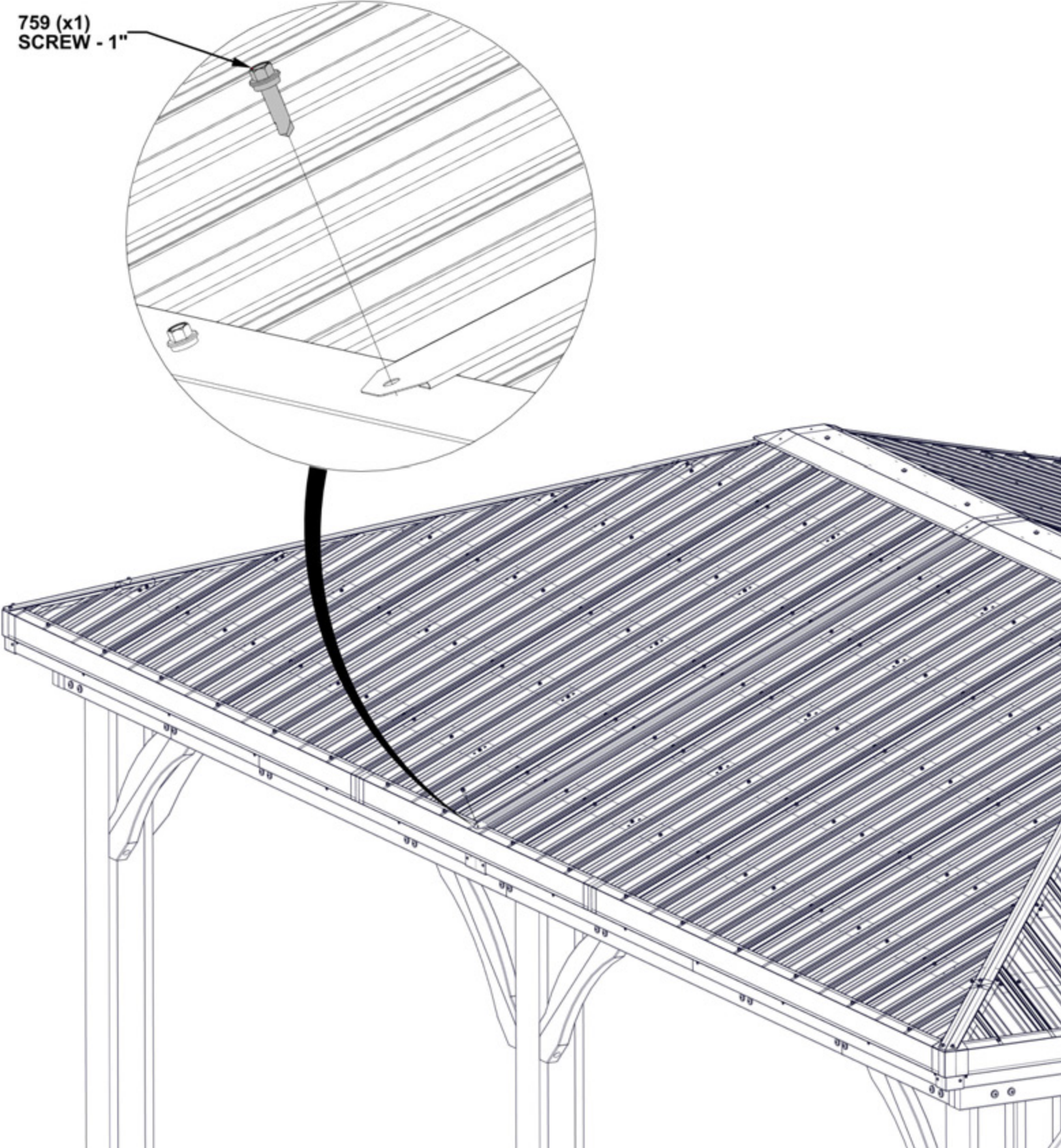

STEP 92 - GAZEBO ASSEMBLY

QTY	PART NUMBER	DESCRIPTION
48	H100471	LAG SCREW WH 5/16x1 1/2 BLK



A4M01793 POST ANCHORING PLATE
(x12)



A4M01794 POST PLATE
(x12)

USE PILOT HOLES IN POSTS TO ATTACH POST PLATES.

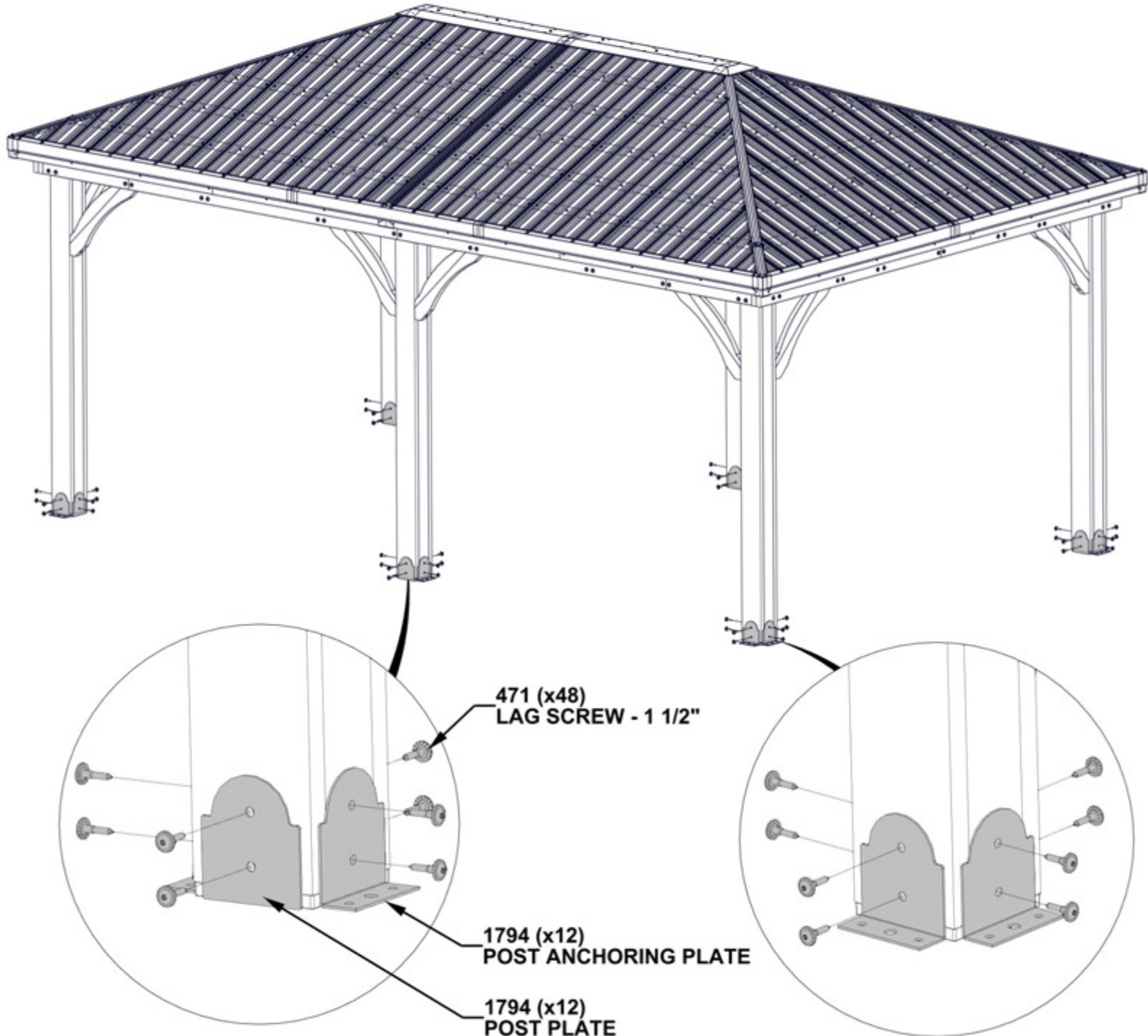

STEP 93 - GAZEBO ASSEMBLY



A4M02158
BYD ID TAG PATIO
(x1)

QTY	PART NUMBER	DESCRIPTION
4	H100200	SCREW PFH 8x1 1/2 BLK

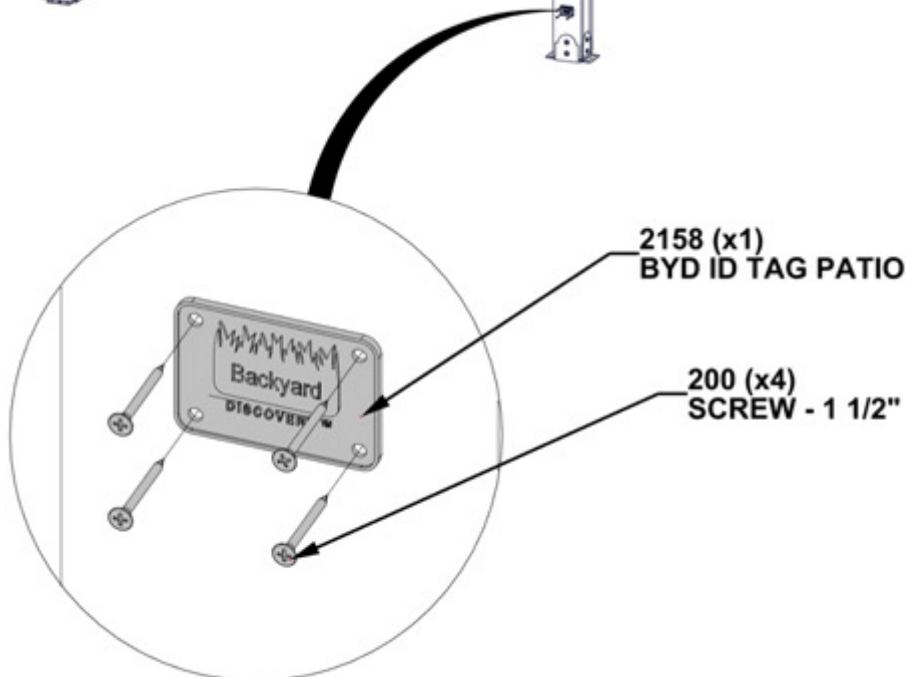

STEP 94 - GAZEBO ASSEMBLY

QTY	PART NUMBER	DESCRIPTION
24	H100120	CONCRETE ANCHOR 1/4"x2"
24	H100630	WASHER FLAT 8x19 BLK

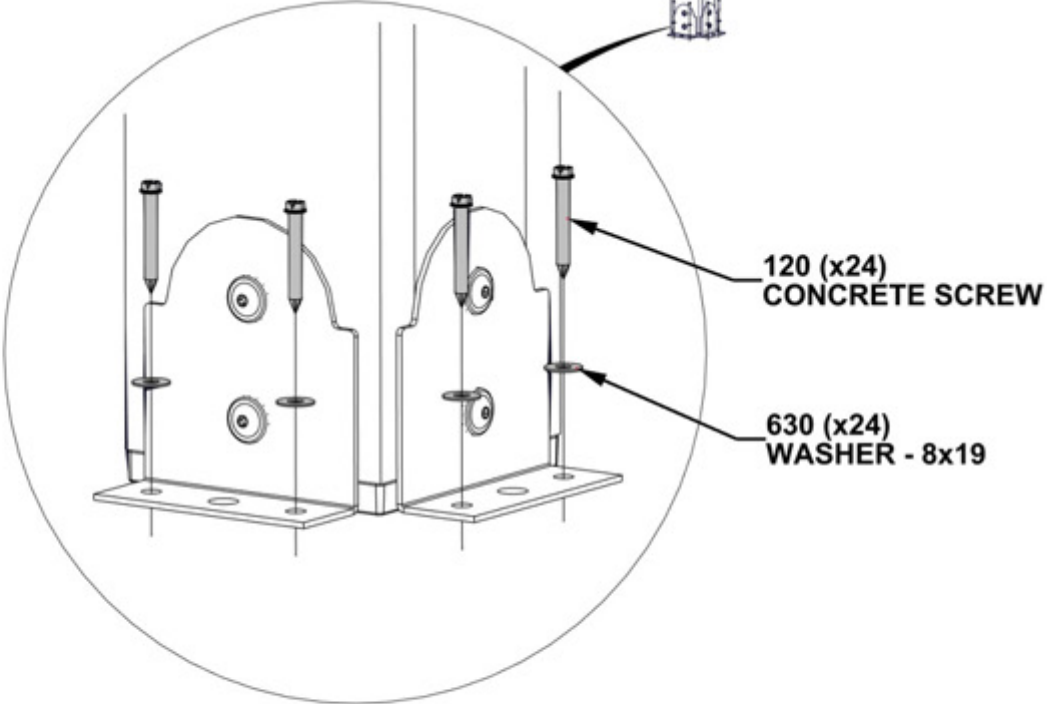
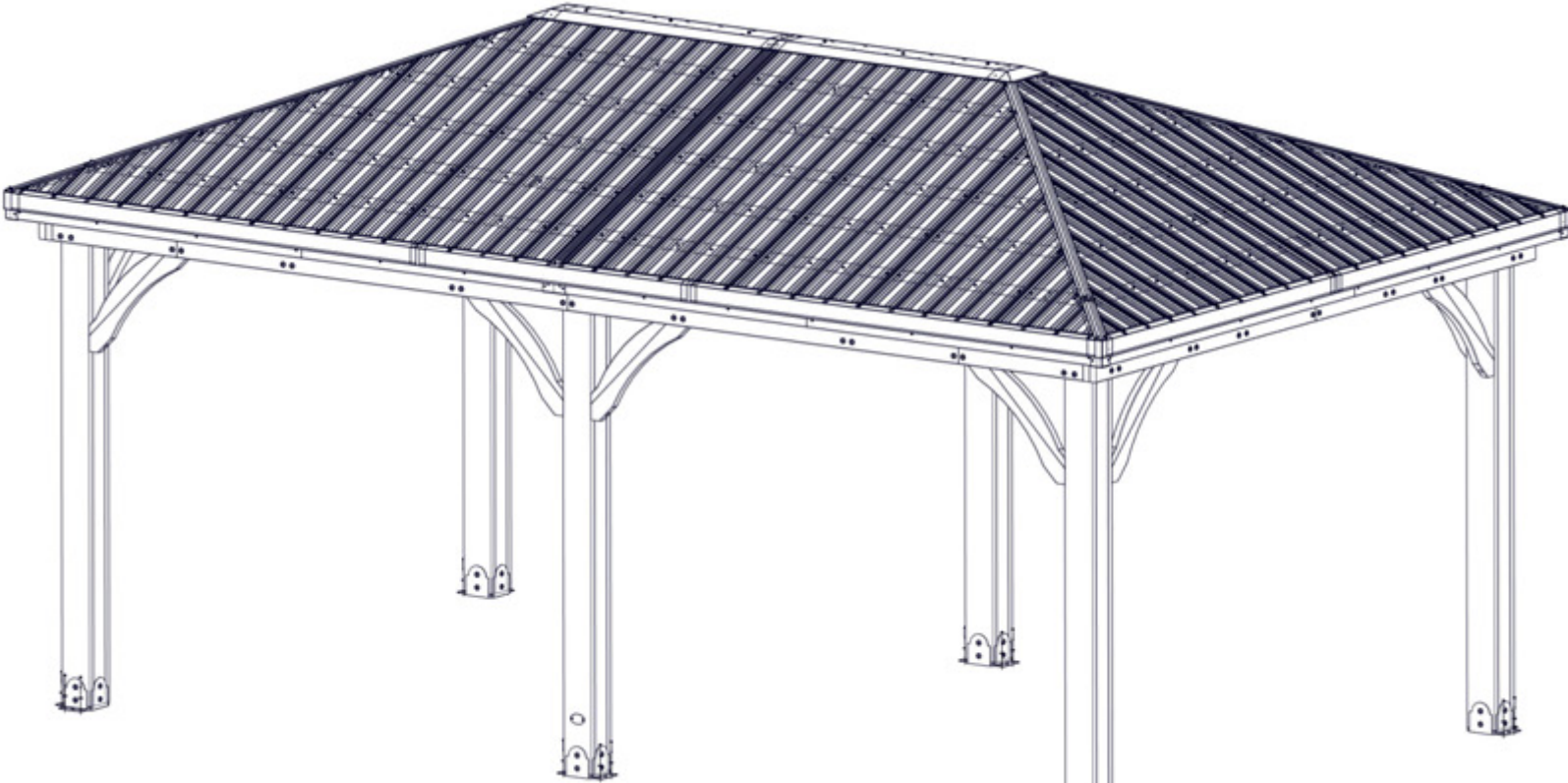

STEP 95 - GAZEBO ASSEMBLY (OPTIONAL)

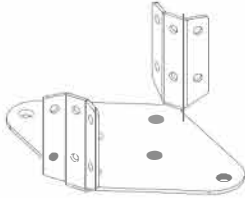

QTY	PART NUMBER	DESCRIPTION
4	H100382	SCREW PFH 8x1 3/4 BLK

A4M02501 FAN MOUNT BRACKET
(x1)

- ATTACH YOUR ELECTRICAL BOX (SOLD SEPERATELY) WITH THE PROVIDED HOLES IN FAN MOUNT BRACKET.
- PLACE FAN MOUNT BRACKET ON RIDGE BEAMS AND MOVE TO DESIRED FAN LOCATION.
- ROTATE BRACKET UNTIL MOUNTING FLANGES ALIGN BEST WITH RIDGE BEAMS.
- USE AN 1/8" (3mm) DRILL BIT AND DRILL PILOT HOLES AND ATTACH AS SHOWN.

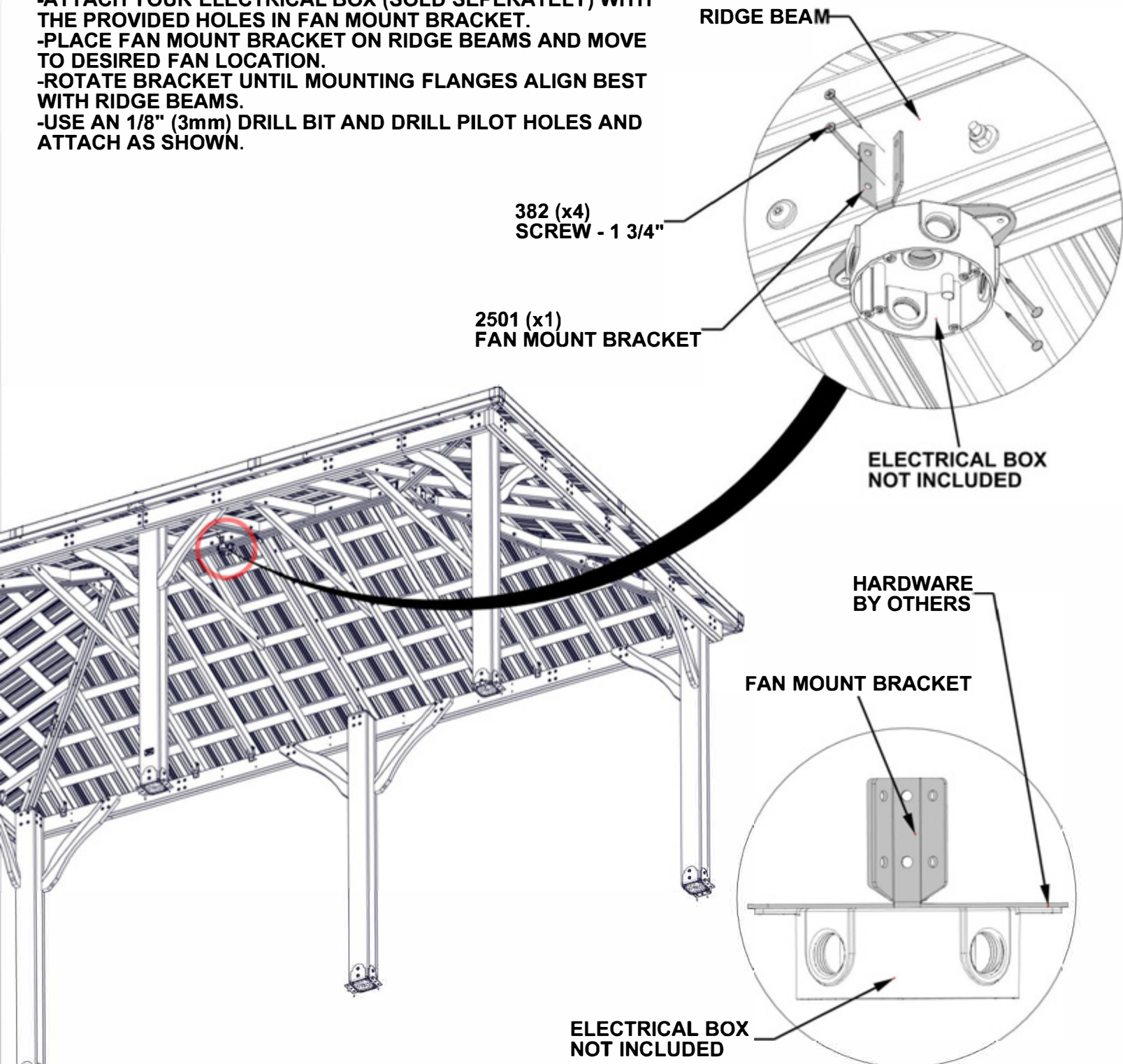

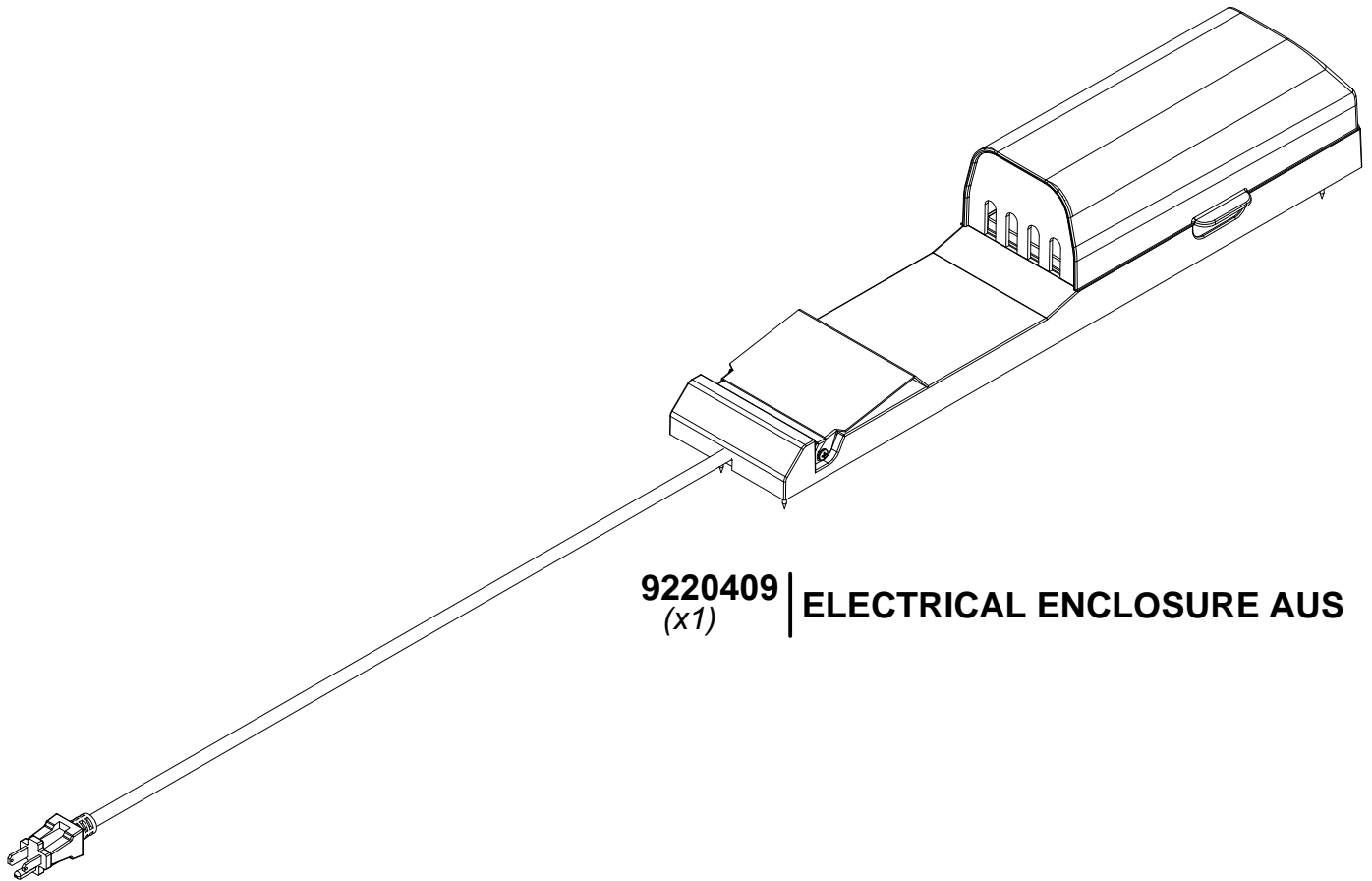

9220409 | **ELECTRICAL ENCLOSURE AUS**
(x1)

FOR POWERPORT INSTALLATION REFER TO ASSEMBLY INSTRUCTIONS THAT COME PACKAGED WITH THE POWERPORT KIT. INSTALL ON ANY POST THAT IS DESIRED. FOLLOW DIRECTIONS FOR PROPER INSTALLATION.