



Manufactured by:
Backyard Discovery
3305 Airport Drive, Pittsburg, KS 66762
800-856-4445

Basepoint Business Centre: Rivermead Drive, Westlea, Swindon SN5 7EX Phone: 0800-118-2476
J.P. Coenstraat 7, The Bridge, The Hague, 2595 WP, Netherlands Phone: 08005678990

12x10 LOUVERED PERGOLA

MODEL # : 2407053D



Please visit www.backyarddiscovery.com
For the most up to date assembly manual, to register your product, or to order replacement parts *Para obtener instrucciones en español, visite*
www.backyarddiscovery.com



EASY STEP-BY-STEP
3D INTERACTIVE INSTRUCTIONS
DOWNLOAD THE FREE APP



OWNER'S MANUAL - BASIC SETUP DIMENSIONS & ASSEMBLY NOTES

It is critically important that you start with square and level footings, concrete pad or deck to attach your structure

- Pay close attention to the items needed for each step. Make sure you are using the correct hardware for each step.
- Using incorrect hardware may result in improper assembly
- Remember to double check for underground utilities and overhead electrical lines

Post mounts are provided with your structure which allows you to permanently install your structure to a pre-existing or new wood or concrete surface. See Anchor Instructions for further details and recommendations.

- The hardware to attach the post mounts to the structure is included.
- The hardware to mount the structure permanently to a concrete surface is included.
- The hardware to mount the structure permanently to a wood deck is NOT included and will need to be purchased separately. You must ensure there is ample structural support under the deck before permanently attaching.

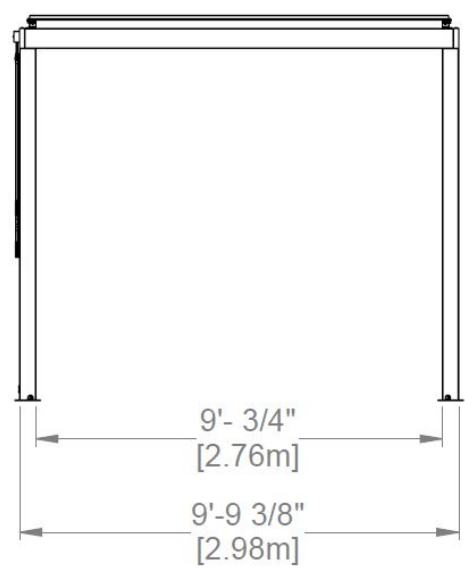
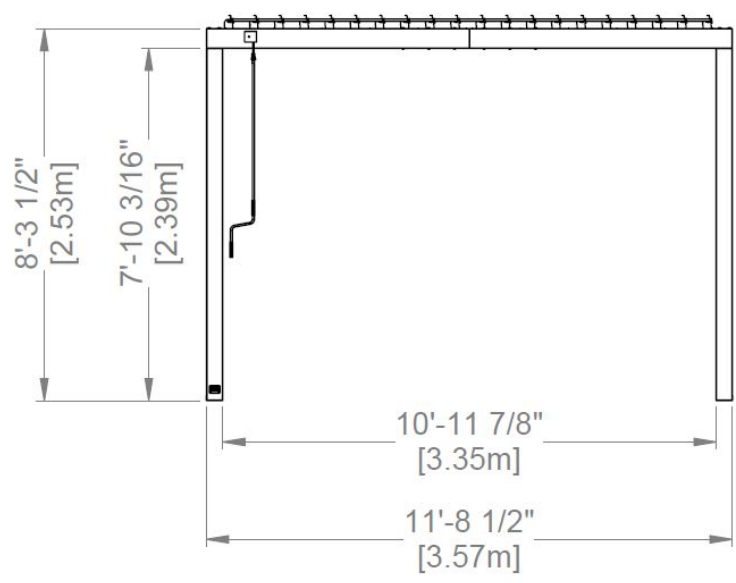
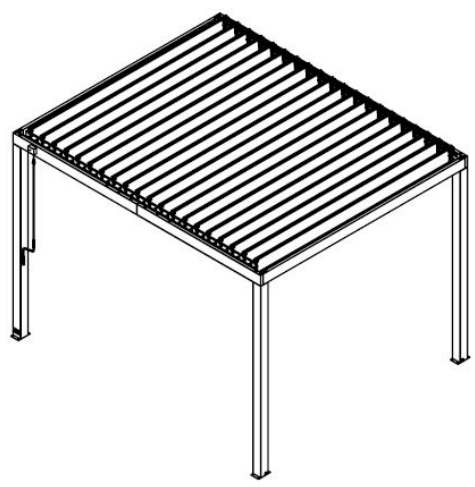
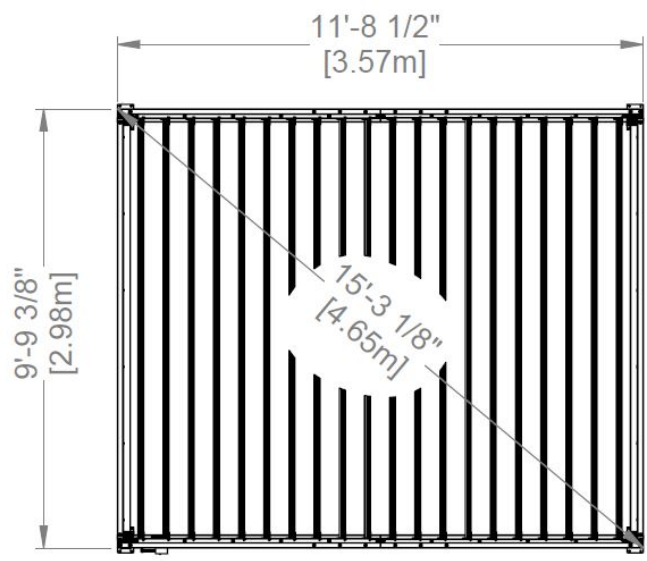

OWNER'S MANUAL - ANCHORING LAYOUT

NOTE: DIMENSIONS ARE TO ANCHOR PLATE ON BOTTOM OF POST EXCEPT WHERE NOTED.

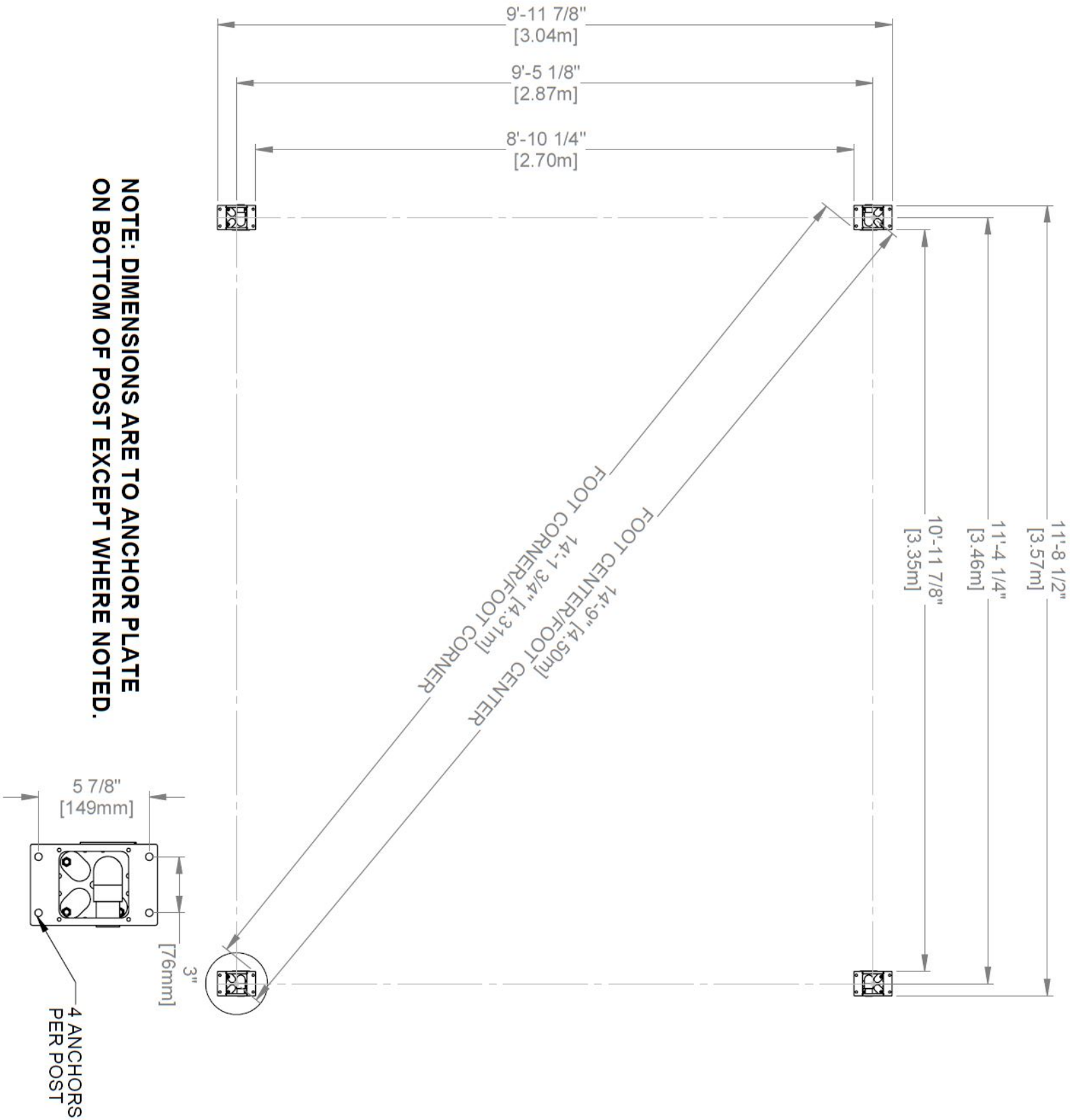

OWNER'S MANUAL - PARTS IDENTIFICATION

METAL COMPONENTS (NOT TO SCALE)

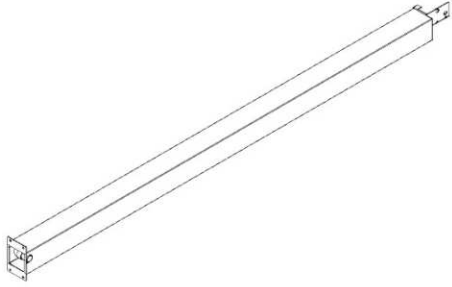

P01 POST - A4M01983
(x1) 4 5/16"x6 3/4"x99 1/2" (110x172x2527)

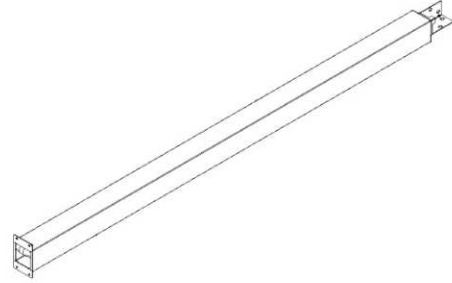

P02 POST - A4M01984
(x2) 4 5/16"x6 3/4"x99 1/2" (110x172x2527)

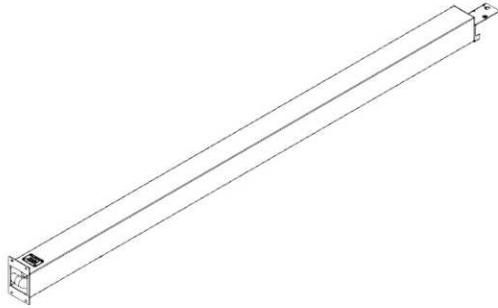

P03 POST - A4M02131
(x1) 4 5/16"x6 3/4"x99 1/2" (110x172x2527)

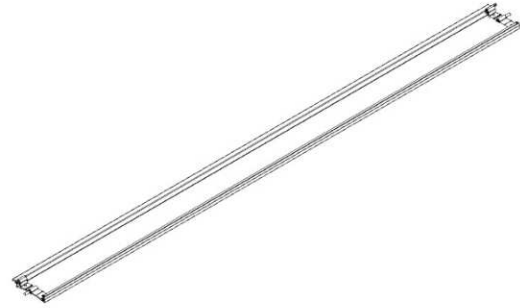

L01 LOUVER - A4M04137
(x20) 1 11/16"x7 3/4"x114 5/16" (42x196x2904)



G01 GUTTER - A4M01993
(x2) 1 9/16"x1 15/16"x108 7/8" (40x50x2765)

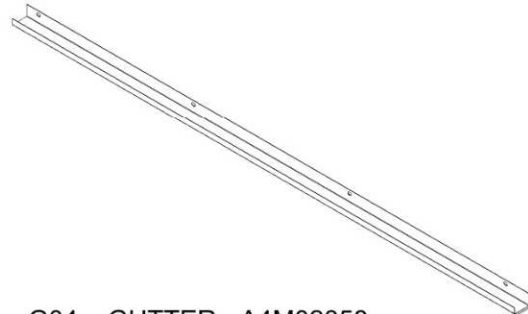

G04 GUTTER - A4M02858
(x2) 1 9/16"x1 15/16"x65 15/16" (40x50x1675)

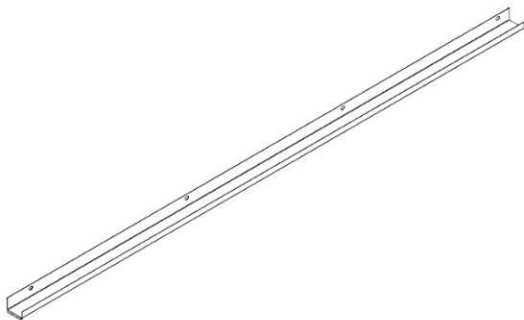

G03 GUTTER - A4M02857
(x2) 1 9/16"x1 15/16"x65 15/16" (40x50x1675)

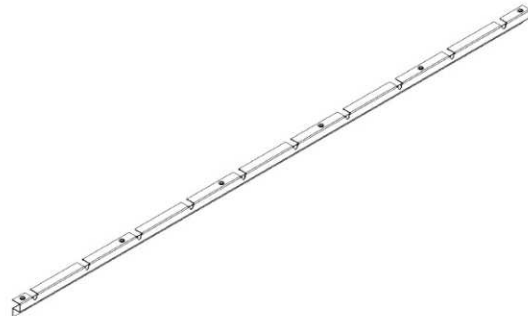

M01 LOUVER MOUNT - A4M02864
(x2) 1"x1 15/16"x65 7/8" (25x49x1673)

OWNER'S MANUAL - PARTS IDENTIFICATION

METAL COMPONENTS (NOT TO SCALE)

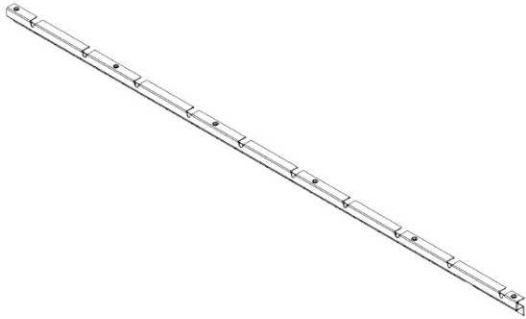

M02 LOUVER MOUNT - A4M02865
(x1) 1"x1 15/16"x65 7/8" (25x49x1673)

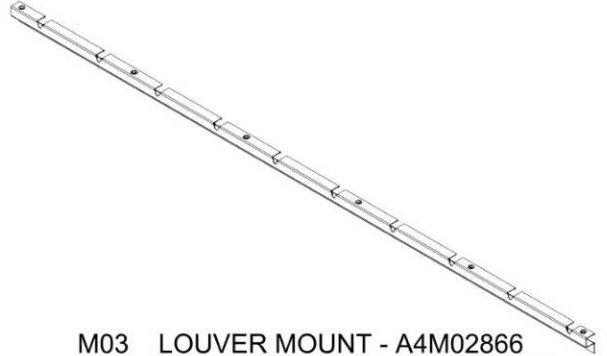

M03 LOUVER MOUNT - A4M02866
(x1) 1"x1 15/16"x65 7/8" (25x49x1673)



F01 FLAT BAR - A4M02859
(x4) 1/16"x1"x65 7/8" (2x25x1673)

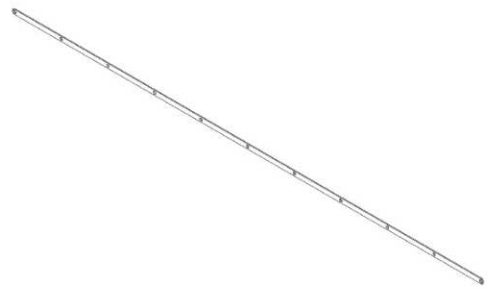

F02 LOUVER TIE STRAP - A4M02860
(x4) 1/8"x13/16"x68 1/16" (3x20x1730)



B01 BEAM - A4M01986
(x2) 1 7/16"x5 1/4"x114 1/2" (36x134x2910)



B02 BEAM - A4M02861
(x1) 1 7/16"x5 1/4"x70 1/4" (36x134x1784)



B03 BEAM - A4M02862
(x2) 1 7/16"x5 1/4"x70 1/4" (36x134x1784)



B04 BEAM - A4M02863
(x1) 1 7/16"x5 1/4"x70 1/4" (36x134x1784)



J1 SPLICE BRACKET - A4M02230
(x2) 1 5/16"x5 3/16"x39 3/8" (33.2x131.2x1000)

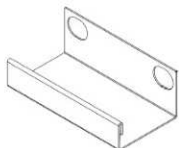

G05 GUTTER SPLICE - A4M02004
(x2) 1 7/16"x2 1/16"x3 15/16" (36x52.5x100)



F06 SPACER - A4M02227
(x1) 1/16"x2 3/16"x2 3/4" (1.5x56x70)



A6P00796 SILICONE
(x1)

OWNER'S MANUAL - PARTS IDENTIFICATION

METAL COMPONENTS (NOT TO SCALE)



L02 LOUVER DRIVE SIDE PLATE - A4M04139
(x1) 1/16"x2 3/16"x6 9/16" (2x55x167)

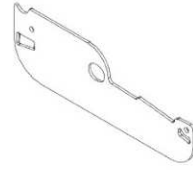

L03 LOUVER SIDE PLATE - A4M04138
(x39) 1/16"x2 3/16"x6 9/16" (2x55x167)



F05 KEY STOCK - A4M02226
(x1) 1/2"x1 1/2"x3 3/4" (13x13x95)

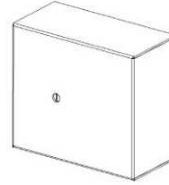

F07 COVER - A4M02228
(x1) 1 9/16"x2 7/8"x3 1/4" (39.5x73x82)

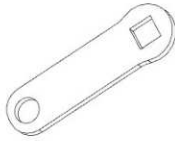

F04 LINKAGE STRAP - A4M02225
(x1) 1/8"x13/16"x2 5/8" (3x20x66)

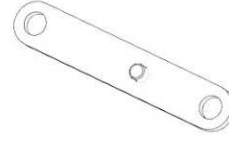

F03 LINKAGE STRAP - A4M02229
(x1) 1/2"x11/16"x3 13/16" (13x17x97)



L04 LOUVER MECHANISM
(x1) A4M02132



H01 HANDLE
(x1) A4M04022

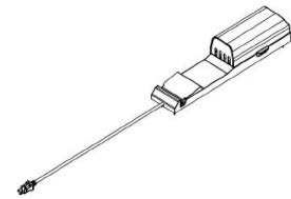

9250154 ELECTRICAL
(x1) ENCLOSURE

OWNER'S MANUAL - PARTS IDENTIFICATION

HARDWARE COMPONENTS

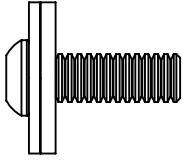

H101202 | TORX PAN HEAD 1/4-20x3/4 ASSY
(x116) | 1/4-20x3/4 ASSY

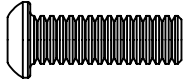

H101101 | TORX PAN HEAD
(x1) | 1/4-20x3/4" BLK

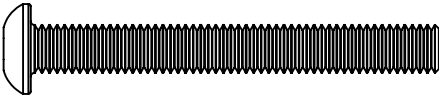

H101126 | TORX PAN HEAD
(x4) | 1/4-20x2 1/8" BLK



H101187 | BOLT PPH
(x1) | 8-32x1 1/8" BLK

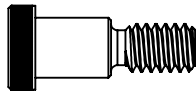

H101189 | LOW PROFILE SHOULDER BOLT
(x2) | 1/4-20x3/8" BLK

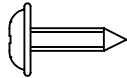

H100408 | SCREW PWH
(x80) | 8x1/2 BLK

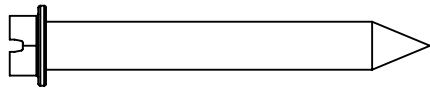

H100120 | CONCRETE ANCHOR
(x16) |

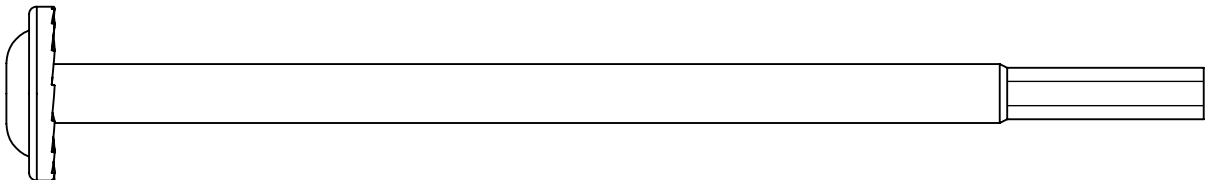

H101230 | BOLT WH
(x16) | 5/16x6 S.S

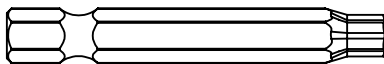

H100147 | TORX BIT
(x1) | T-30

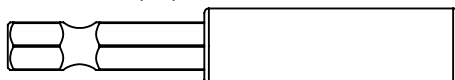

H101100 | MAGNETIC DRIVER
(x1) |

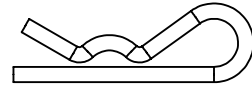

H101161 | COTTER PIN
(x40) |

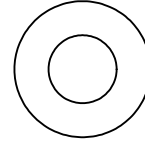

H100474 | WASHER FLAT
(x5) | 9x19 BLK

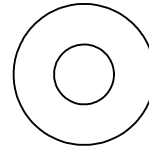

H100630 | WASHER FLAT
(x16) | 8x19 BLK



H100653 | NUT LOCK
(x2) | 1/4 BLK

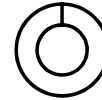

H100774 | WASHER SPLIT
(x1) | 1/4 BLK

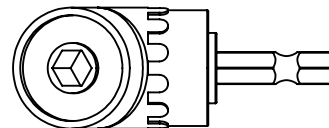

H101114 | RIGHT ANGLE DRILL ADAPTER
(x1) |



H100114 | TORX WRENCH
(x1) | T-30

PRE-ASSEMBLY STEP 1 - SORTING PARTS

It is critical for ease of assembly that you take the time to sort and organize the parts and hardware.

METAL PARTS:

- Organize metal parts by the three-digit, alpha-numeric number stamped on each bag (ex. P01).
- If there are multiple parts with the same stamped number, stack those pieces together.
- Stamps can be found on the flat surface of the parts or on the end of the parts.
- Allow yourself plenty of room - the parts can take up a significant amount of space.

NOTE: CARTONS ARE NOT ORGANIZED BY PART NUMBER.

IT IS RECOMMENDED TO LEAVE LOUVER ASSEMBLIES IN BOX UNTIL NEEDED.

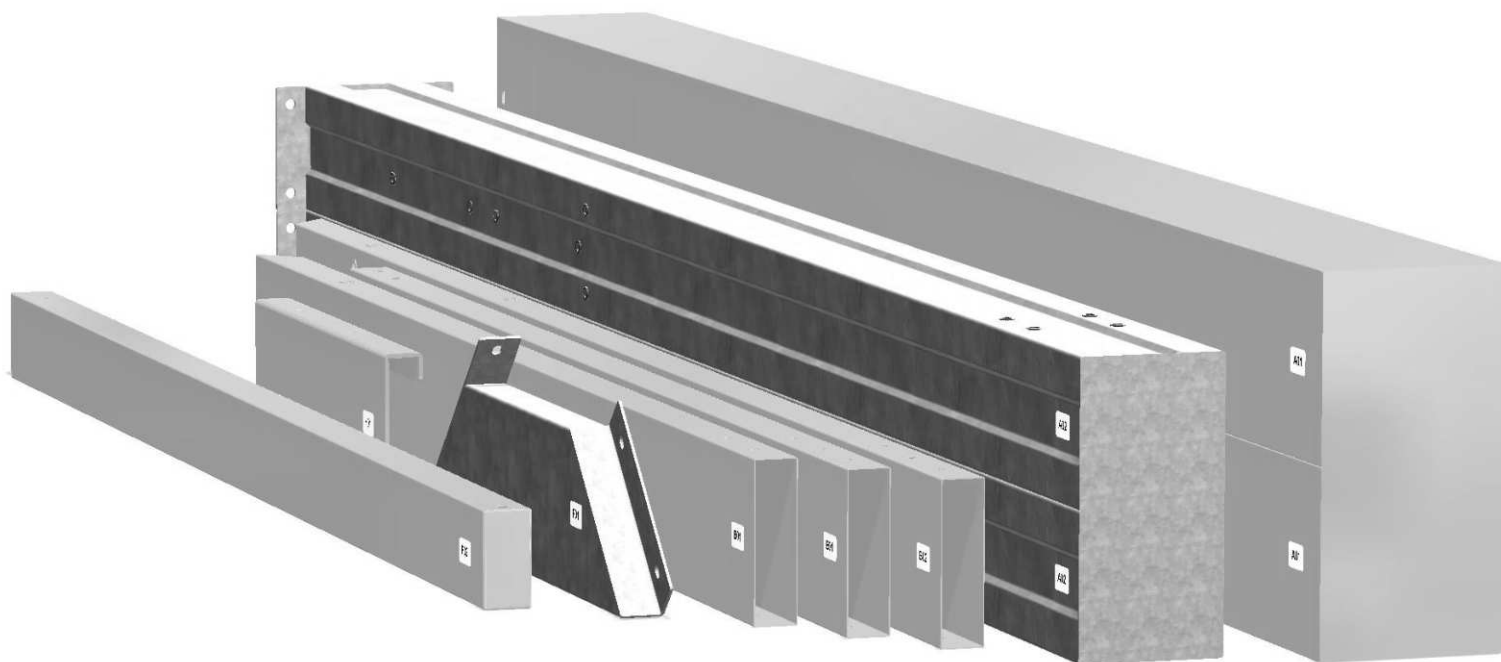

HARDWARE PARTS:

- We recommend that you have a separate table to organize the hardware.
- Hardware bags are printed with a seven-digit, alpha-numeric part number.
- You can organize your hardware by part number or group by hardware type (i.e. bolts, nuts, etc.).
- During assembly you only need to reference the last four digits of the number.

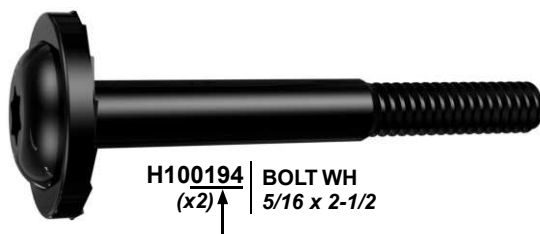

PRE-ASSEMBLY STEP 2 - TOOLS REQUIRED



Cordless Drill or Electric Drill



Drill Attachments:
Phillips Head



1/8", 3/16", 3/8" & 7/16" Drill Bits



Phillips Screw Driver



Open End Wrench
7/16"



3/8" Drive Ratchet, 1/2" & 7/16" STD Sockets 1/2" & 7/16" Deep Sockets



Claw Hammer



Rubber Mallet -
Optional

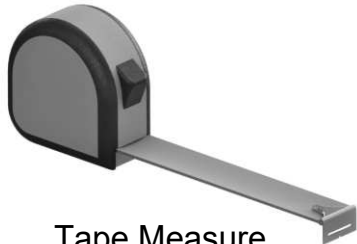

Tape Measure

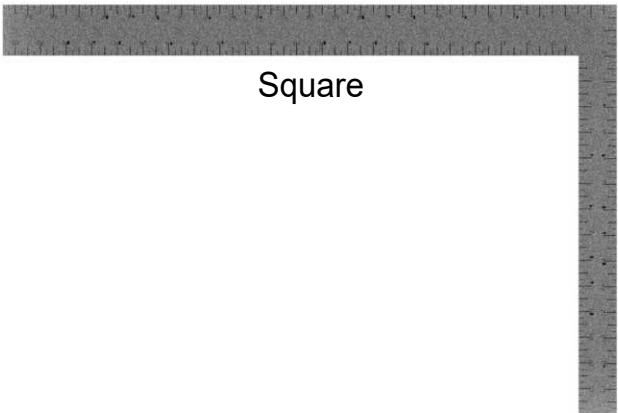

Square



Level 24"

PRE-ASSEMBLY STEP 3 - CHOOSE YOUR ASSEMBLY METHOD

There are several types of assembly instructions available to you.

1. Printed Assembly Manual included with your set
2. BILT APP - 3D interactive instructions
3. Combination of the Printed Manual and BILT APP (Note: Step numbers can differ between the two methods)



BILT.

Scan for easy
3D instructions

Download the BILT app
before you begin



Download on the
App Store

GET IT ON
Google Play

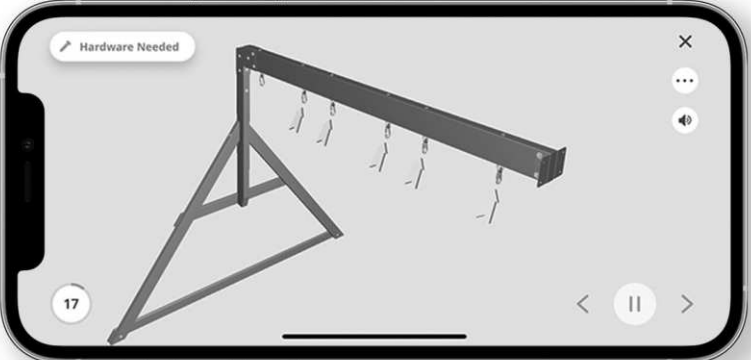

Hardware Needed

17

< || >

The image shows a smartphone screen displaying a 3D assembly instruction. The screen features a 3D model of a metal frame with a horizontal beam and several hanging components. A 'Hardware Needed' button is visible in the top left corner of the app interface. The number '17' is shown in a circle in the bottom left corner, indicating the current step. Navigation controls, including a back arrow, a pause button, and a forward arrow, are located at the bottom of the screen.

STEP 1 - BEAM ASSEMBLY

QTY	PART NUMBER	DESCRIPTION
6	H101202	TORX PAN HEAD 1/4-20x3/4 ASSY



B03 BEAM - A4M02862
(x1) 1 7/16"x5 1/4"x70 1/4" (36x134x1784)



J1 SPLICE BRACKET - A4M02230
(x1) 1 5/16"x5 3/16"x39 3/8" (33.2x131.2x1000)

- FOR EASE OF ASSEMBLY, WE RECOMMEND USING SAWHORSES FOR STEPS 1-7.

- BEAM AND SPLICE MUST BE ORIENTED AS SHOWN BELOW. SLIDE J1 INTO B03 AND LINE UP THREE HOLES TOP AND BOTTOM.

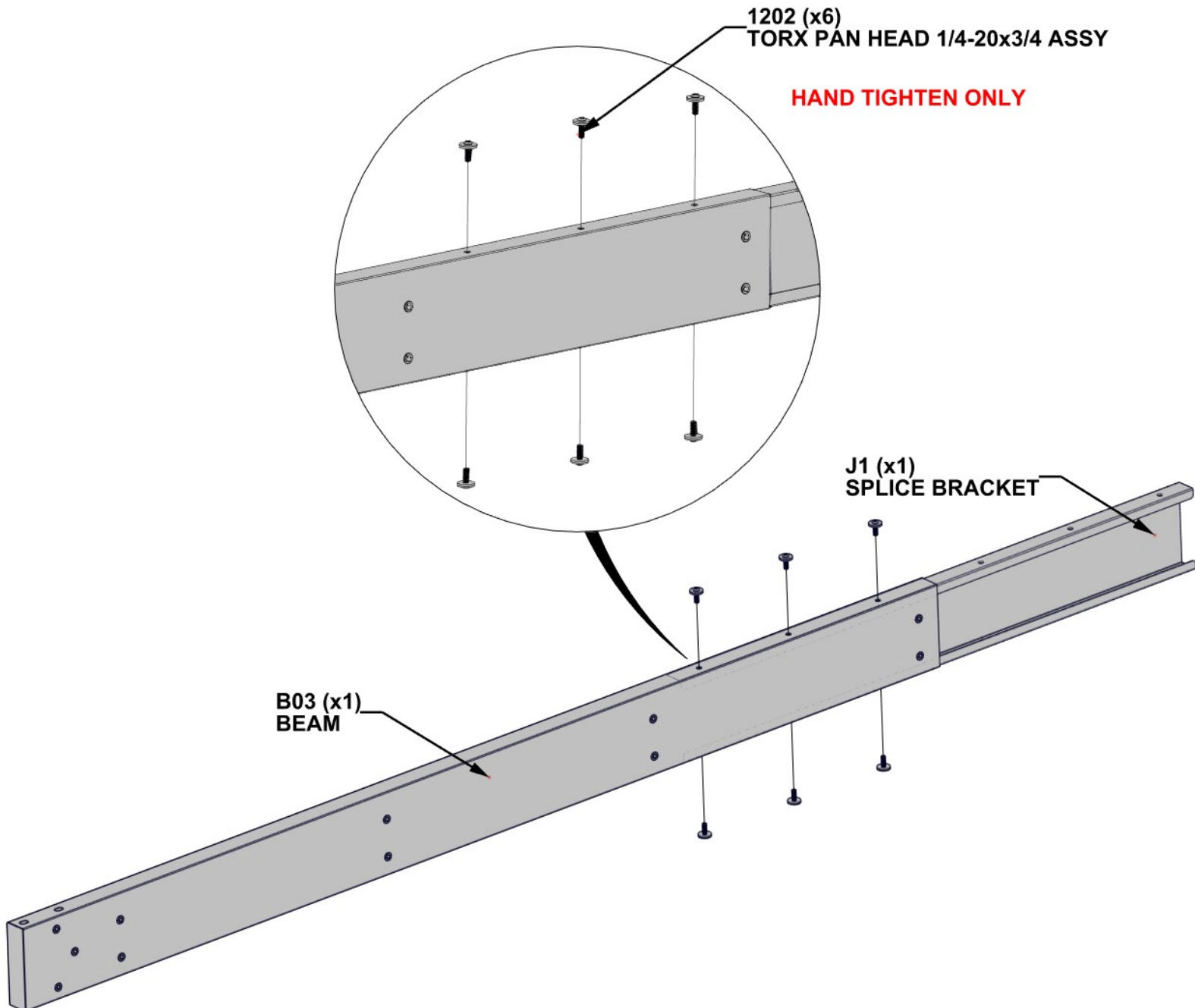

STEP 2 - BEAM ASSEMBLY

QTY	PART NUMBER	DESCRIPTION
6	H101202	TORX PAN HEAD 1/4-20x3/4 ASSY



B02 BEAM - A4M02861
(x1) 1 7/16"x5 1/4"x70 1/4" (36x134x1784)

**- SLIDE B02 INTO SPLICE BRACKET.
GENTLY TAP ENDS OF ASSEMBLY WITH
RUBBER Mallet UNTIL GAP CLOSES.**

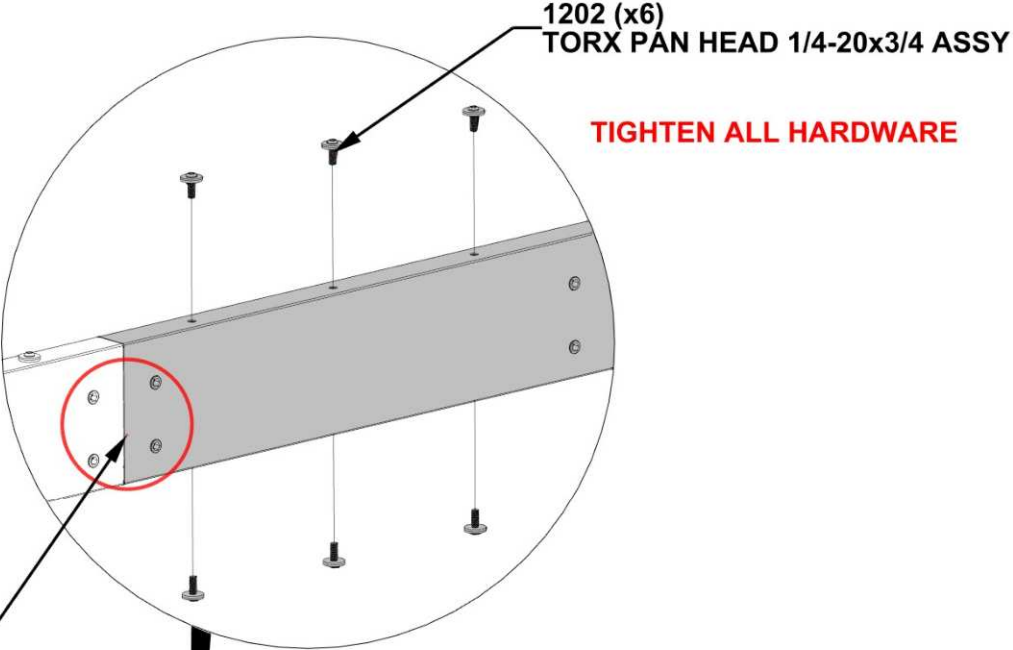

**NOTE: ALL THREADED INSERTS
WILL BE ON THE SAME SIDE OF
THE BEAM**

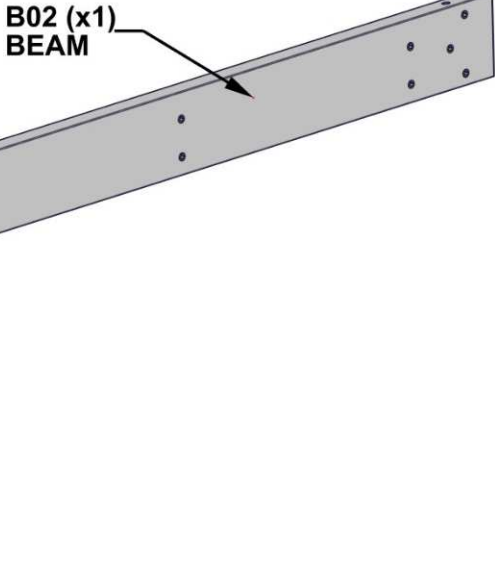

STEP 3A - FRAME ASSEMBLY

QTY	PART NUMBER	DESCRIPTION
2	H101230	BOLT WH 5/16x6 S.S.

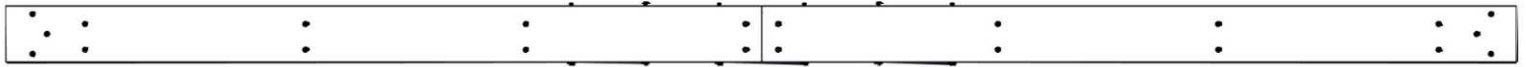
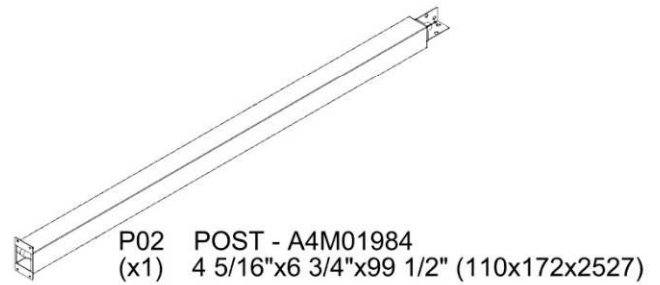

BEAM ASSEMBLY
STEP 1 - 2

- ATTACH BEAM ASSEMBLY TO POST BY ALIGNING SLOTS IN BEAM WITH THREADED INSERTS ON TOP POST PLATE. FLUSH ALL SIDES OF BEAM AND POST BEFORE TIGHTENING HARDWARE.

NOTE: LARGE SLOTS INDICATE BOTTOM SURFACE OF BEAM. SLOTS WILL FIT AROUND THREADED INSERTS IN POST PLATE.

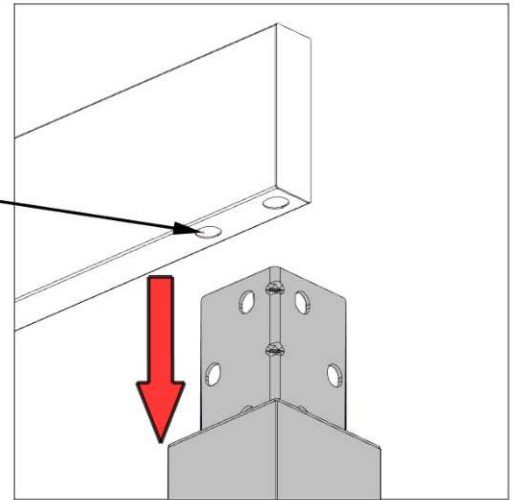

BACK VIEW

NOTE: POST BRACKET WILL FIT AROUND THREADED INSERTS IN BEAM

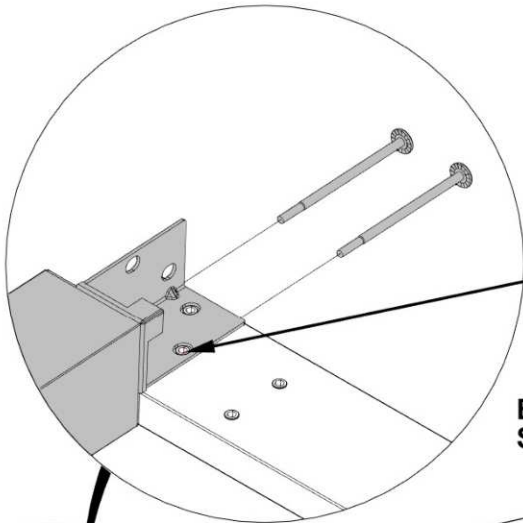

BEAM ASSEMBLY
STEP 1 - 2

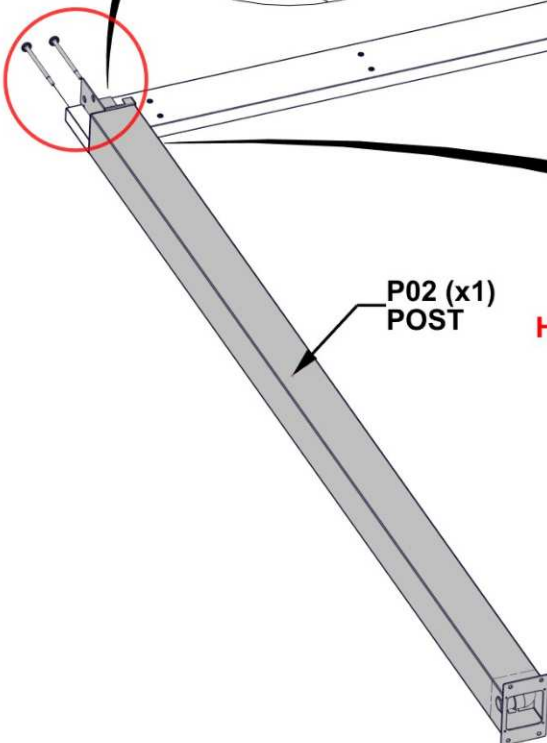

P02 (x1)
POST

HAND TIGHTEN ONLY

1230 (x2)
BOLT - 6"

FLUSH

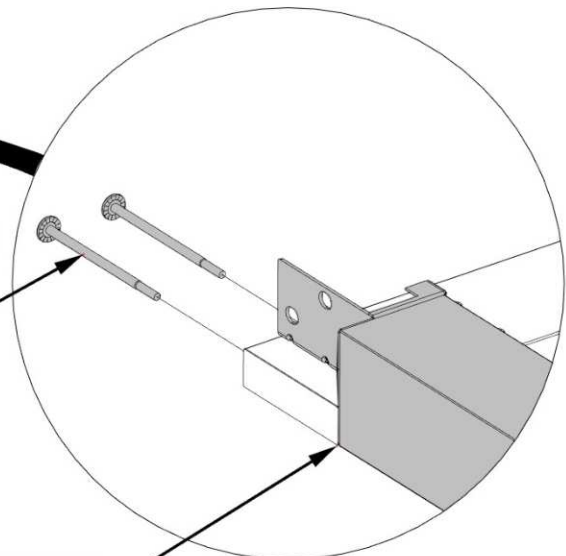

STEP 3B - FRAME ASSEMBLY

QTY	PART NUMBER	DESCRIPTION
3	H101202	TORX PAN HEAD 1/4-20x3/4 ASSY

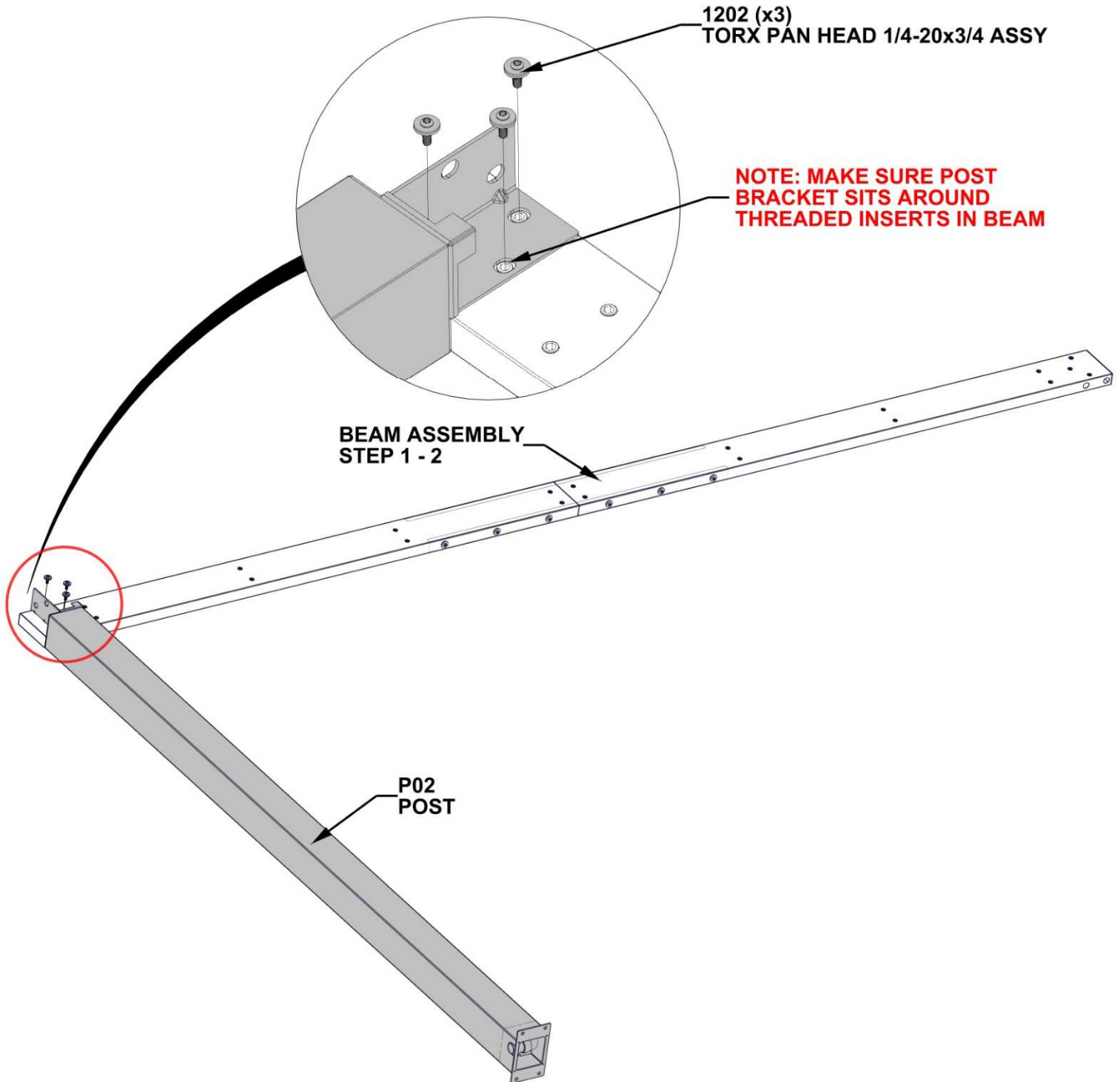

STEP 4A - FRAME ASSEMBLY

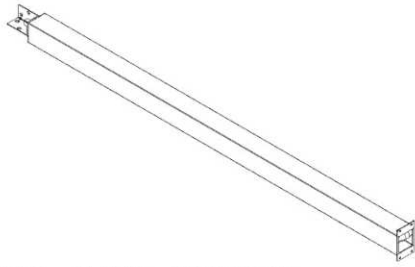

QTY	PART NUMBER	DESCRIPTION
2	H101230	BOLT WH 5/16x6 S.S.

P01 POST - A4M01983
(x1) 4 5/16"x6 3/4"x99 1/2" (110x172x2527)

- ATTACH BEAM TO POST BY ALIGNING SLOTS IN BEAM WITH THREADED INSERTS ON TOP POST PLATE. FLUSH ALL SIDES OF BEAM AND POST BEFORE TIGHTENING HARDWARE.

NOTE: LARGE SLOTS INDICATE BOTTOM SURFACE OF BEAM. SLOTS WILL FIT AROUND THREADED INSERTS IN POST PLATE.

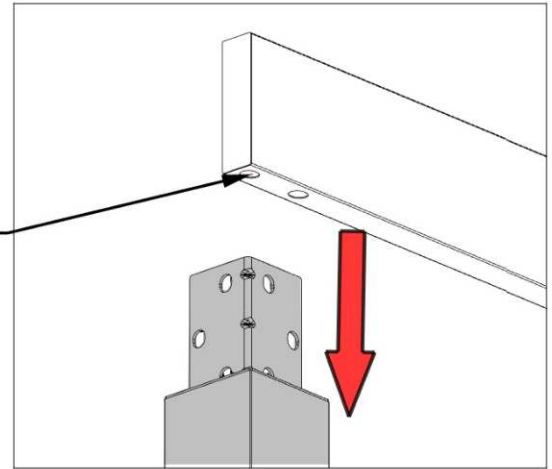

BACK VIEW

NOTE: POST BRACKET WILL FIT AROUND THREADED INSERTS IN BEAM

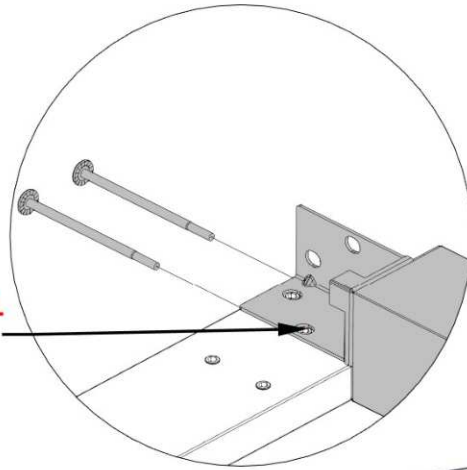

BEAM ASSEMBLY
STEP 1 - 2

P01 (x1)
POST

1230 (x2)
BOLT - 6"

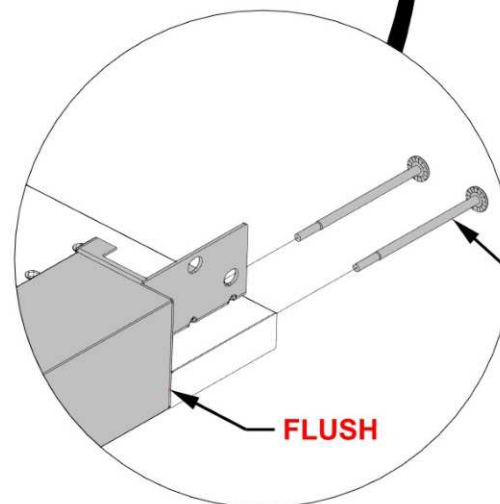

FLUSH

STEP 4B - FRAME ASSEMBLY

QTY	PART NUMBER	DESCRIPTION
3	H101202	TORX PAN HEAD 1/4-20x3/4 ASSY

1202 (x3)
TORX PAN HEAD 1/4-20x3/4 ASSY

**NOTE: MAKE SURE POST
BRACKET SITS AROUND
THREADED INSERTS IN BEAM**

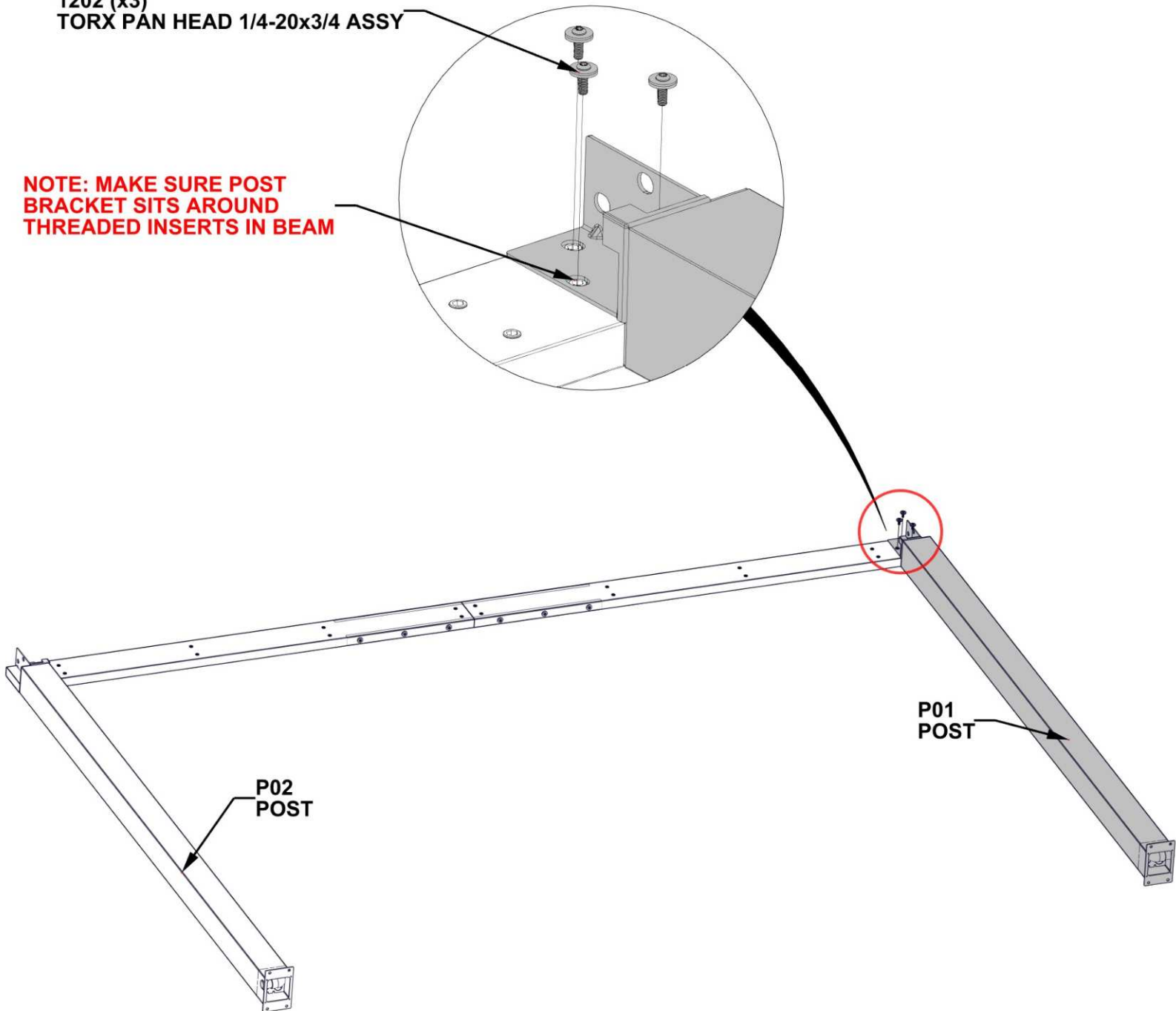

STEP 5 - LOUVER MOUNT ATTACHMENT

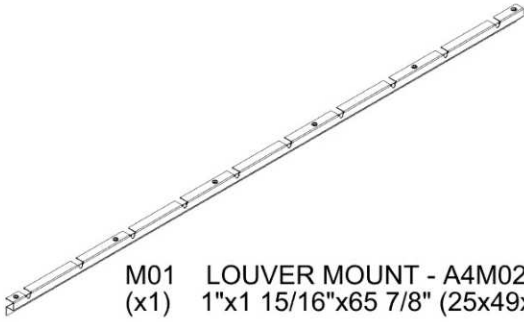

M01 LOUVER MOUNT - A4M02864
(x1) 1"x1 15/16"x65 7/8" (25x49x1673)

QTY	PART NUMBER	DESCRIPTION
4	H101202	TORX PAN HEAD 1/4-20x3/4 ASSY

NOTE: FLUSH MOUNT WITH EDGE OF POST BRACKET

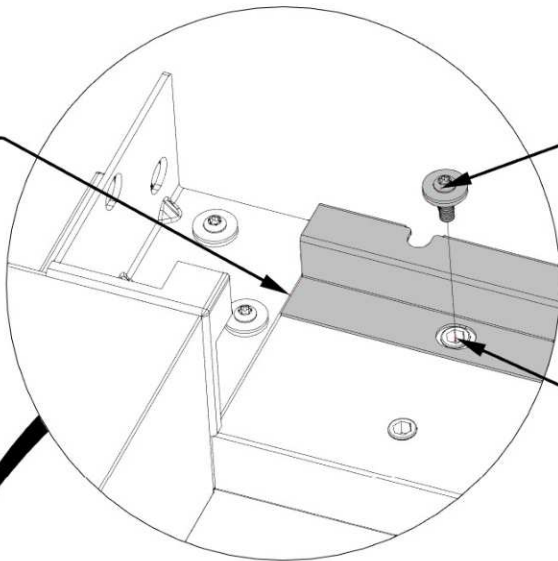

1202 (x4)
TORX PAN HEAD 1/4-20x3/4 ASSY

NOTE: LOUVER MOUNT WILL FIT AROUND THREADED INSERTS IN BEAM

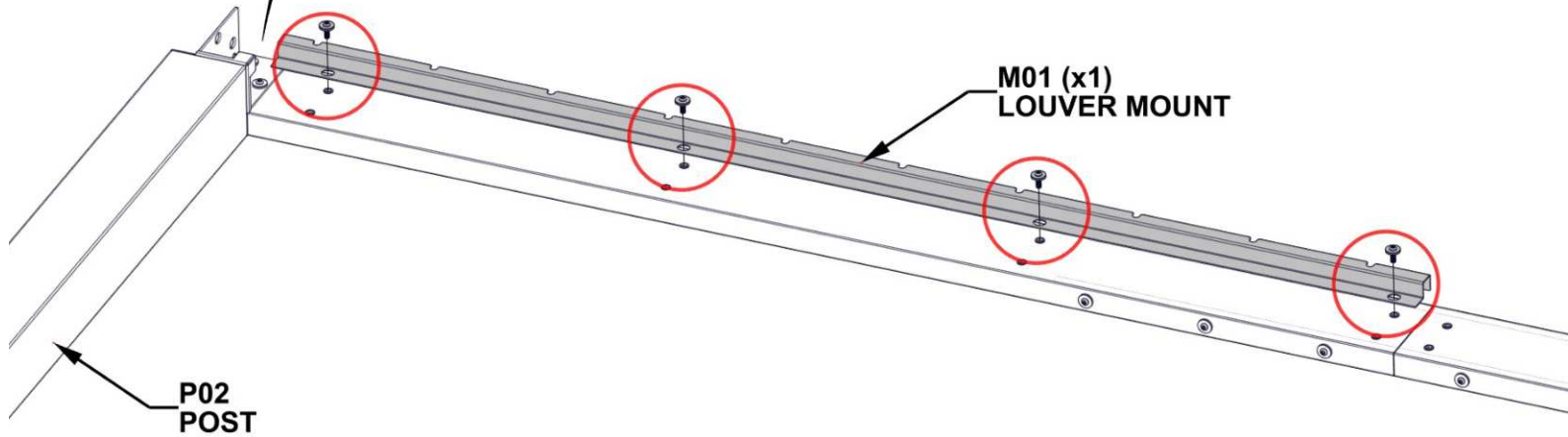

STEP 6 - LOUVER MOUNT ATTACHMENT



QTY	PART NUMBER	DESCRIPTION
4	H101202	TORX PAN HEAD 1/4-20x3/4 ASSY

M03 LOUVER MOUNT - A4M02866
 (x1) 1"x1 15/16"x65 7/8" (25x49x1673)

1202 (x4)
 TORX PAN HEAD 1/4-20x3/4 ASSY

NOTE: LOUVER MOUNT WILL FIT AROUND THREADED INSERTS IN BEAM

NOTE: FLUSH MOUNT WITH EDGE OF POST BRACKET

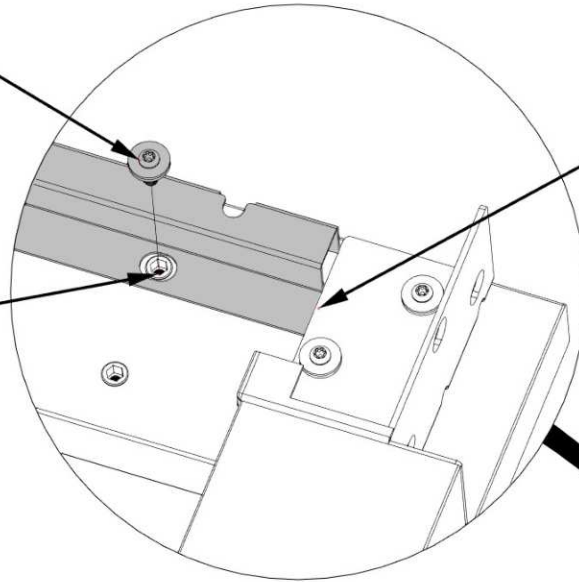

M03 (x1)
 LOUVER MOUNT

NOTE: THERE WILL BE A SMALL GAP BETWEEN EACH LOUVER MOUNT

P01
 POST

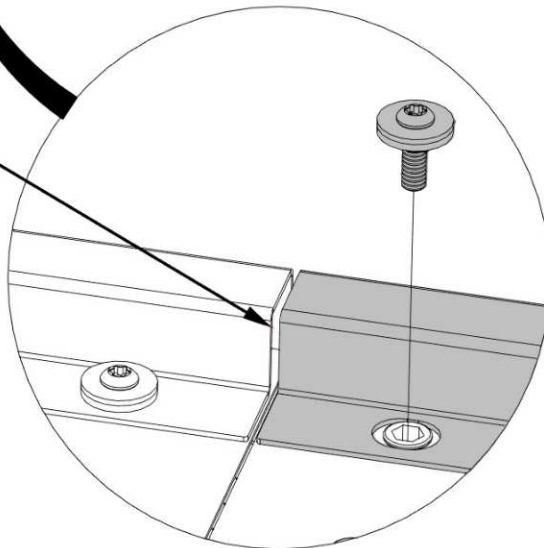

STEP 7A - GUTTER ASSEMBLY

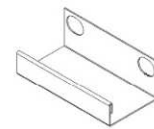
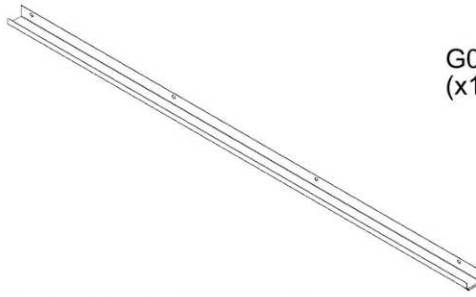
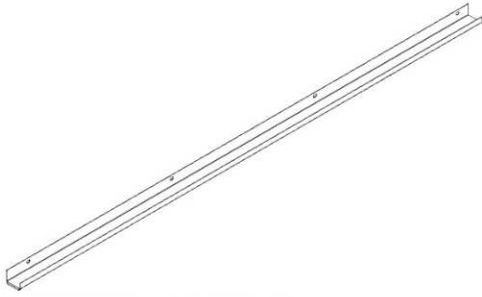

G05 GUTTER SPLICE - A4M02004
(x1) 1 7/16"x2 1/16"x3 15/16" (36x52.5x100)



A6P00796 SILICONE
(x1)

G03 GUTTER - A4M02857
(x1) 1 9/16"x1 15/16"x65 15/16" (40x50x1675)

G04 GUTTER - A4M02858
(x1) 1 9/16"x1 15/16"x65 15/16" (40x50x1675)

- MEASURE APPROXIMATELY 1/2" [12.7mm] FROM EACH END OF GUTTER SPLICE AND APPLY A FINE BEAD OF SILICONE.
- SLIDE BOTH G03 AND G04 GUTTERS INTO SPLICE UNTIL ENDS ARE ALMOST TOUCHING. WIPE EXCESS SILICONE USING A RAG OR PAPER TOWEL.
- GLOVES ARE RECOMMENDED WHEN APPLYING SILICONE
- MAKE SURE SURFACE OF GUTTER SPLICE IS CLEAN, DRY, AND FREE OF ANY DIRT/DEBRIS

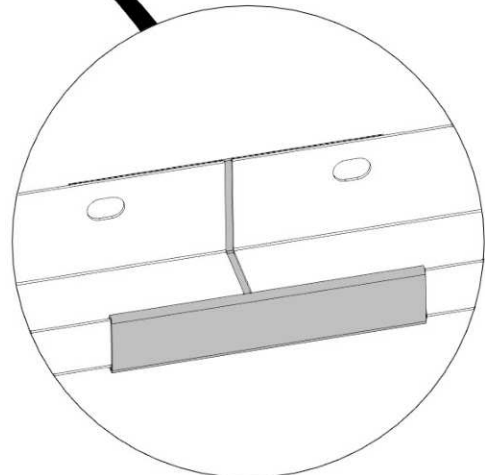
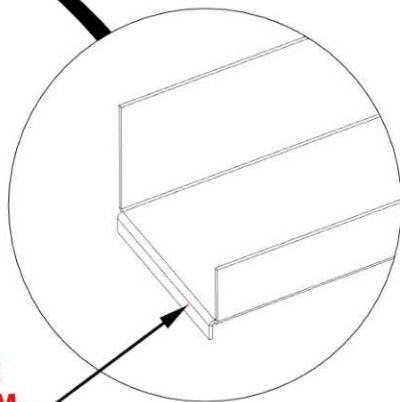
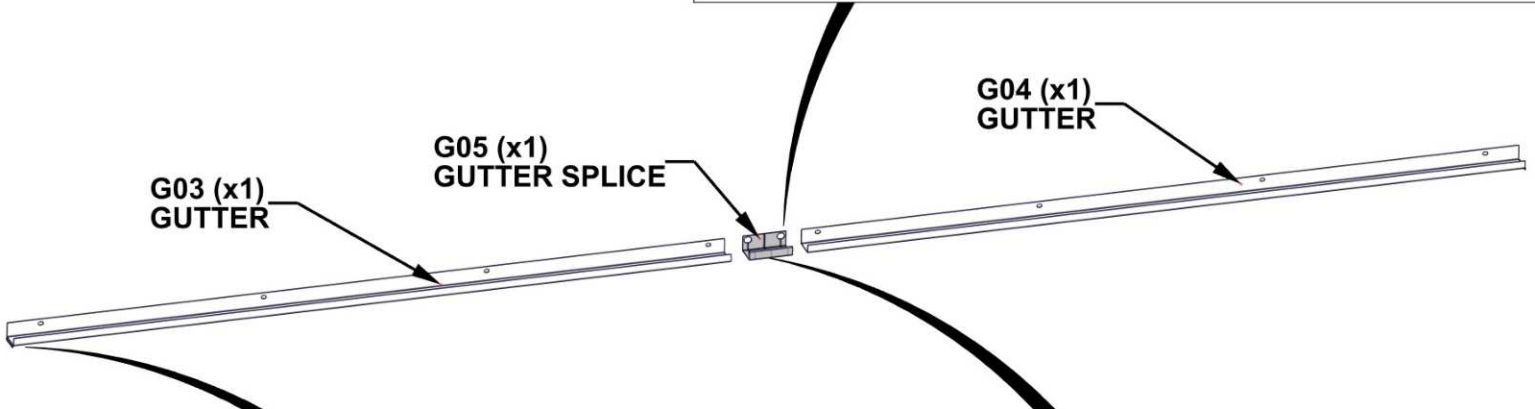
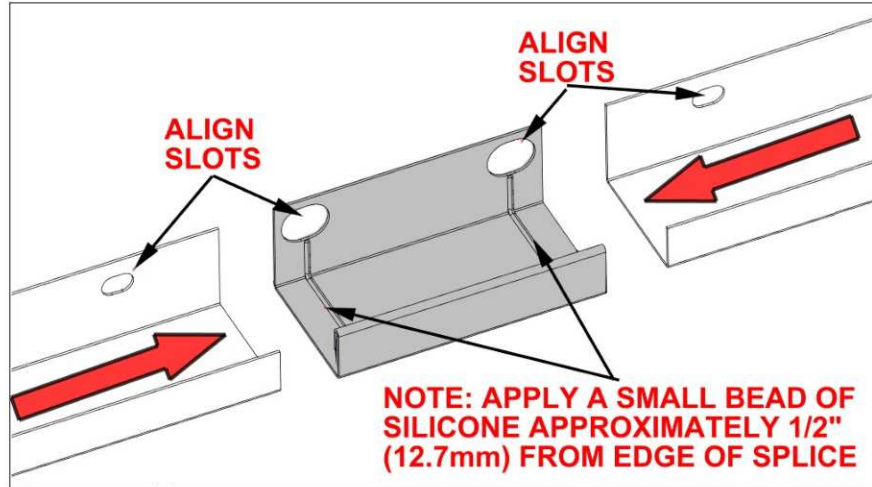

NOTE: GUTTER ENDS WILL HAVE A BOTTOM FLANGE

STEP 7B - GUTTER ATTACHMENT

QTY	PART NUMBER	DESCRIPTION
8	H101202	TORX PAN HEAD 1/4-20x3/4 ASSY

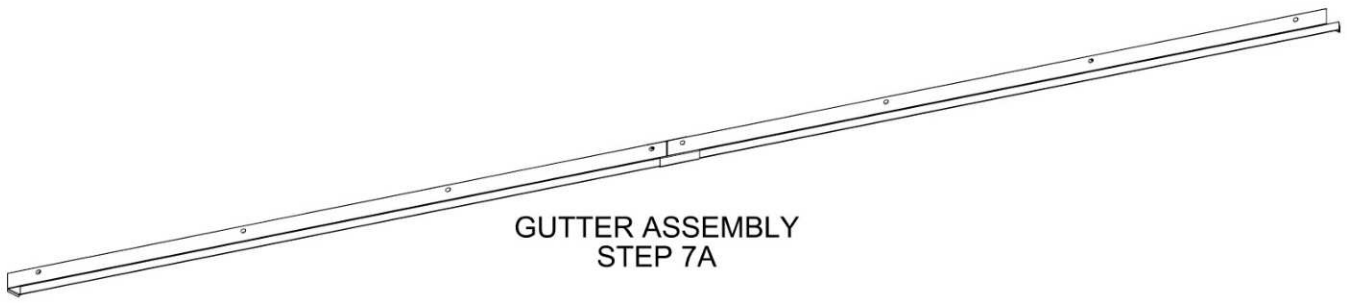

- WITH AT LEAST TWO PEOPLE ATTACH GUTTER ASSEMBLY FROM PREVIOUS STEP TO BEAM.
- MAKE SURE ENDS OF GUTTER SIT ON TOP SURFACE OF EACH POST BRACKET.

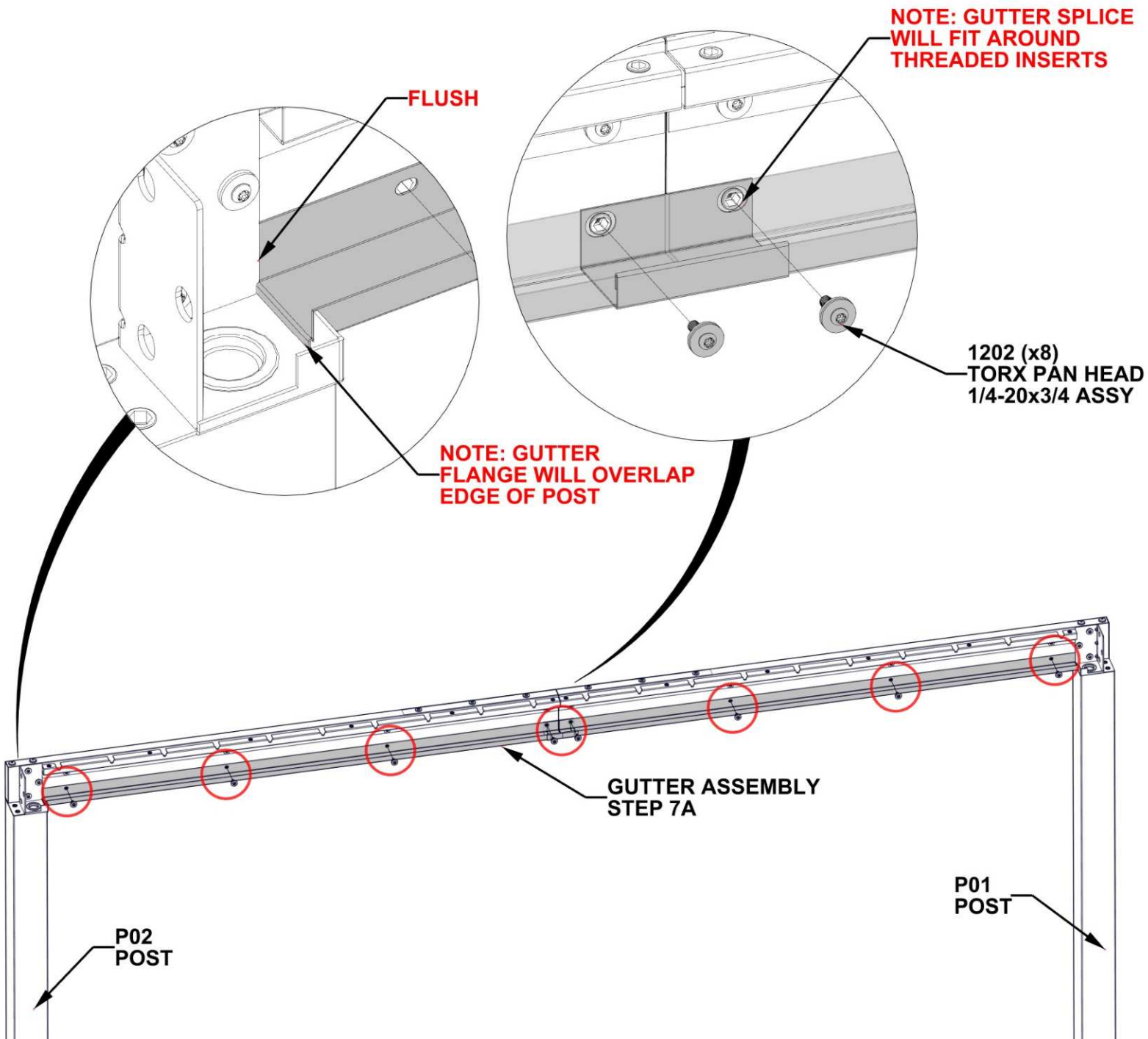

STEP 7C - GUTTER ATTACHMENT



A6P00796 SILICONE
(x1)

- APPLY A FINE BEAD OF SILICONE ALONG INSIDE SURFACE OF GUTTER WHERE TWO GUTTER PIECES MEET.
- SMOOTH SILICONE ALONG SEAM, WIPING EXCESS USING A RAG OR PAPER TOWEL
- GLOVES ARE RECOMMENDED WHEN APPLYING SILICONE.
- MAKE SURE SURFACE OF GUTTER IS CLEAN, DRY, AND FREE OF ANY DIRT/DEBRIS

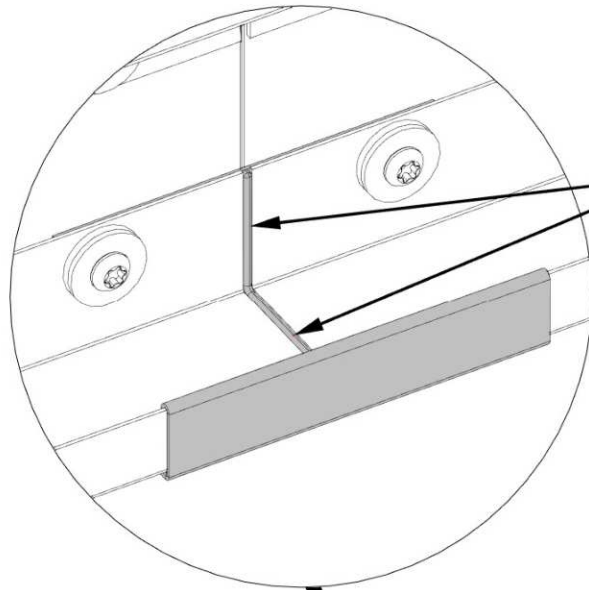

NOTE: APPLY A FINE BEAD OF SILICONE ALONG INSIDE SEAM OF GUTTER

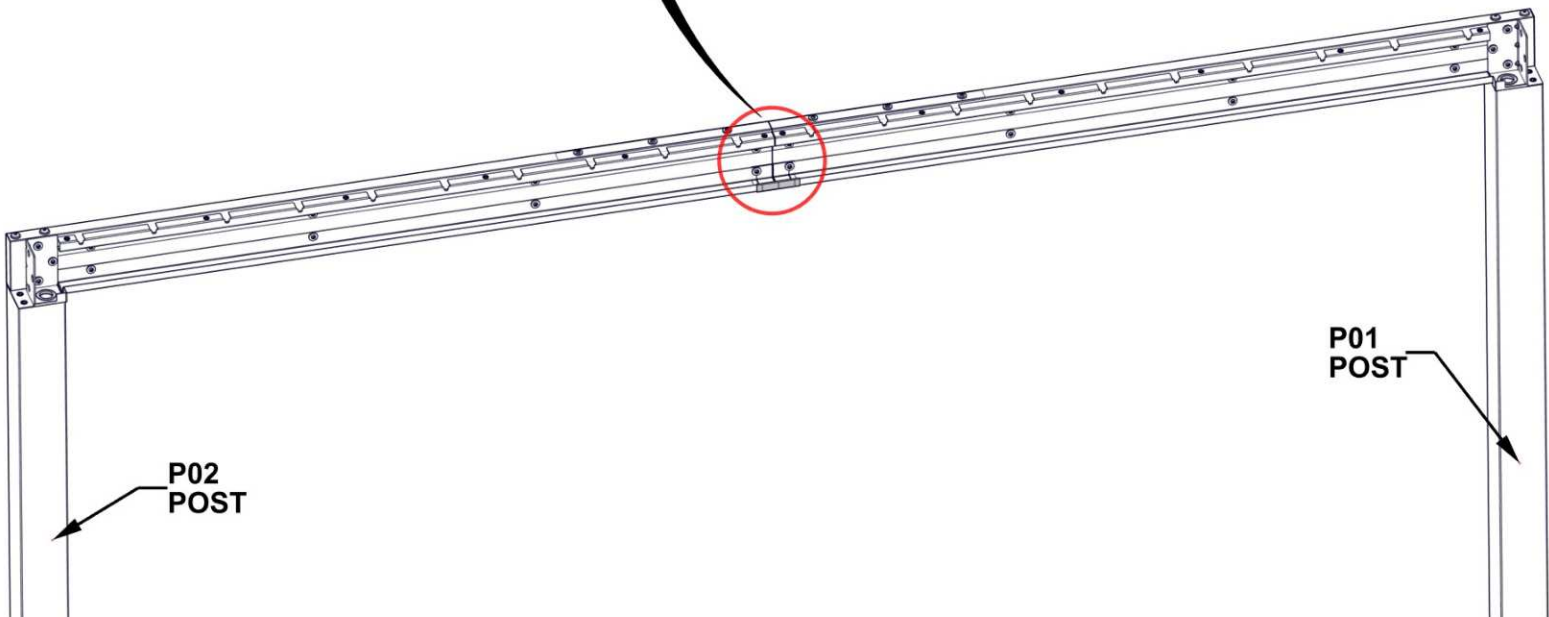

STEP 8A - FRAME ASSEMBLY

QTY	PART NUMBER	DESCRIPTION
4	H101230	BOLT WH 5/16x6 S.S.

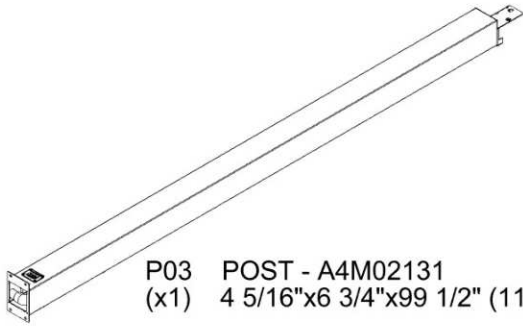

P03 POST - A4M02131
(x1) 4 5/16"x6 3/4"x99 1/2" (110x172x2527)



B01 BEAM - A4M01986
(x1) 1 7/16"x5 1/4"x114 1/2" (36x134x2910)

- WITH AT LEAST TWO EXTRA PEOPLE, ATTACH B01 BEAM TO P02 AND P03 POST.
- ALIGN SLOTS IN BEAM WITH THREADED INSERTS ON TOP PLATE. FLUSH ALL SIDES OF BEAM AND POST.

NOTE: LARGE SLOTS INDICATE BOTTOM SURFACE OF BEAM. SLOTS WILL FIT AROUND THREADED INSERTS IN POST PLATE.

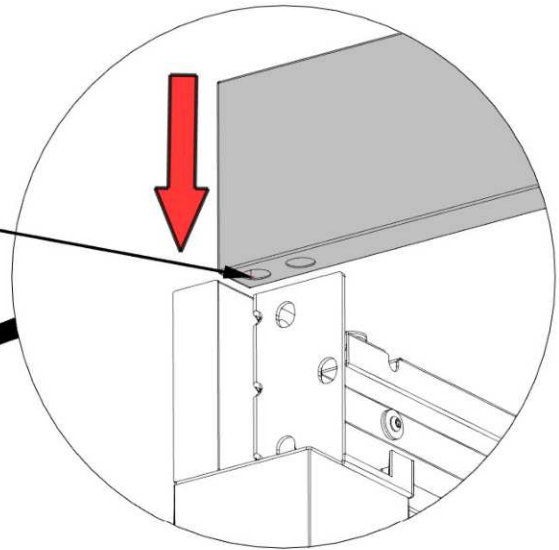

BACK VIEW

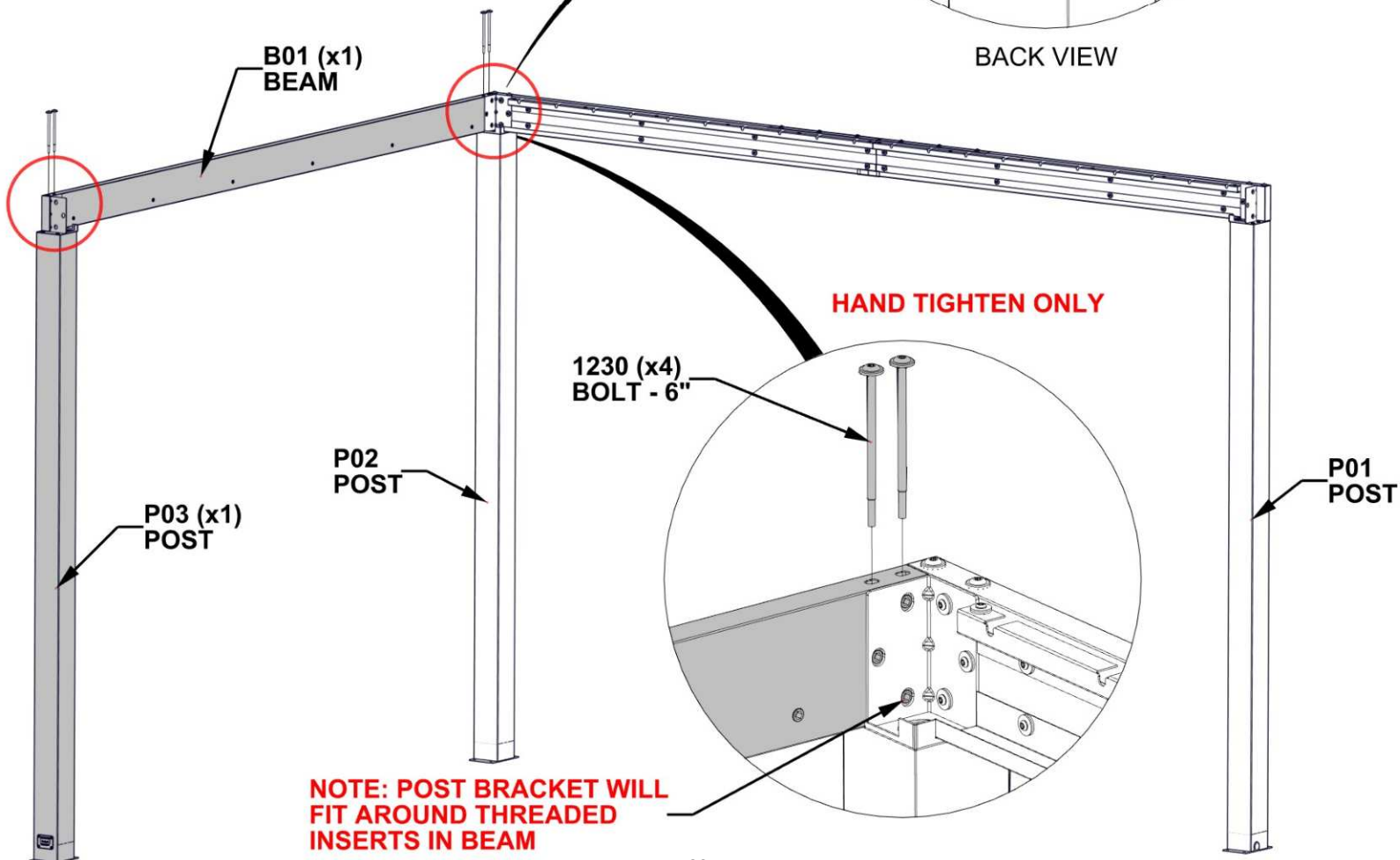

HAND TIGHTEN ONLY

NOTE: POST BRACKET WILL FIT AROUND THREADED INSERTS IN BEAM

STEP 8B - FRAME ASSEMBLY

QTY	PART NUMBER	DESCRIPTION
6	H101202	TORX PAN HEAD 1/4-20x3/4 ASSY

NOTE: MAKE SURE POST BRACKET SITS AROUND THREADED INSERTS IN BEAM

**1202 (x6)
TORX PAN HEAD 1/4-20x3/4 ASSY**

HAND TIGHTEN ONLY

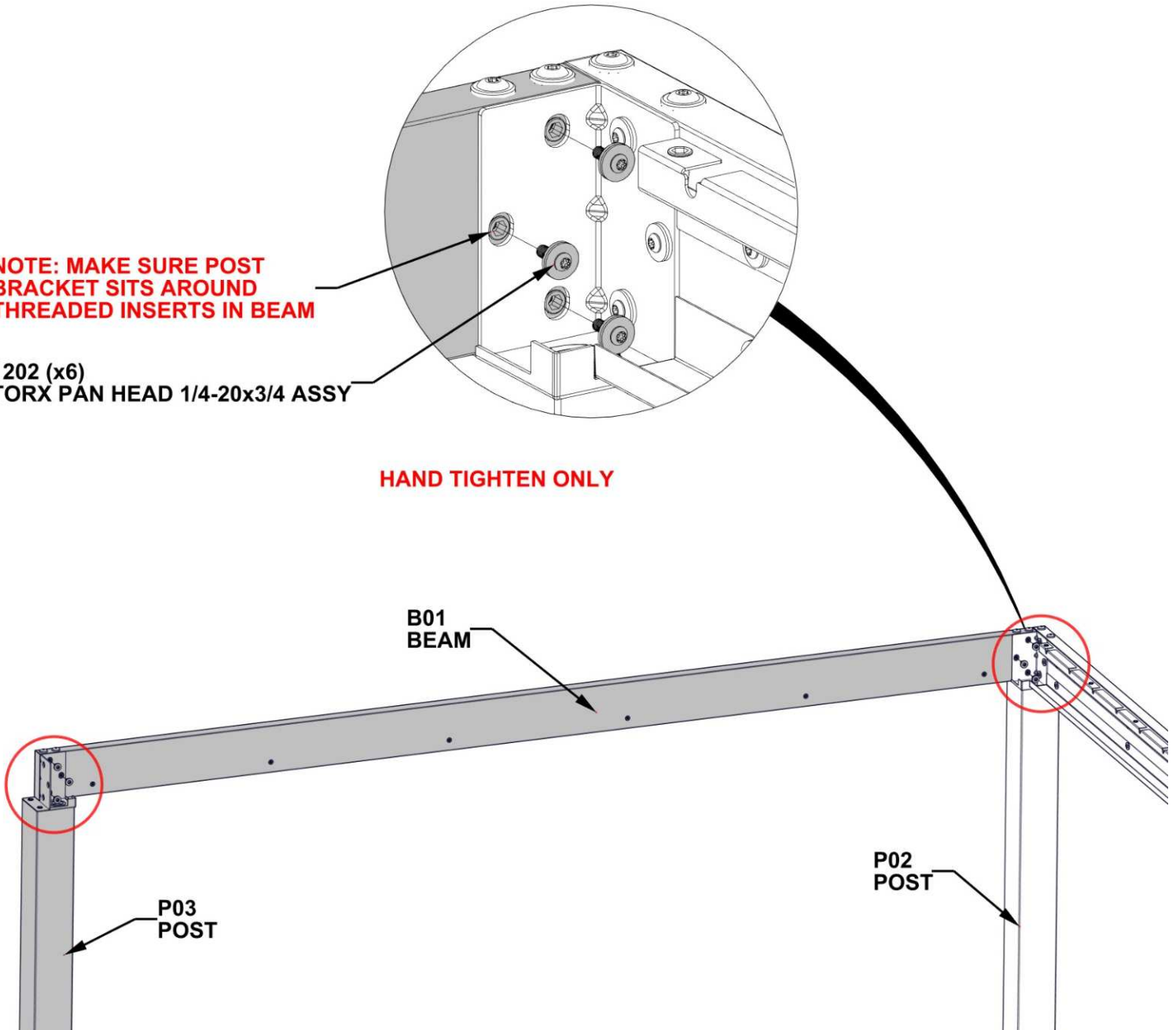

STEP 9 - GUTTER ATTACHMENT

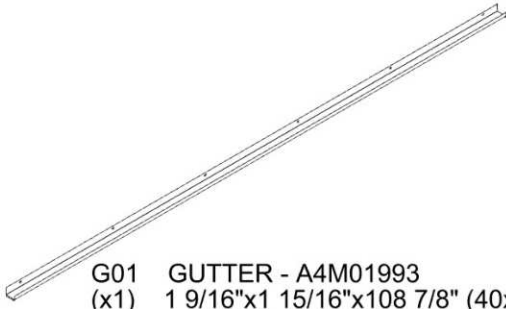

G01 GUTTER - A4M01993
(x1) 1 9/16"x1 15/16"x108 7/8" (40x50x2765)

QTY	PART NUMBER	DESCRIPTION
6	H101202	TORX PAN HEAD 1/4-20x3/4 ASSY

- WITH AN ADDITIONAL PERSON, ATTACH GUTTER TO BEAM.
- MAKE SURE ENDS OF GUTTER SIT ON TOP SURFACE OF EACH POST BRACKET.

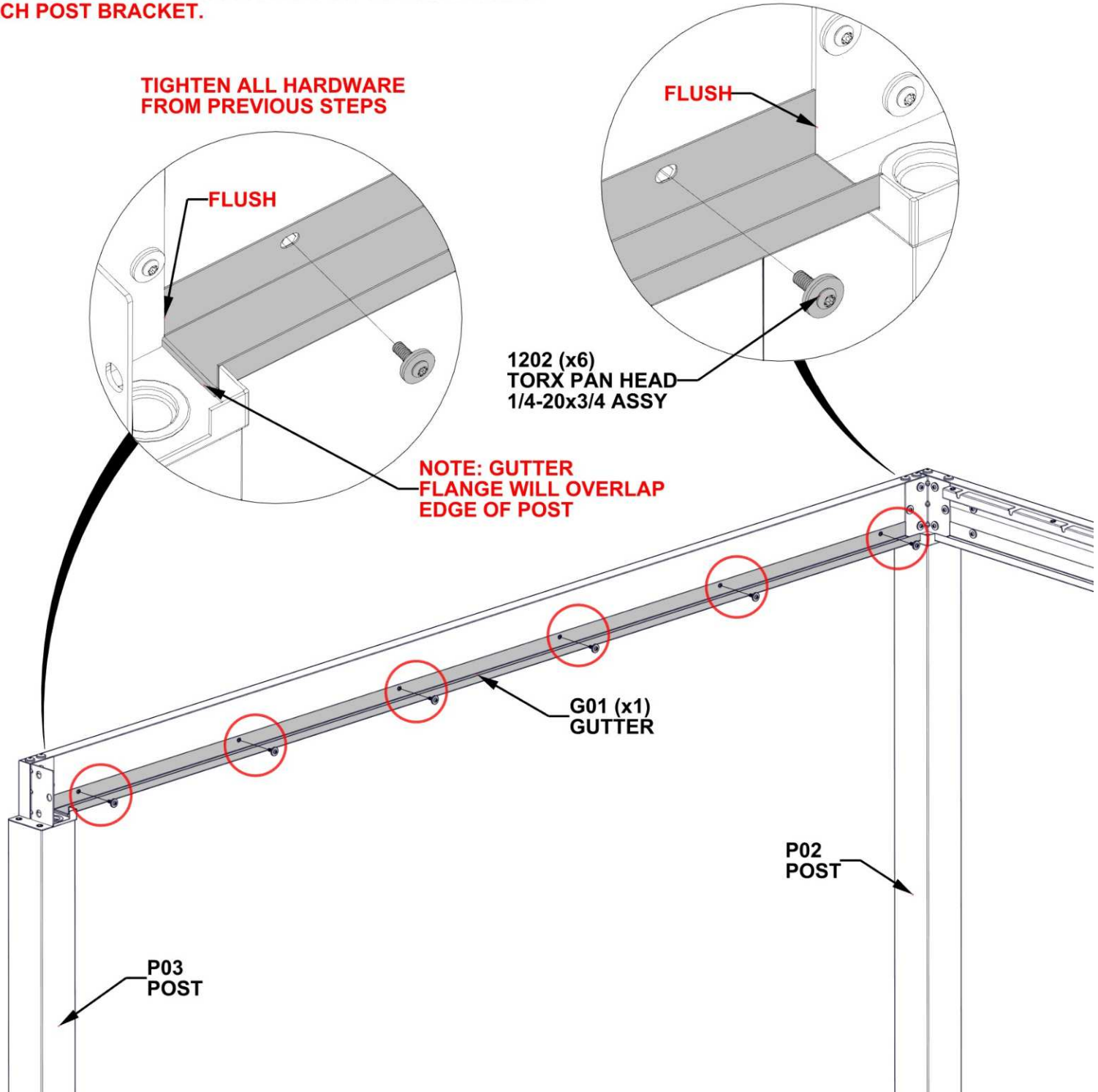

STEP 10A - FRAME ASSEMBLY

QTY	PART NUMBER	DESCRIPTION
4	H101230	BOLT WH 5/16x6 S.S.

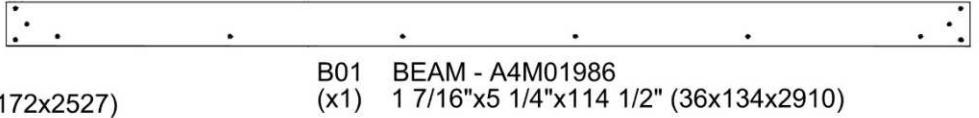
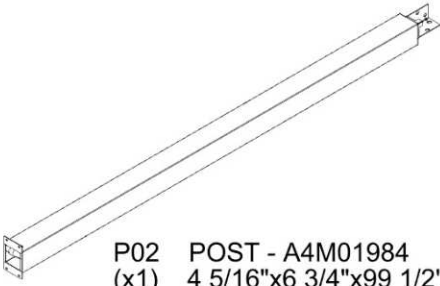

- WITH AT LEAST TWO EXTRA PEOPLE, ATTACH B01 BEAM TO P02 AND P01 POST.
- ALIGN SLOTS IN BEAM WITH THREADED INSERTS ON TOP PLATE. FLUSH ALL SIDES OF BEAM AND POST.

NOTE: LARGE SLOTS INDICATE BOTTOM SURFACE OF BEAM. SLOTS WILL FIT AROUND THREADED INSERTS IN POST PLATE.

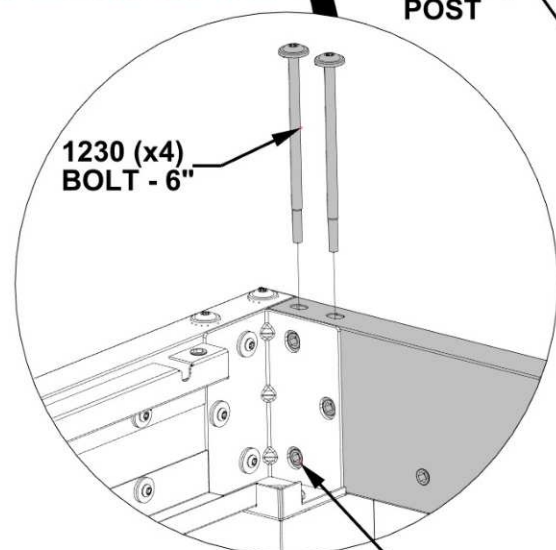
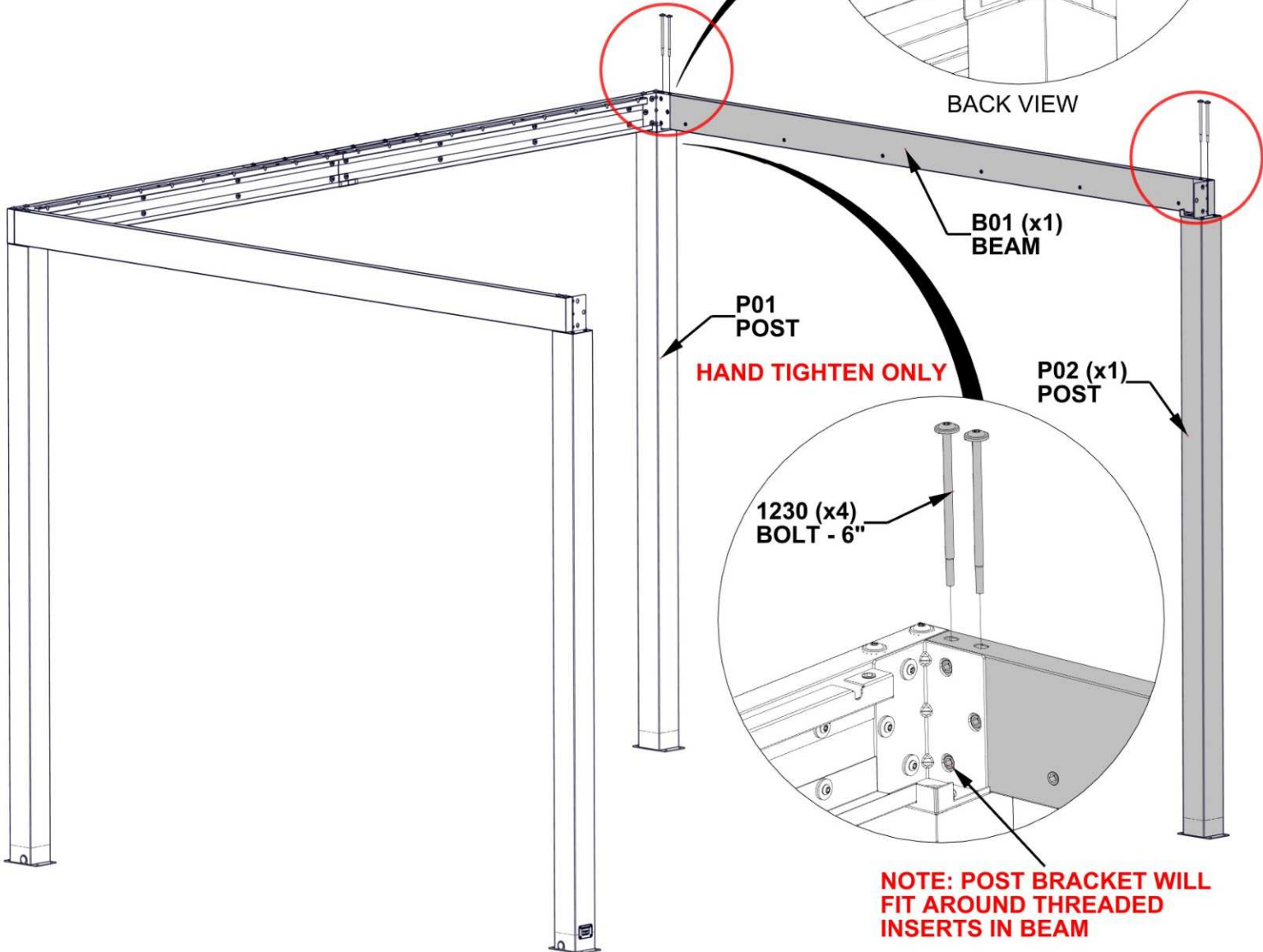
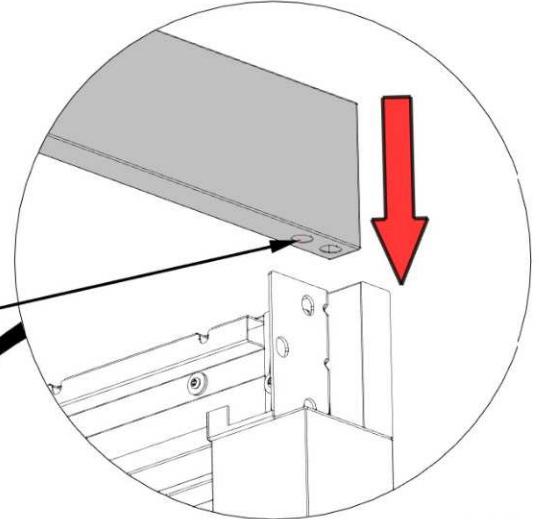

NOTE: POST BRACKET WILL FIT AROUND THREADED INSERTS IN BEAM

STEP 10B - FRAME ASSEMBLY

QTY	PART NUMBER	DESCRIPTION
6	H101202	TORX PAN HEAD 1/4-20x3/4 ASSY

NOTE: MAKE SURE POST BRACKET SITS AROUND THREADED INSERTS IN BEAM.

**1202 (x6)
TORX PAN HEAD 1/4-20x3/4 ASSY**

HAND TIGHTEN ONLY

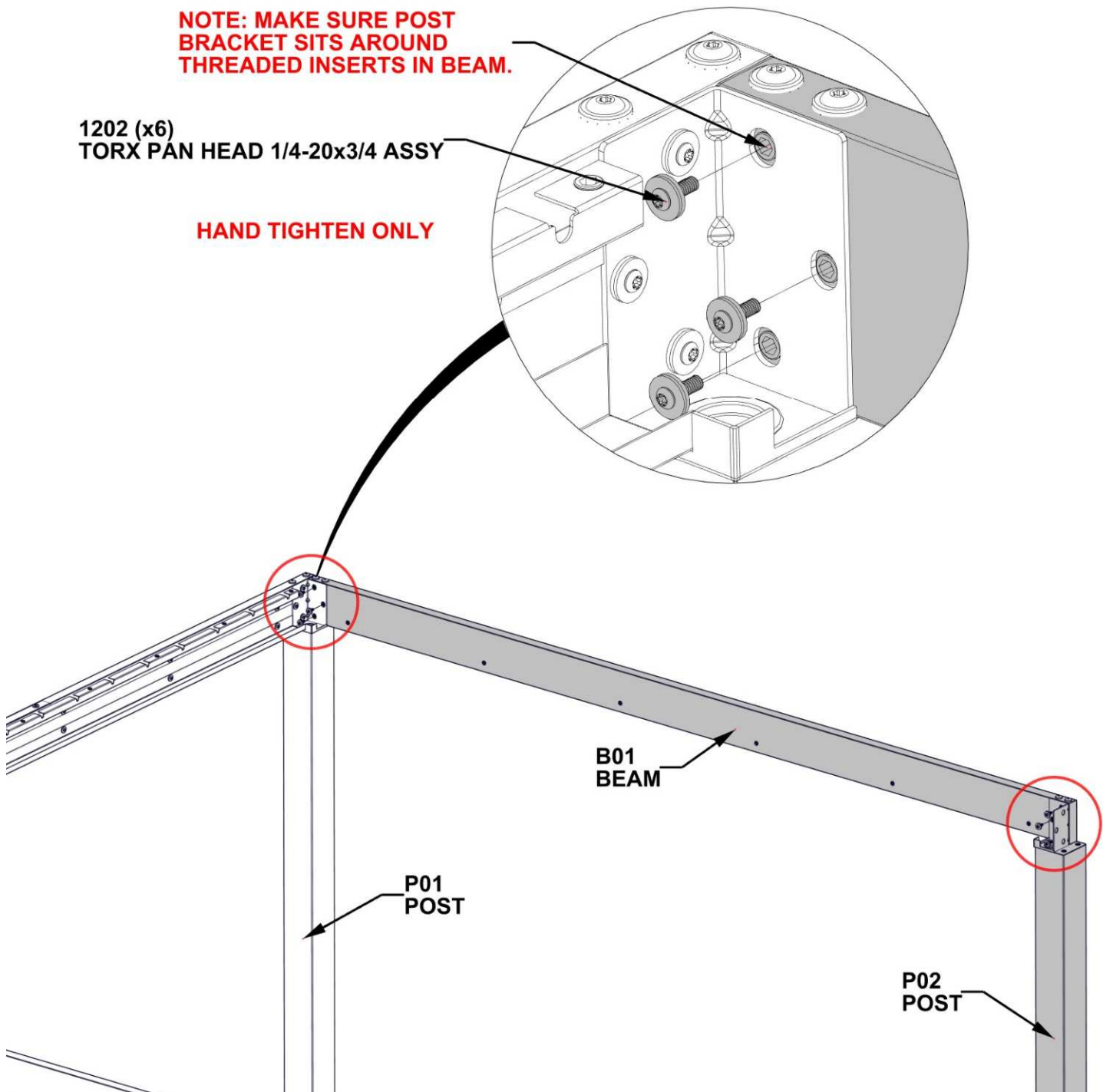

STEP 11 - GUTTER ATTACHMENT

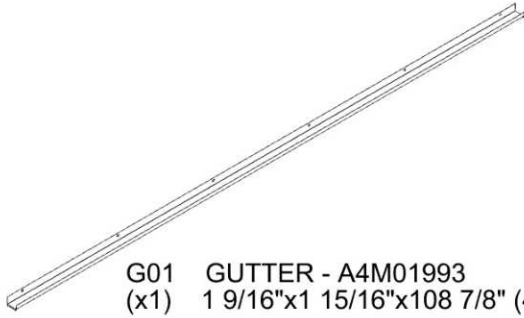

G01 GUTTER - A4M01993
 (x1) 1 9/16"x1 15/16"x108 7/8" (40x50x2765)

QTY	PART NUMBER	DESCRIPTION
6	H101202	TORX PAN HEAD 1/4-20x3/4 ASSY

- WITH AN ADDITIONAL PERSON, ATTACH GUTTER TO BEAM.
- MAKE SURE ENDS OF GUTTER SIT ON TOP SURFACE OF EACH POST BRACKET.

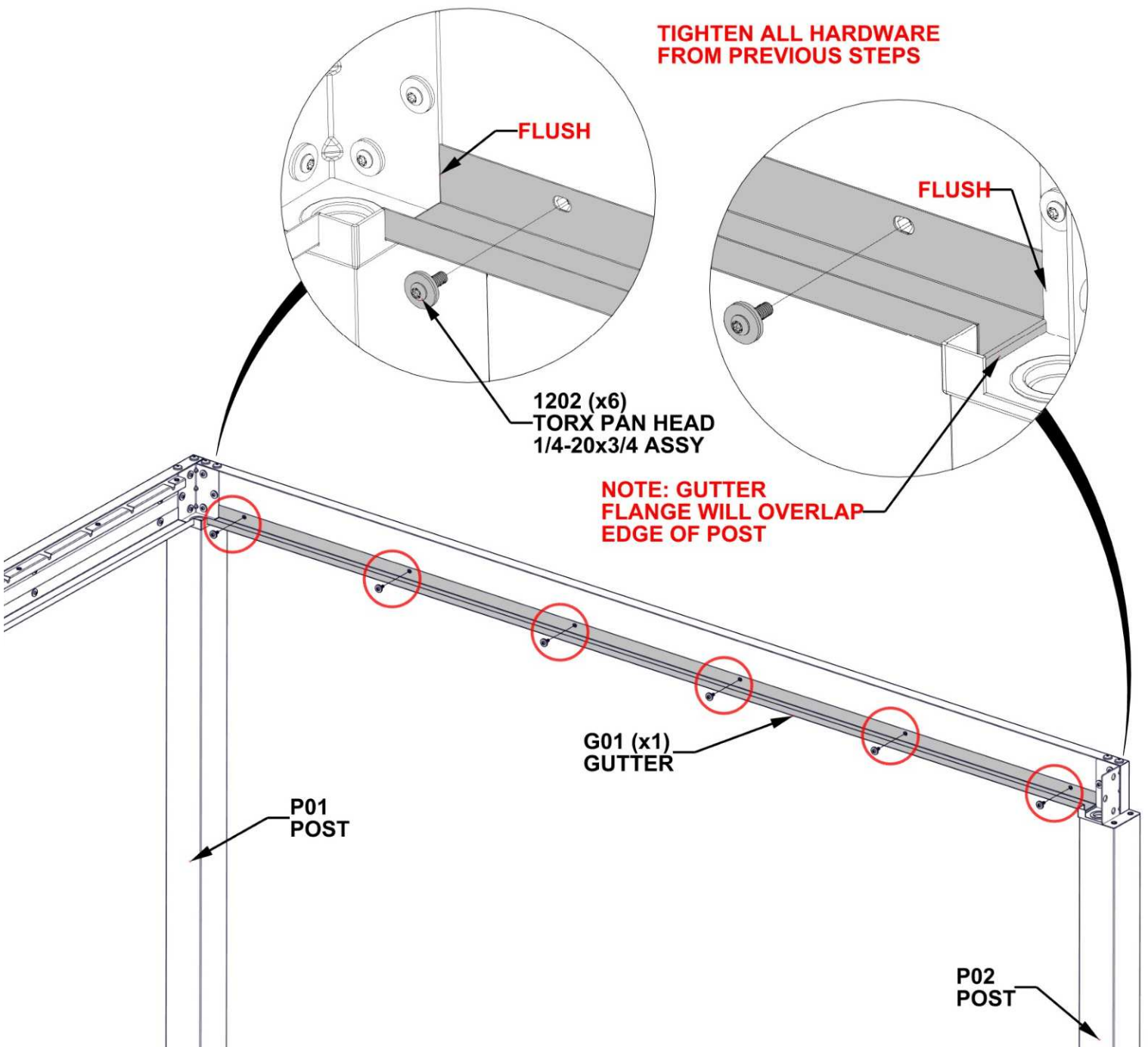

STEP 12 - BEAM ASSEMBLY

QTY	PART NUMBER	DESCRIPTION
6	H101202	TORX PAN HEAD 1/4-20x3/4 ASSY



B03 BEAM - A4M02862
(x1) 1 7/16"x5 1/4"x70 1/4" (36x134x1784)



J1 SPLICE BRACKET - A4M02230
(x1) 1 5/16"x5 3/16"x39 3/8" (33.2x131.2x1000)

- BEAM AND SPLICE MUST BE ORIENTED AS SHOWN BELOW. SLIDE J1 INTO B03 AND LINE UP THREE HOLES TOP AND BOTTOM.

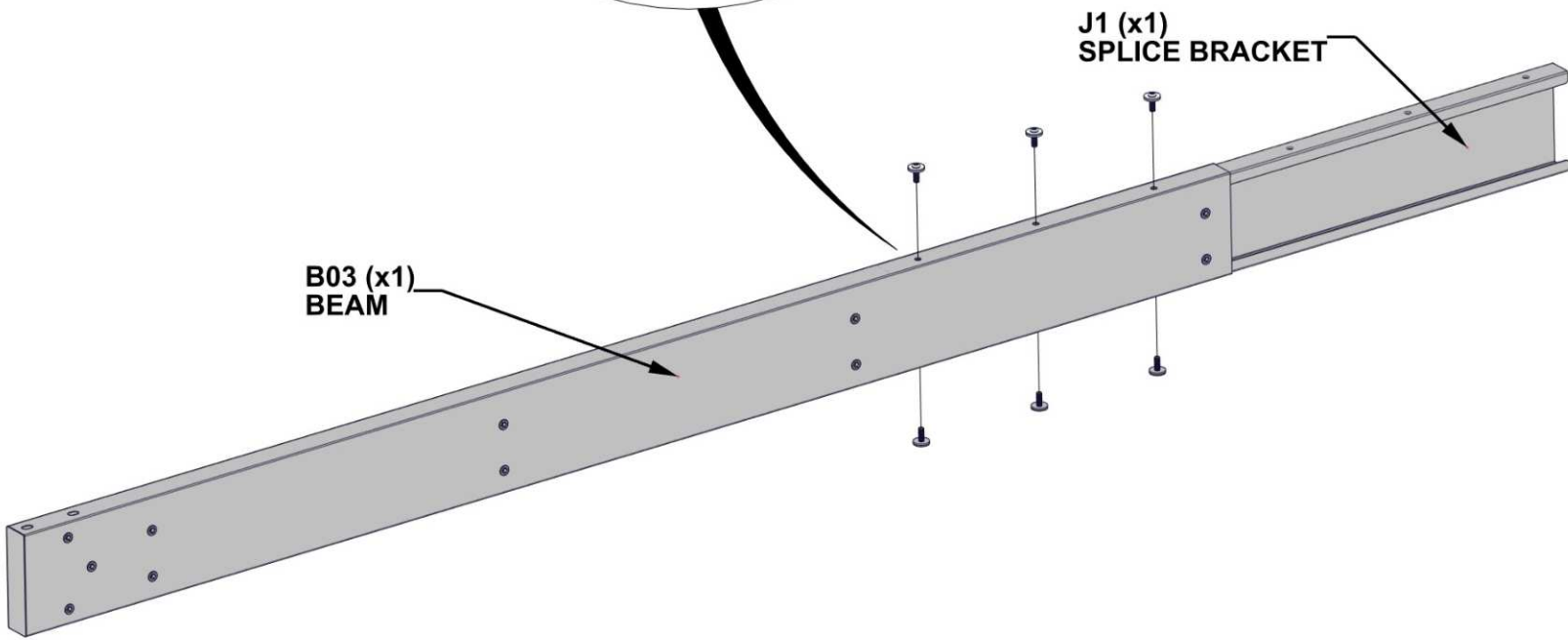
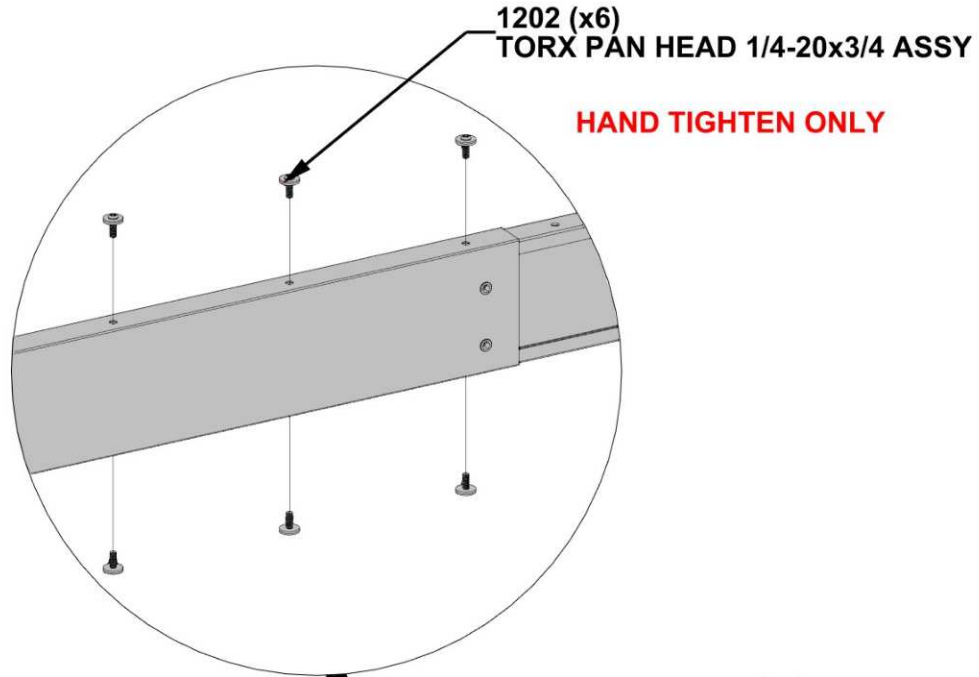

STEP 13 - BEAM ASSEMBLY

QTY	PART NUMBER	DESCRIPTION
6	H101202	TORX PAN HEAD 1/4-20x3/4 ASSY



B04 BEAM - A4M02863
(x1) 1 7/16"x5 1/4"x70 1/4" (36x134x1784)

**- SLIDE B04 INTO SPLICE BRACKET.
GENTLY TAP ENDS OF ASSEMBLY
WITH RUBBER Mallet UNTIL GAP
CLOSES, THEN TIGHTEN ALL BOLTS
ON BEAM.**

1202 (x6)
TORX PAN HEAD 1/4-20x3/4 ASSY

TIGHTEN ALL HARDWARE

**NOTE: THREADED INSERT
ORIENTATION ON SIDE
OF BEAM**

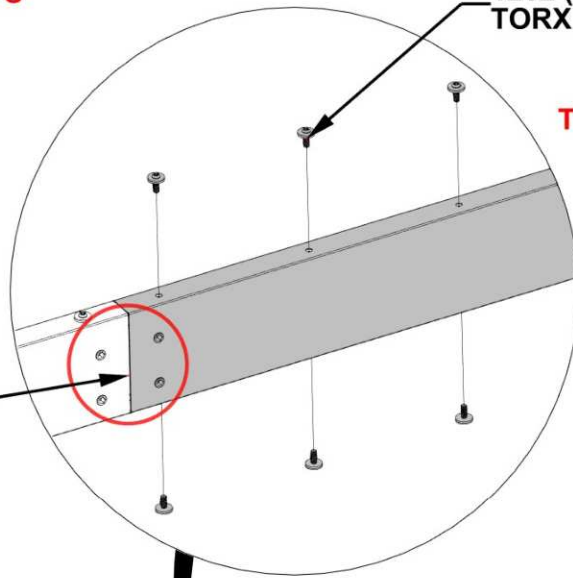

B04 (x1)
BEAM

STEP 14A - FRAME ASSEMBLY

QTY	PART NUMBER	DESCRIPTION
4	H101230	BOLT WH 5/16x6 S.S.

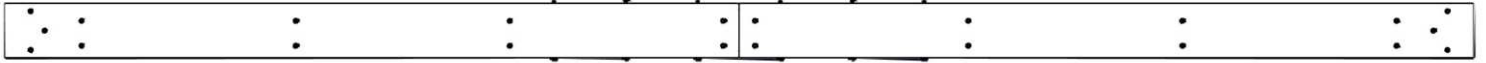

BEAM ASSEMBLY
STEP 12 - 13

- WITH AT LEAST TWO EXTRA PEOPLE, ATTACH BEAM ASSEMBLY FROM PREVIOUS STEPS TO P02 AND P03 POST.
- ALIGN SLOTS IN BEAM WITH THREADED INSERTS ON TOP PLATE. FLUSH ALL SIDES OF BEAM AND POST.

HAND TIGHTEN ONLY

1230 (x4)
BOLT - 6"

NOTE: LARGE SLOTS INDICATE
BOTTOM SURFACE OF BEAM.
SLOTS WILL FIT AROUND THREADED
INSERTS IN POST PLATE.

FLUSH

NOTE: POST BRACKET WILL
FIT AROUND THREADED
INSERTS IN BEAM

BACK VIEW

BEAM ASSEMBLY
STEP 12 - 13

P02
POST

P03
POST

STEP 14B - FRAME ASSEMBLY

QTY	PART NUMBER	DESCRIPTION
6	H101202	TORX PAN HEAD 1/4-20x3/4 ASSY

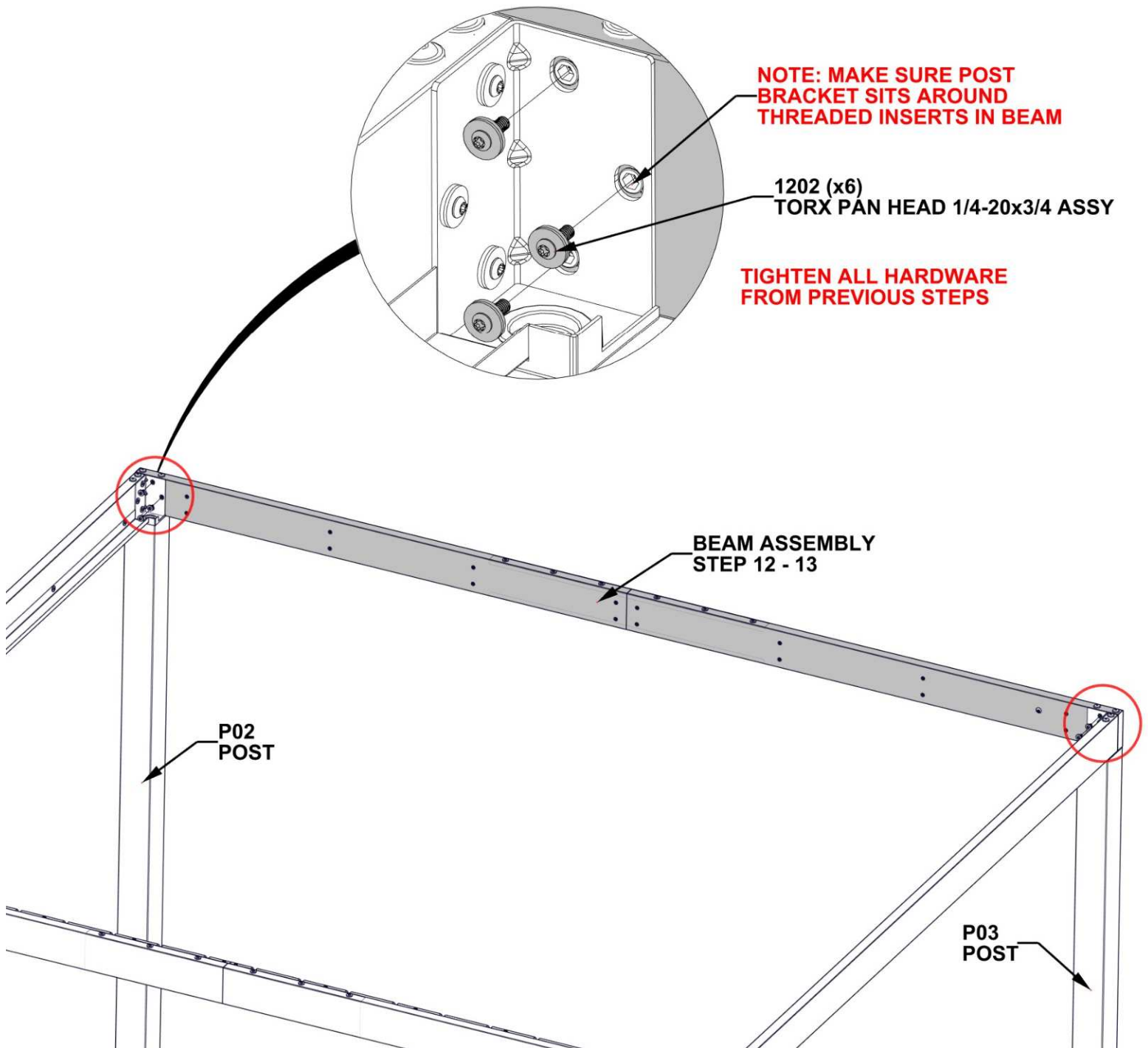

STEP 15 - LOUVER MOUNT ATTACHMENT

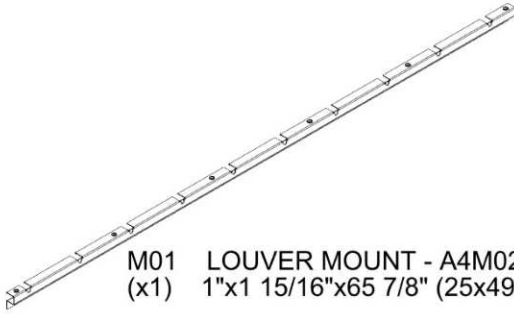

M01 LOUVER MOUNT - A4M02864
(x1) 1"x1 15/16"x65 7/8" (25x49x1673)

QTY	PART NUMBER	DESCRIPTION
4	H101202	TORX PAN HEAD 1/4-20x3/4 ASSY

NOTE: FLUSH MOUNT WITH EDGE OF POST BRACKET

NOTE: LOUVER MOUNT WILL FIT AROUND THREADED INSERTS IN BEAM

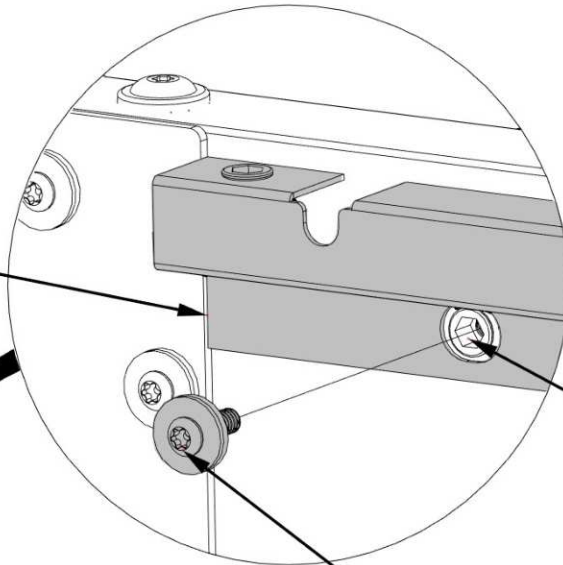

1202 (x4)
TORX PAN HEAD 1/4-20x3/4 ASSY

M01 (x1)
LOUVER MOUNT

P02
POST

STEP 16 - LOUVER MOUNT ATTACHMENT

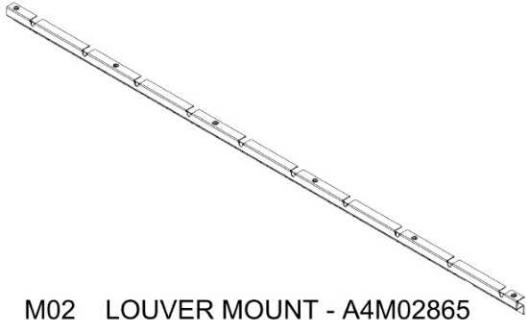

QTY	PART NUMBER	DESCRIPTION
4	H101202	TORX PAN HEAD 1/4-20x3/4 ASSY

M02 LOUVER MOUNT - A4M02865
 (x1) 1"x1 15/16"x65 7/8" (25x49x1673)

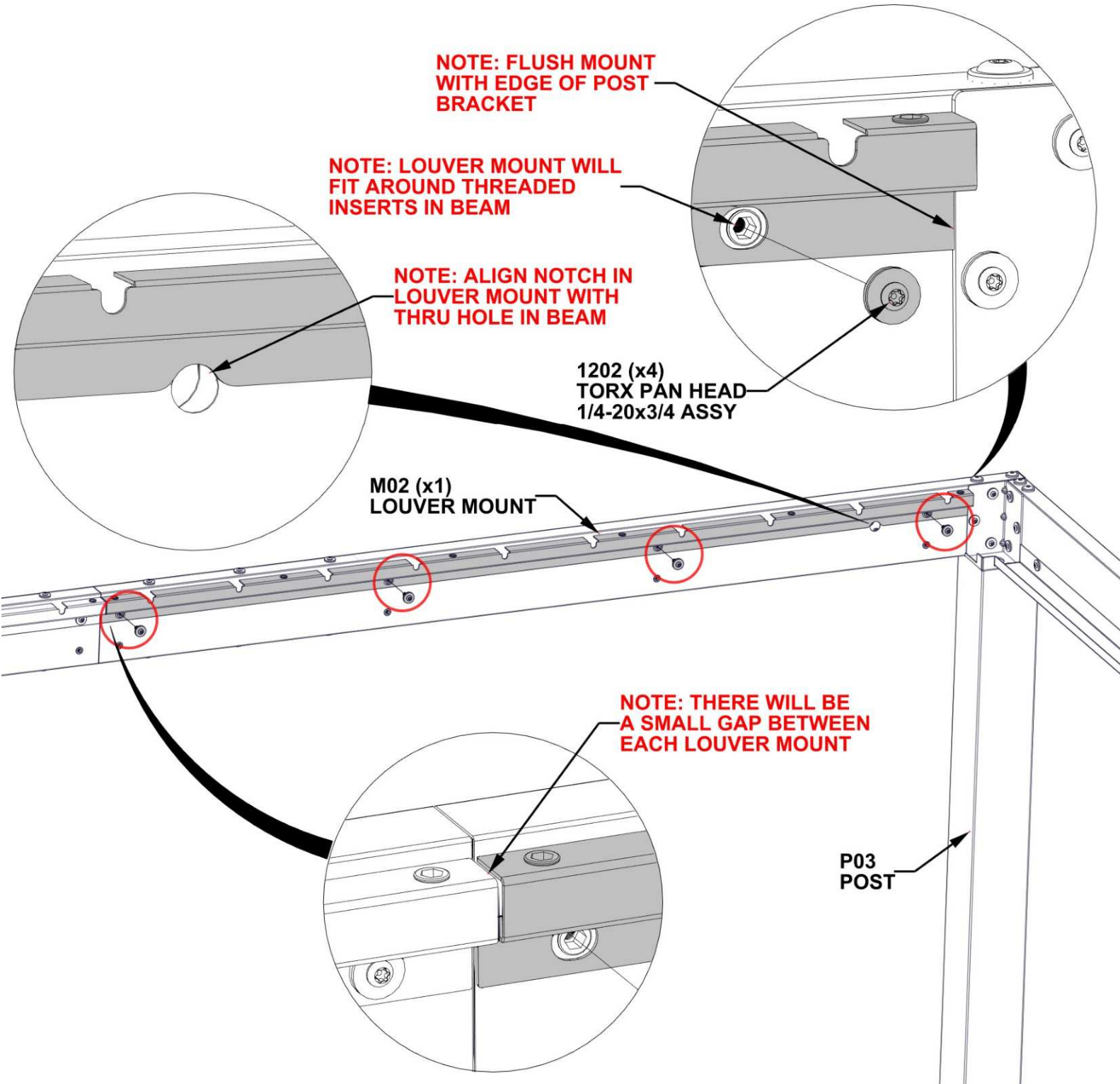

STEP 17A - GUTTER ASSEMBLY

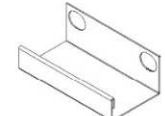
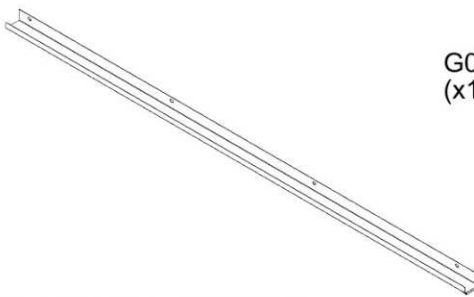
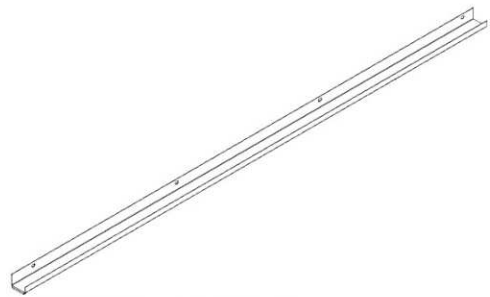

G05 GUTTER SPLICE - A4M02004
(x1) 1 7/16"x2 1/16"x3 15/16" (36x52.5x100)



A6P00796 SILICONE
(x1)

G03 GUTTER - A4M02857
(x1) 1 9/16"x1 15/16"x65 15/16" (40x50x1675)

G04 GUTTER - A4M02858
(x1) 1 9/16"x1 15/16"x65 15/16" (40x50x1675)

- MEASURE APPROXIMATELY 1/2" [12.7mm] FROM EACH END OF GUTTER SPLICE AND APPLY A FINE BEAD OF SILICONE.

- SLIDE BOTH G03 AND G04 GUTTERS INTO SPLICE UNTIL ENDS ARE ALMOST TOUCHING. WIPE EXCESS SILICONE USING A RAG OR PAPER TOWEL.

- GLOVES ARE RECOMMENDED WHEN APPLYING SILICONE

- MAKE SURE SURFACE OF GUTTER SPLICE IS CLEAN, DRY, AND FREE OF ANY DIRT/DEBRIS

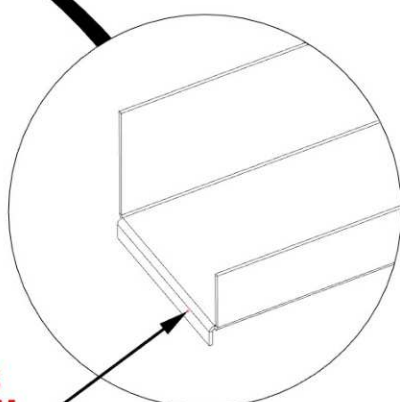
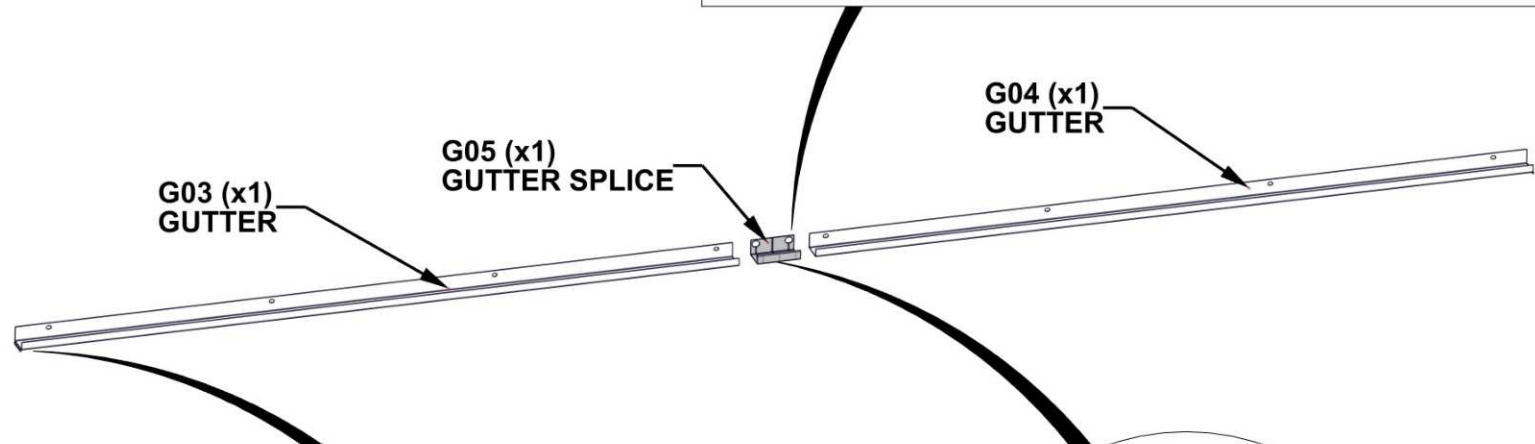
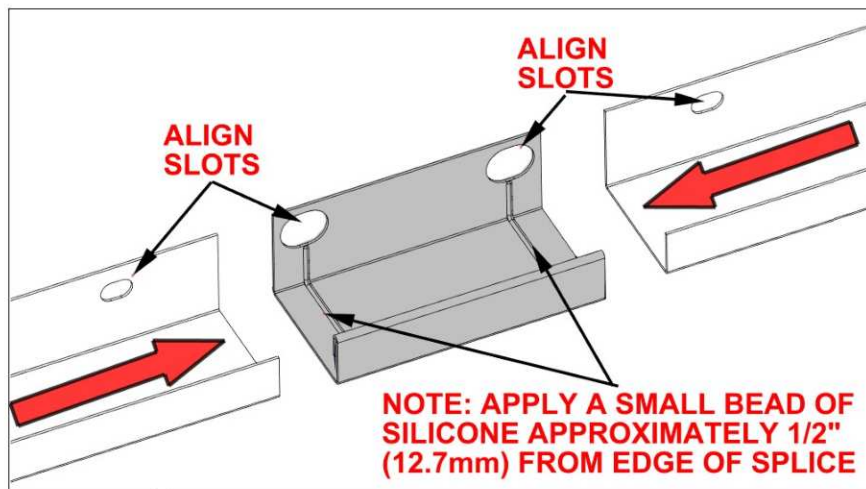

NOTE: GUTTER ENDS WILL HAVE A BOTTOM FLANGE

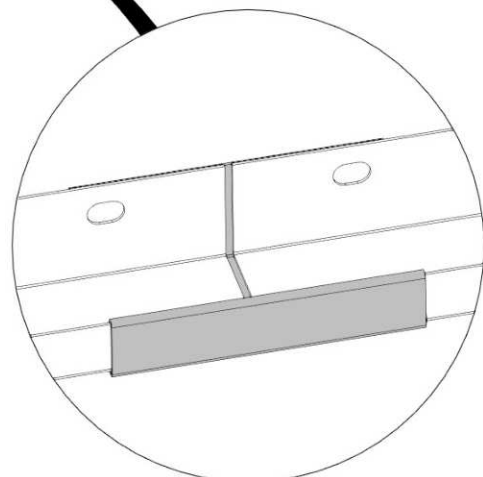

STEP 17B - GUTTER ATTACHMENT

QTY	PART NUMBER	DESCRIPTION
8	H101202	TORX PAN HEAD 1/4-20x3/4 ASSY

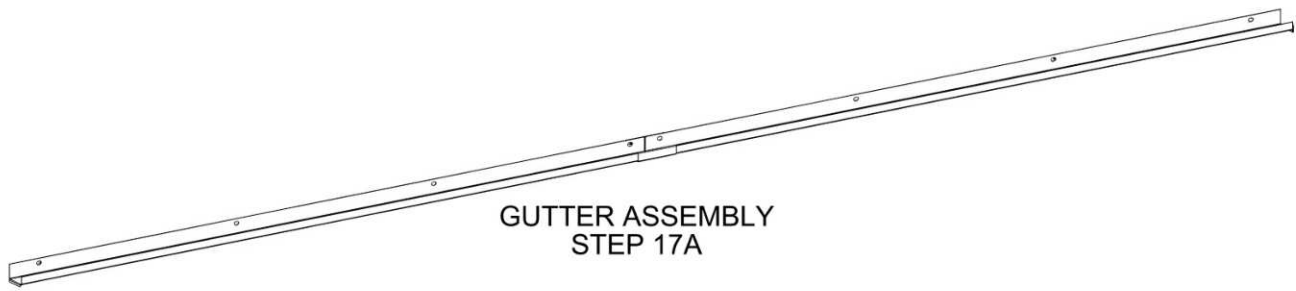

- WITH AT LEAST TWO PEOPLE ATTACH GUTTER ASSEMBLY FROM PREVIOUS STEP TO BEAM.
- MAKE SURE ENDS OF GUTTER SIT ON TOP SURFACE OF EACH POST BRACKET.

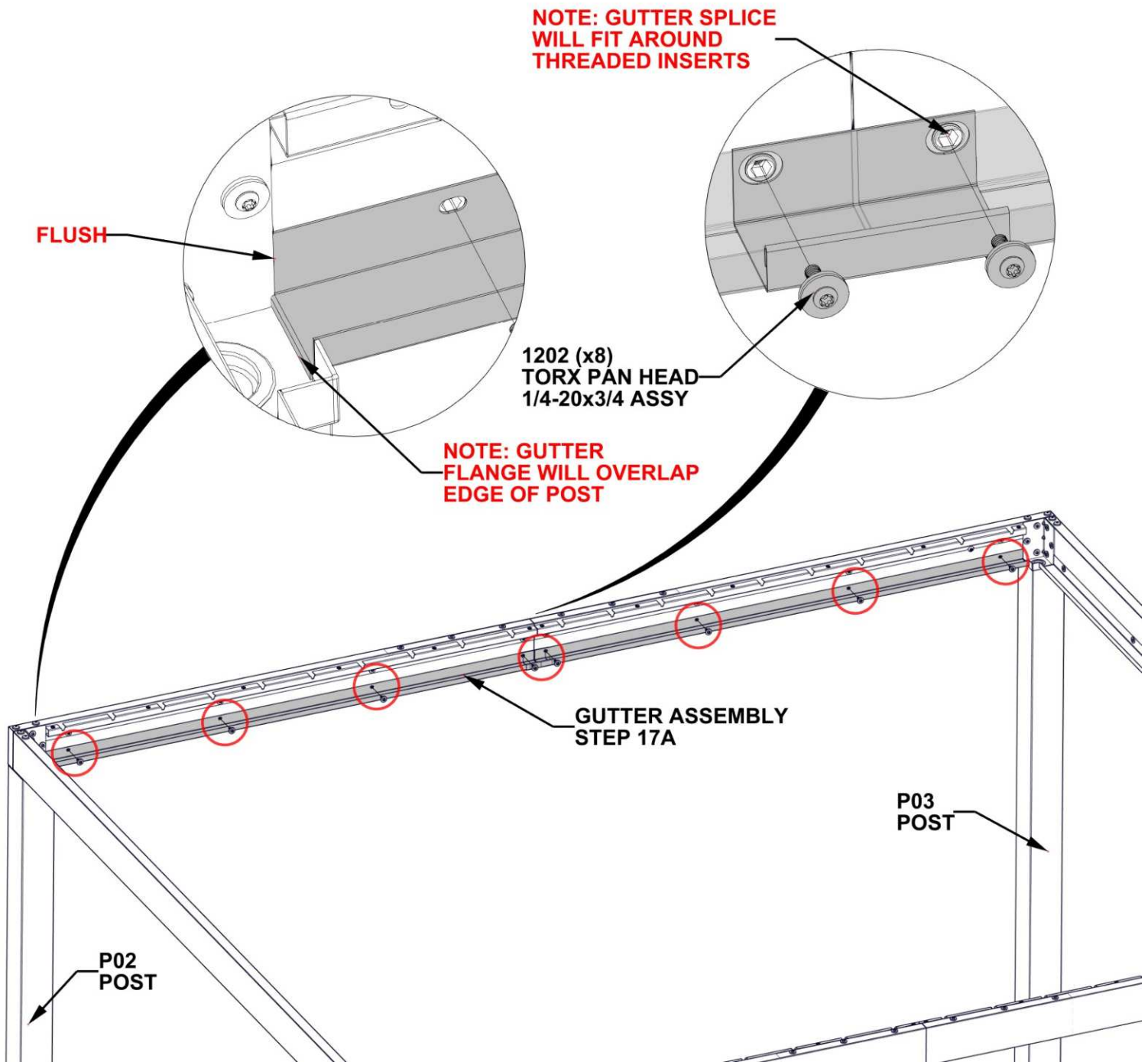

STEP 17C - GUTTER ATTACHMENT



A6P00796 SILICONE
(x1)

- APPLY A FINE BEAD OF SILICONE ALONG INSIDE SURFACE OF GUTTER WHERE TWO GUTTER PIECES MEET.
- SMOOTH SILICONE ALONG SEAM, WIPING EXCESS USING A RAG OR PAPER TOWEL
- GLOVES ARE RECOMMENDED WHEN APPLYING SILICONE.
- MAKE SURE SURFACE OF GUTTER IS CLEAN, DRY, AND FREE OF ANY DIRT/DEBRIS

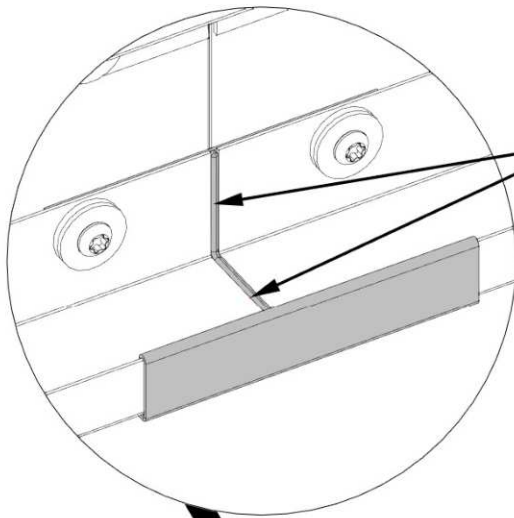

NOTE: APPLY A FINE BEAD OF SILICONE ALONG INSIDE SEAM OF GUTTER

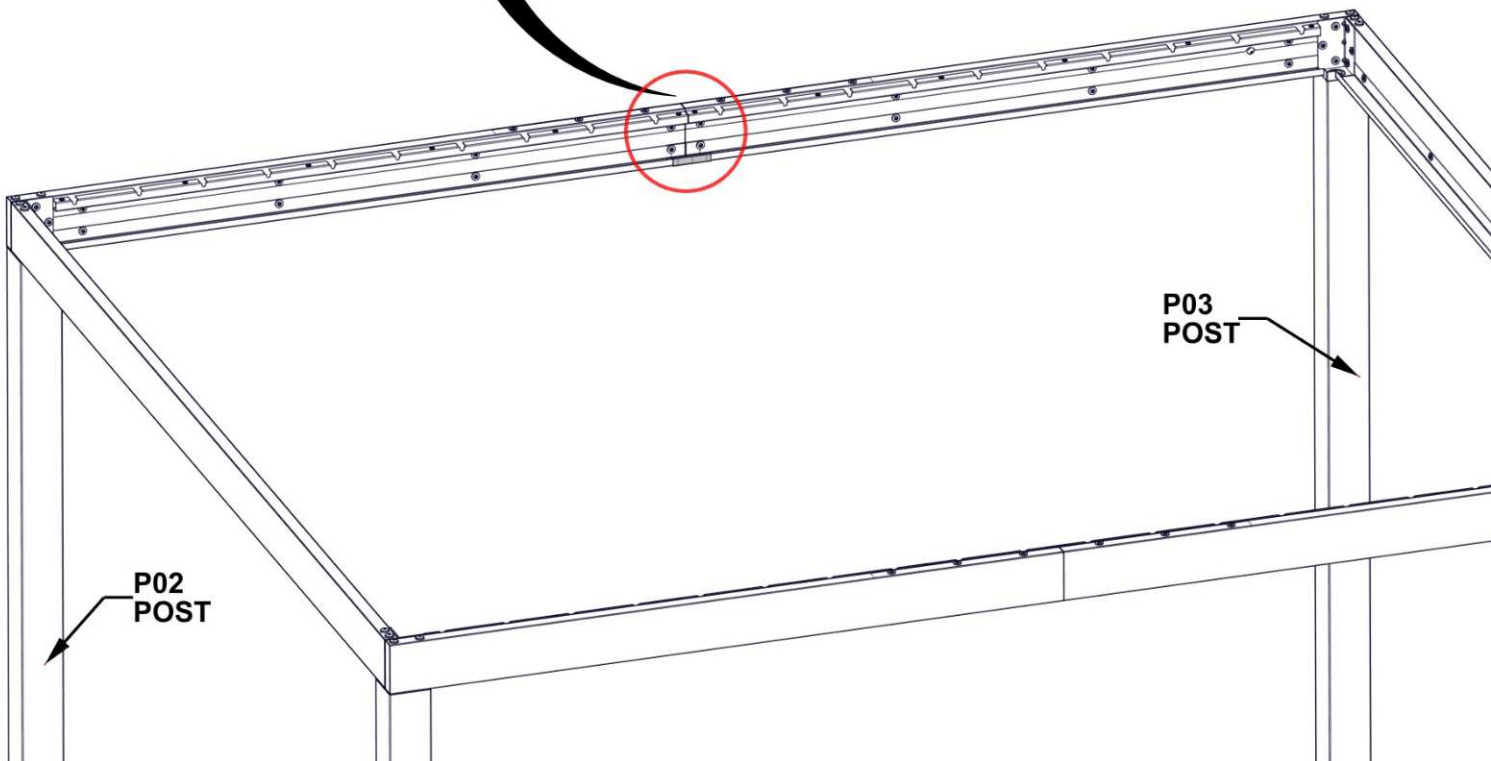

STEP 18A - SQUARE STRUCTURE

- CRITICAL:**
1. SQUARE ASSEMBLY BEFORE PROCEEDING TO NEXT STEPS.
2. ONCE SQUARE, TIGHTEN ALL HARDWARE.

MEASUREMENTS TAKEN FROM OUTSIDE POST TO OUTSIDE POST OF STRUCTURE UNLESS NOTED OTHERWISE

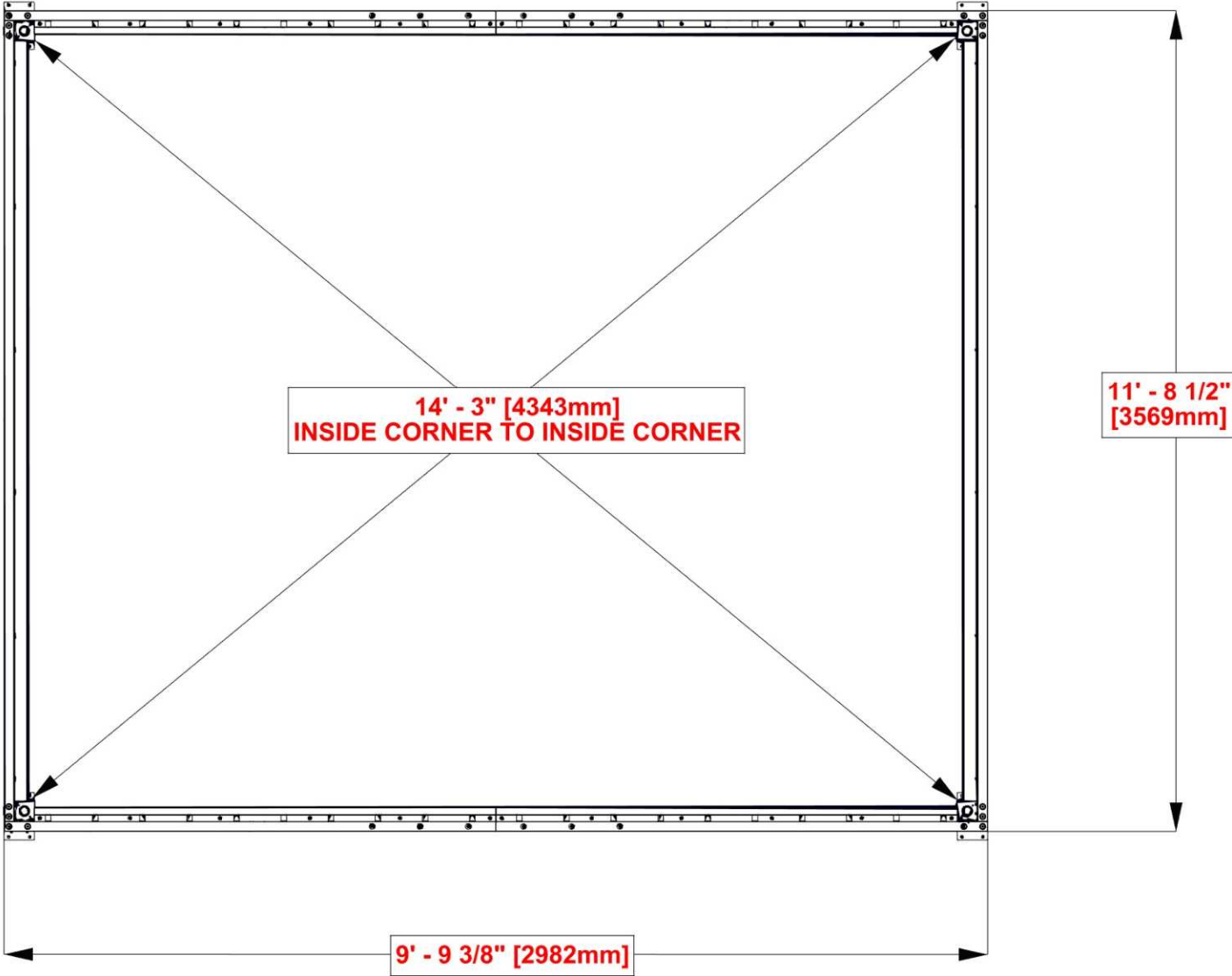

STEP 18B - POSITIONING THE STRUCTURE

CRITICAL:

- FOR YOUR PERGOLA TO DRAIN PROPERLY, THERE MUST BE A SLIGHT SLOPE ON THE 10FT SIDE RUNNING THE LENGTH OF THE LOUVER BLADES.
- IT IS RECOMMENDED THAT THE LONG SIDES ARE LEVEL OR CLOSE TO LEVEL.
- PLACE A LEVEL ON THE LONGER BEAMS TO CONFIRM THE LONG SIDES ARE CLOSE TO LEVEL.
- PLACE A LEVEL ON THE SHORT BEAMS (10FT) SIDE TO CONFIRM YOU HAVE A SLIGHT SLOPE IN ONE DIRECTION.

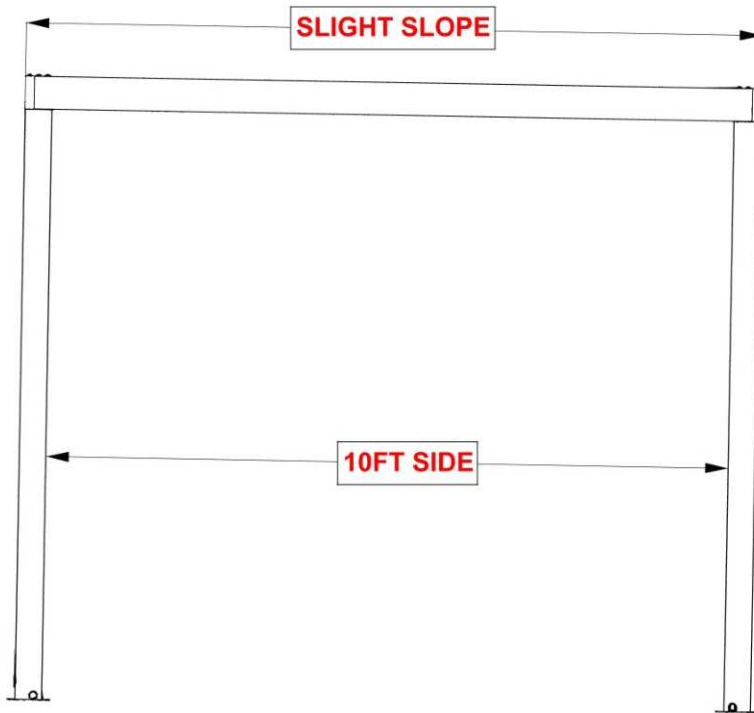
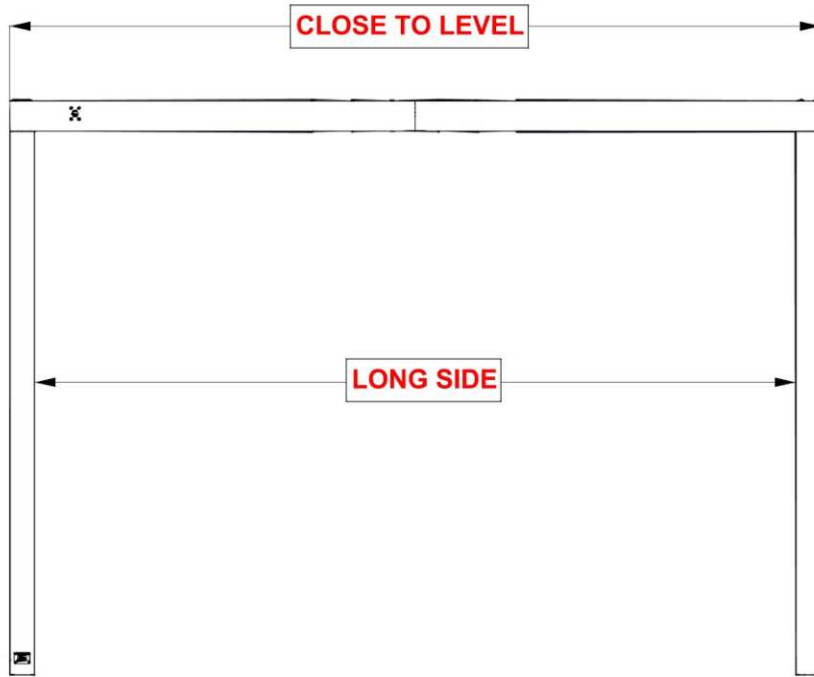

PLEASE CONTACT BACKYARD DISCOVERY CUSTOMER SERVICE
IF HELP IS NEEDED POSITIONING YOUR STRUCTURE

STEP 19 - GUTTER SEALANT



A6P00796 SILICONE
(x1)

- APPLY A FINE BEAD OF SILICONE ALONG INSIDE SURFACE OF GUTTER WHERE GUTTER PIECES MEET POST.
- SMOOTH SILICONE, WIPING EXCESS USING A RAG OR PAPER TOWEL
- REPEAT THIS STEP FOR ALL GUTTER ATTACHMENT POINTS AT EACH POST.
- GLOVES ARE RECOMMENDED WHEN APPLYING SILICONE
- MAKE SURE SURFACE OF GUTTER SPLICE IS CLEAN, DRY, AND FREE OF ANY DIRT/DEBRIS

NOTE: APPLY A FINE BEAD OF SILICONE TO PREVENT WATER FROM LEAKING

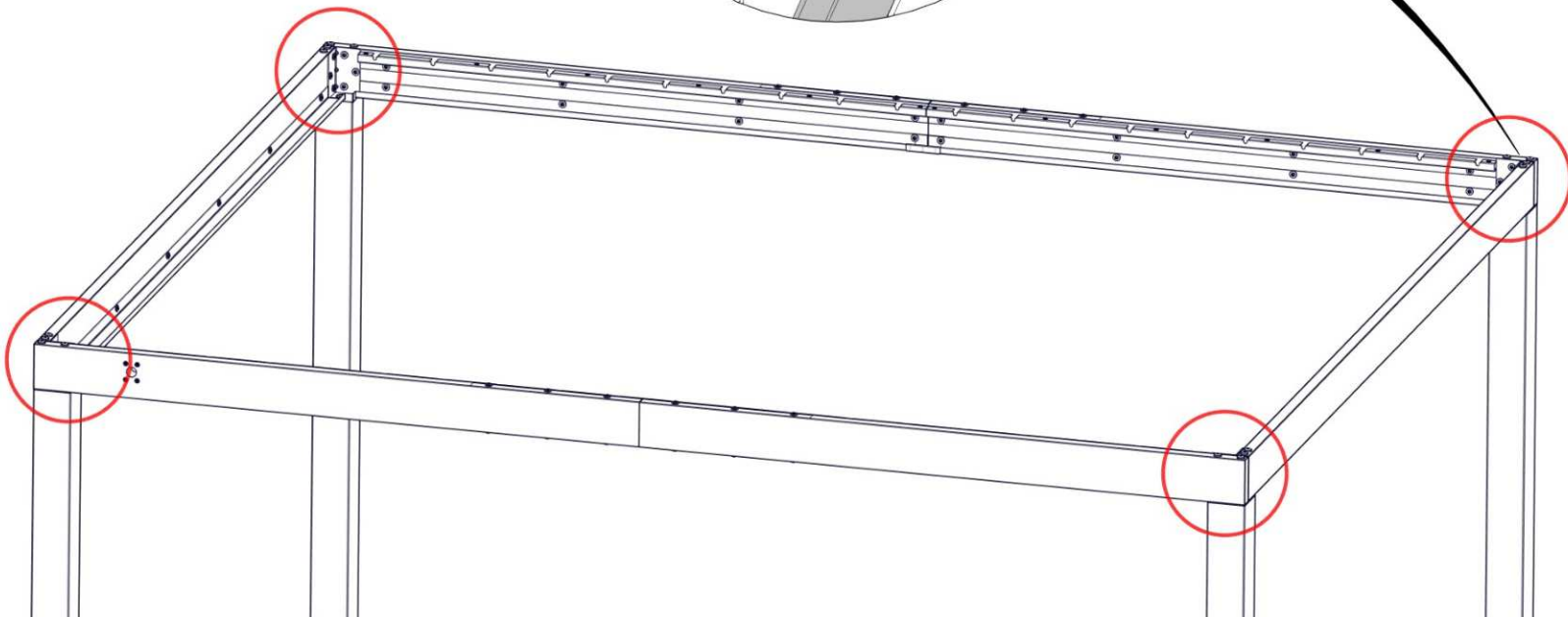
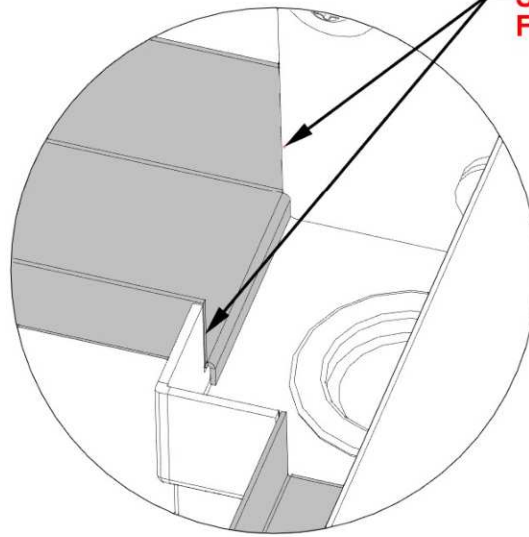

STEP 20 - DRIVE LOUVER ASSEMBLY

QTY	PART NUMBER	DESCRIPTION
4	H100408	SCREW PWH 8x1/2 BLK



L02 LOUVER DRIVE SIDE PLATE - A4M04139
(x1) 1/16"x2 3/16"x6 9/16" (2x55x167)



L03 LOUVER SIDE PLATE - A4M04138
(x1) 1/16"x2 3/16"x6 9/16" (2x55x167)

- DO NOT OVERTIGHTEN SCREWS
- FOR EASE OF ASSEMBLY, WE RECOMMEND USING SAWHORSES FOR THIS STEP.

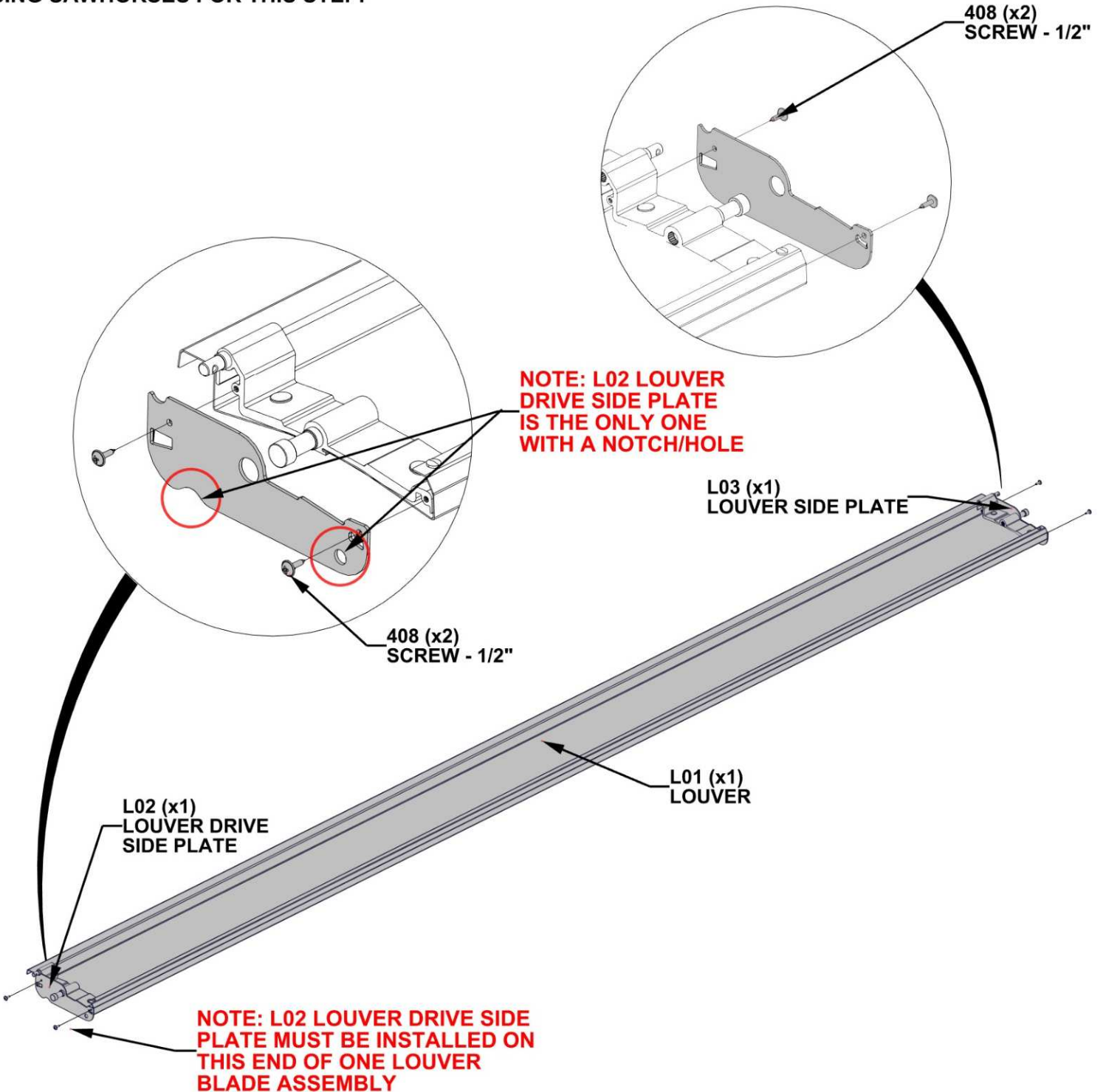

STEP 21 - DRIVE LOUVER INSTALLATION

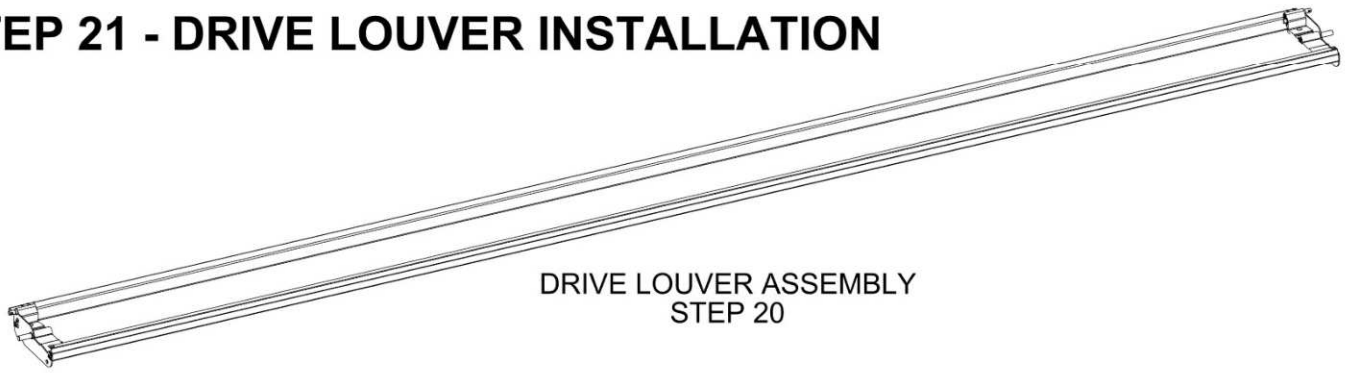

- ORIENTATION OF LOUVER WILL BE DETERMINED BY THE SIDE BEAM WITH FOUR THREADED INSERTS
- PLACE DRIVE LOUVER FROM PREVIOUS STEP IN THE SECOND SET OF LOUVER MOUNT GROOVES. L02 DRIVE PLATE WILL BE ON SAME SIDE AS FOUR THREADED INSERTS IN BEAM.

NOTE: PLACE DRIVE LOUVER ASSEMBLY IN THE SECOND SET OF LOUVER MOUNT GROOVES

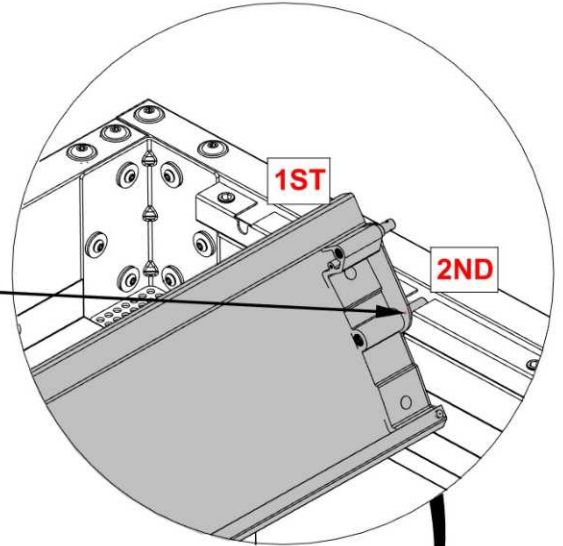

L02
LOUVER DRIVE
SIDE PLATE

NOTE: L02 SIDE PLATE MUST BE ON THE SAME END AS THE FOUR THREADED INSERTS

DRIVE LOUVER
ASSEMBLY
STEP 20

STEP 22 - LOUVER ASSEMBLY

QTY	PART NUMBER	DESCRIPTION
76	H100408	SCREW PWH 8x1/2 BLK

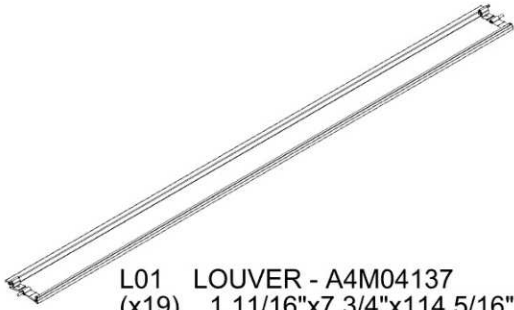

L01 LOUVER - A4M04137
(x19) 1 11/16"x7 3/4"x114 5/16" (42x196x2904)



L03 LOUVER SIDE PLATE - A4M04138
(x38) 1/16"x2 3/16"x6 9/16" (2x55x167)

REPEAT THIS STEP 19 TIMES

- DO NOT OVERTIGHTEN SCREWS

- FOR EASE OF ASSEMBLY, WE RECOMMEND USING SAWHORSES FOR THIS STEP.

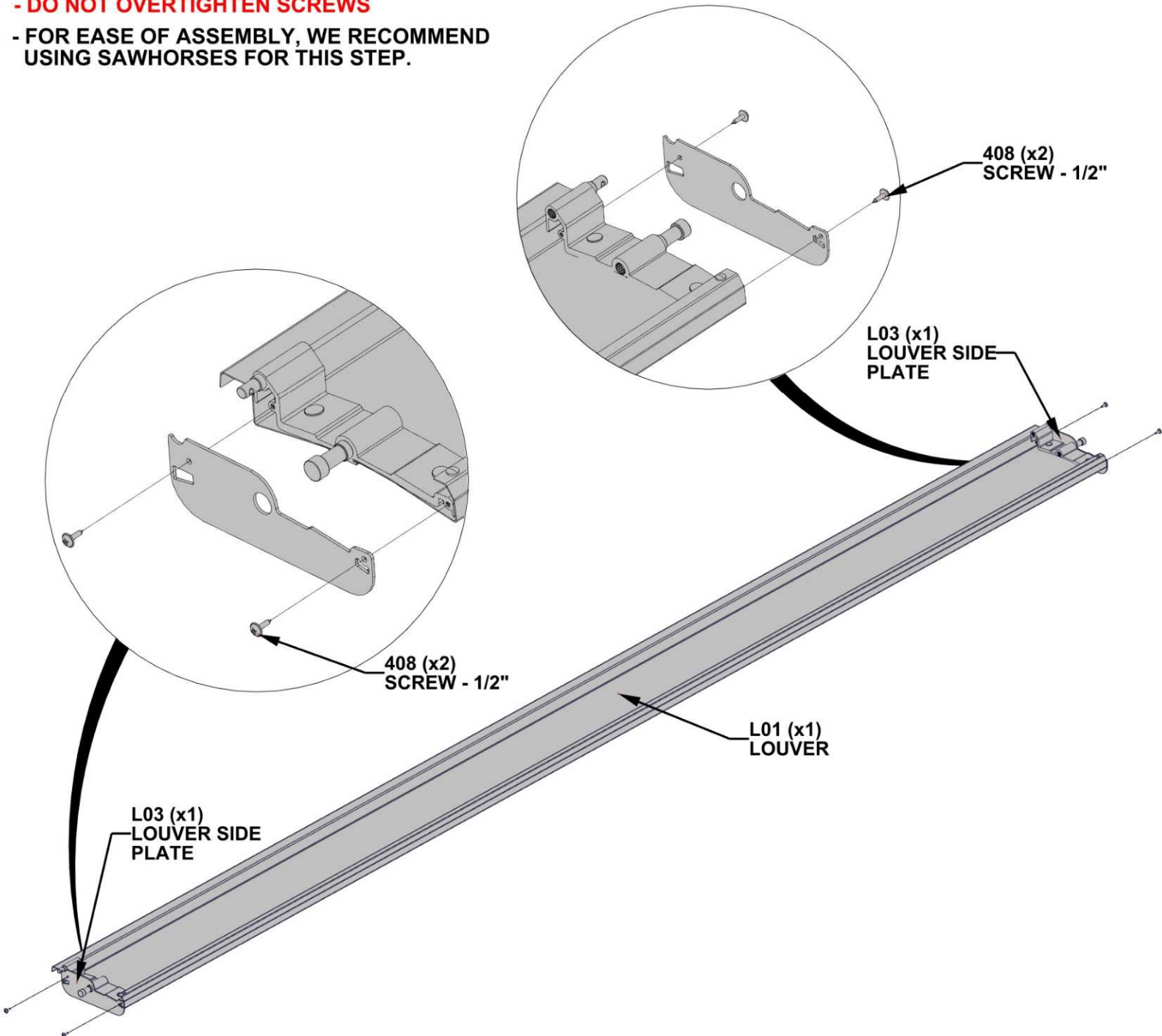

STEP 23 - LOUVER INSTALLATION

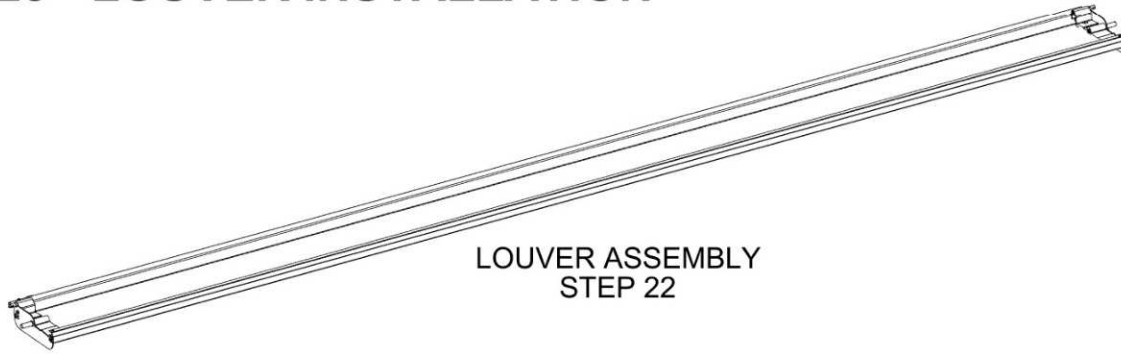

STARTING AT THE LEFT SIDE AND WORKING TO THE RIGHT, CAREFULLY SET EACH LOUVER ASSEMBLY ONE AT A TIME INTO LOUVER MOUNTS AT EACH END

NOTE: MAKE SURE ALL LOUVER BLADE ASSEMBLIES ARE ORIENTED IN THE SAME DIRECTION

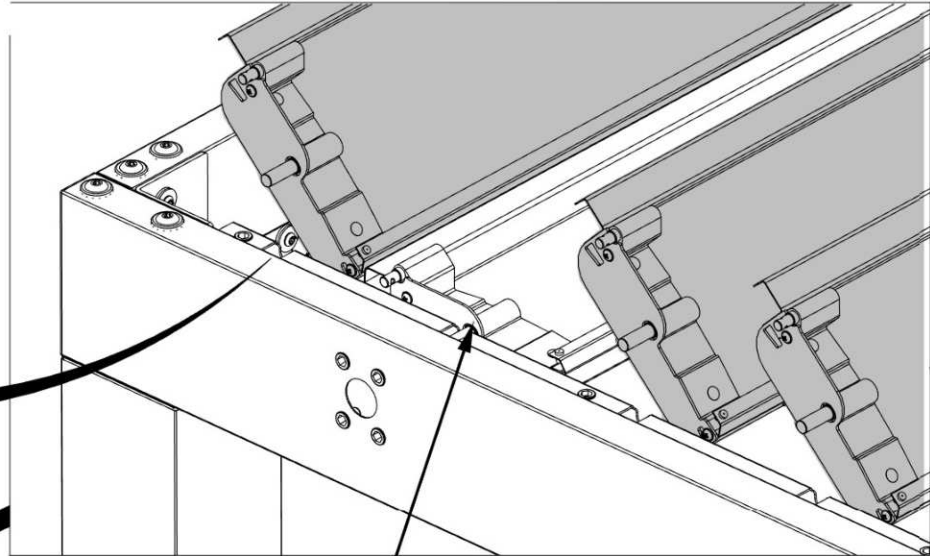
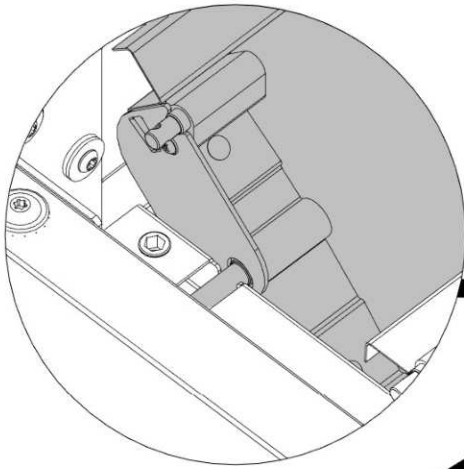

DRIVE LOUVER FROM STEP 21

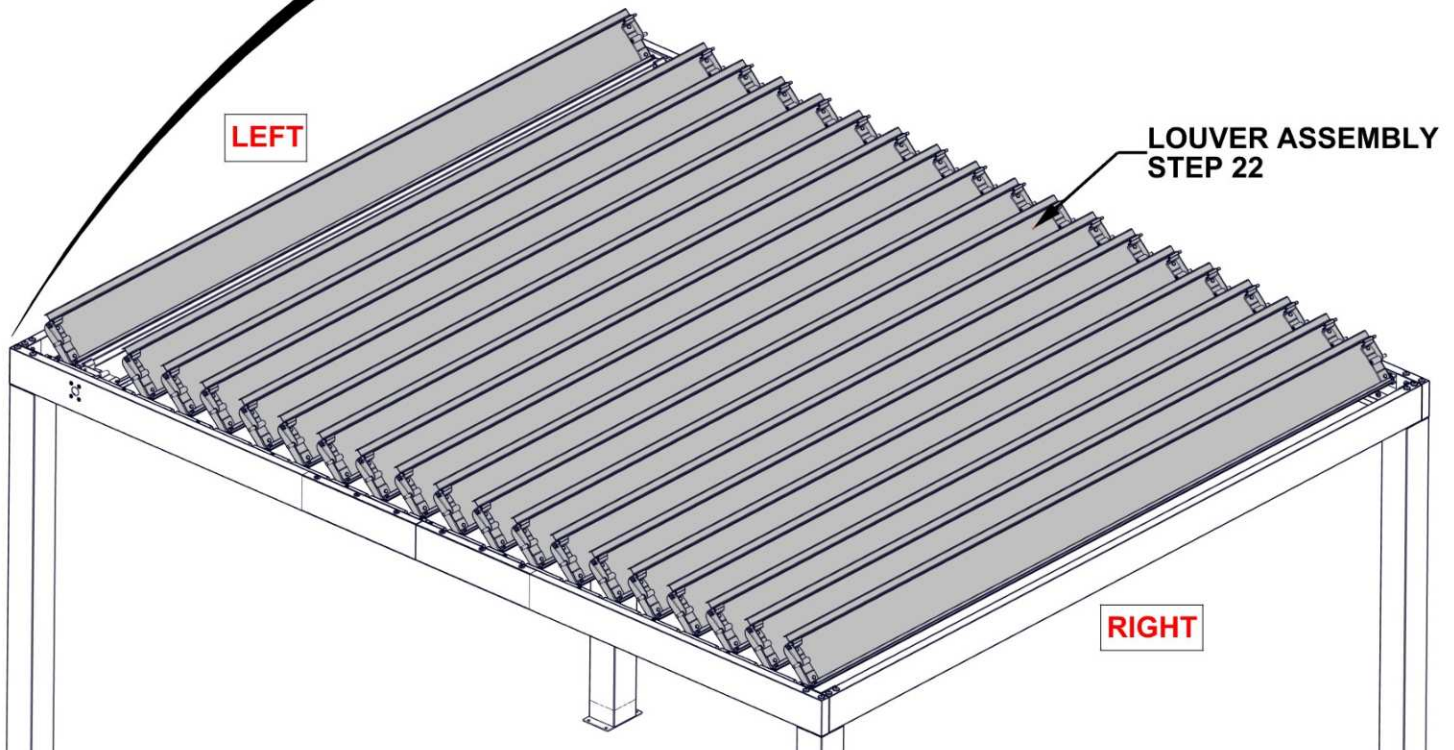

STEP 24 - LOUVER INSTALLATION

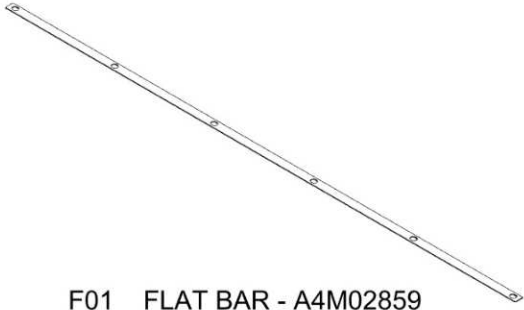

QTY	PART NUMBER	DESCRIPTION
24	H101202	TORX PAN HEAD 1/4-20x3/4 ASSY

F01 FLAT BAR - A4M02859
(x4) 1/16"x1"x65 7/8" (2x25x1673)

- ATTACH FLAT BAR ALONG EACH LOUVER MOUNT.
- FLAT BAR WILL HOLD ALL LOUVERS IN PLACE.

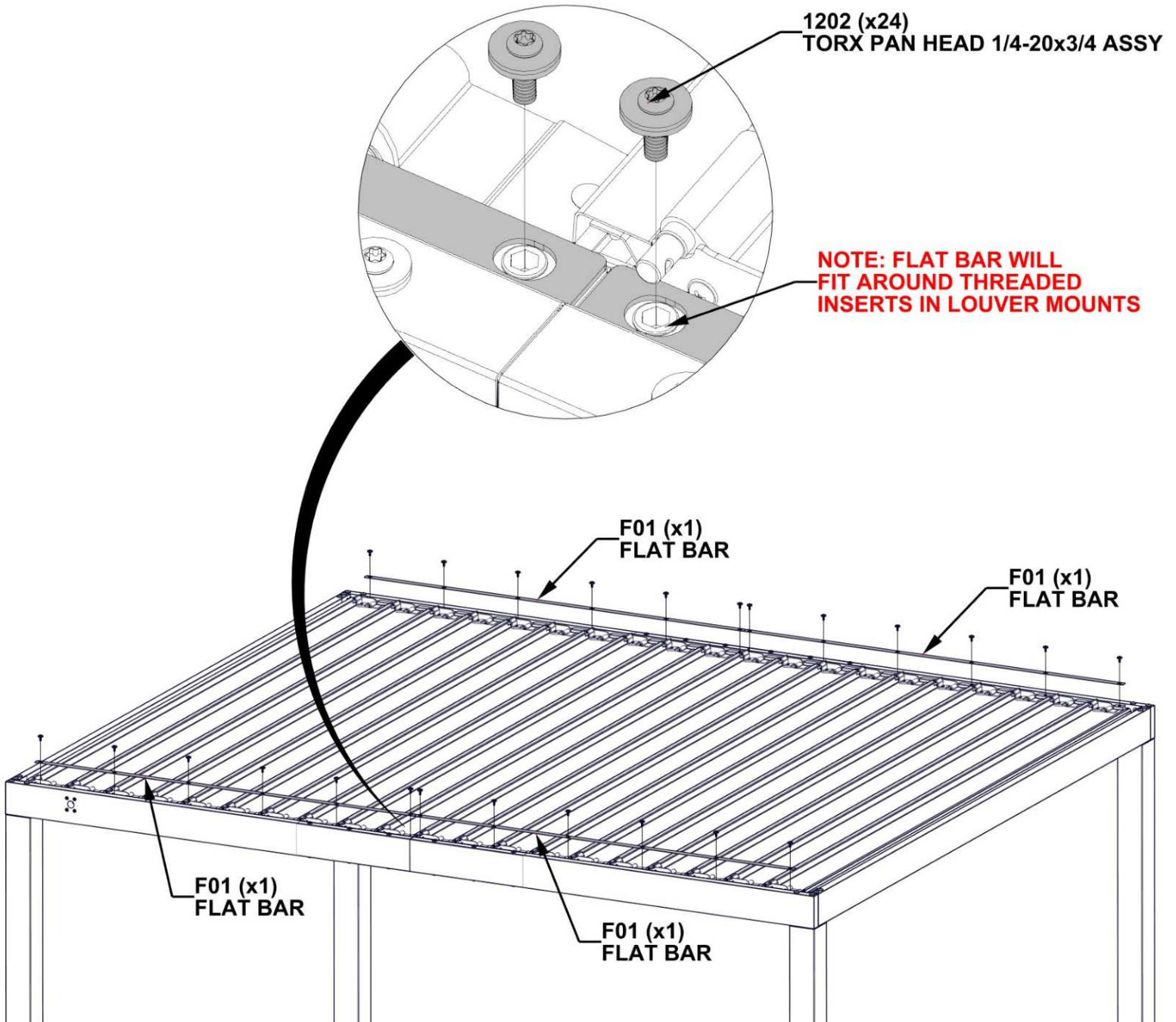

STEP 25A - LOUVER INSTALLATION

F02 LOUVER TIE STRAP - A4M02860
(x4) 1/8"x13/16"x68 1/16" (3x20x1730)

- LOUVER TIE STRAPS WILL CONNECT ALL LOUVERS TO ONE ANOTHER
- STARTING ON THE LEFT AND WORKING TO THE RIGHT, CONNECT LOUVERS USING TIE STRAPS. OVERLAP TIE STRAPS TO HOLD MIDDLE LOUVERS TOGETHER

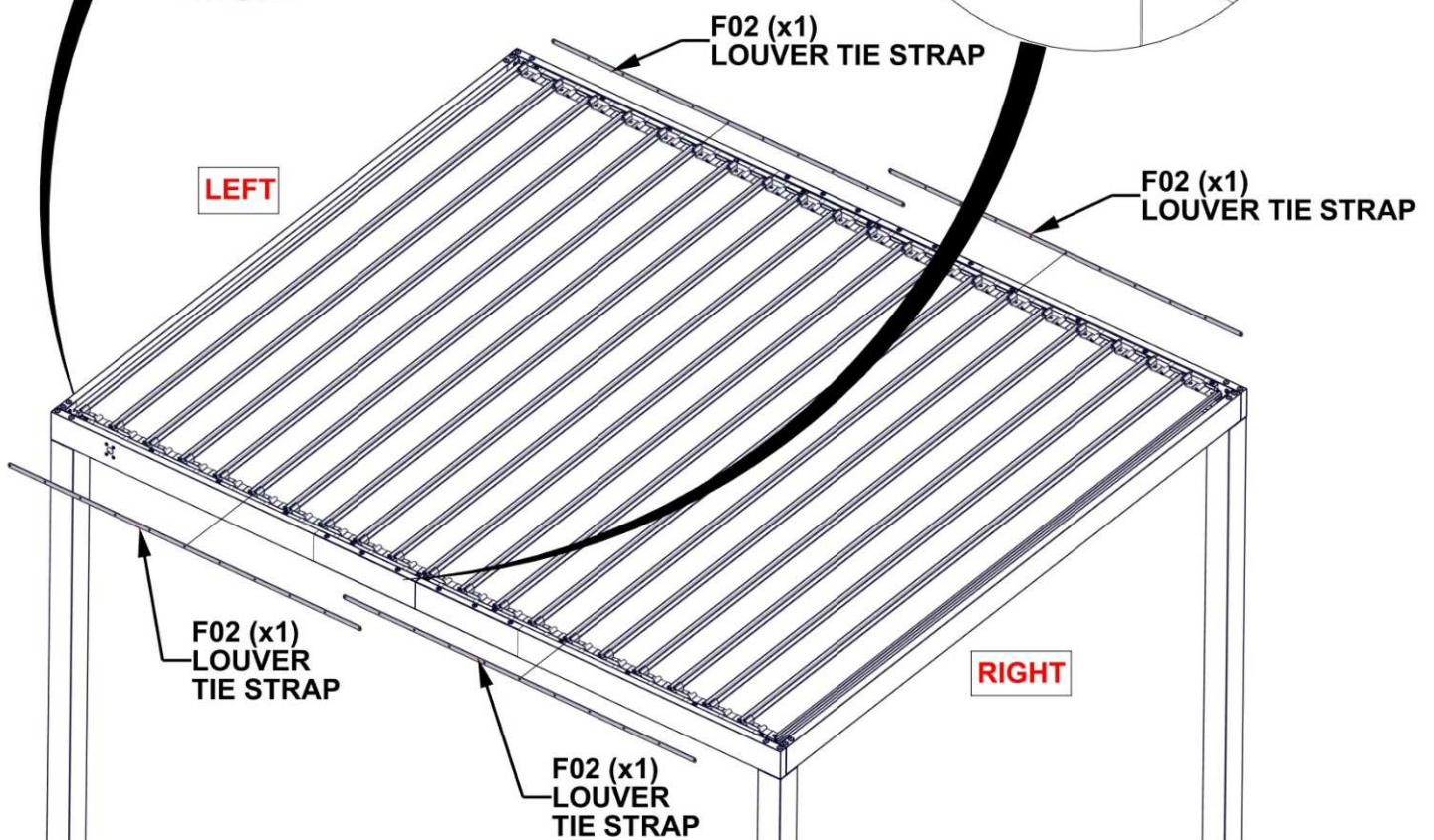
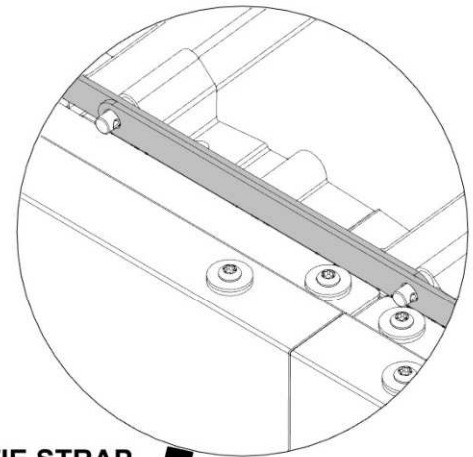
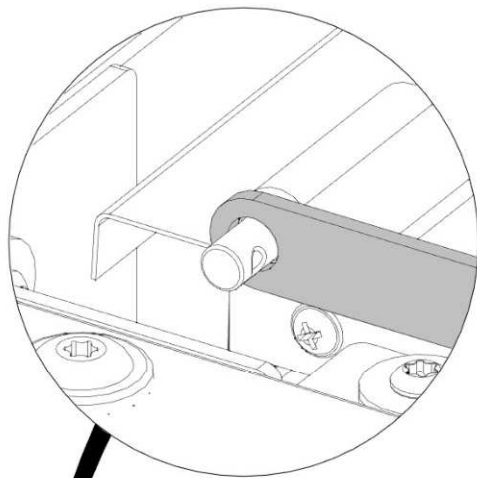
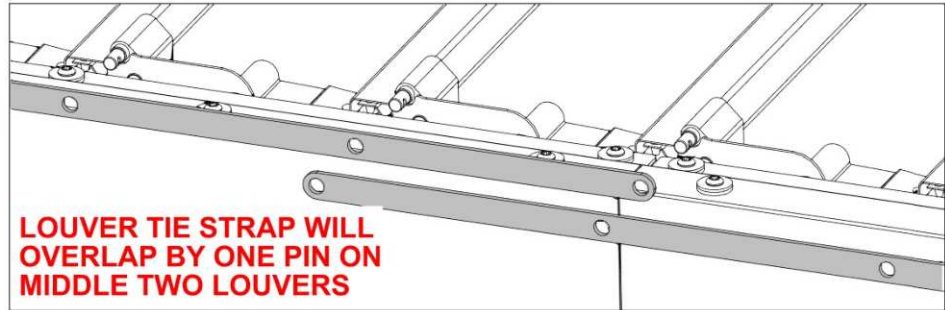

STEP 25B - LOUVER INSTALLATION

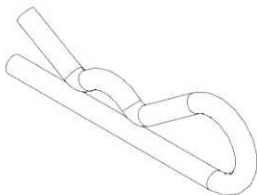

H101161 COTTER PIN
(x40)

**- INTALL COTTER PINS ON EACH LOUVER
TO HOLD TIE STRAPS IN PLACE.**

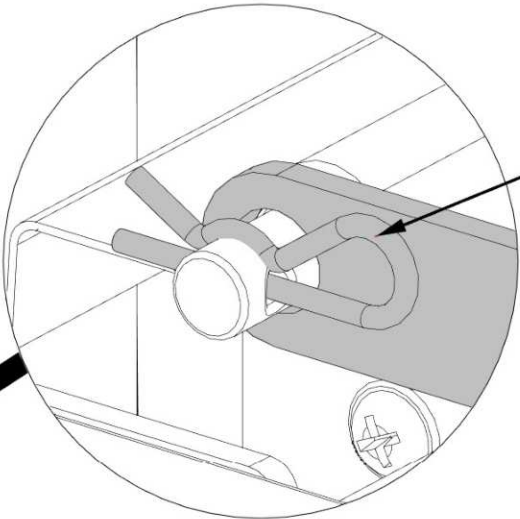

1161 (x40)
COTTER PIN

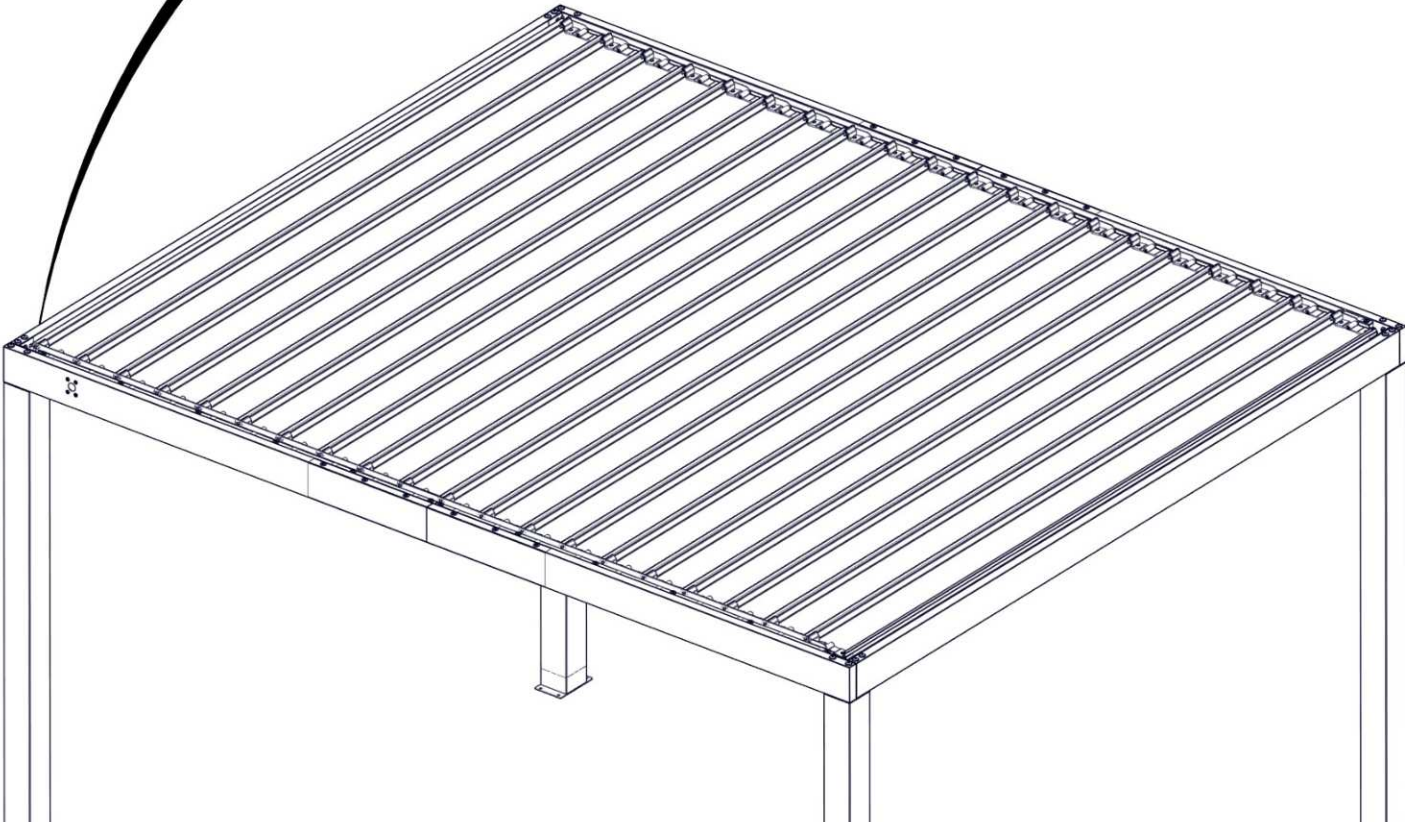

STEP 26 - LOUVER MECHANISM

QTY	PART NUMBER	DESCRIPTION
4	H101126	TORX PAN HEAD 1/4-20x2 1/8"



L04 LOUVER MECHANISM
(x1) A4M02132



F06 SPACER - A4M02227
(x1) 1/16"x2 3/16"x2 3/4" (1.5x56x70)

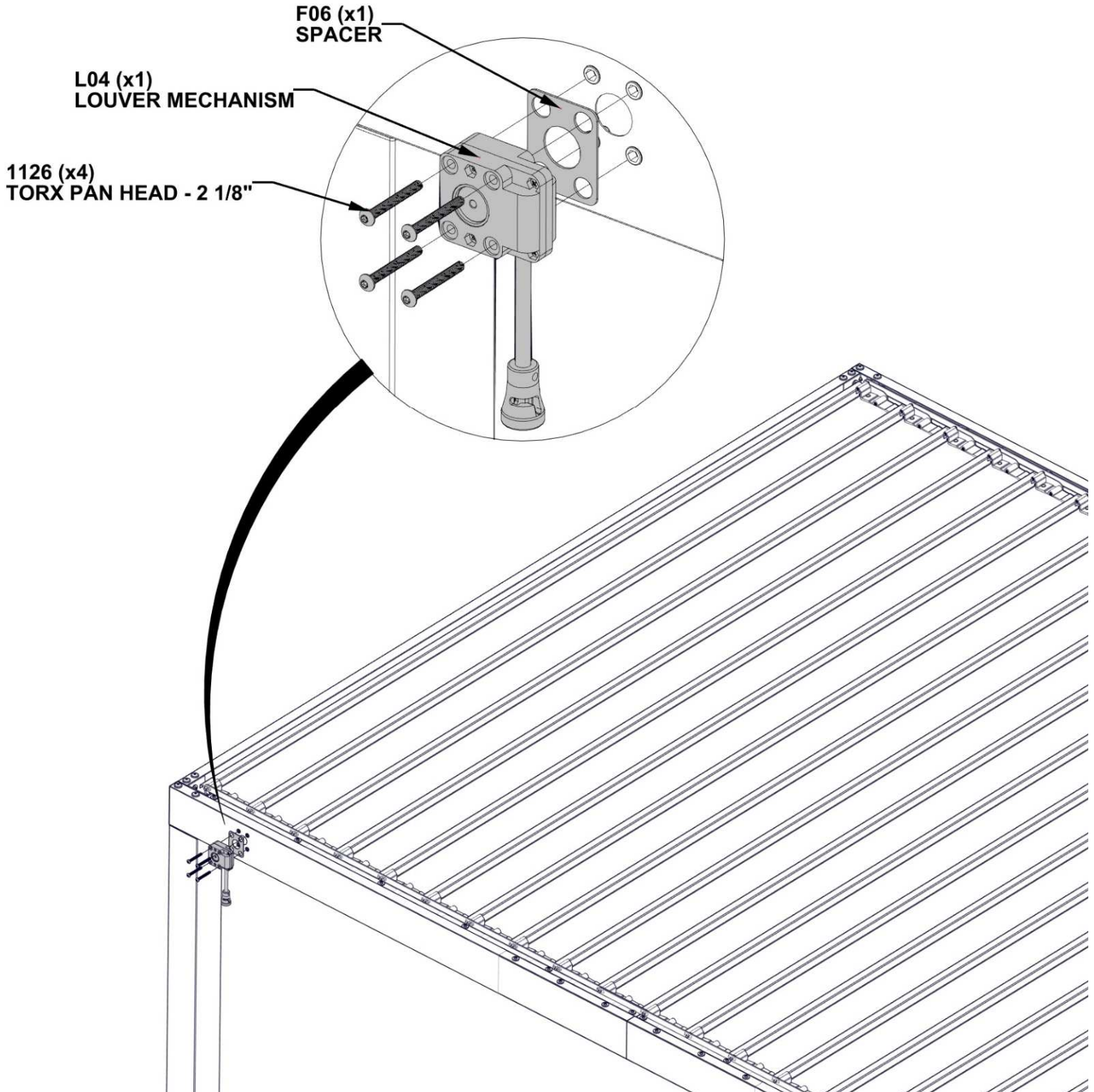

STEP 27 - LOUVER MECHANISM

QTY	PART NUMBER	DESCRIPTION
1	H101187	BOLT PPH 8-32x1 1/8 BLK



F07 COVER - A4M02228
(x1) 1 9/16"x2 7/8"x3 1/4" (39.5x73x82)



F05 KEY STOCK - A4M02226
(x1) 1/2"x1/2"x3 3/4" (13x13x95)

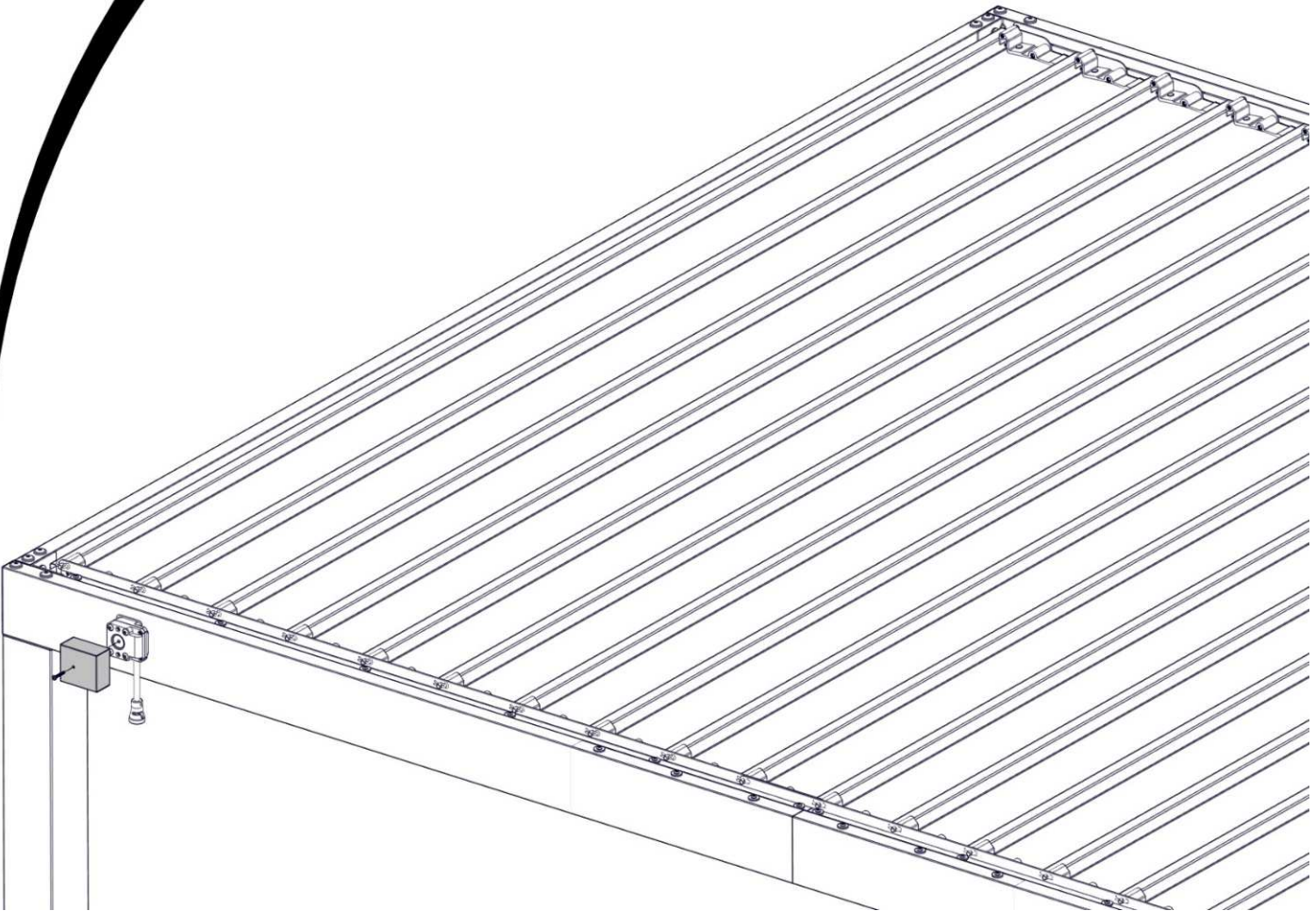
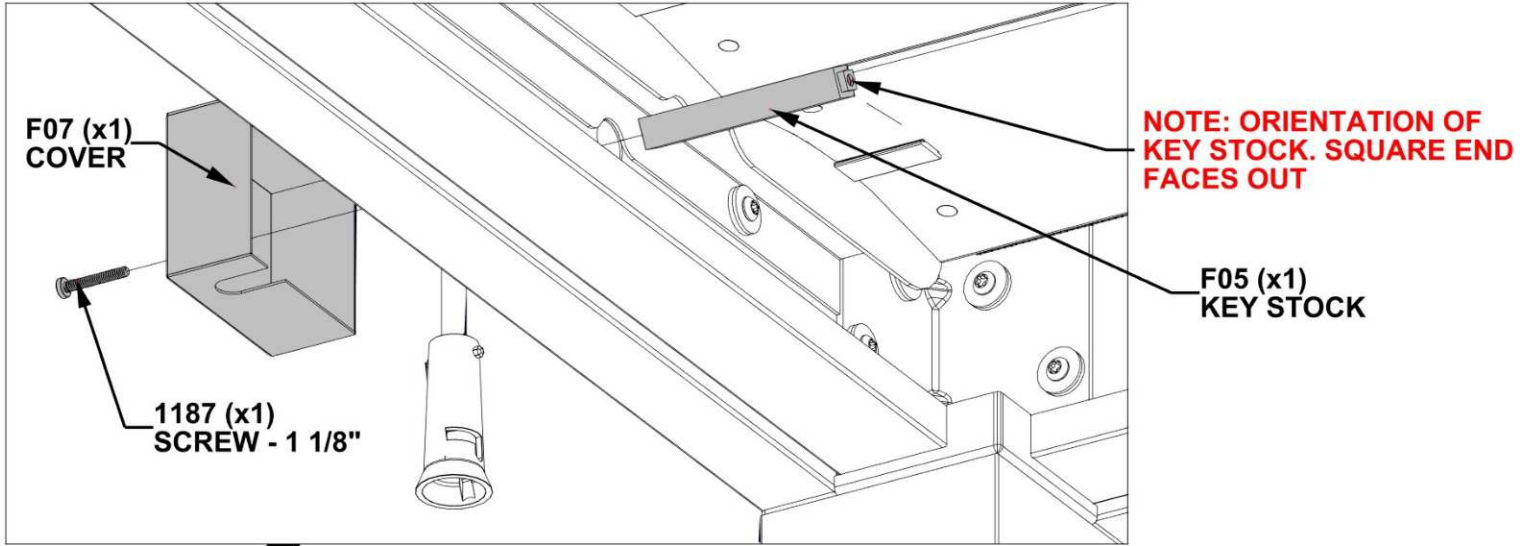

STEP 28A - LOUVER MECHANISM

QTY	PART NUMBER	DESCRIPTION
1	H101189	LOW PROFILE SHOULDER BOLT 1/4-20x.375
1	H100653	NUT LOCK 1/4 BLK
2	H100474	WASHER FLAT 9x18 BLK

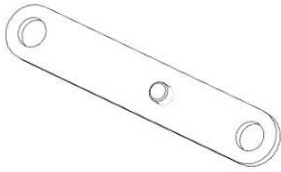

F03 LINKAGE STRAP - A4M02229
(x1) 1/2"x11/16"x3 13/16" (13x17x97)

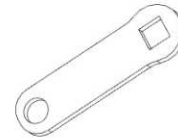

F04 LINKAGE STRAP - A4M02225
(x1) 1/8"x13/16"x2 5/8" (3x20x66)

- LINKAGE MUST BE ORIENTED AS SHOWN BELOW.
- DO NOT OVERTIGHTEN HARDWARE.
- LINKAGES SHOULD BE ABLE TO ROTATE FREELY.

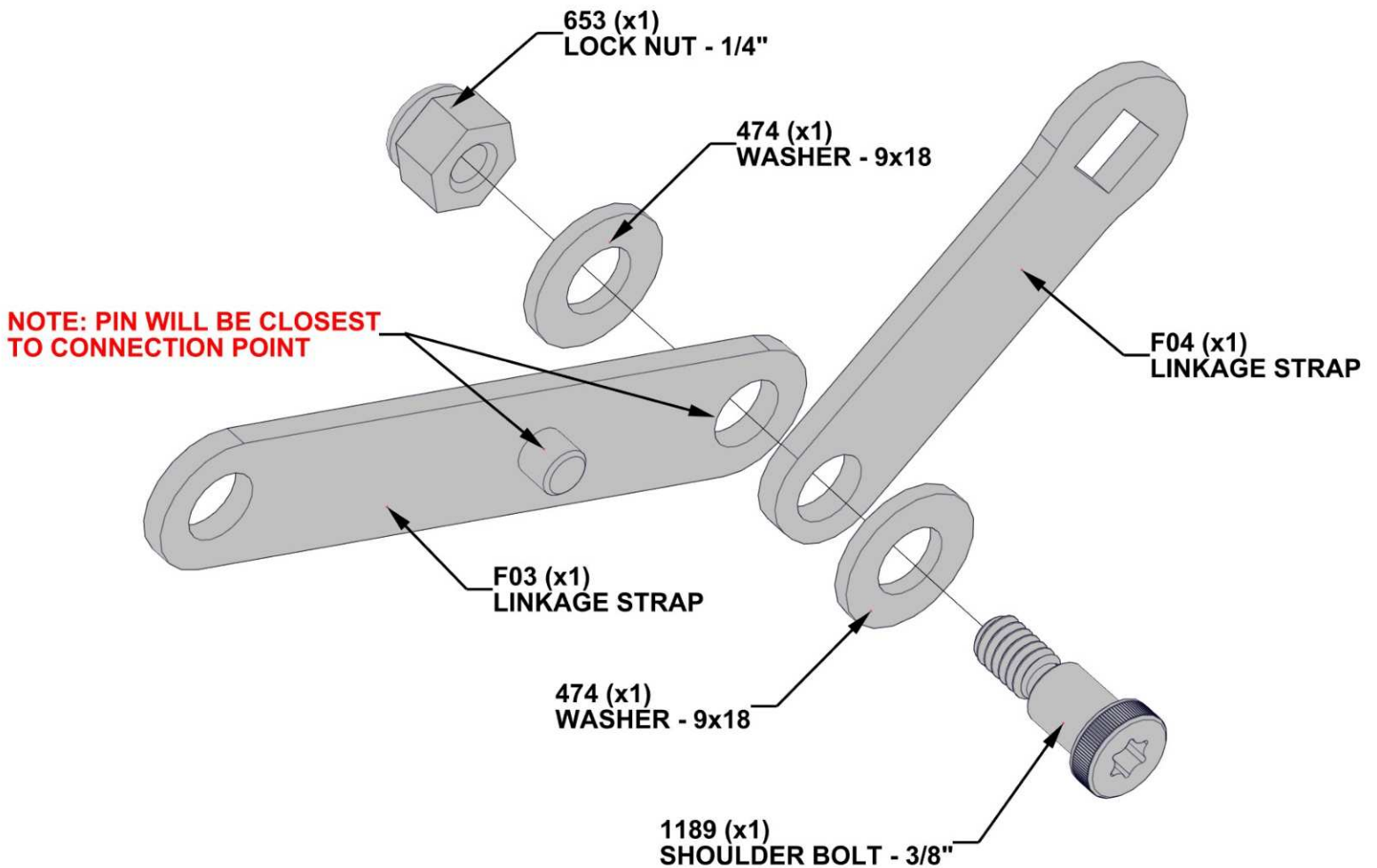

STEP 28B - LOUVER MECHANISM

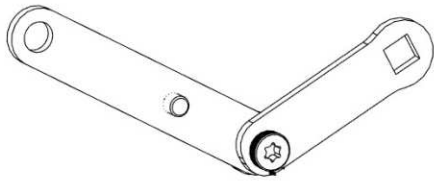

LINKAGE ASSEMBLY
STEP 28A

QTY	PART NUMBER	DESCRIPTION
1	H101101	TORX PAN HEAD 1/4-20x3/4"
1	H100774	WASHER SPLIT 1/4 BLK
1	H101189	LOW PROFILE SHOULDER BOLT 1/4-20x.375
1	H100653	NUT LOCK 1/4 BLK
3	H100474	WASHER FLAT 9x18 BLK

- LINKAGES MUST BE ORIENTED AS SHOWN BELOW.
- DO NOT OVERTIGHTEN HARDWARE.
- LINKAGES SHOULD BE ABLE TO ROTATE FREELY.

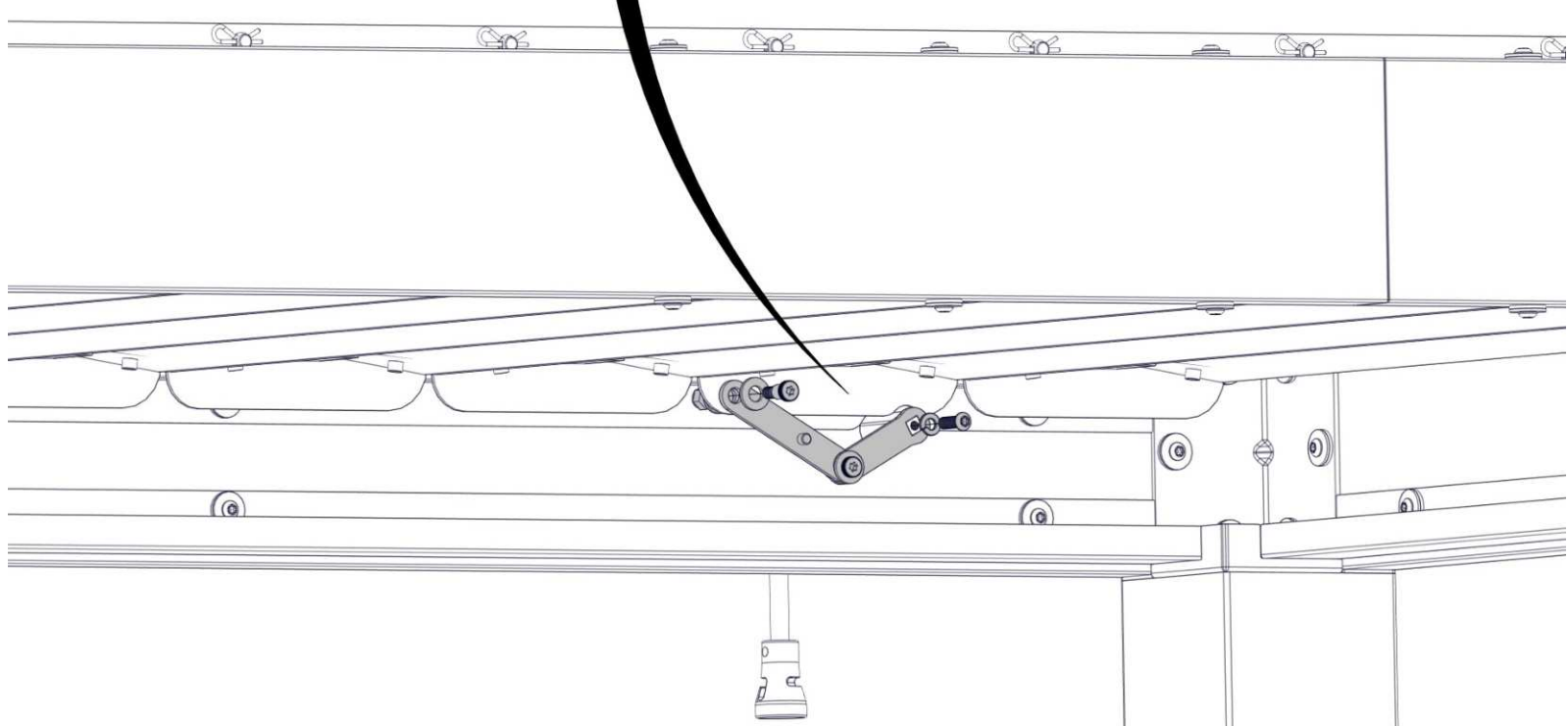
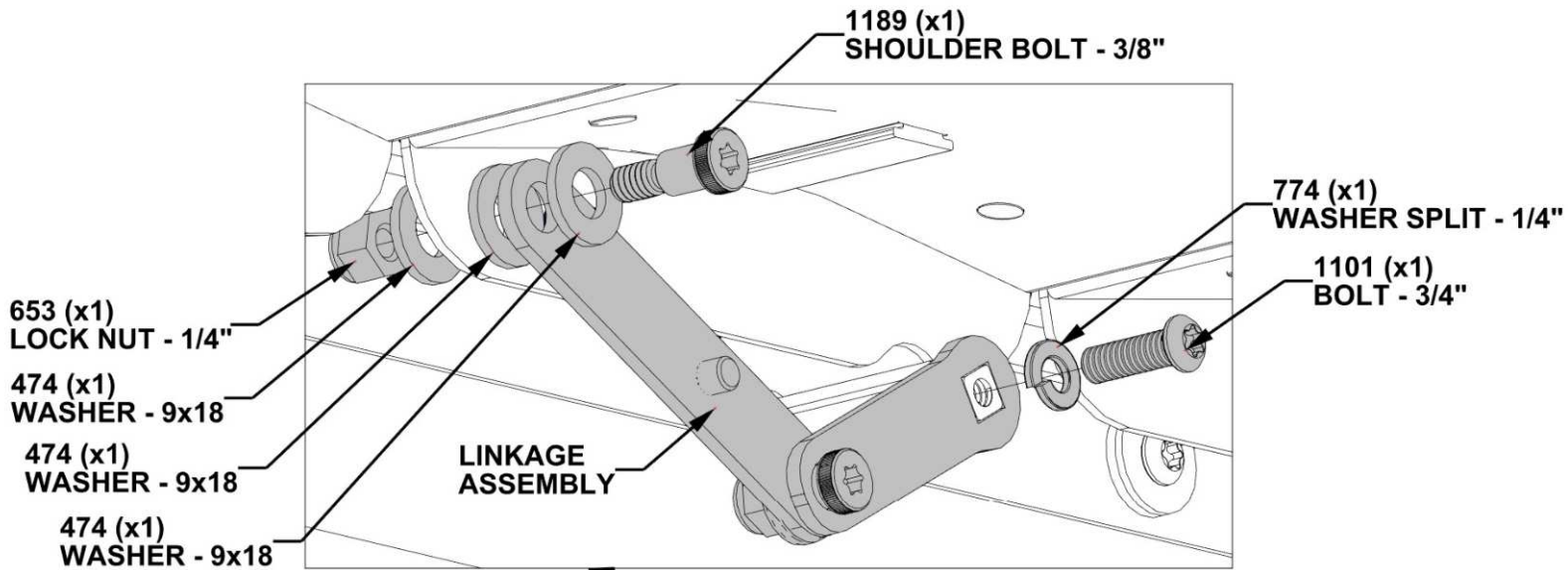

STEP 28C - LOUVER MECHANISM



H01 (x1) HANDLE
A4M04022

**- CONNECT CRANK HANDLE TO MECHANISM.
TURN HANDLE TO LOCK IN PLACE.**

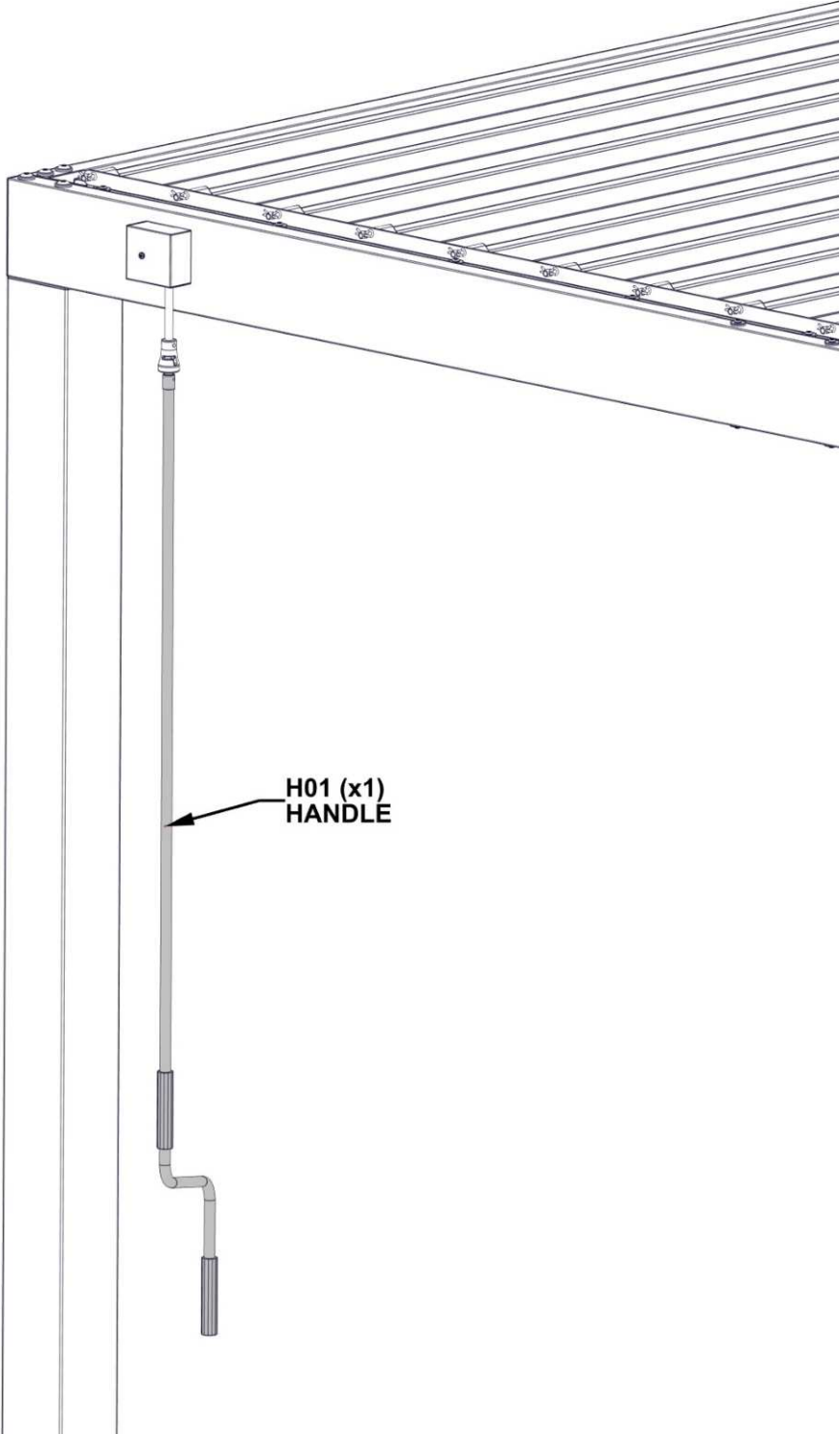

STEP 29 - PERGOLA ANCHORING

QTY	PART NUMBER	DESCRIPTION
16	H100120	CONCRETE ANCHOR 1/4"x2"
16	H100630	WASHER FLAT 8x19 BLK

REPEAT THIS STEP FOR ALL FOUR POSTS

- MANUFACTURER RECOMMENDS INSTALLATION ON CONCRETE SURFACE OR CONCRETE POST PADS. SEE BELOW.
- FOR INSTALLATION ON WOOD DECKS, YOU MUST ENSURE THERE IS AMPLE STRUCTURAL SUPPORT UNDER DECK.

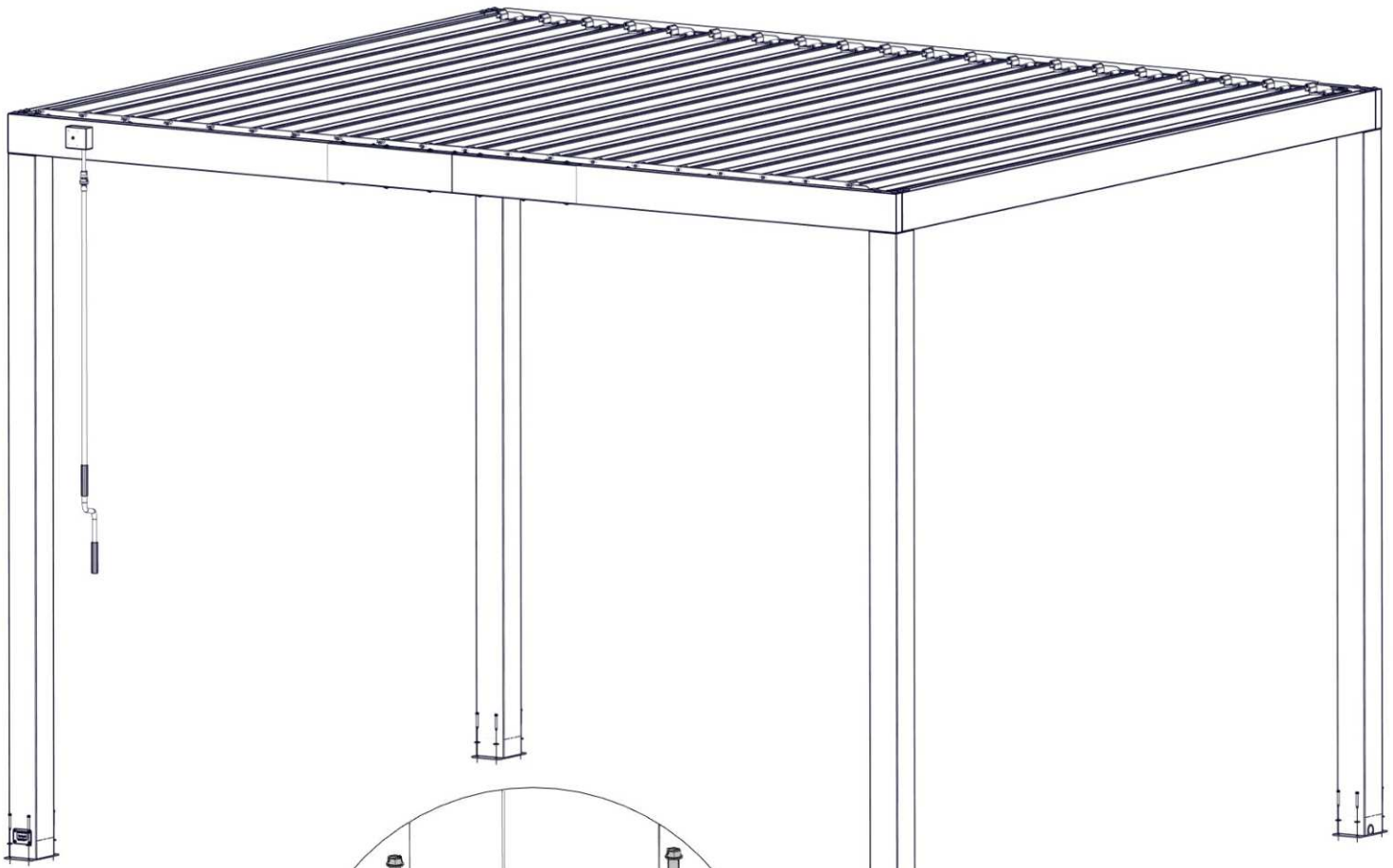

120 (x4)
CONCRETE SCREW-2"

630 (x4)
WASHER - 8x19

PRE-DRILL HOLES FOR
CONCRETE ANCHORS
USING A 3/16" (5mm)
CONCRETE DRILL BIT

STEP 30 - PREVENTATIVE MAINTENANCE

IT IS IMPORTANT TO TAKE CAUTION WHEN HIGH WINDS OR WINTER WEATHER SUCH AS ICE OR SNOW IS EXPECTED.
- FOR HIGH WINDS, IT IS RECOMMENDED TO TURN LOUVERS INTO THE CLOSED POSITION.
- FOR INCLEMENT WEATHER SUCH AS SNOW OR ICE, IT IS RECOMMENDED TO TURN LOUVERS INTO THE FULLY OPEN (UPRIGHT) POSITION.

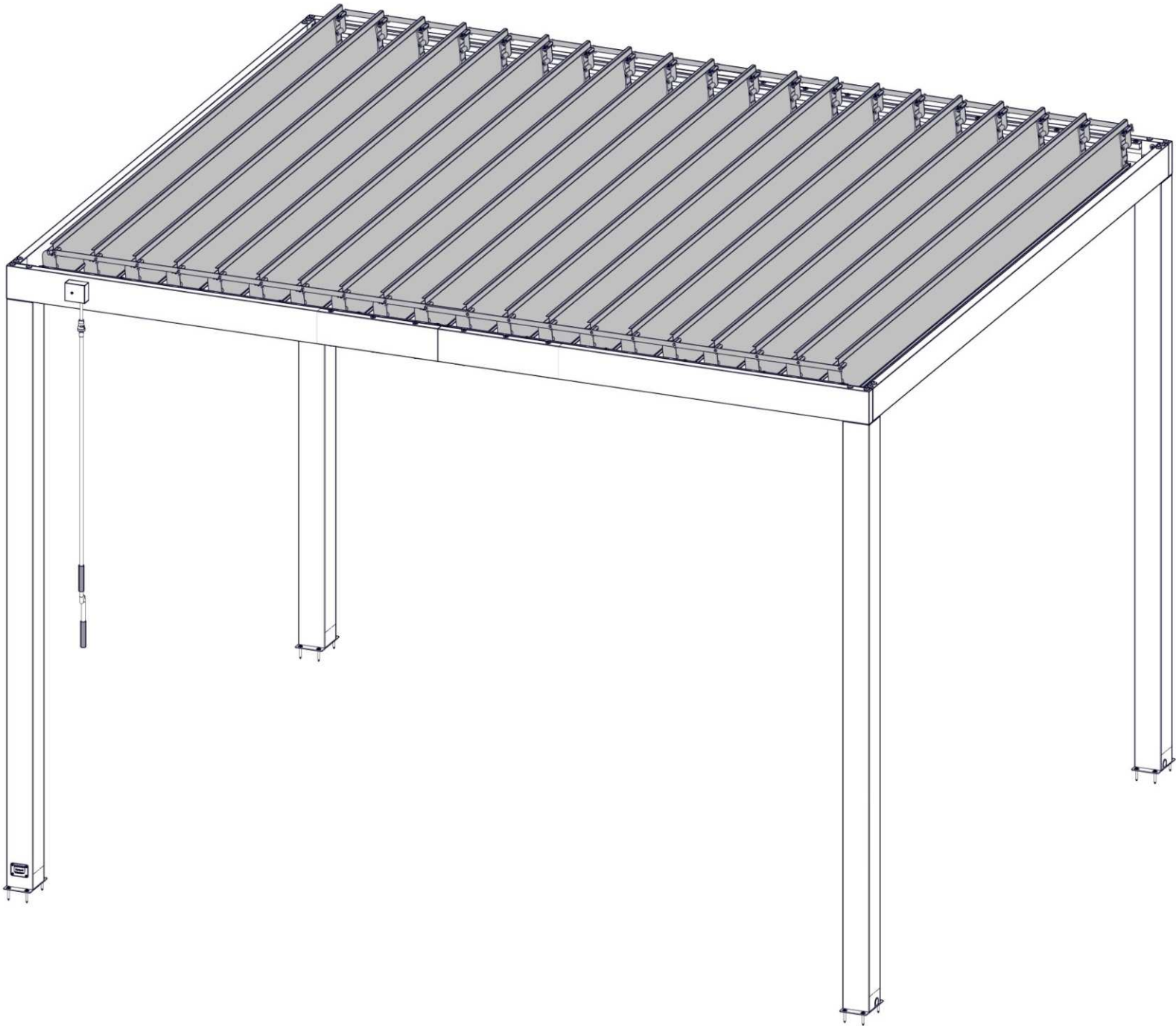

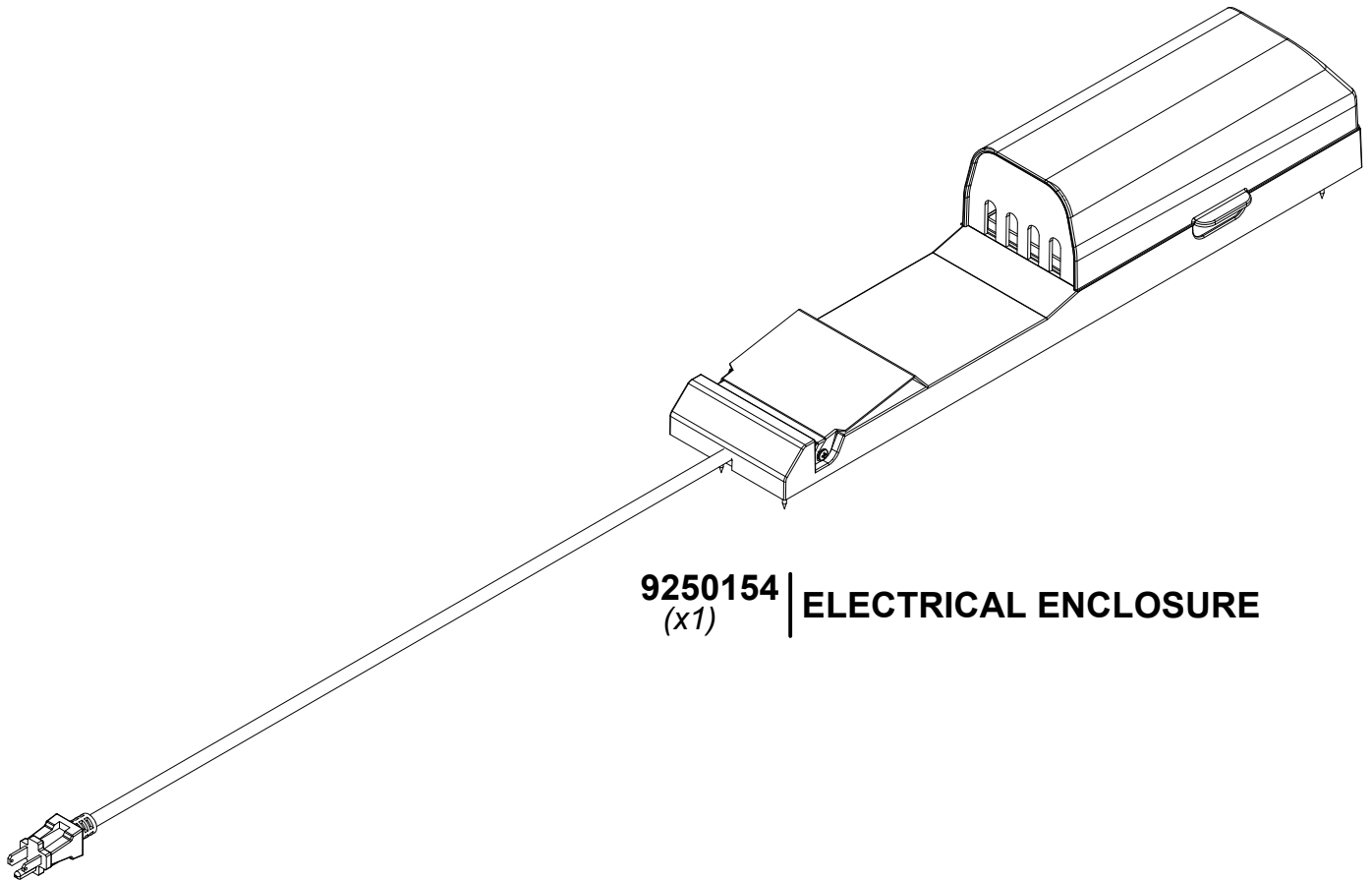

9250154 | **ELECTRICAL ENCLOSURE**
(x1)

FOR POWERPORT INSTALLATION REFER TO ASSEMBLY INSTRUCTIONS THAT COME PACKAGED WITH THE POWERPORT KIT. INSTALL ON ANY EXTERIOR POST THAT IS DESIRED. FOLLOW DIRECTIONS FOR PROPER INSTALLATION.