



Manufactured by:
Backyard Discovery
3305 Airport Drive, Pittsburg, KS 66762
800-856-4445

Basepoint Business Centre: Rivermead Drive, Westlea, Swindon SN5 7EX Phone: 0800-118-2476
J.P. Coenstraat 7, The Bridge, The Hague, 2595 WP, Netherlands Phone: 08005678990

2-4 PERSON HENLEY SLANT ROOF SAUNA

MODEL # : 2504769

THE ASSEMBLY MANUAL MUST BE RETAINED SINCE IT CONTAINS IMPORTANT INFORMATION
LICENSED ELECTRICIAN WORK IS REQUIRED TO INSTALL A DEDICATED 240V/30AMP CIRCUIT



WARNING

Cancer and Reproductive Harm
www.P65Warnings.ca.gov



Please visit www.backyarddiscovery.com

For the most up to date assembly manual, to register your product, or to order replacement parts *Para obtener instrucciones en español, visite*
www.backyarddiscovery.com



EASY STEP-BY-STEP
3D INTERACTIVE INSTRUCTIONS
DOWNLOAD THE FREE APP



OWNER'S MANUAL - BASIC SETUP DIMENSIONS & ASSEMBLY NOTES

CHOOSE A GOOD LOCATION FOR YOUR SAUNA!

It is critically important the sauna foundation is sturdy and level. An unstable foundation can cause the sauna to tilt, shift, or fall, leading to injury.

Pay close attention to the items needed for each step. Make sure you are using the correct hardware for each step.

- Using incorrect hardware may result in improper assembly.
- Ensure the surface is firm and level and can support the weight of the sauna and its users. (1000+ lbs.)
- Many garages, basements or deck floors are sloped for drainage. A slight slope will not be an issue. A more pronounced slope will require shimming to make the sauna level.

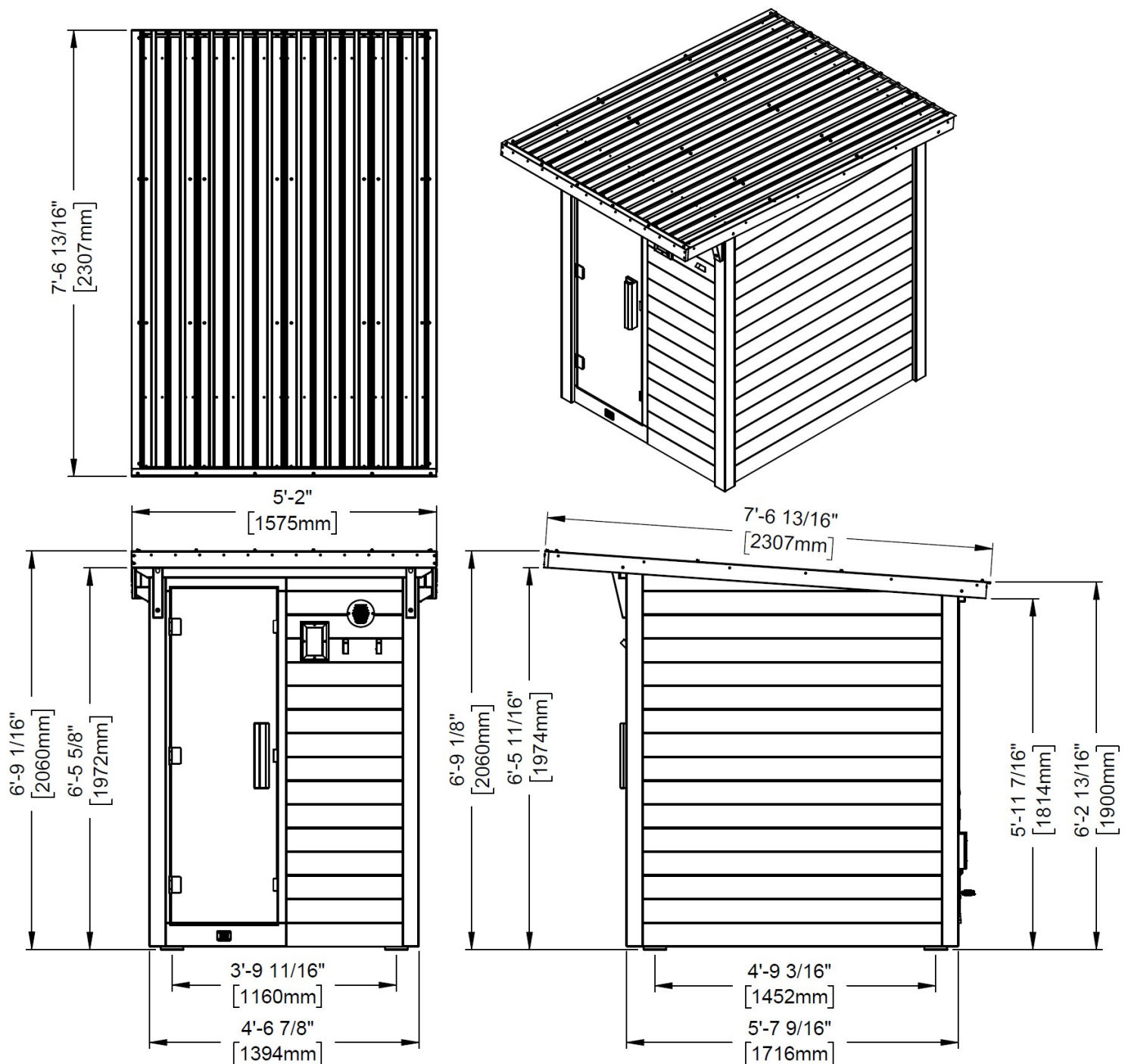

OWNER'S MANUAL - ANCHORING LAYOUT

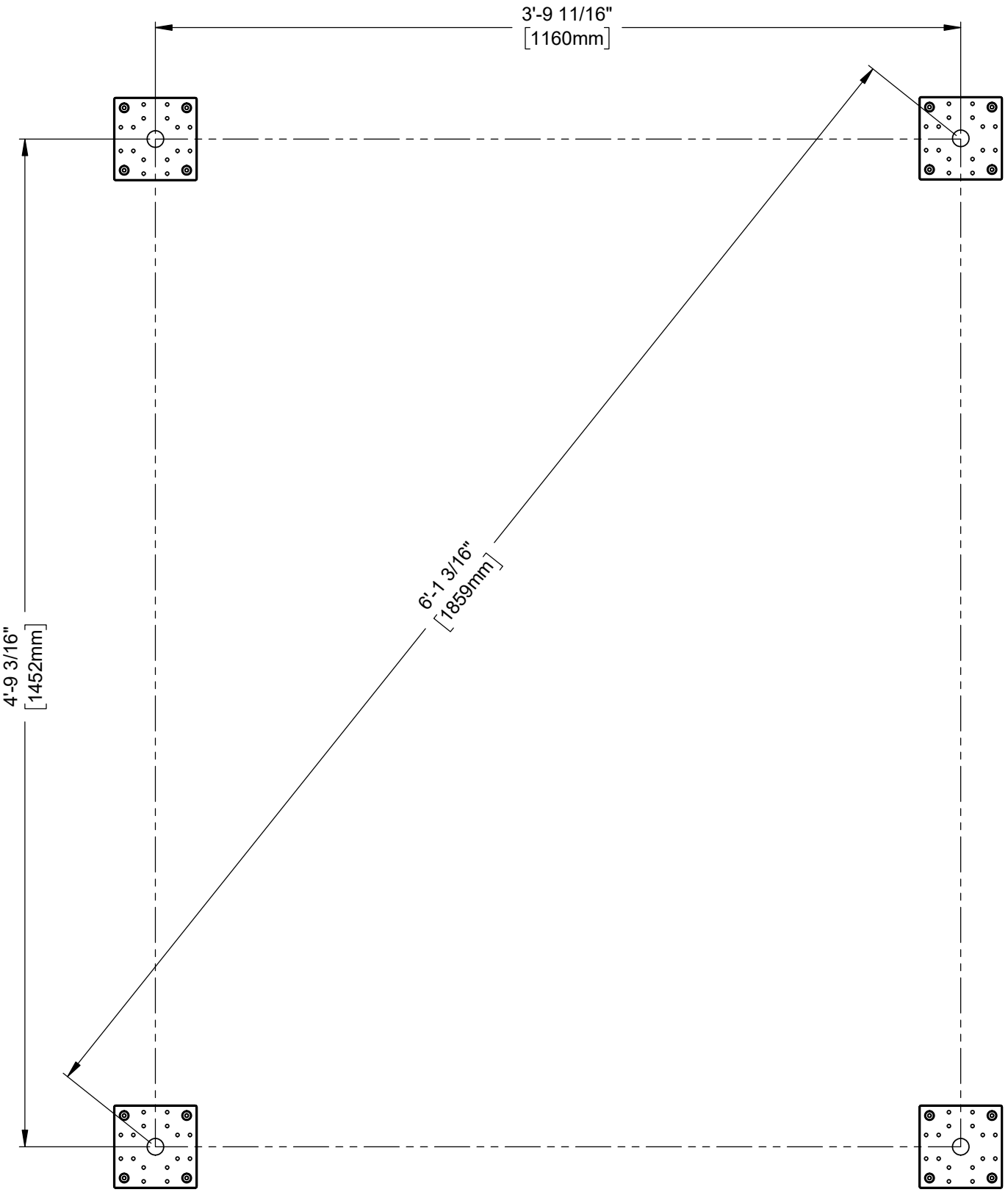

OWNER'S MANUAL - PARTS IDENTIFICATION

WOOD COMPONENTS (NOT TO SCALE)



NG01 FASCIA-W4L22346
(x1) 13/16"x3 3/8"x62" (20X86X1575)



NG04 SLAT-W4L22385
(x3) 13/16"x3 3/8"x50 1/4" (20X86X1276)

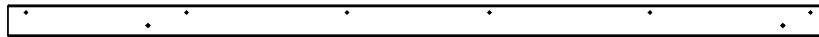

NG02 ROOF TRIM-W4L22360
(x2) 13/16"x3 3/8"x89 3/8" (20X86X2270)



NG03 FASCIA-W4L22362
(x1) 13/16"x3 1/8"x60 3/8" (20X80X1534)

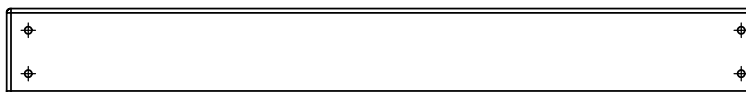

NR03 HEATER GUARD BOARD-W4L22036
(x5) 13/16"x2 3/8"x20 3/8" (20X60X518)

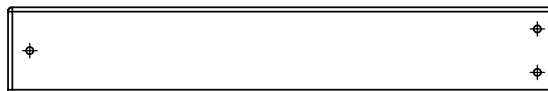

NR04 HEATER GUARD BOARD-W4L22037
(x5) 13/16"x2 3/8"x15" (20X60X381)

OWNER'S MANUAL - PARTS IDENTIFICATION

WOOD COMPONENTS (NOT TO SCALE)



OG01 FLOOR JOIST-W4L22363
(x1) 1 3/16"x3 3/8"x63 1/16" (30X86X1602)



OG02 FLOOR JOIST-W4L22367
(x1) 1 3/16"x3 3/8"x48 1/16" (30X86X1220)

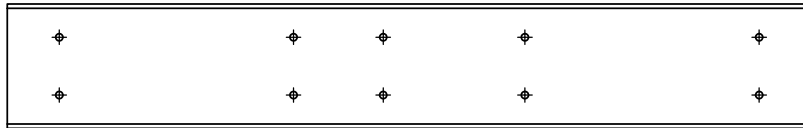

OG03 FLOOR JOIST-W4L22368
(x1) 1 3/16"x3 3/8"x21 7/8" (30X86X556)



OG04 FLOOR JOIST-W4L22369
(x1) 1 3/16"x3 3/8"x48 1/16" (30X86X1220)



OG05 FLOOR JOIST-W4L22372
(x1) 1 3/16"x3 3/8"x61 7/8" (30X86X1572)



OG06 FLOOR JOIST-W4L22380
(x1) 1 3/16"x3 3/8"x48 1/16" (30X86X1220)

OWNER'S MANUAL - PARTS IDENTIFICATION

WOOD COMPONENTS (NOT TO SCALE)

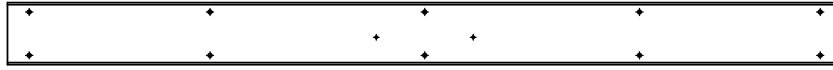

OG07 SEAT CLEAT-W4L22382
(x1) 1 3/16"x3 3/8"x45 7/16" (30X86X1154)

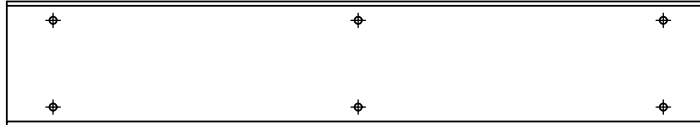

OG08 SEAT CLEAT-W4L22384
(x2) 1 3/16"x3 3/8"x19 1/8" (30X86X486)

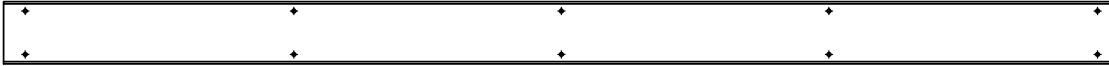

OG10 WIREWAY BOARD-W4L22387
(x1) 1 3/16"x3 3/8"x60 3/4" (30X86X1543)



OG11 WIREWAY BOARD-W4L22388
(x1) 1 3/16"x3 3/8"x10 1/2" (30X86X266)

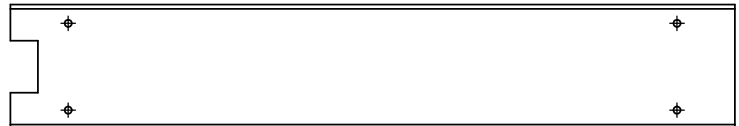

OG12 WIREWAY BOARD-W4L22389
(x1) 1 3/16"x3 3/8"x19 3/4" (30X86X501)



OG13 LIGHT MOUNT-W4L22391
(x1) 30x3 3/8"x35 7/16" (30X86X900)



OG14 WIREWAY BOARD-W4L22393
(x1) 1 3/16"x3 3/8"x53 9/16" (30X86X1360)

OWNER'S MANUAL - PARTS IDENTIFICATION

WOOD COMPONENTS (NOT TO SCALE)

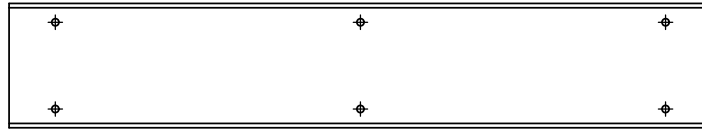

OG15 SEAT CLEAT-W4L22407
(x2) 1 3/16"x3 3/8"x19 1/8" (30X86X486)



OJ01 WALL BOARD-W4L22347
(x1) 1 3/16"x5 1/4"x63 1/16" (30X134X1602)



OJ01 WALL BOARD-W4L22347
(x1) 1 3/16"x5 1/4"x63 1/16" (30X134X1602)

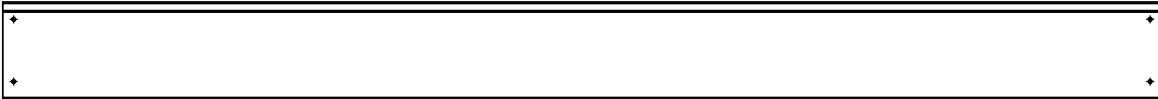

OJ02 WALL BOARD-W4L22348
(x14) 1 3/16"x5 1/4"x63 1/16" (30X134X1602)



OJ02 WALL BOARD-W4L22348
(x14) 1 3/16"x5 1/4"x63 1/16" (30X134X1602)



OJ03 WALL BOARD-W4L22349
(x1) 1 3/16"x5 1/4"x50 3/8" (30X134X1280)



OJ04 WALL BOARD-W4L22350
(x9) 1 3/16"x5 1/4"x50 3/8" (30X134X1280)

OWNER'S MANUAL - PARTS IDENTIFICATION

WOOD COMPONENTS (NOT TO SCALE)



OJ05 WALL BOARD-W4L22351
(x11) 1 3/16"x5 1/4"x24 3/4" (30X134X629)

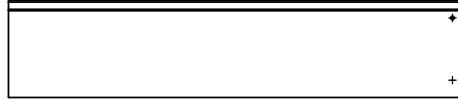

OJ06 WALL BOARD-W4L22352
(x1) 1 3/16"x5 1/4"x24 3/4" (30X134X629)



OJ07 WALL BOARD-W4L22353
(x1) 1 3/16"x5 1/4"x24 3/4" (30X134X629)



OJ08 WALL BOARD-W4L22354
(x1) 1 3/16"x5 1/4"x50 3/8" (30X134X1280)



OJ09 WALL BOARD-W4L22357
(x1) 1 3/16"x5 1/4"x63 1/16" (30X134X1602)



OJ09 WALL BOARD-W4L22357
(x1) 1 3/16"x5 1/4"x63 1/16" (30X134X1602)

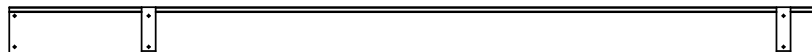

OJ10 ROOF BOARD-W4L22359
(x12) 1 3/16"x5 1/4"x88 9/16" (30X134X2250)

OWNER'S MANUAL - PARTS IDENTIFICATION

WOOD COMPONENTS (NOT TO SCALE)

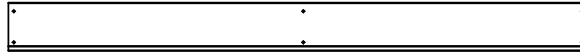

OJ11 FLOOR BOARD-W4L22374
(x3) 1 3/16"x5 1/4"x63 1/16" (30X134X1602)

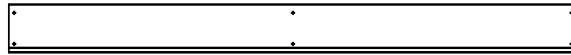

OJ12 FLOOR BOARD-W4L22376
(x4) 1 3/16"x5 1/4"x61 7/8" (30X134X1572)



OJ13 FLOOR BOARD-W4L22377
(x1) 1 3/16"x5 1/4"x63 1/16" (30X134X1602)



OJ14 FLOOR BOARD-W4L22379
(x1) 1 3/16"x5 1/4"x61 7/8" (30X30X1572)



OJ15 WALL BOARD-W4L22390
(x1) 1 3/16"x5 1/4"x50 3/8" (30X134X1280)

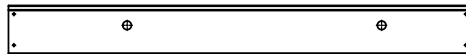

OJ16 WALL BOARD-W4L22392
(x1) 1 3/16"x5 1/4"x50 3/8" (30X134X1280)

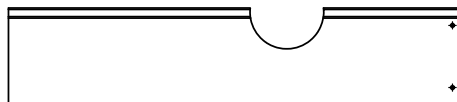

OJ17 WALL BOARD-W4L22394
(x1) 1 3/16"x5 1/4"x24 3/4" (30X134X629)

OWNER'S MANUAL - PARTS IDENTIFICATION

WOOD COMPONENTS (NOT TO SCALE)

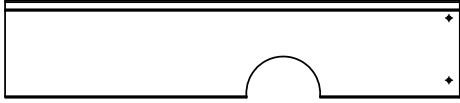

OJ18 WALL BOARD-W4L22395
(x1) 1 3/16"x5 1/4"x24 3/4" (30X134X629)



OJ19 WALL BOARD-W4L22396
(x1) 1 3/16"x5 1/4"x50 3/8" (30X134X1280)



OJ20 WALL BOARD-W4L22397
(x1) 1 3/16"x5 1/4"x50 3/8" (30X134X1280)

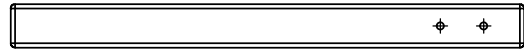

OO01 SLAT CLEAT-W4L22404
(x2) 1 3/16"x1 3/16"x14" (30X30X355)

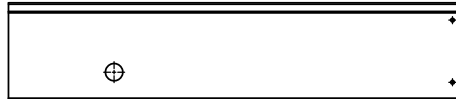

OJ21 WALL BOARD-W4L22408
(x1) 1 3/16"x5 1/4"x24 3/4" (30X134X629)



OO02 FLOOR TRIM-W4L22365
(x1) 1 3/16"x1 3/16"x63 1/16" (30X30X1602)

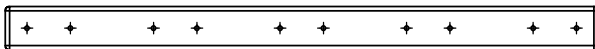

OO03 HEATER GUARD BOARD-W4L22038
(x2) 1 3/16"x1 3/16"x16 1/8" (30X30X410)

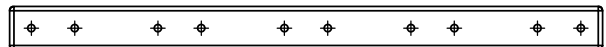

OO04 HEATER GUARD BOARD-W4L22035
(x1) 1 3/16"x1 3/16"x16 1/8" (30X30X410)

OWNER'S MANUAL - PARTS IDENTIFICATION

WOOD COMPONENTS (NOT TO SCALE)



OO05 FLOOR TRIM-W4L22366
(x1) 1 3/16"x1 3/16"x48 1/16" (30X30X1220)



OO06 FLOOR TRIM-W4L22373
(x1) 1 3/16"x1 3/16"x61 7/8" (30X30X1572)

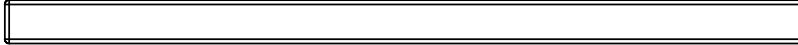

OO07 FLOOR TRIM-W4L22378
(x1) 1 3/16"x1 3/16"x21 13/16" (30X30X554)



OO08 ROOF TRIM-W4L22398
(x1) 1 3/16"x1 3/16"x60 7/16" (30X30X1535)

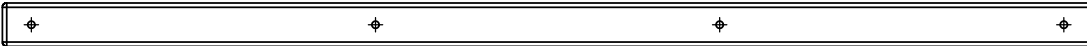

OO09 TRIM-W4L22400
(x2) 1 3/16"x1 3/16"x29 11/16" (30X30X754)

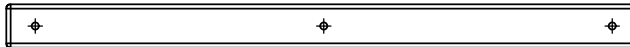

OO10 TRIM-W4L22401
(x2) 1 3/16"x1 3/16"x17 5/16" (30X30X439)



OO11 TRIM-W4L22402
(x2) 1 3/16"x1 3/16"x59 13/16" (30X30X1519)

OWNER'S MANUAL - PARTS IDENTIFICATION

WOOD COMPONENTS (NOT TO SCALE)

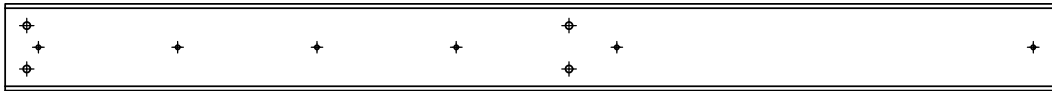

OR01 SEAT UPRIGHT-W4L22406
(x2) 1 3/16"x2 3/8"x28 3/4" (30X60X730)



OR02 ANGLE BRACE-W4L21946
(x4) 1 3/16"x2 3/8"x10 7/8" (30X60X276)

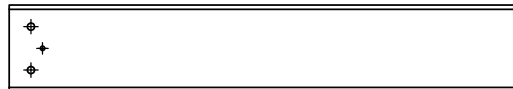

OR03 BENCH UPRIGHT-W4L22405
(x2) 1 3/16"x2 3/8"x14" (30X60X355)



OR04 ROOF BOARD-W4L22359
(x1) 1 3/16"x1 1/2"x88 9/16" (30X38X2250)



OR05 ROOF BOARD-W4L22359
(x1) 1 3/16"x1 1/2"x88 9/16" (30X38X2250)



OS01 FLOOR BOARD-W4L22364
(x1) 1 3/16"x3 11/16"x63 1/16" (30X94X1602)



OS02 FLOOR BOARD-W4L22375
(x1) 1 3/16"x3 11/16"x61 7/8" (30X94X1572)

OWNER'S MANUAL - PARTS IDENTIFICATION

WOOD COMPONENTS (NOT TO SCALE)



SP01 POST-W4L22341
(x1) 3 3/8"x3 3/8"x77 13/16" (86X86X1976)

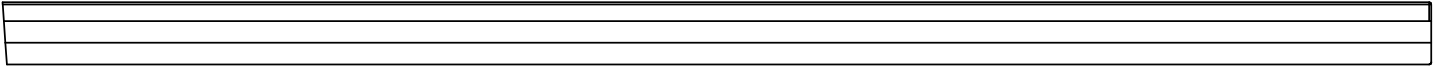

SP02 POST-W4L22342
(x1) 3 3/8"x3 3/8"x77 13/16" (86X86X1976)

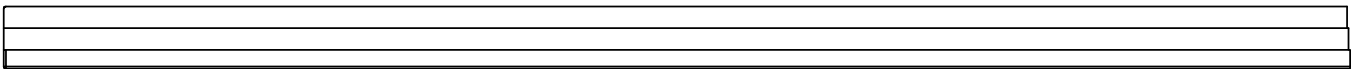

SP03 POST-W4L22343
(x1) 3 3/8"x3 3/8"x73 1/16" (86X86X1856)

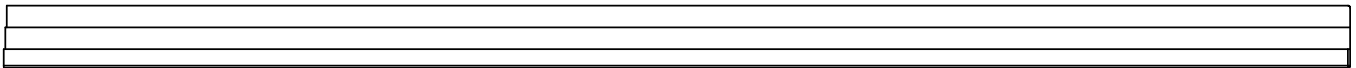

SP04 POST-W4L22344
(x1) 3 3/8"x3 3/8"x74 1/4" (86X86X1886)



W01 SEAT TRIM-W4L22383
(x2) 1 9/16"x3 3/8"x50 1/4" (40X86X1276)



W02 FOOT BRACE-W4L22399
(x4) 1 15/16"x3 3/8"x10 1/4" (50X86X261)

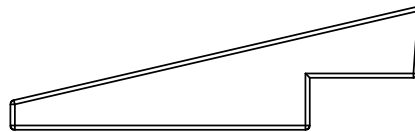

W03 ANGLE BRACE-W4L22409
(x2) 1 15/16"x3 3/8"x11 1/4" (50X86X285)

OWNER'S MANUAL - PARTS IDENTIFICATION

WOOD COMPONENTS (NOT TO SCALE)

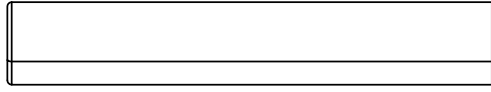

AM02 DOOR HANDLE-W4L22361
(x1) 2 1/4"x3"x13 5/16" (57X76X338)



E01 TRIM BOARD-W4L22345
(x2) 1 7/16"x3 3/8"x60 3/8" (36X86X1534)



HB01 WALL BOARD-W4L22356
(x2) 15/16"x2 3/4"x48 1/16" (24X70X1220)

OWNER'S MANUAL - PARTS IDENTIFICATION

WOOD COMPONENTS (NOT TO SCALE)

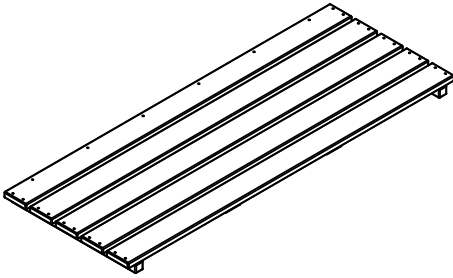

BA01 BENCH ASSEMBLY-W2A04918
(x1) 1 15/16"x19 1/8"x50 1/4" (50X486X1276)

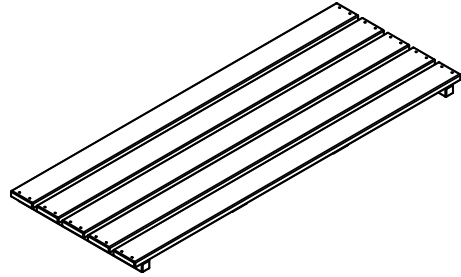

BA02 BENCH ASSEMBLY-W2A04920
(x1) 1 15/16"x19 1/8"x50 1/4" (50X486X1276)

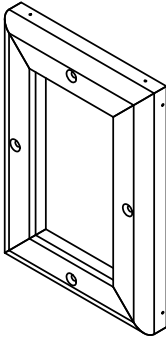

TF01 TRIM FRAME-W2A04797
(x1) 7/8"x5 9/16"x8 1/16" (22X142X204)



AM01 DOOR HANDLE-W2A04917
(x1) 2 1/4"x3"x13 5/16" (57X76X338)

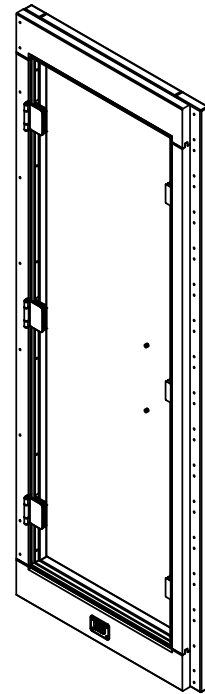

WP01 DOOR WALL PANEL ASSEMBLY-W2A04911
(x1) 2 3/8"x27 1/4"x77 5/8" (60X692X1972)

OWNER'S MANUAL - PARTS IDENTIFICATION

ACCESSORY COMPONENTS (NOT TO SCALE)

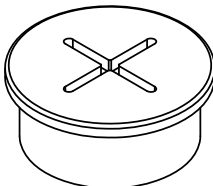

1467 25mm SILICONE GROMMET-A6P01467
(x4)

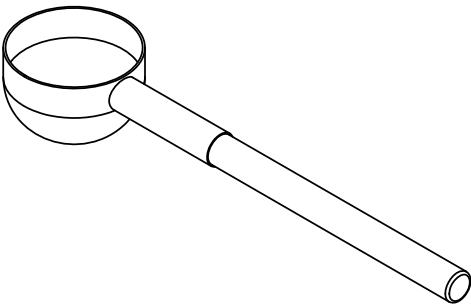

L01 LADLE-A4M05596
(x1)

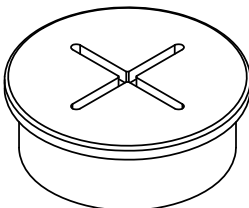

1468 30mm SILICONE GROMMET-A6P01468
(x1)

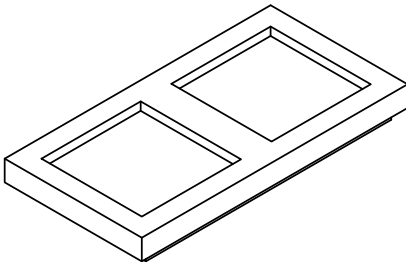

T01 THERMOMETER-W4L21965
(x1)

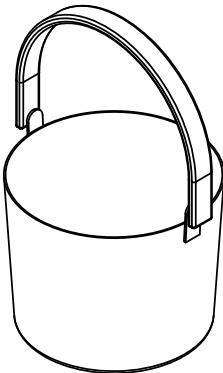

B01 BUCKET-A4M05673
(x1)

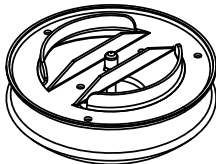

5992 VENT ASSEMBLY-A4M05592
(x1)

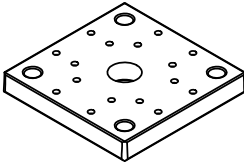

0500 PLASTIC POST FOOT-A6P00500
(x4)

OWNER'S MANUAL - PARTS IDENTIFICATION

ACCESSORY COMPONENTS (NOT TO SCALE)

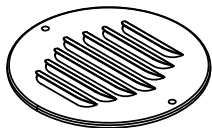

5285 VENT-A4M05285
(x2)

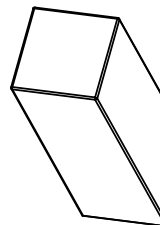

5672 GARMENT HANGER ASSEMBLY-A4M05672
(x2)

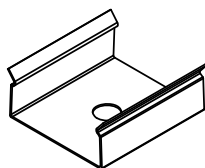

1493-04 LIGHT CLIP-A6P01493-04
(x4)

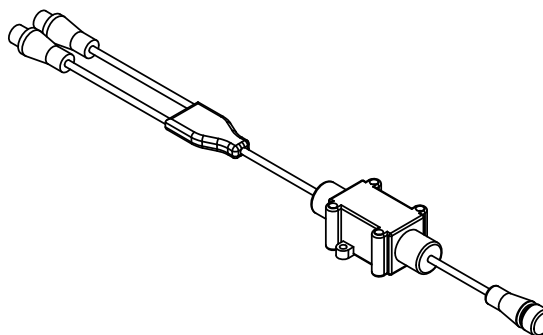

1493-01 REMOTE MODULE-A6P01493-01
(x1)

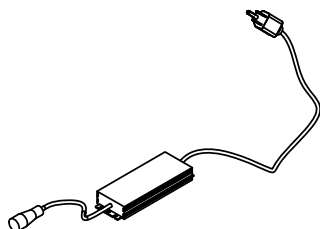

1493-03 LED POWER SUPPLY-A6P01493-03
(x1)

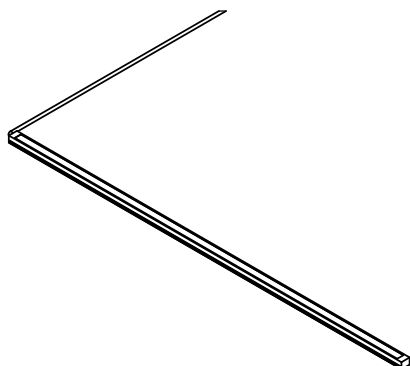

1493-02 LED LIGHT-A6P01493-02
(x2)

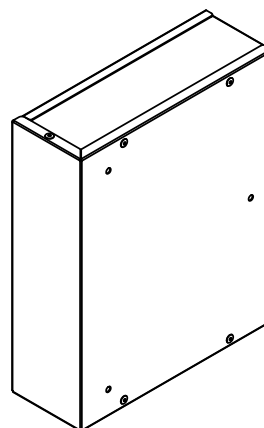

5590-01 SERVICE PANEL-A4M05590-01
(x1)

OWNER'S MANUAL - PARTS IDENTIFICATION

ACCESSORY COMPONENTS (NOT TO SCALE)

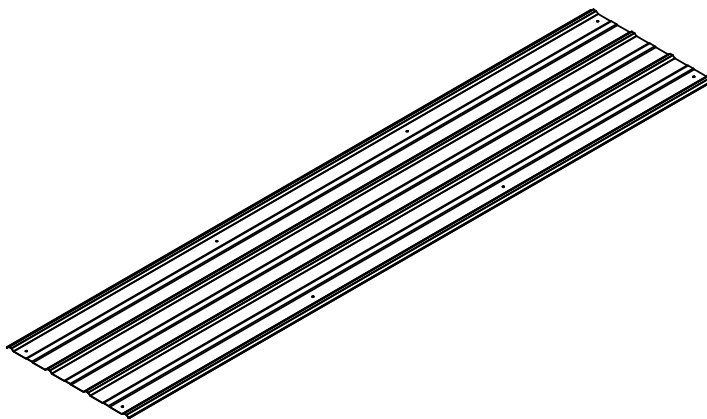

5912 29GA SHEETING-A4M05912
(x2) 1/4"x18 7/8"x90 1/16" (7X480X2287)

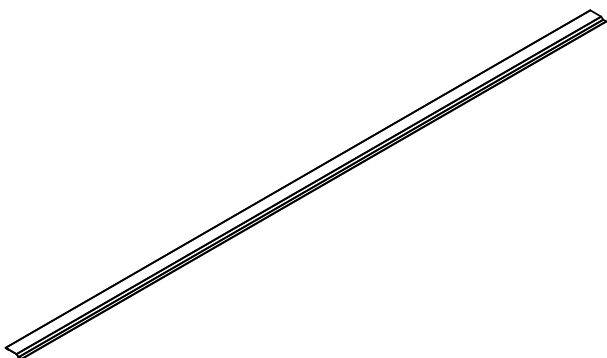

5914 EDGE TRIM-A4M05914
(x2) 1/32"x3 3/8"x90 1/16" (0.5X85X2287)

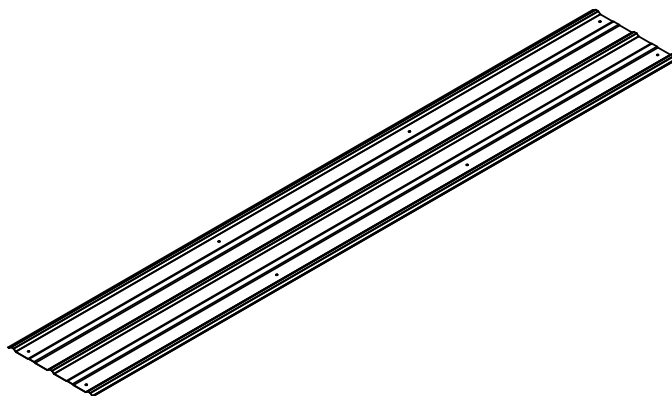

5913 29GA SHEETING-A4M05913
(x2) 1/4"x13 1/16"x90 1/16" (7X332X2287)

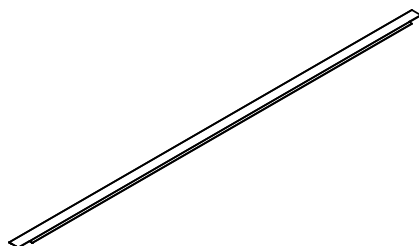

5915 EDGE TRIM-A4M05915
(x1) 1/32"x2 9/16"x62" (0.50X66X1575)

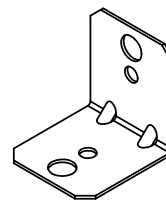

555 L BRACKET BLK-A4M00555
(x8) 1 1/4"x1 3/8"x1 3/8" (32X35X35)

OWNER'S MANUAL - PARTS IDENTIFICATION

ACCESSORY COMPONENTS (NOT TO SCALE)

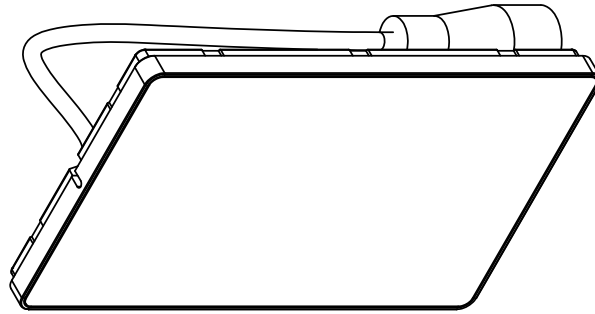

5590-02 CONTROL PANEL-A4M05590-02
(x1)

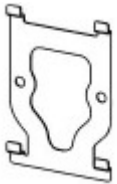

5590-02 CONTROL PANEL MOUNTING
BRACKET-A4M05590-03 (x1)



1490 SAUNA POWER WIRE-A6P01490
(x1)



5590-10 WIRING HARNESS-A4M05590-10
(x1)

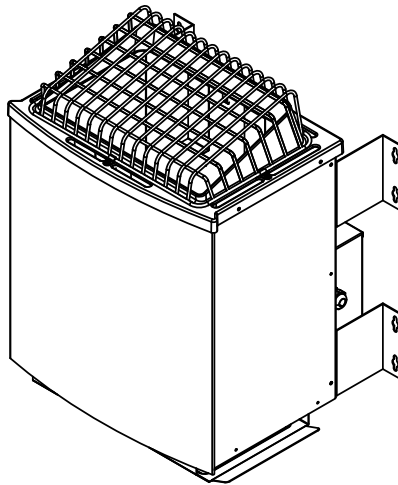

0253 9KW ELECTRIC SAUNA HEATER-9250253
(x1)

OWNER'S MANUAL - PARTS IDENTIFICATION

HARDWARE COMPONENTS (TO SCALE)



H101193 TORX PAN HEAD
(x4) 1/4-20x1/2 SS

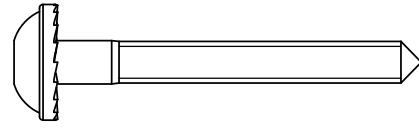

H100487 LAG SCREW WH BLK
(x1) 1/4x2

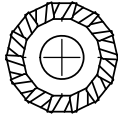

H100405 WASHER LOCK EXT BLK
(x1) 6x15

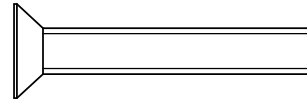

H101402 SCREW TFH
(x2) 1/4-20 X 1 5/8 SS

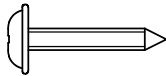

H100392 SCREW PWH BLK
(x2) 8x3/4

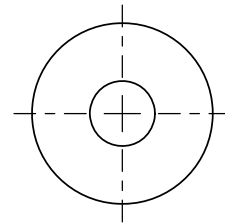

H101403 POLY WASHER
(x4)

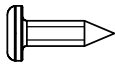

H101409 SCREW PPH 4x1/2 BLK
(x9) 4x1/2

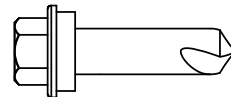

H101116 SCREW SELF TAPPING 1/4x1 BLK
(x8) 1/4 x 1

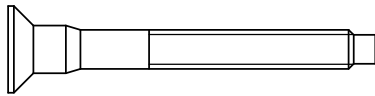

H101030 SCREW CONFIRMAT BLK
(x8) 7x2

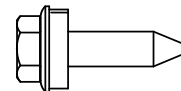

H101117 SCREW WOODGRIP
(x38) 10x3/4



H100114 TORX WRENCH
(x8)

OWNER'S MANUAL - PARTS IDENTIFICATION

HARDWARE COMPONENTS (TO SCALE)

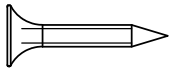

H100885 SCREW TFH BLK
(x4) 8x7/8

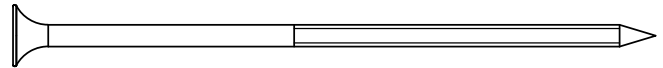

H101435 SCREW TFH 8X3 1/2 SS-BLK
(x6) 8x3 1/2

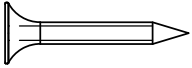

H101424 SCREW TFH 8X1 SS-BLK
(x4) 8x1

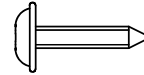

H101437 SCREW TWH 8x5/8 SS-BLK
(x4) 8x5/8

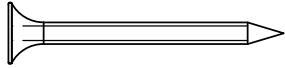

H101427 SCREW TFH 8X1 1/2 SS-BLK
(x16) 8x1-1/2

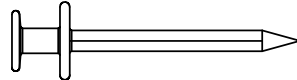

H101468 SCREW RAISED HEAD 8x1
(x8) 8x1

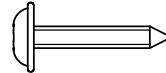

H101438 SCREW TWH 8x3/4 SS-BLK
(x20) 8x3/4

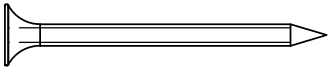

H101428 SCREW TFH 8X1 3/4 SS-BLK
(x119) 8x1-3/4

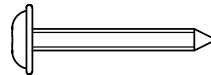

H101440 SCREW TWH 8x1 SS-BLK
(x11) 8x1

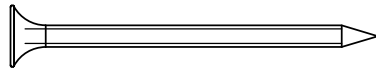

H101429 SCREW TFH 8X2 SS-BLK
(x650) 8x2

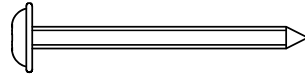

H101443 SCREW TWH 8x1 1/2 SS-BLK
(x16) 8x1-1/2

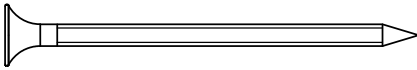

H101430 SCREW TFH 8X2 1/4 SS-BLK
(x12) 8x2-1/4

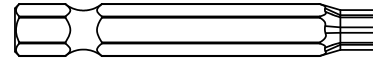

H100879 TORX BIT
(x1) T-20

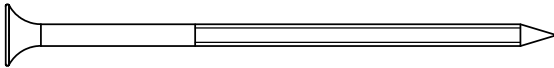

H101433 SCREW TFH 8X3 SS-BLK
(x10) 8x3

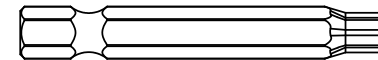

H100147 TORX BIT
(x1) T-30

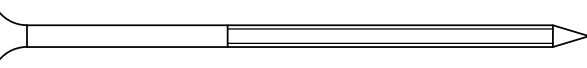

H101434 SCREW TFH 8X3 1/4 SS-BLK
(x2) 8x3 1/4

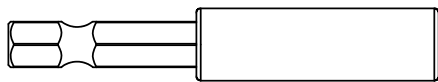

H101100 MAGNETIC DRIVER
(x1)

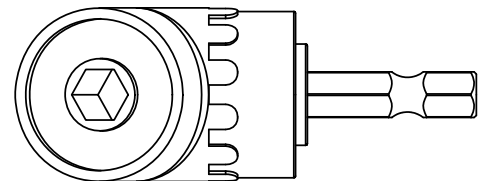

H101114 RIGHT ANGLE DRILL ADAPTER
(x1)

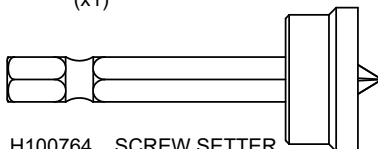

H100764 SCREW SETTER
(x1)

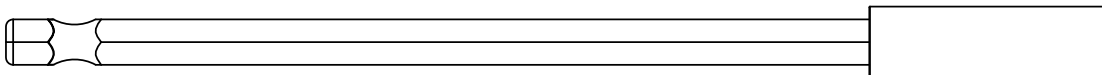

H101278 6" MAGNETIC DRIVER EXTENSION
(x1)

PRE-ASSEMBLY STEP 1 - SORTING PARTS

It is critical for ease of assembly that you take the time to sort and organize the wood and hardware.

WOOD PARTS:

- Organize wood parts by the three-digit, alpha-numeric number stamped on each board (ex. P01).
- If there are multiple boards with the same stamped number, stack those pieces together.
- Stamps can be found on the flat surface of the boards or on the end of the boards.
- Allow yourself plenty of room - the wood pieces can take up a significant amount of space.

NOTE: CARTONS ARE NOT ORGANIZED BY BOARD NUMBER.



HARDWARE PARTS:

- We recommend that you have a separate table to organize the hardware.
- Hardware bags are printed with a seven-digit, alpha-numeric part number.
- You can organize your hardware by part number or group by hardware type (i.e. bolts, nuts, etc.).
- During assembly you only need to reference the last four digits of the number.

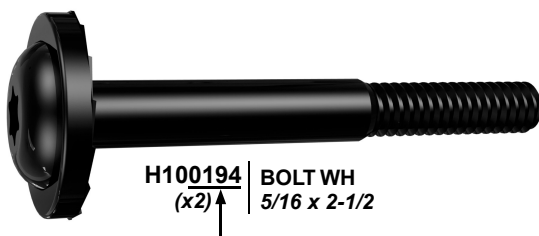

H100194 | BOLT WH
(x2) ↑ 5/16 x 2-1/2

PRE-ASSEMBLY STEP 2 - TOOLS REQUIRED



Cordless Drill or
Electric Drill



Drill Attachments:
Phillips Head



1/8", 3/16", 3/8" &
7/16" Drill Bits



Phillips Screw Driver

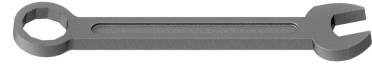

Open End
Wrenches 1/2" &
7/16"



3/8" Drive Ratchet, 1/2" &
7/16" STD Sockets, 1/2" &
7/16" Deep Sockets



Tape Measure



Claw Hammer

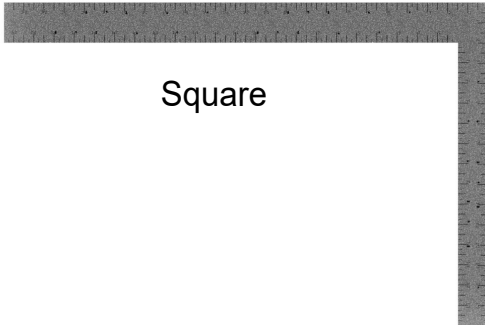

Square



Level 24"

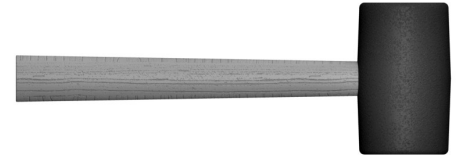

Rubber Mallet -
Optional

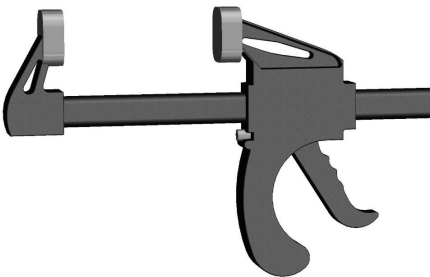

A6P00460 | QUICK RELEASE
(2) BAR CLAMP

PRE-ASSEMBLY STEP 3 - CHOOSE YOUR ASSEMBLY METHOD

There are several types of assembly instructions available to you.

1. Printed Assembly Manual included with your set
2. BILT APP - 3D interactive instructions
3. Combination of the Printed Manual and BILT APP (Note: Step numbers can differ between the two methods)



The advertisement features the BILT logo (a hexagon with a white dot inside) and the word "BILT." in a bold, sans-serif font. To the right, a QR code is labeled "SCAN FOR BILT 3D INSTRUCTIONS". Below the QR code, it says "POWERED BY BILT INTELLIGENT INSTRUCTIONS®". Two buttons are present: "Download on the App Store" and "GET IT ON Google Play". The central text reads "Scan for easy 3D instructions" followed by "Download the BILT app before you begin". At the bottom, a smartphone screen displays a 3D assembly instruction for step 17, showing a metal frame with a horizontal bar and several hanging components. The screen includes a "Hardware Needed" button, a close button (X), a menu button (three dots), a volume icon, and navigation arrows.

STEP 1 - FLOOR ASSEMBLY

QTY	PART NUMBER	DESCRIPTION
2	H101429	SCREW TFH 8X2 SS-BLK



OG04 FLOOR JOIST - W4L22369
 (x1) 1 3/16"x3 3/8"x48 1/16" (30x86x1220)

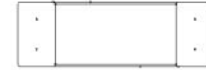

W02 FOOT BRACE - W4L22399
 (x1) 1 15/16"x3 3/8"x10 1/4" (50x86x261)

- ALIGN PILOT HOLES.

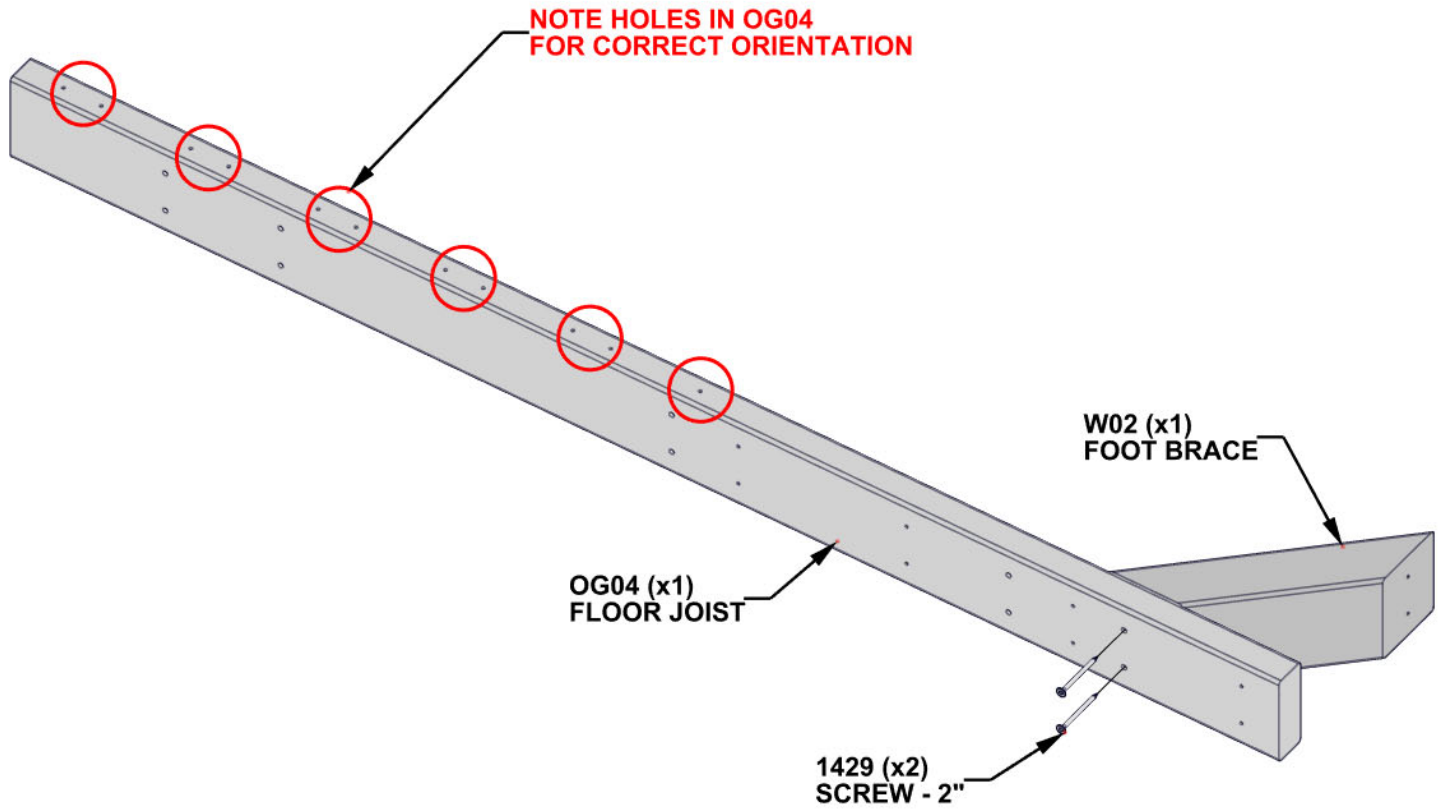

STEP 2 - FLOOR ASSEMBLY

QTY	PART NUMBER	DESCRIPTION
8	H101429	SCREW TFH 8X2 SS-BLK

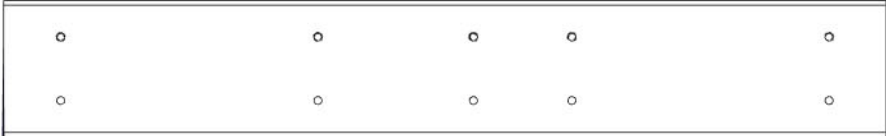

OG03 FLOOR JOIST - W4L22368
(x1) 1 3/16"x3 3/8"x21 7/8" (30x86x556)

- ALIGN PILOT HOLES.

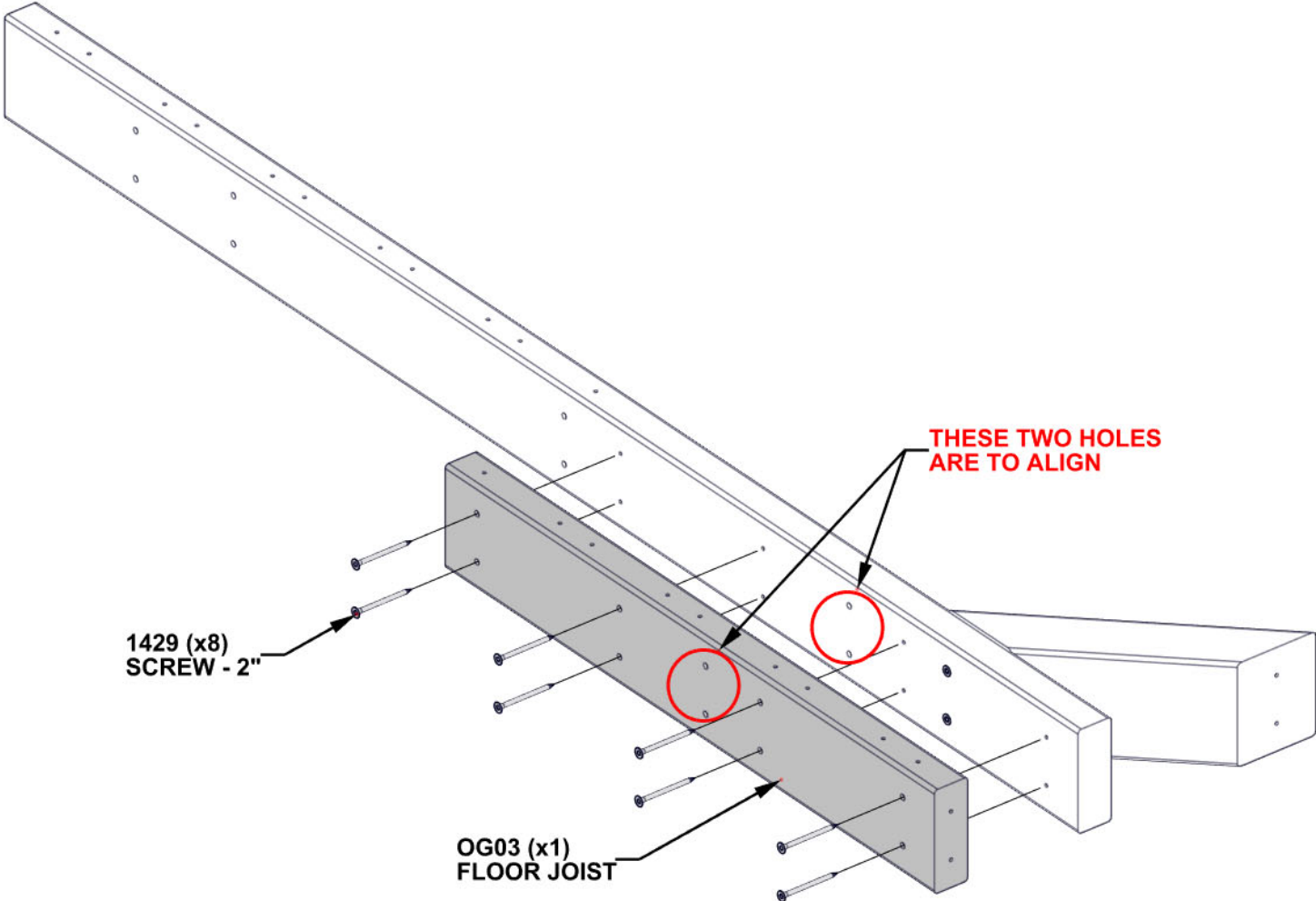

STEP 3 - FLOOR ASSEMBLY

QTY	PART NUMBER	DESCRIPTION
6	H101429	SCREW TFH 8X2 SS-BLK



OG01 FLOOR JOIST - W4L22363
(x1) 1 3/16"x3 3/8"x63 1/16" (30x86x1602)



OG02 FLOOR JOIST - W4L22367
(x1) 1 3/16"x3 3/8"x48 1/16" (30x86x1220)

- HAND TIGHTEN ONLY.
- ALIGN PILOT HOLES.

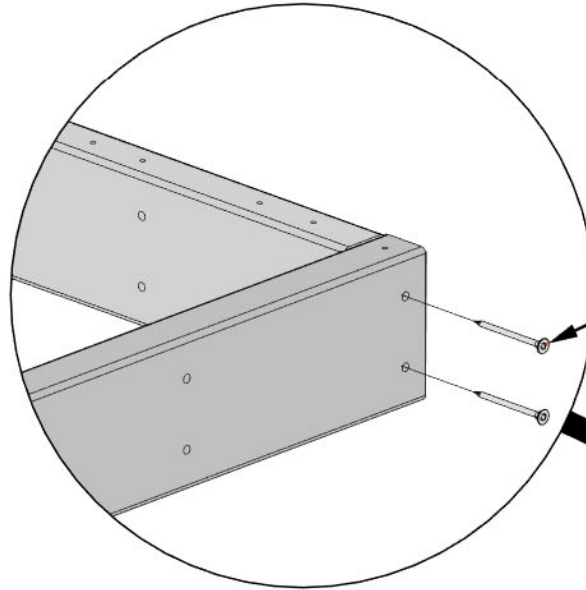

1429 (x6)
SCREW - 2"

OG02 (x1)
FLOOR JOIST

OG01 (x1)
FLOOR JOIST

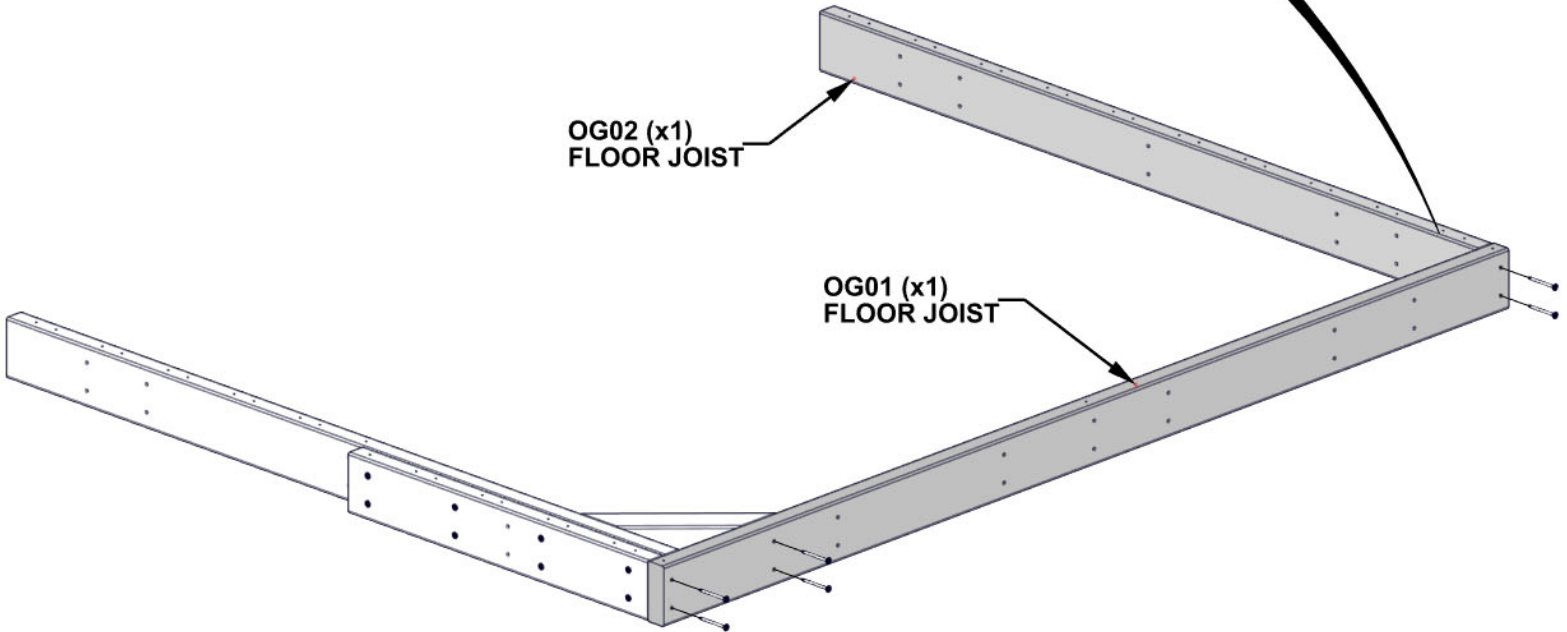

STEP 4 - FLOOR ASSEMBLY

QTY	PART NUMBER	DESCRIPTION
8	H101429	SCREW TFH 8X2 SS-BLK



OG05 FLOOR JOIST - W4L22372
(x1) 1 3/16"x3 3/8"x61 7/8" (30x86x1572)



OG06 FLOOR JOIST - W4L22380
(x1) 1 3/16"x3 3/8"x48 1/16" (30x86x1220)

- SQUARE FLOOR JOIST AND TIGHTEN HARDWARE.
- **ALIGN PILOT HOLES.**

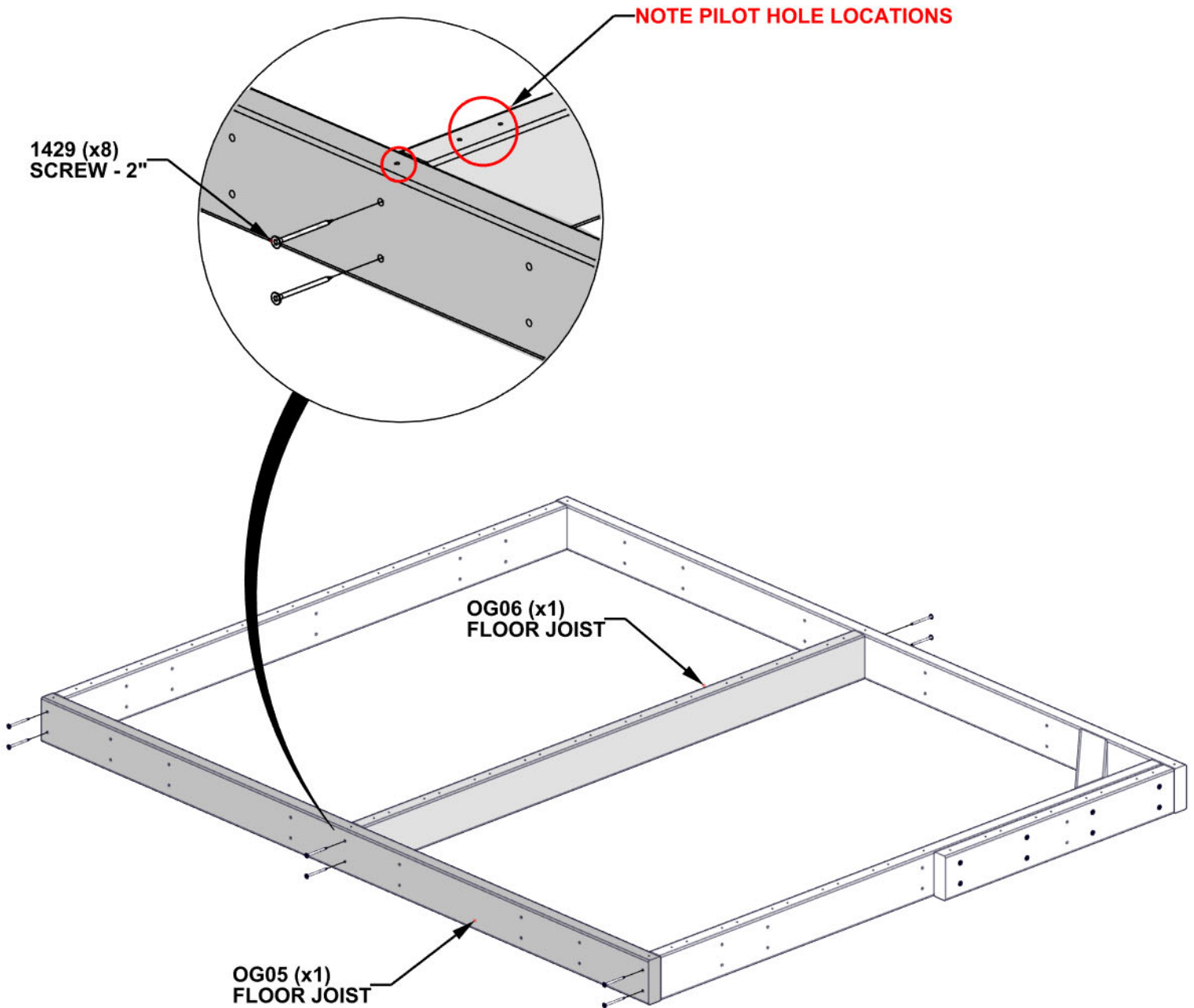

STEP 5 - FLOOR ASSEMBLY

QTY	PART NUMBER	DESCRIPTION
12	H101429	SCREW TFH 8X2 SS-BLK



W02 FOOT BRACE - W4L22399
(x3) 1 15/16"x3 3/8"x10 1/4" (50x86x261)

- ALIGN PILOT HOLES.

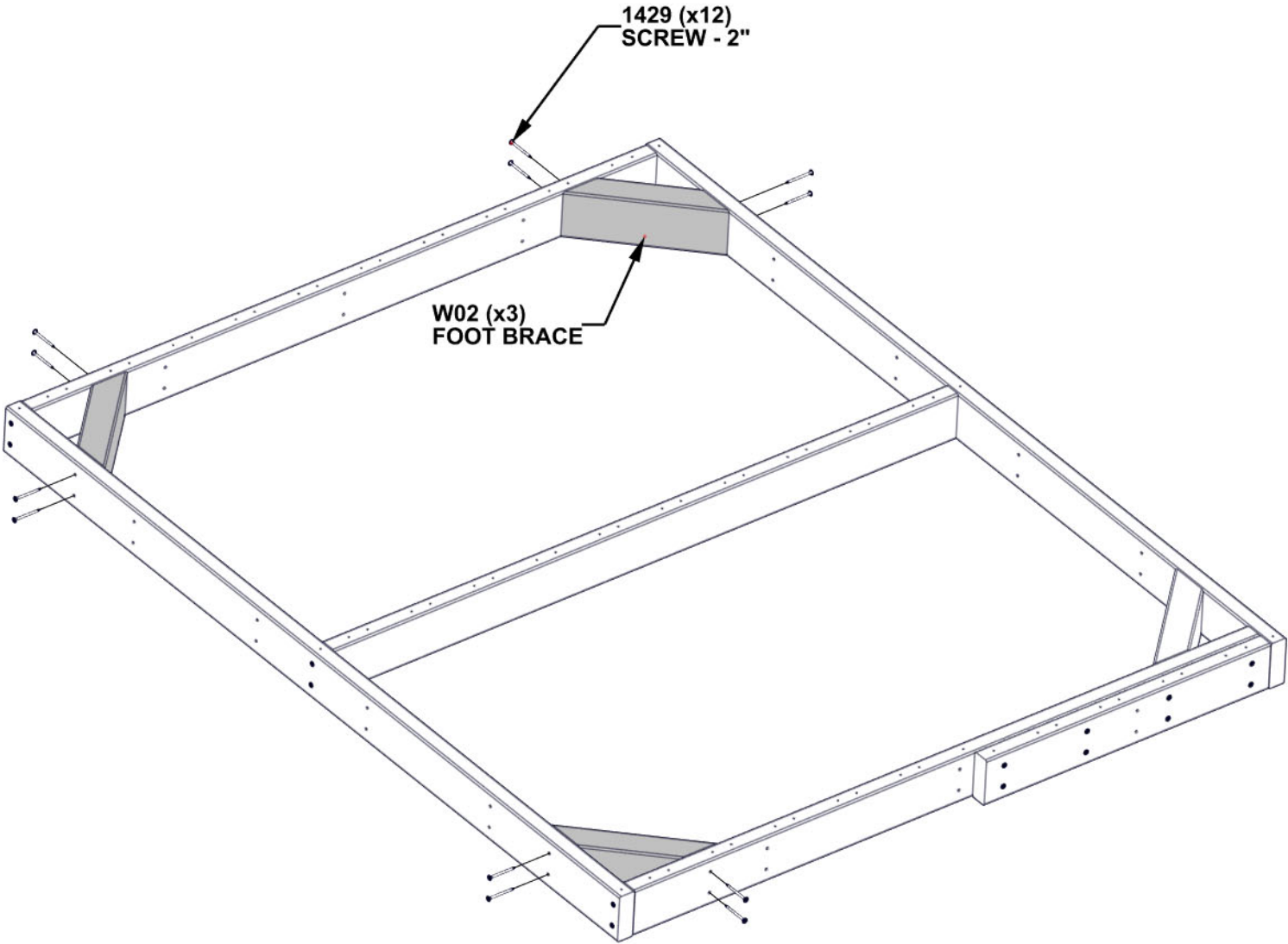

STEP 6 - FLOOR ASSEMBLY

QTY	PART NUMBER	DESCRIPTION
16	H101427	SCREW TFH 8X1 1/2 SS-BLK

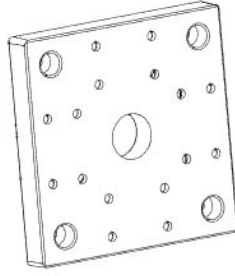

A6P00500 PLASTIC POST FOOT
(x4)

- FLIP ASSEMBLY OVER AND ATTACH FEET AS SHOWN.
- ALIGN FEET AS SHOWN AND DRILL A 1/8" [3mm] PILOT HOLES FOR THE ATTACHMENT OF HARDWARE.

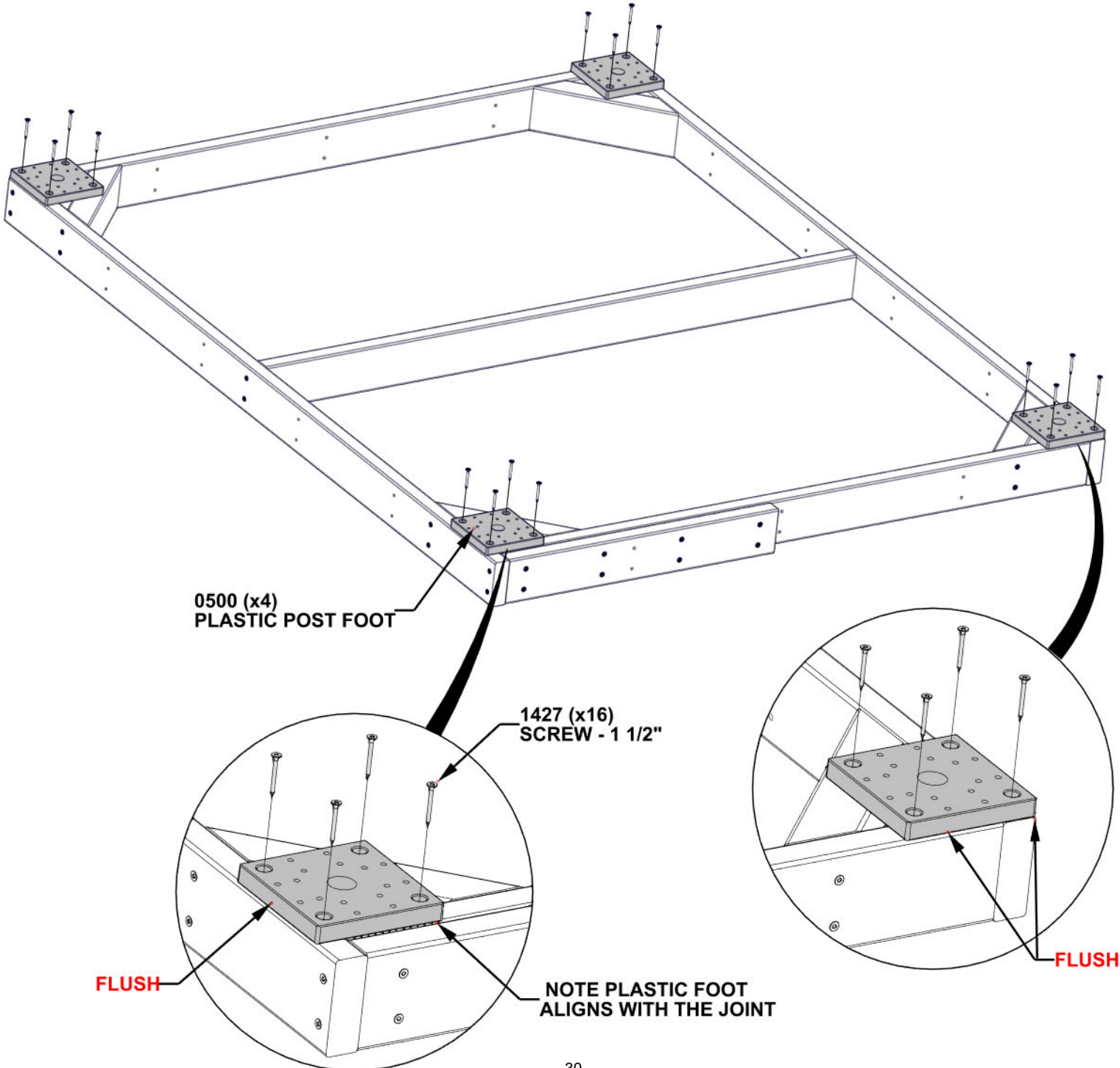

STEP 7 - LEFT WALL ASSEMBLY

QTY	PART NUMBER	DESCRIPTION
63	H101429	SCREW TFH 8X2 SS-BLK



SP01 POST - W4L22341
(x1) 3 3/8"x3 3/8"x77 13/16" (86x86x1976)



SP04 POST - W4L22344
(x1) 3 3/8"x3 3/8"x74 1/4" (86x86x1886)



OJ01 WALL BOARD - W4L22347
(x1) 1 3/16"x5 1/4"x63 1/16" (30x134x1602)



OJ02 WALL BOARD - W4L22348
(x14) 1 3/16"x5 1/4"x63 1/16" (30x134x1602)



OJ09 WALL BOARD - W4L22357
(x1) 1 3/16"x5 1/4"x63 1/16" (30x134x1602)

- RECOMMEND USING SAWHORSES FOR STEPS 7-9.
- LAY WALL BOARDS IN GROOVE AS SHOWN.
- HOLD DIMENSION AND TIGHTEN HARDWARE.
- EVENLY SPACE WALL BOARDS.

HOLES ON BOTH POST ARE TO BE TOWARDS THE TOP AND FACE OUTWARDS

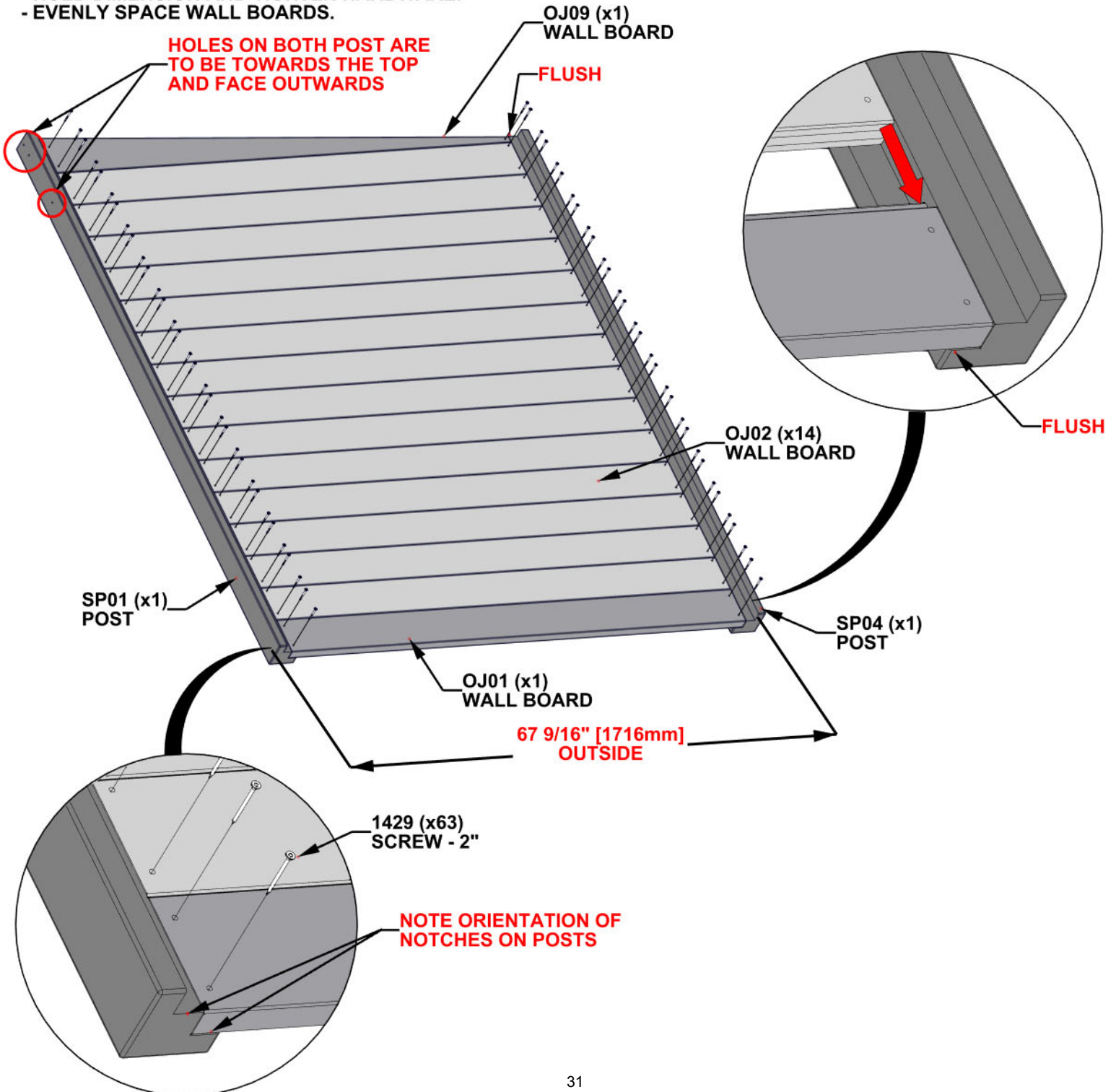

OJ09 (x1) WALL BOARD

FLUSH

OJ02 (x14) WALL BOARD

FLUSH

SP01 (x1) POST

SP04 (x1) POST

OJ01 (x1) WALL BOARD

67 9/16" [1716mm] OUTSIDE

1429 (x63) SCREW - 2"

NOTE ORIENTATION OF NOTCHES ON POSTS

STEP 8 - RIGHT WALL ASSEMBLY

QTY	PART NUMBER	DESCRIPTION
63	H101429	SCREW TFH 8X2 SS-BLK



SP02 POST - W4L22342
(x1) 3 3/8"x3 3/8"x77 13/16" (86x86x1976)



SP03 POST - W4L22343
(x1) 3 3/8"x3 3/8"x73 1/16" (86x86x1856)



OJ01 WALL BOARD - W4L22347
(x1) 1 3/16"x5 1/4"x63 1/16" (30x134x1602)



OJ02 WALL BOARD - W4L22348
(x14) 1 3/16"x5 1/4"x63 1/16" (30x134x1602)

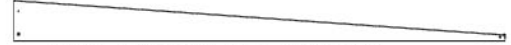

OJ09 WALL BOARD - W4L22357
(x1) 1 3/16"x5 1/4"x63 1/16" (30x134x1602)

- LAY WALL BOARDS IN GROOVE AS SHOWN.
- HOLD DIMENSION AND TIGHTEN HARDWARE.
- EVENLY SPACE WALL BOARDS.

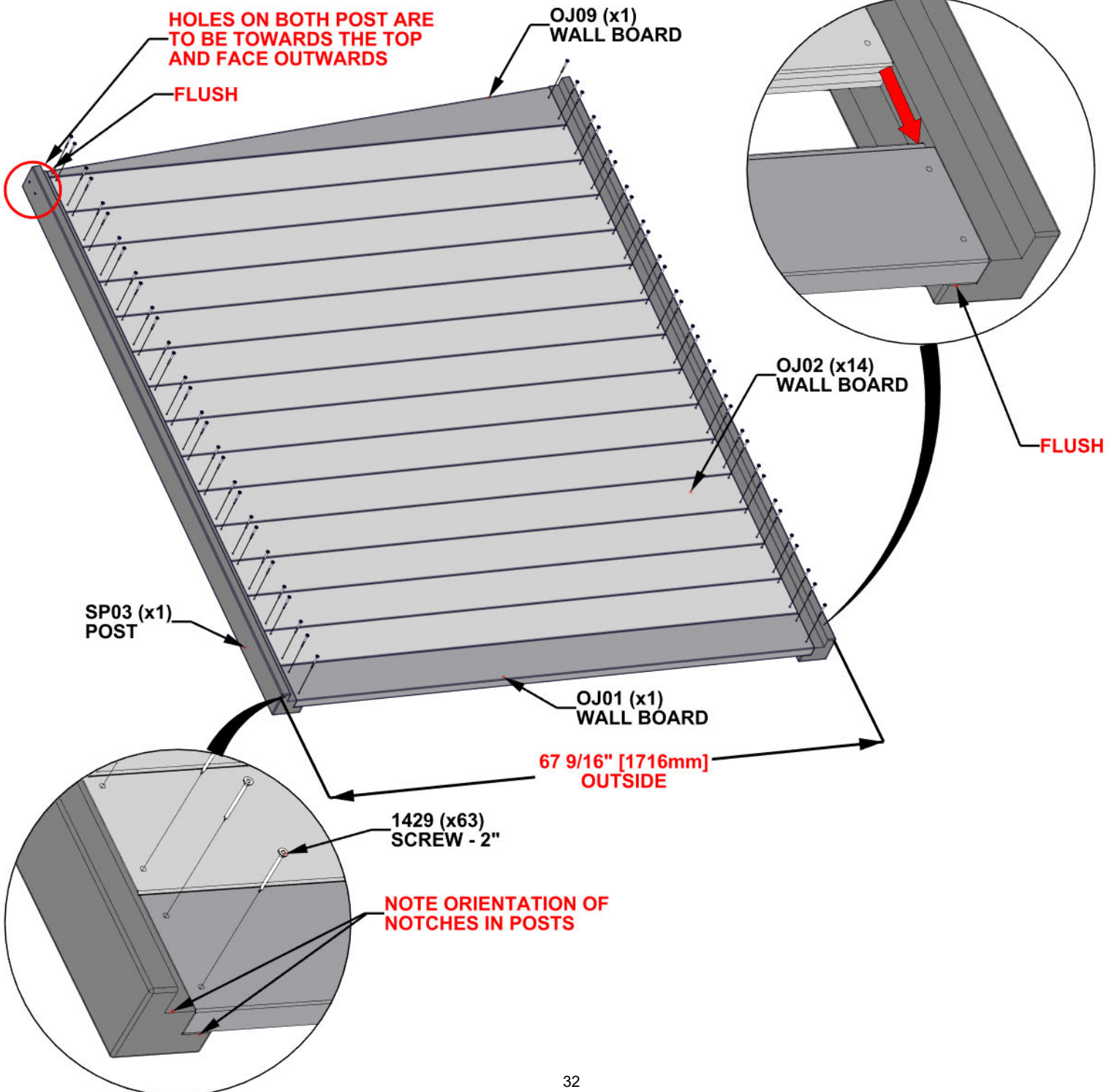

STEP 9 - WALL ASSEMBLY

QTY	PART NUMBER	DESCRIPTION
20	H101429	SCREW TFH 8X2 SS-BLK



E01 TRIM BOARD - W4L22345
(x2) 1 7/16"x3 3/8"x60 3/8" (36x86x1534)



HB01 WALL BOARD - W4L22356
(x2) 15/16"x2 3/4"x48 1/16" (24x70x1220)

- ALIGN HOLES IN BOARD HB01 WITH PILOT HOLES IN BOARD E01, THEN FASTEN AS SHOWN.
- REPEAT THIS STEP TWICE.

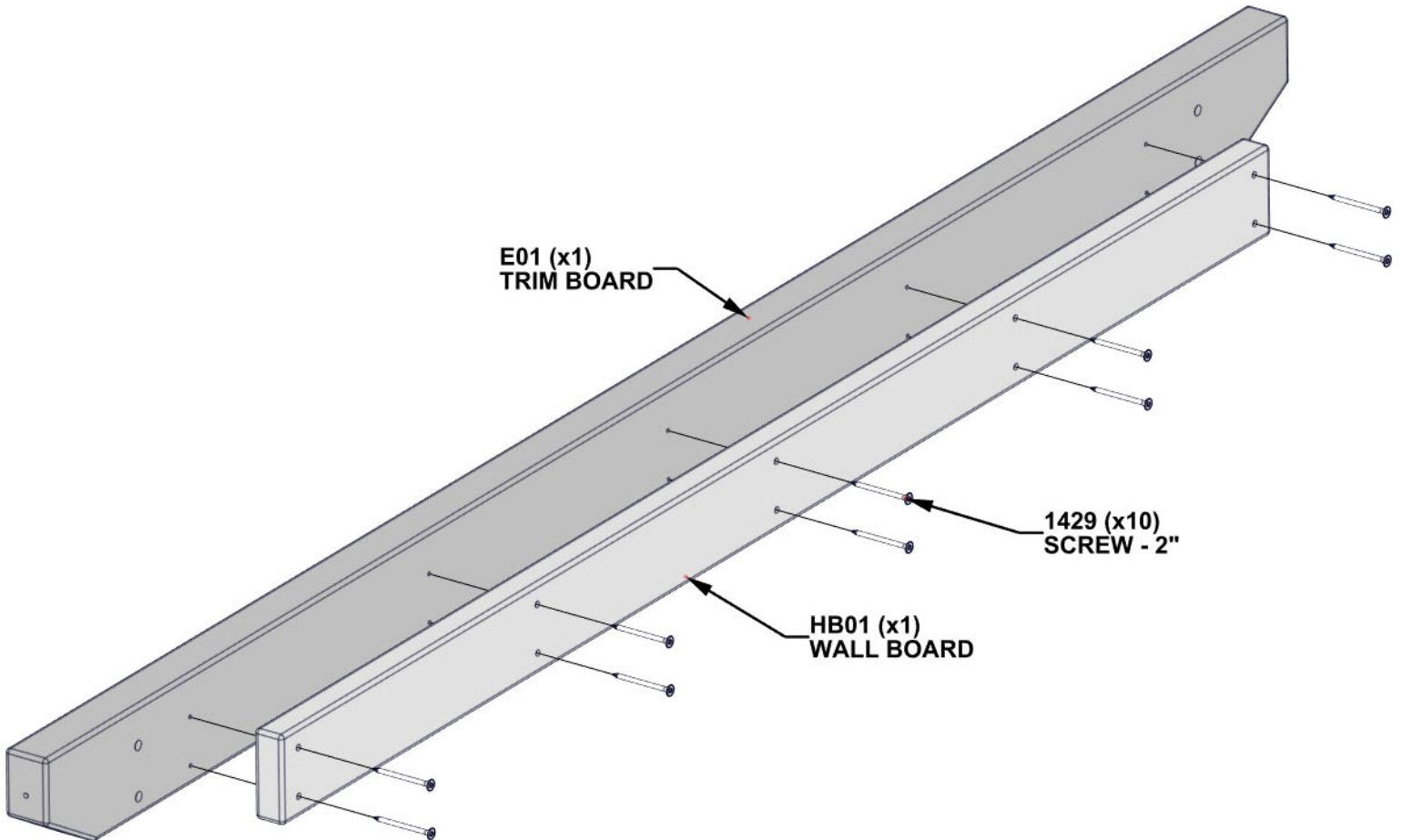

STEP 10 - WALL ASSEMBLY

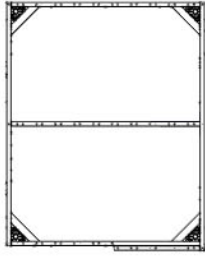

FLOOR FRAME - STEP 6

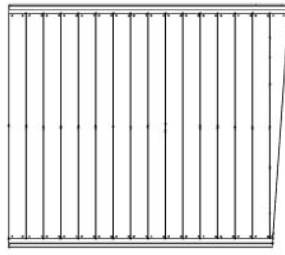

LEFT WALL ASSEMBLY - STEP 7

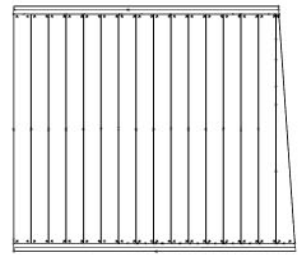

RIGHT WALL ASSEMBLY - STEP 8

- FRONT OF ASSEMBLY IS DETERMINED BY TALLER POST.
- EXTRA PEOPLE MAY BE NEEDED FOR THIS STEP.
- STAND BOTH LEFT AND RIGHT WALL UP AND PUSHED AGAINST FLOOR FRAME.
- NOTE THE FRONT OF THE FLOOR FRAME WILL HAVE OG03 FLOOR JOIST AS SHOWN.

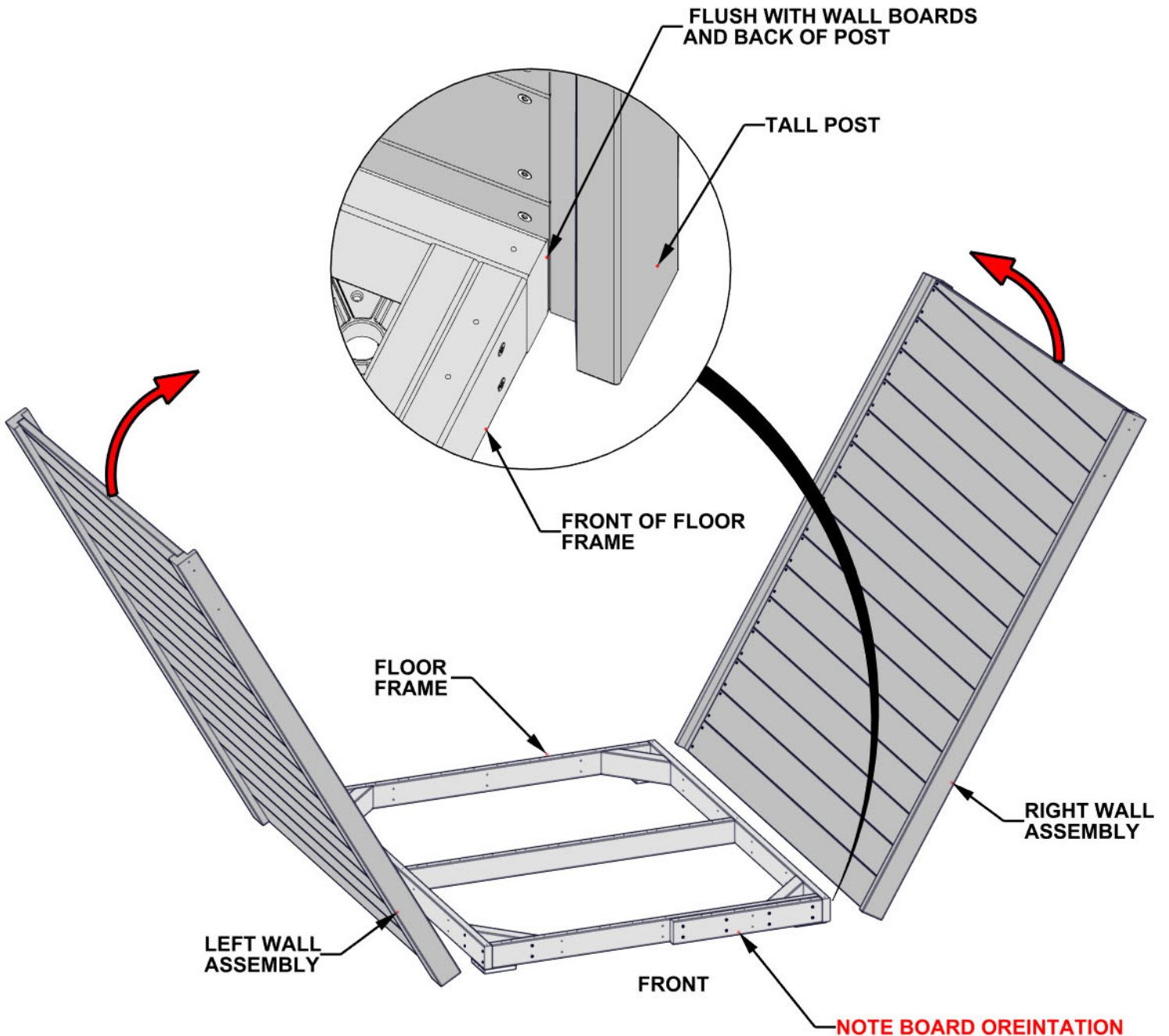

STEP 11 - WALL ASSEMBLY

QTY	PART NUMBER	DESCRIPTION
8	H100405	WASHER LOCK EXT BLK
8	H100487	LAG SCREW WH BLK

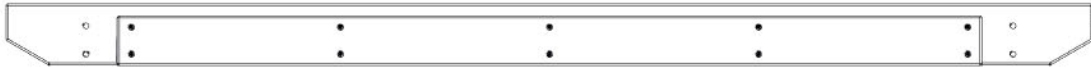

TRIM AND WALL BOARD ASSEMBLY - STEP 9
(x2)

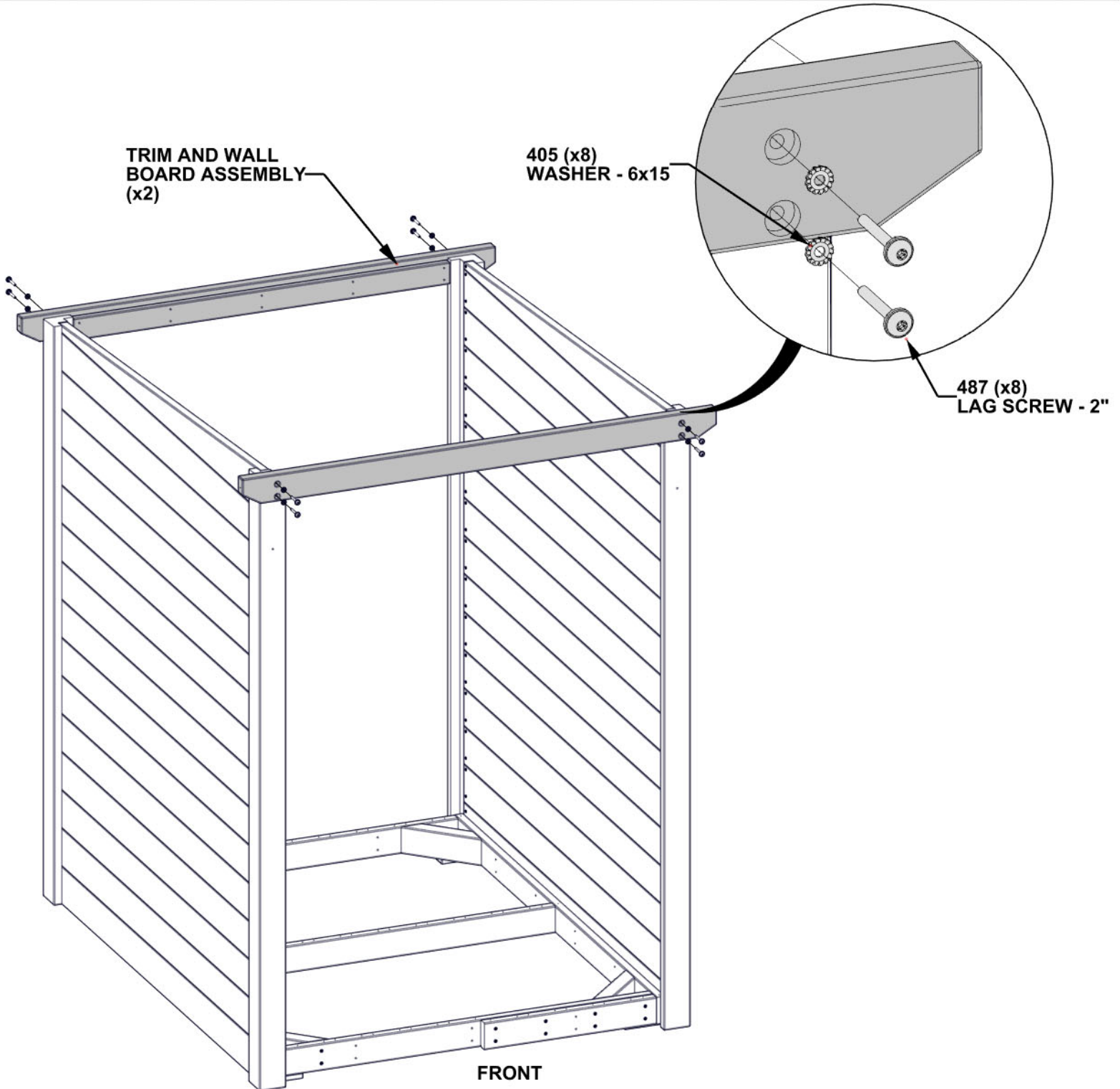

STEP 12 - WALL ASSEMBLY

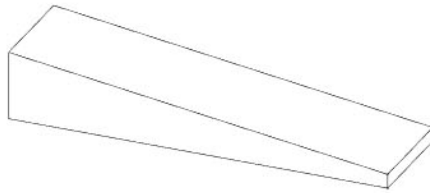

G01 SHIM - W4L22410
(x12) 15/16"x1 1/2"x5 1/4" (24x38x134)

- MAKE SURE FLOOR FRAME IS SQUARE AND LEVEL. SHIMS CAN ALSO BE USED TO LEVEL THE FLOOR FRAME.
- CAREFULLY LIFT WALLS AND USE SHIMS PROVIDED TO ENSURE THAT THE WALL ASSEMBLIES ARE FLUSH WITH THE FLOOR FRAME. SEE DETAIL BELOW.
- MAINTAIN THE 1 3/16" [31mm] GAP SHOWN BELOW ON ALL FOUR POST, FRONT AND BACK.

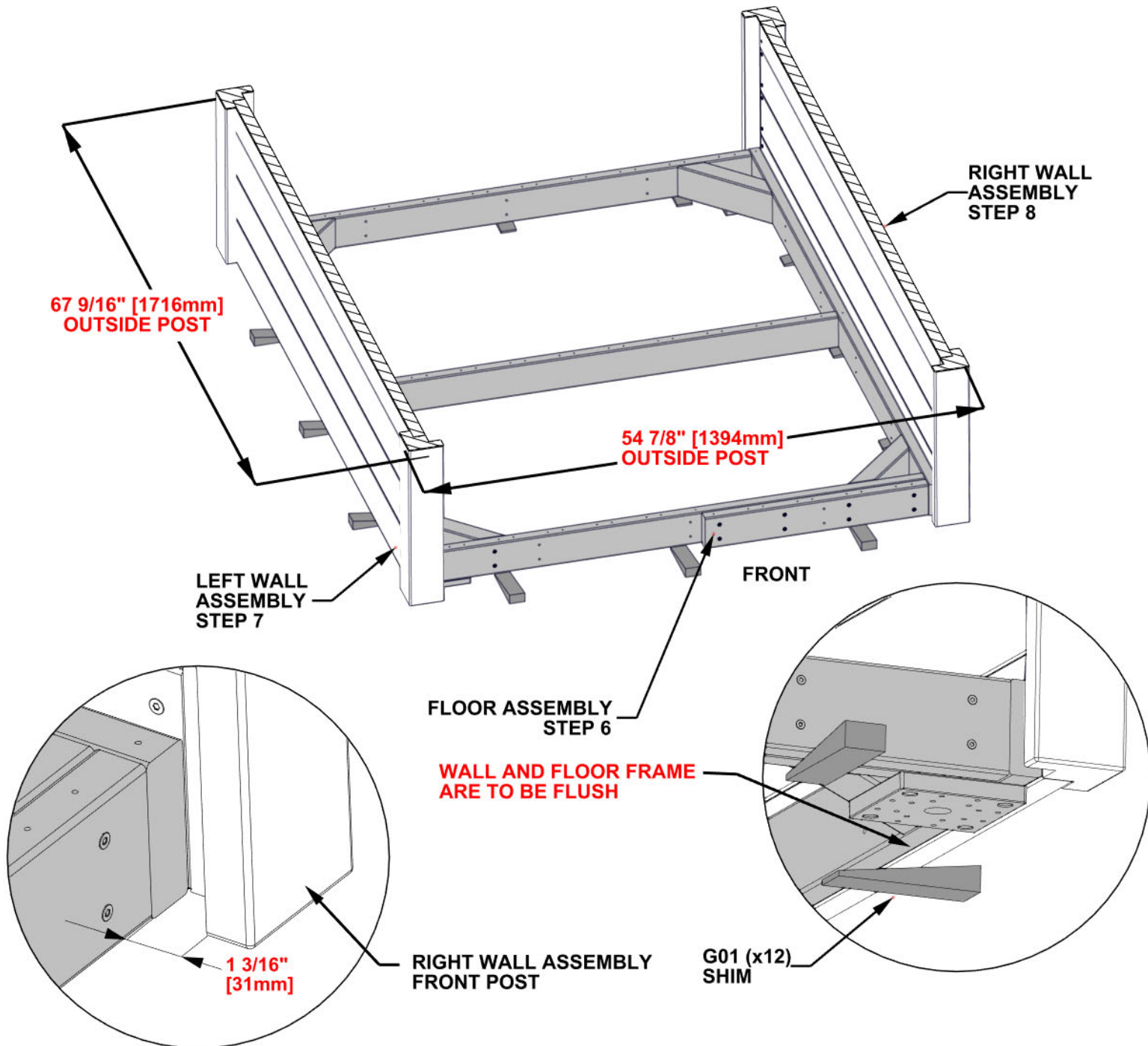

STEP 13 - WALL ASSEMBLY

QTY	PART NUMBER	DESCRIPTION
16	H101429	SCREW TFH 8X2 SS-BLK

- AFTER ENSURING THE FLOOR FRAMING AND WALLS ARE FLUSH, LEVEL AND SQUARE, SECURE THE FLOOR FRAME TO THE WALL ASSEMBLIES AS SHOWN.

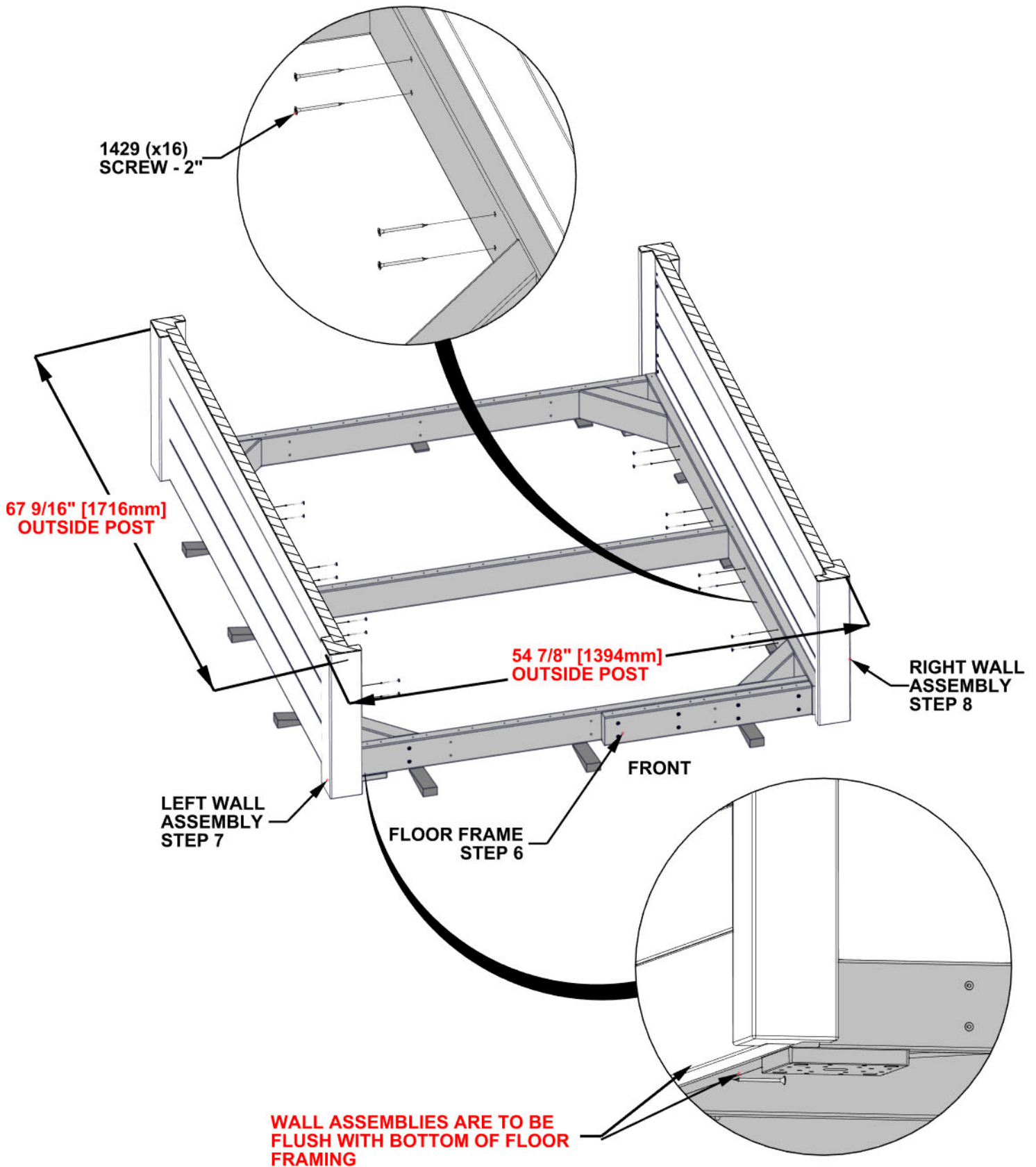

STEP 14 - WALL ASSEMBLY

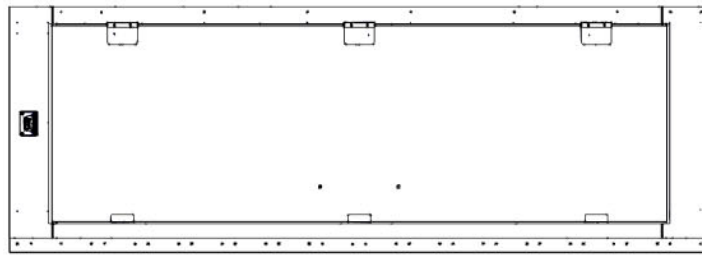

WP01 DOOR DOOR WALL PANEL ASSEMBLY - W2A04911
(x1) 2 3/8"x27 1/4"x77 5/8" (60x692x650)

- BRING DOOR WALL PANEL ASSEMBLY IN FROM THE BACK AND TILT SLIGHTLY WHILE SLIDING DOWN IN BETWEEN NOTCH IN POST AND FLOOR FRAME AS SHOWN.

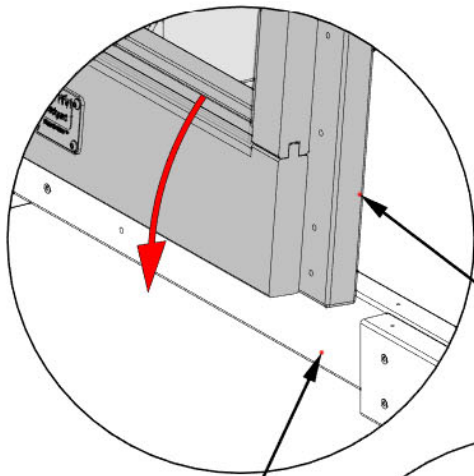

TILT WALL PANEL TO SLIDE IN FRONT OF FLOOR FRAME

FLOOR FRAME

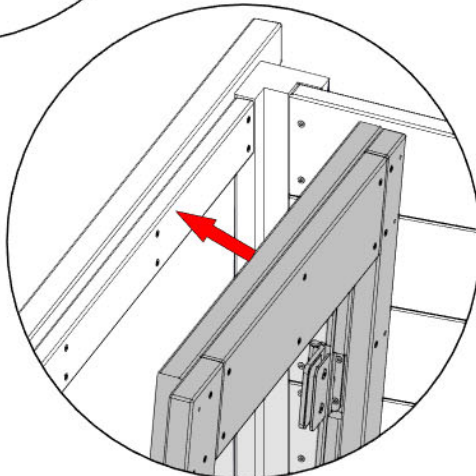

INSIDE VIEW

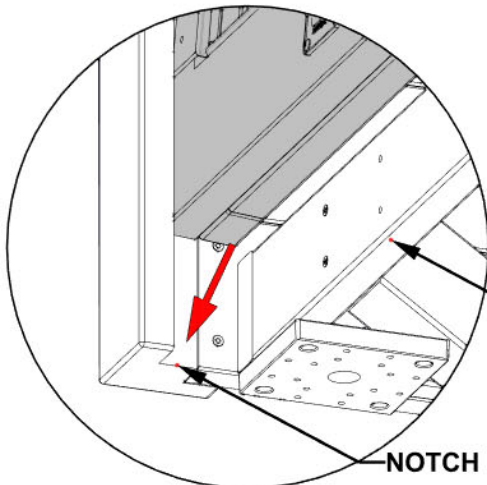

FLOOR FRAME

NOTCH IN POST

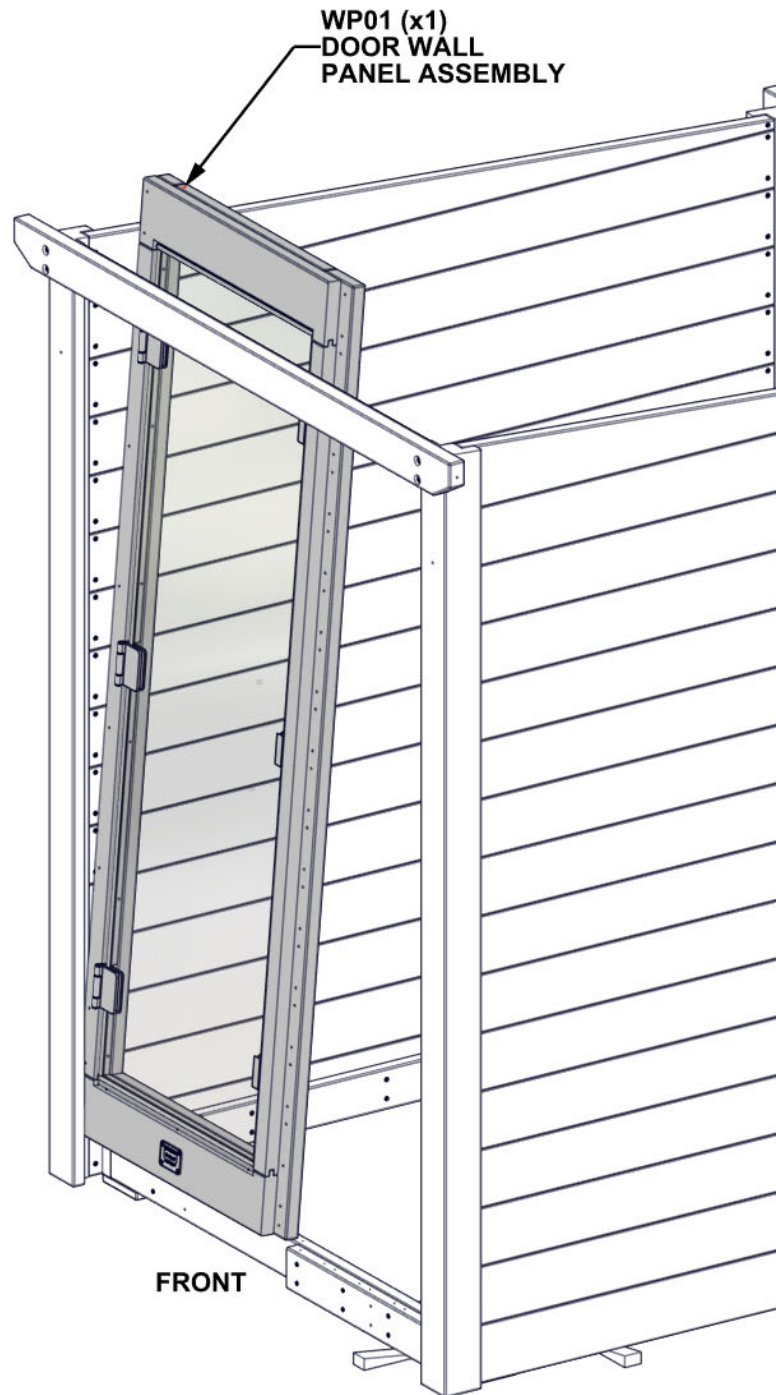

STEP 15 - WALL ASSEMBLY

QTY	PART NUMBER	DESCRIPTION
2	H101429	SCREW TFH 8X2 SS-BLK
9	H101433	SCREW TFH 8X3 SS-BLK
6	H101435	SCREW TFH 8X3 1/2 SS-BLK

- IT IS IMPORTANT THAT THE FLOOR, WALLS AND DOOR WALL PANEL ARE SQUARE AND LEVEL BEFORE ATTACHING.

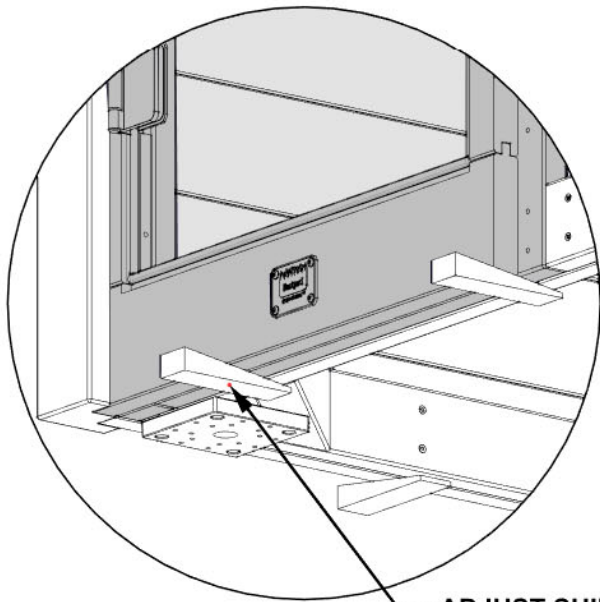

OUTSIDE VIEW

ADJUST SHIMS FROM STEP 12 TO ENSURE WALL PANEL ASSEMBLY IS FLUSH WITH WALLS AND FLOOR FRAME

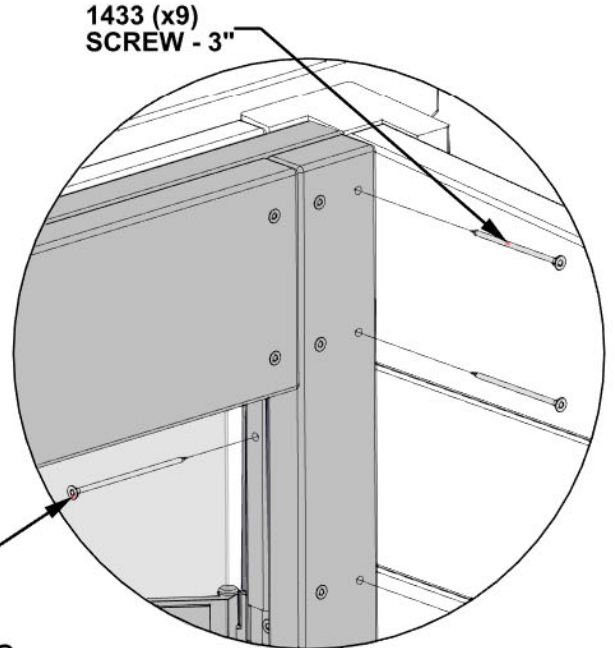

1433 (x9)
SCREW - 3"

1435 (x6)
SCREW - 3 1/2"

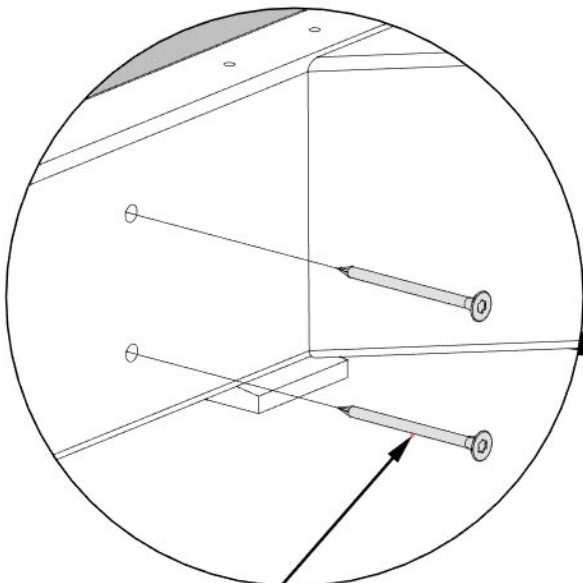

1429 (x2)
SCREW - 2"

RIGHT AND BACK WALLS
HIDDEN FOR DETAIL

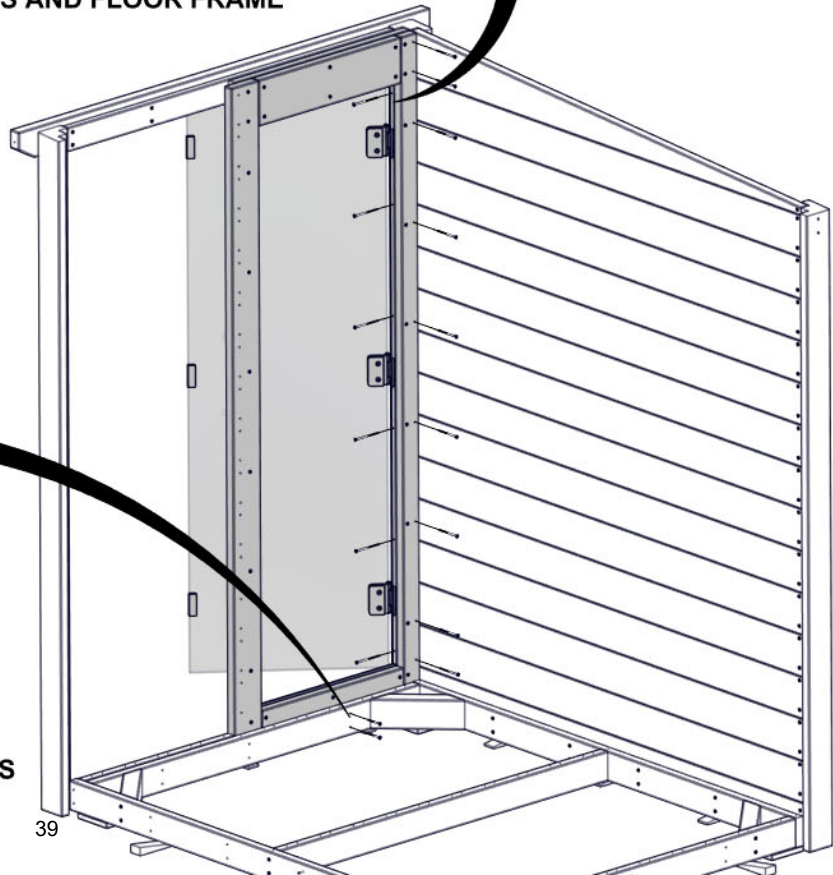

STEP 16 - FRONT WALL ASSEMBLY

QTY	PART NUMBER	DESCRIPTION
29	H101429	SCREW TFH 8X2 SS-BLK
4	H101434	SCREW TFH 8X3 1/4 SS-BLK

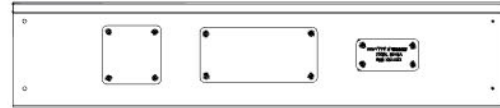
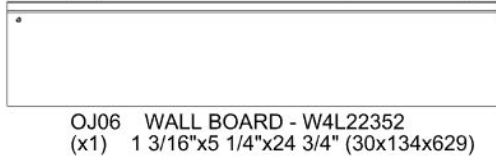
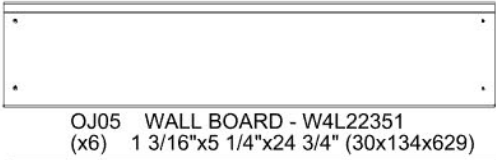

- SLIDE OJ06 BETWEEN FLOOR FRAME AND POST.
- ADJUST SHIMS AS NEEDED TO ENSURE THAT OJ06 IS FLUSH WITH BOTTOM OF FLOOR FRAME AND LEVEL.
- STACK OTHER WALL BOARDS ON TOP AS SHOWN.
- ALIGN HOLES IN WALL BOARDS WITH PILOT HOLES IN POST AND DOOR WALL PANEL ASSEMBLY AND ATTACH AS SHOWN.

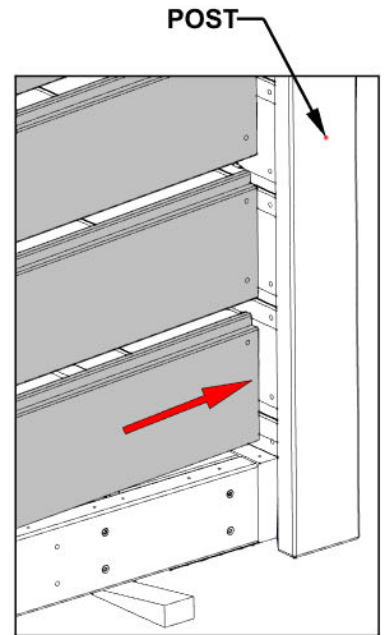
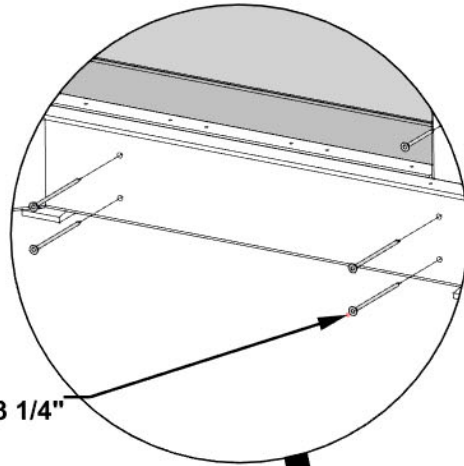
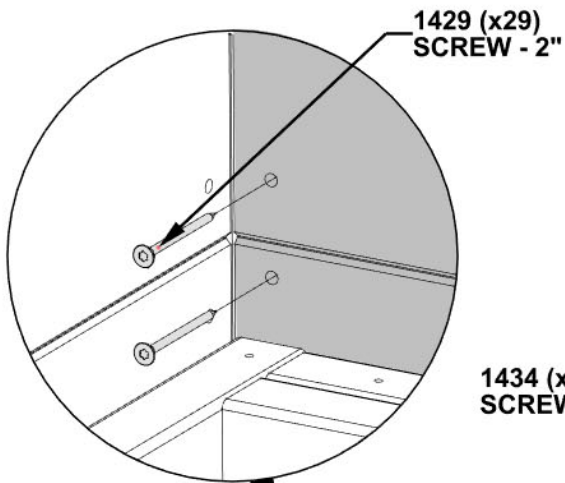

OUTSIDE VIEW

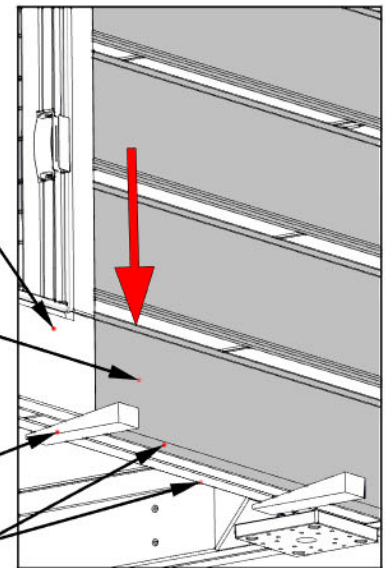
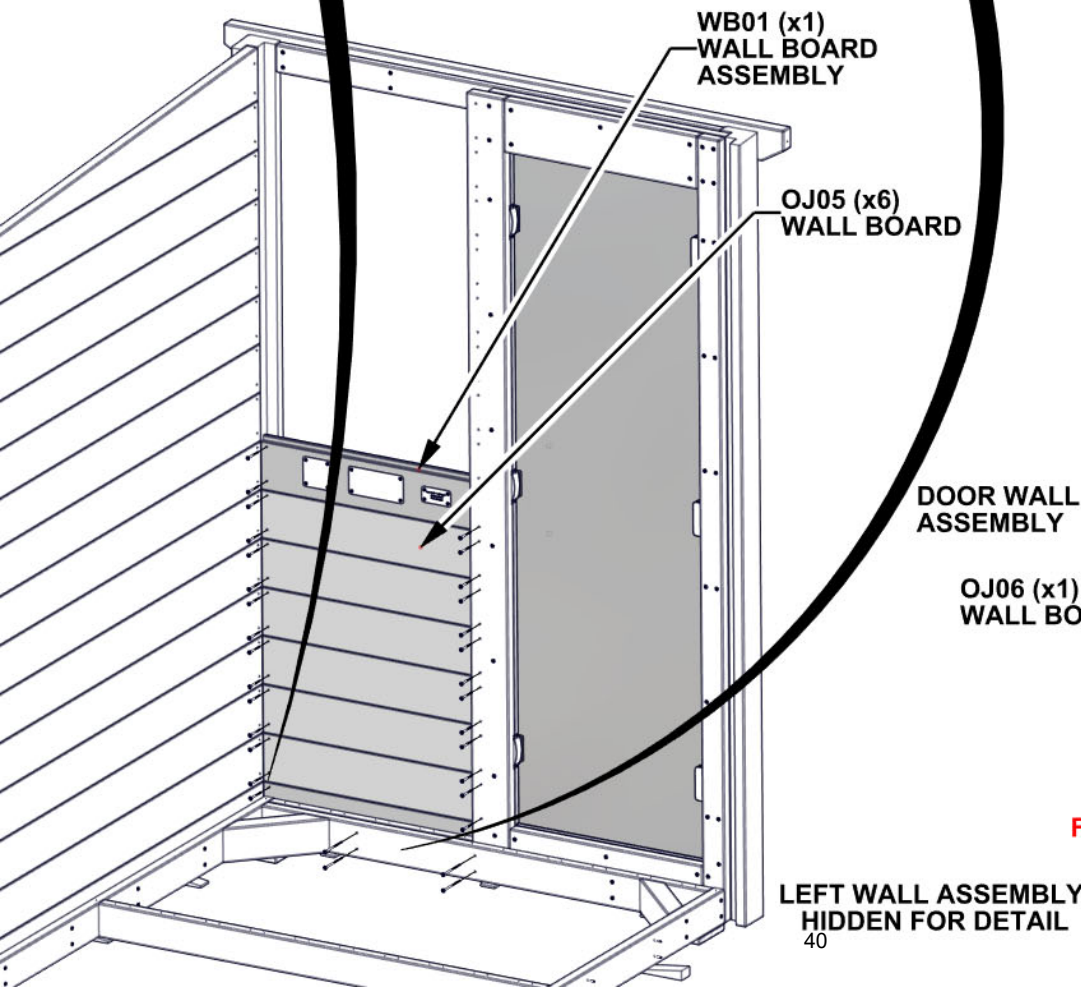

OUTSIDE VIEW

STEP 17 - FRONT WALL ASSEMBLY

QTY	PART NUMBER	DESCRIPTION
32	H101429	SCREW TFH 8X2 SS-BLK



OJ05 WALL BOARD - W4L22351
(x4) 1 3/16"x5 1/4"x24 3/4" (30x134x629)



OJ17 WALL BOARD - W4L22394
(x1) 1 3/16"x5 1/4"x24 3/4" (30x134x629)



OJ18 WALL BOARD - W4L22395
(x1) 1 3/16"x5 1/4"x24 3/4" (30x134x629)



OJ07 WALL BOARD - W4L22353
(x1) 1 3/16"x5 1/4"x24 3/4" (30x134x629)



OJ21 WALL BOARD - W4L22408
(x1) 1 3/16"x5 1/4"x24 3/4" (30x134x629)

- STACK REMAINING WALL BOARDS AS SHOWN. NOTE THRU HOLE PLACEMENT.
- ALIGN HOLES IN WALL BOARDS WITH PILOT HOLES IN POST AND DOOR WALL PANEL ASSEMBLY AND ATTACH AS SHOWN.
- THE LAST WALL BOARD OJ07 WILL NEED TO SLIDE IN FROM THE TOP OF THE DOOR WALL PANEL ASSEMBLY.

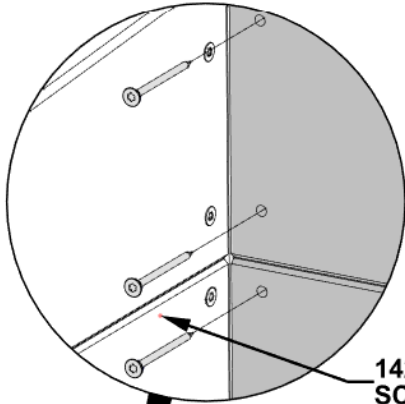

1429 (x32)
SCREW - 2"

OJ07 (x1)
WALL BOARD

OJ18 (x1)
WALL BOARD

OJ17 (x1)
WALL BOARD

OJ21 (x1)
WALL BOARD

**NOTE THRU HOLES FOR
PROPER PLACEMENT OF
WALL BOARDS**

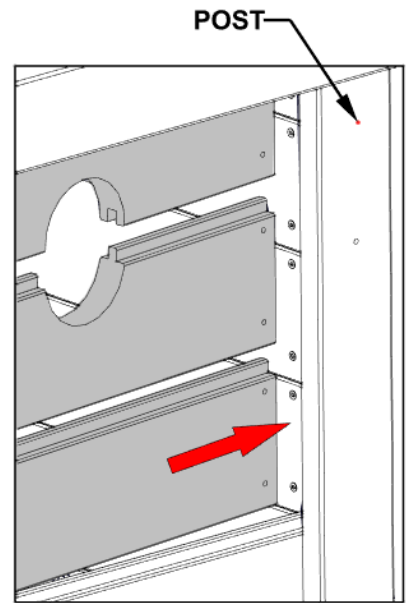

OUTSIDE VIEW

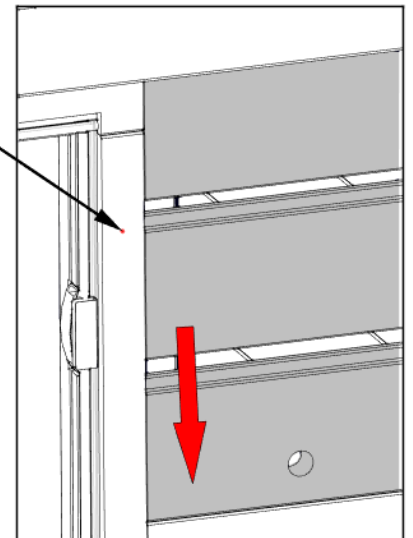

OUTSIDE VIEW

DOOR WALL PANEL
ASSEMBLY

OJ05 (x4)
WALL BOARD

STEP 18 - BACK WALL ASSEMBLY

QTY	PART NUMBER	DESCRIPTION
14	H101429	SCREW TFH 8X2 SS-BLK



OJ03 WALL BOARD - W4L22349
(x1) 1 3/16"x5 1/4"x50 3/8" (30x134x1280)



OJ15 WALL BOARD - W4L22390
(x1) 1 3/16"x5 1/4"x50 3/8" (30x134x1280)

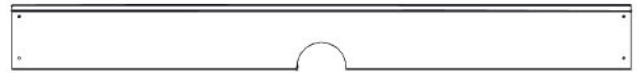

OJ20 WALL BOARD - W4L22397
(x1) 1 3/16"x5 1/4"x50 3/8" (30x134x1280)

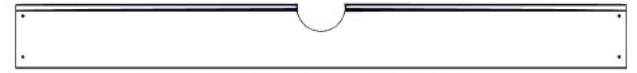

OJ19 WALL BOARD - W4L22396
(x1) 1 3/16"x5 1/4"x50 3/8" (30x134x1280)

- SLIDE OJ03 BETWEEN FLOOR FRAME AND POSTS.
- ADJUST SHIMS AS NEEDED TO ENSURE THAT OJ03 IS FLUSH WITH BOTTOM OF FLOOR FRAME AND LEVEL.
- STACK OTHER WALL BOARDS ON TOP AS SHOWN.
- ALIGN HOLES IN WALL BOARDS WITH PILOT HOLES IN POSTS AND ATTACH AS SHOWN.

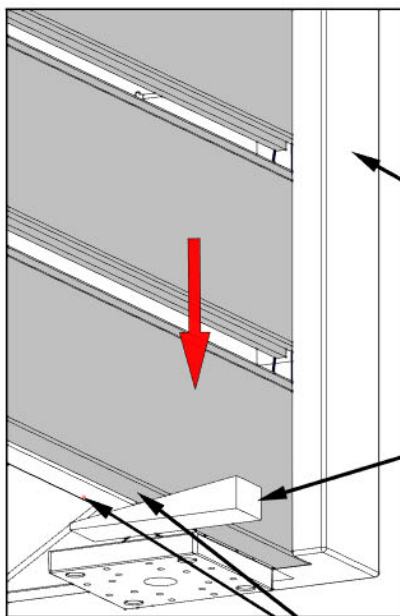
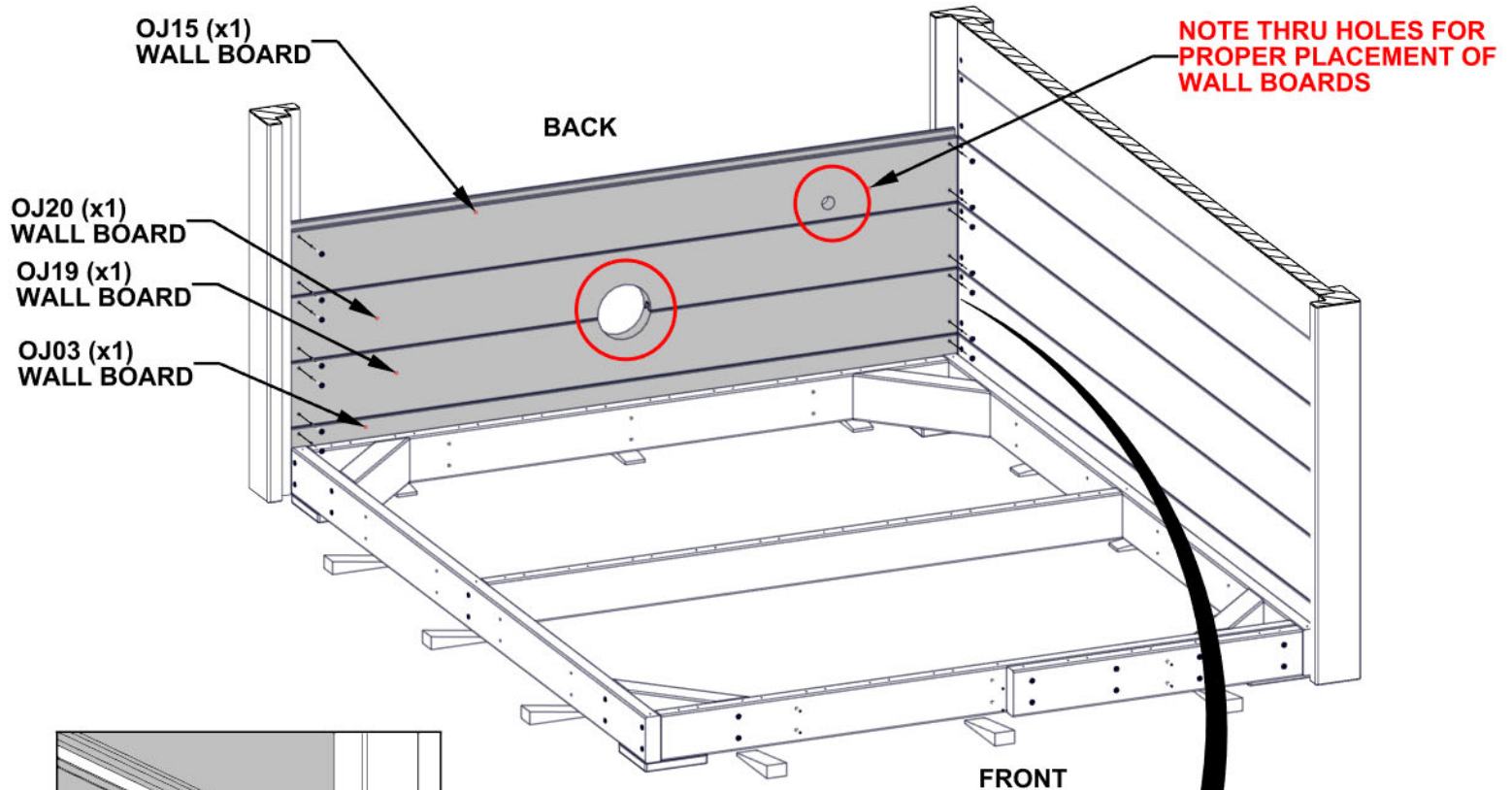

OUTSIDE VIEW **FLUSH**

LEFT WALL AND FRONT WALL HIDDEN FOR DETAIL

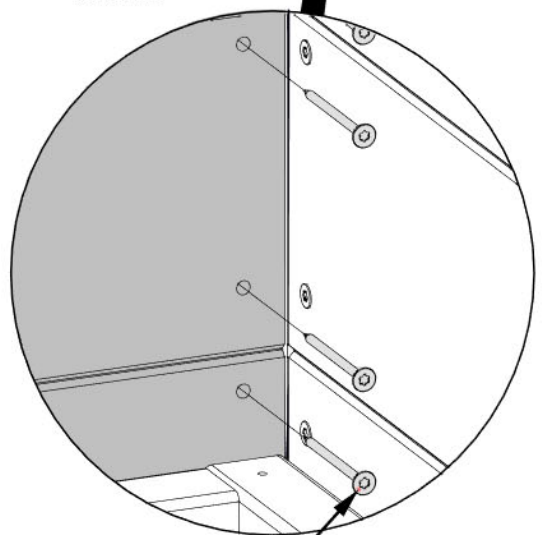

1429 (x14)
SCREW - 2"

STEP 19 - BACK WALL ASSEMBLY

QTY	PART NUMBER	DESCRIPTION
50	H101429	SCREW TFH 8X2 SS-BLK

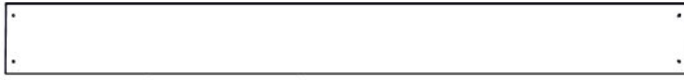

OJ08 WALL BOARD - W4L22354
(x1) 1 3/16"x5 1/4"x50 3/8" (30x134x1280)



OJ04 WALL BOARD - W4L22350
(x9) 1 3/16"x5 1/4"x50 3/8" (30x134x1280)



OJ16 WALL BOARD - W4L22392
(x1) 1 3/16"x5 1/4"x50 3/8" (30x134x1280)

- EVENLY SPACE REMAINING WALL BOARDS AS SHOWN. NOTE THRU HOLE PLACEMENTS.
- ALIGN HOLES IN WALL BOARDS WITH PILOT HOLES IN POSTS AND ATTACH AS SHOWN.

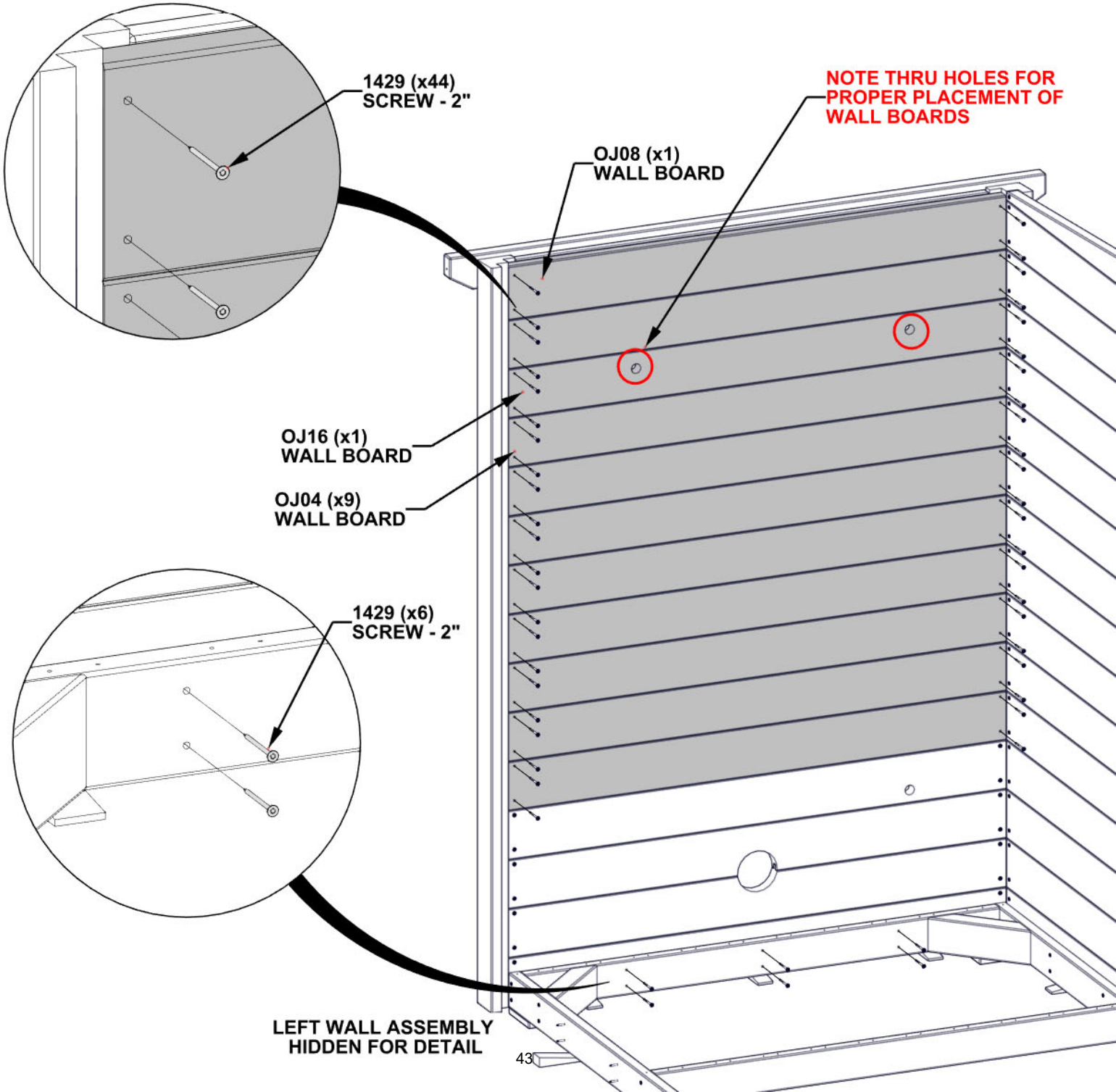

STEP 20 - FLOOR ASSEMBLY

QTY	PART NUMBER	DESCRIPTION
30	H101429	SCREW TFH 8X2 SS-BLK



OJ12 FLOOR BOARD - W4L22376
(x4) 1 3/16"x5 1/4"x61 7/8" (30x134x1572)

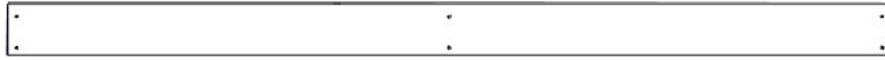

OS02 FLOOR BOARD - W4L22375
(x1) 1 3/16"x3 11/16"x61 7/8" (30x94x1572)

- ALIGN HOLES IN FLOOR BOARDS WITH PILOT HOLES IN FLOOR FRAME.

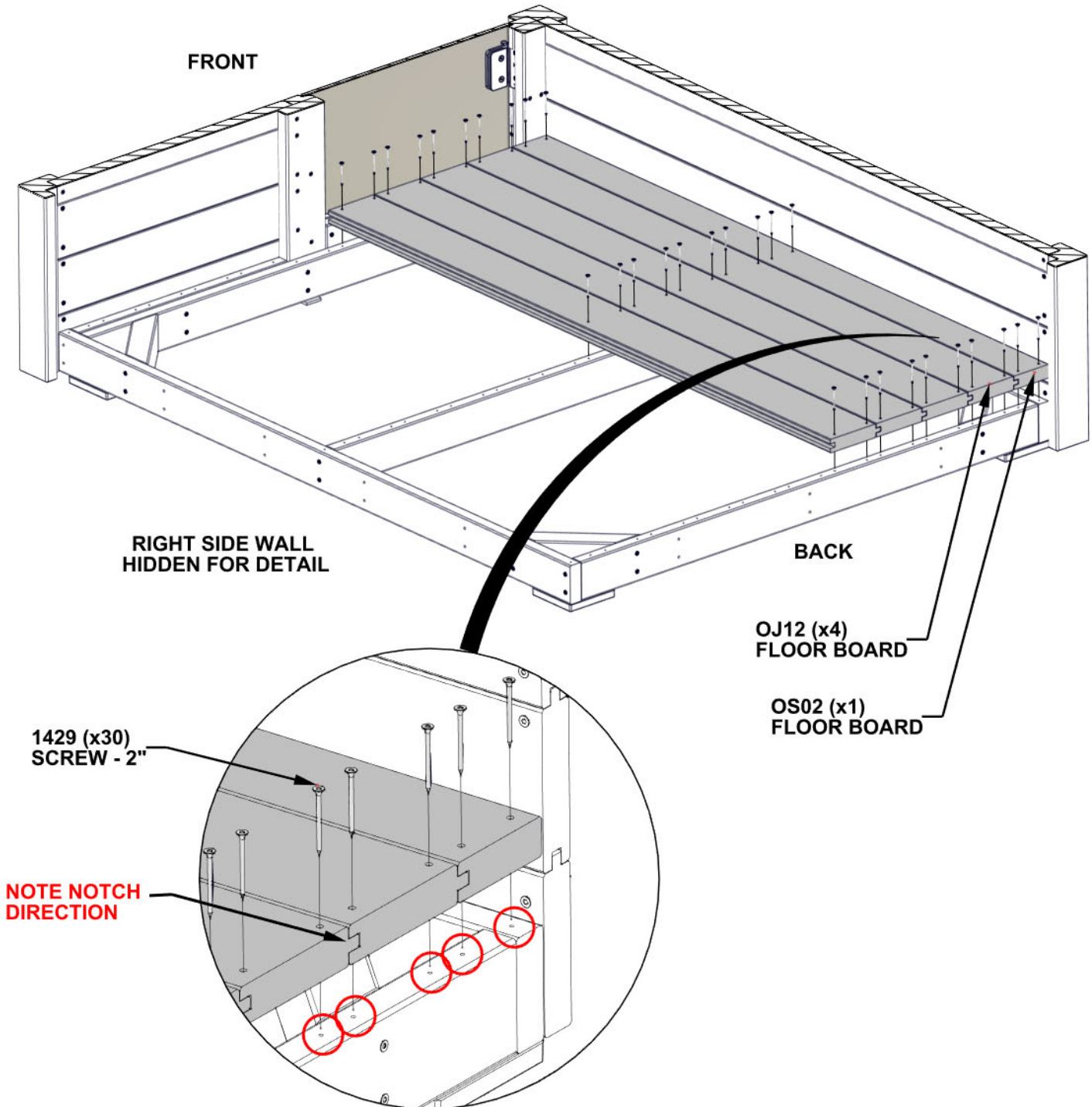

STEP 21 - FLOOR ASSEMBLY

QTY	PART NUMBER	DESCRIPTION
36	H101429	SCREW TFH 8X2 SS-BLK



OJ14 FLOOR BOARD - W4L22379
(x1) 1 3/16"x5 1/4"x61 7/8" (30x30x1572)

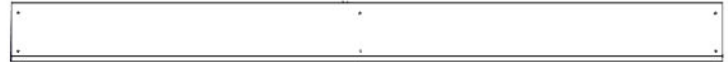

OJ11 FLOOR BOARD - W4L22374
(x3) 1 3/16"x5 1/4"x63 1/16" (30x134x1602)



OJ13 FLOOR BOARD - W4L22377
(x1) 1 3/16"x5 1/4"x63 1/16" (30x134x1602)

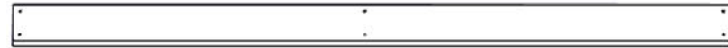

OS01 FLOOR BOARD - W4L22364
(x1) 1 3/16"x3 11/16"x63 1/16" (30x94x1602)

- ALIGN HOLES IN FLOOR BOARDS WITH PILOT HOLES IN FLOOR FRAME.

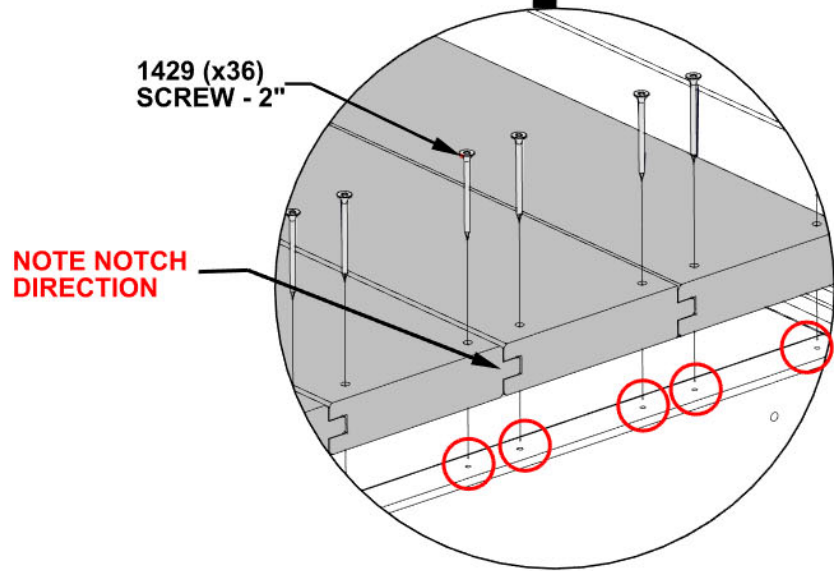
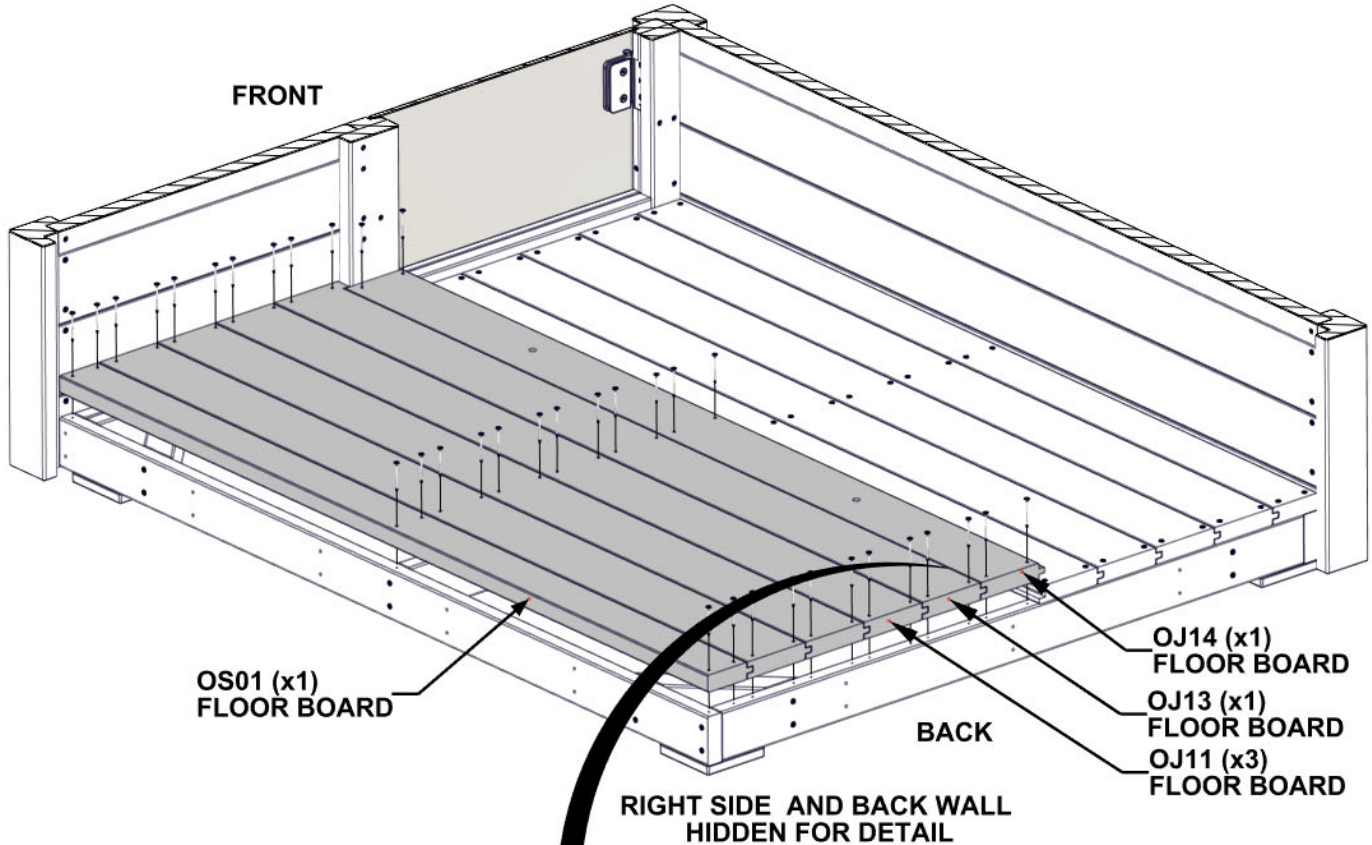

STEP 22 - FLOOR ASSEMBLY

QTY	PART NUMBER	DESCRIPTION
9	H101429	SCREW TFH 8X2 SS-BLK



OO06 FLOOR TRIM - W4L22373
(x1) 1 3/16"x1 3/16"x61 7/8" (30x30x1572)



OO07 FLOOR TRIM - W4L22378
(x1) 1 3/16"x1 3/16"x21 13/16" (30x30x554)

- PRESS FLOOR TRIM AGAINST WALLS AND ATTACH AS SHOWN.

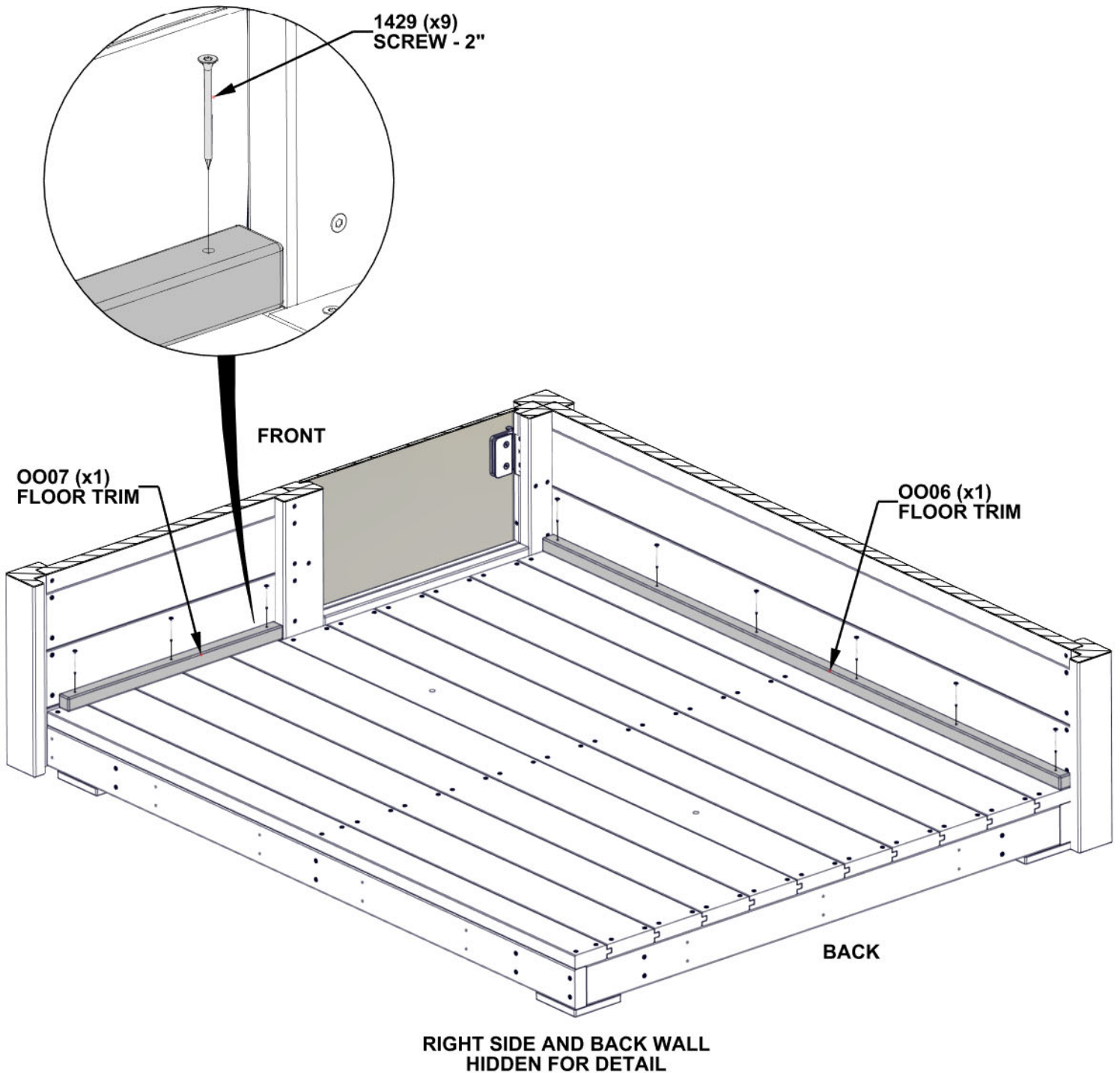

STEP 23 - FLOOR ASSEMBLY

QTY	PART NUMBER	DESCRIPTION
11	H101429	SCREW TFH 8X2 SS-BLK



OO02 FLOOR TRIM - W4L22365
(x1) 1 3/16"x1 3/16"x63 1/16" (30x30x1602)



OO05 FLOOR TRIM - W4L22366
(x1) 1 3/16"x1 3/16"x48 1/16" (30x30x1220)

- PRESS FLOOR TRIM AGAINST WALLS AND ATTACH AS SHOWN.

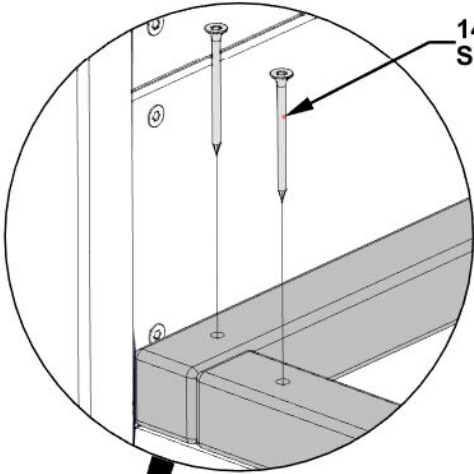

1429 (x11)
SCREW - 2"

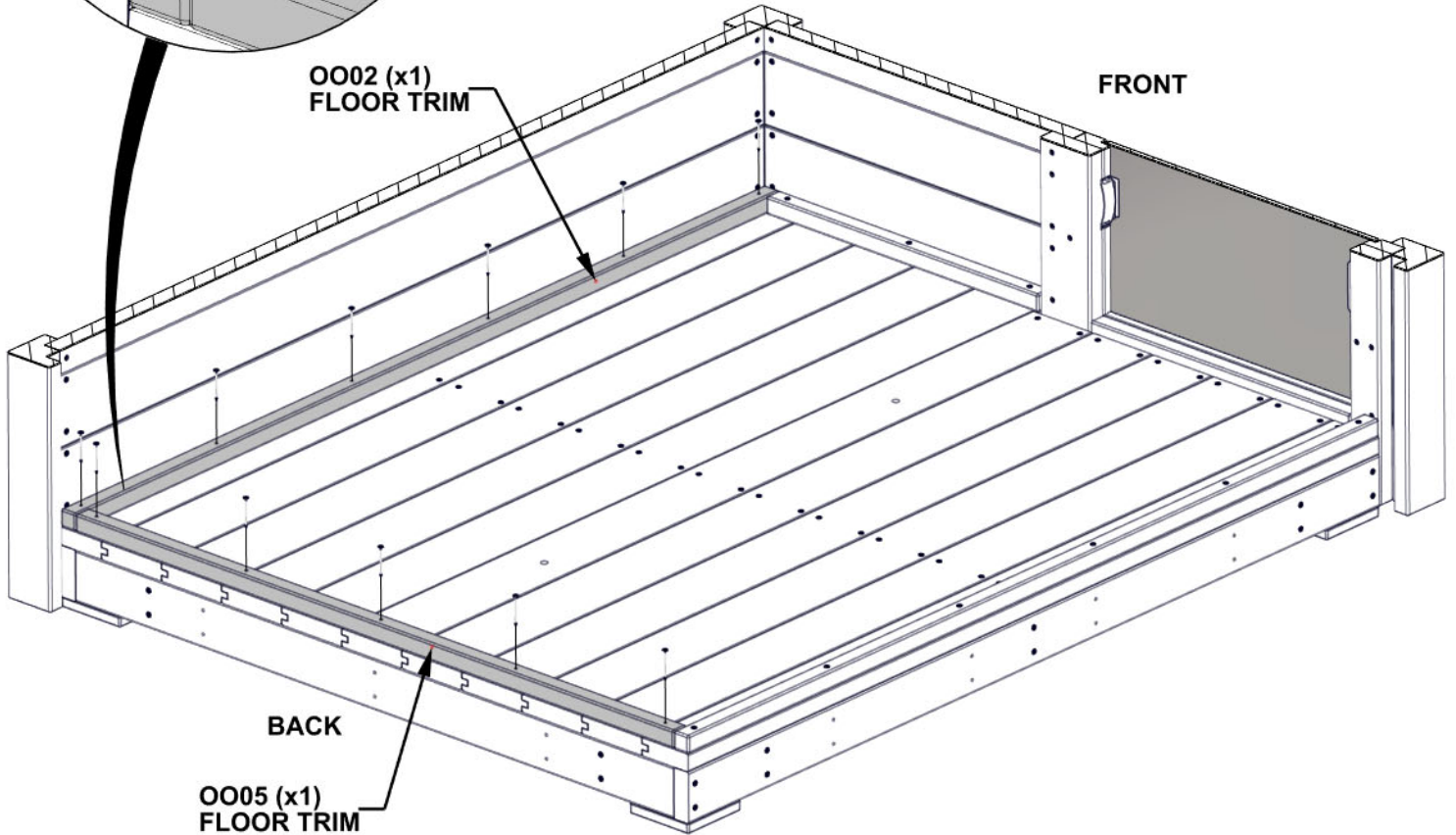

LEFT SIDE AND BACK WALL
HIDDEN FOR DETAIL

STEP 24 - HANDLE ASSEMBLY

QTY	PART NUMBER	DESCRIPTION
2	H101402	SCREW TFH SS
4	H101403	POLY WASHER

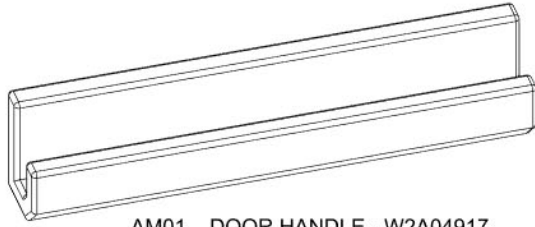

AM01 DOOR HANDLE - W2A04917
(x) 2 1/4"x3"x13 5/16" (57x76x338)

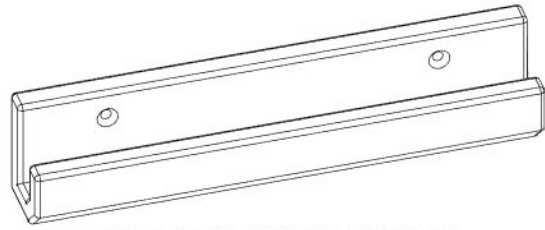

AM02 DOOR HANDLE - W4L22361
(x1) 2 1/4"x3"x13 5/16" (57x76x338)

- ATTACH DOOR HANDLES AS SHOWN.
- DO NOT OVERTIGHTEN.

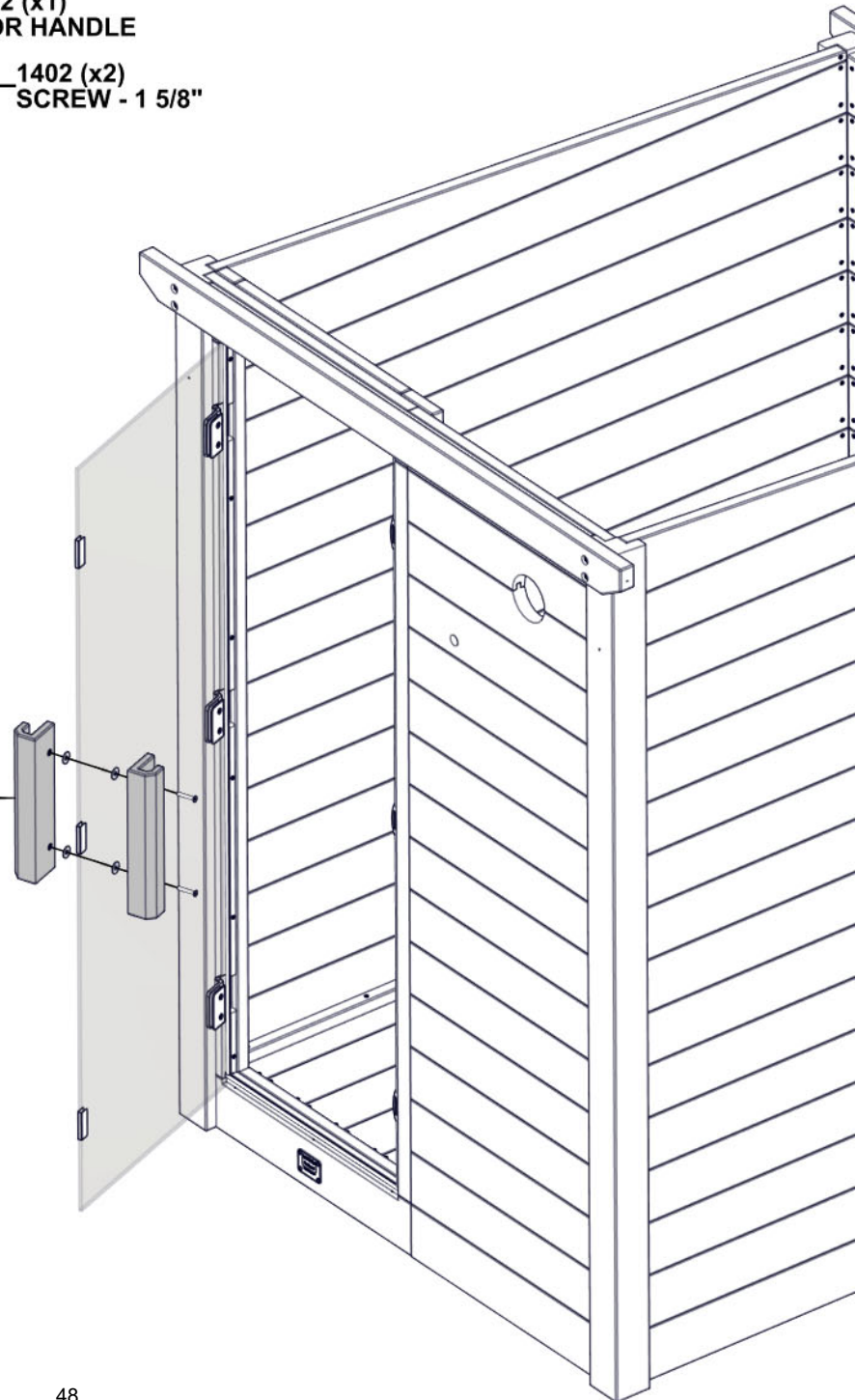
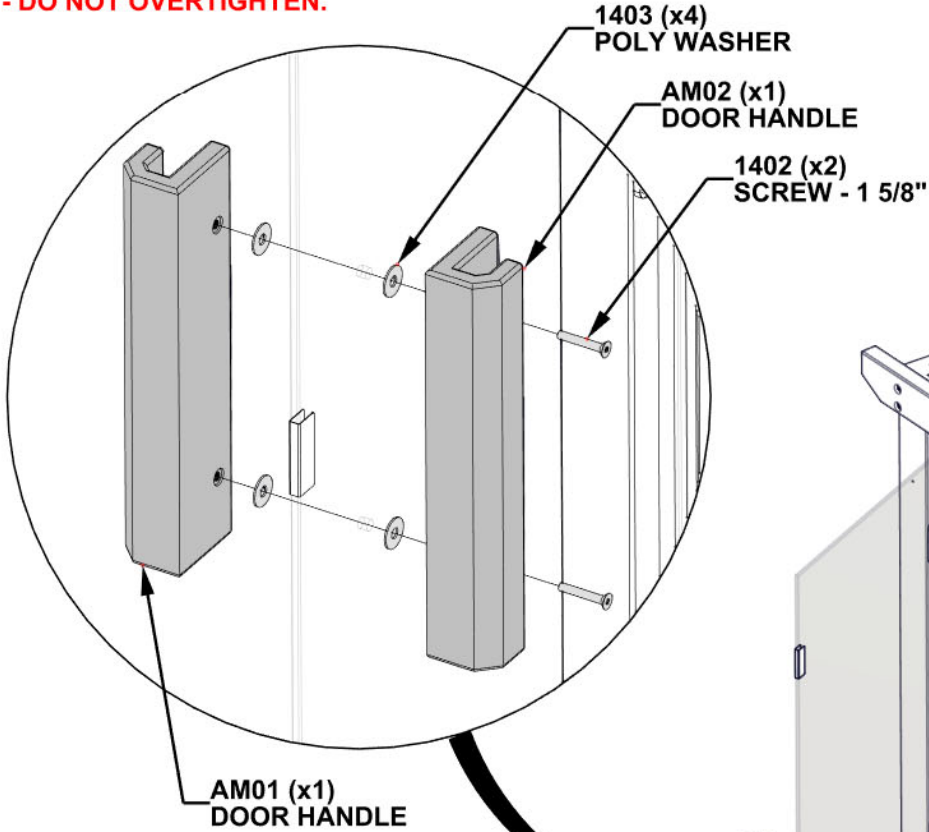

STEP 25 - BENCH ASSEMBLY

QTY	PART NUMBER	DESCRIPTION
17	H101429	SCREW TFH 8X2 SS-BLK



OG08 SEAT CLEAT - W4L22384
(x1) 1 3/16"x3 3/8"x19 1/8" (30x86x486)

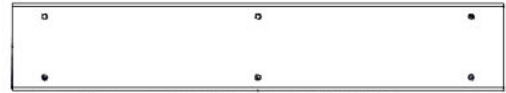

OG15 SEAT CLEAT - W4L22407
(x1) 1 3/16"x3 3/8"x19 1/8" (30x86x486)

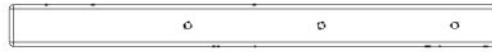

OO01 SLAT CLEAT - W4L22404
(x) 1 3/16"x1 3/16"x14" (30x30x355)

- NOTE PILOT HOLES TO BE INSTALLED ON THE TOP SIDE.
- FLUSH END OF OG08 AGAINST BACK WALL.
- ENSURE THAT BOARDS ARE LEVEL AND THEN ATTACH AS SHOWN.

**NOTE HOLE LOCATIONS FOR
CORRECT BOARD ORIENTATION**

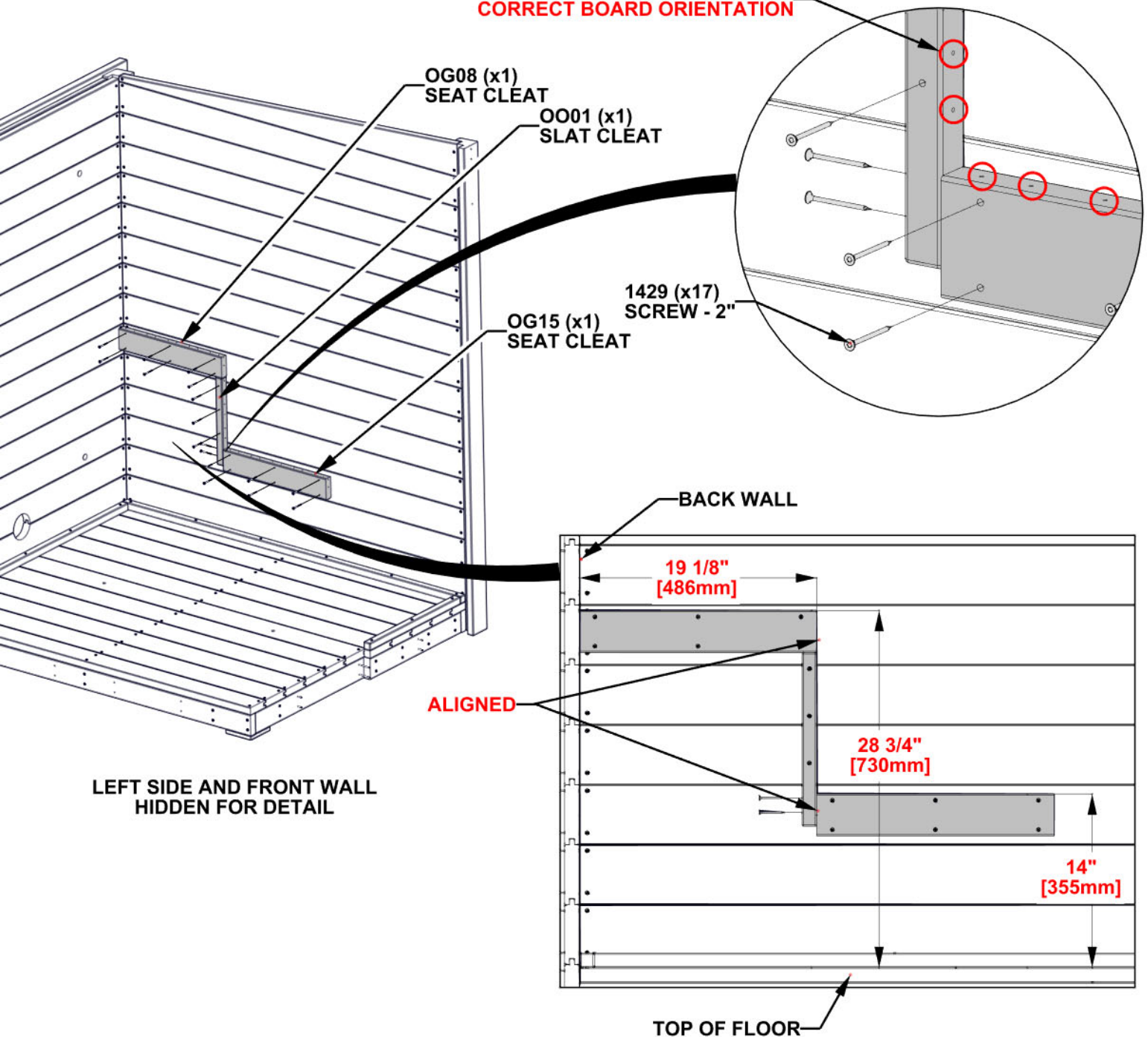

STEP 26 - BENCH ASSEMBLY

QTY	PART NUMBER	DESCRIPTION
17	H101429	SCREW TFH 8X2 SS-BLK



OG08 SEAT CLEAT - W4L22384
(x1) 1 3/16"x3 3/8"x19 1/8" (30x86x486)



OG15 SEAT CLEAT - W4L22407
(x1) 1 3/16"x3 3/8"x19 1/8" (30x86x486)

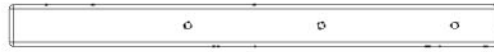

OO01 SLAT CLEAT - W4L22404
(x1) 1 3/16"x1 3/16"x14" (30x30x355)

- NOTE PILOT HOLES TO BE INSTALLED ON THE TOP SIDE.
- FLUSH END OF OG08 AGAINST BACK WALL.
- ENSURE THAT BOARDS ARE LEVEL AND THEN ATTACH AS SHOWN.

**NOTE HOLE LOCATIONS FOR
CORRECT BOARD ORIENTATION**

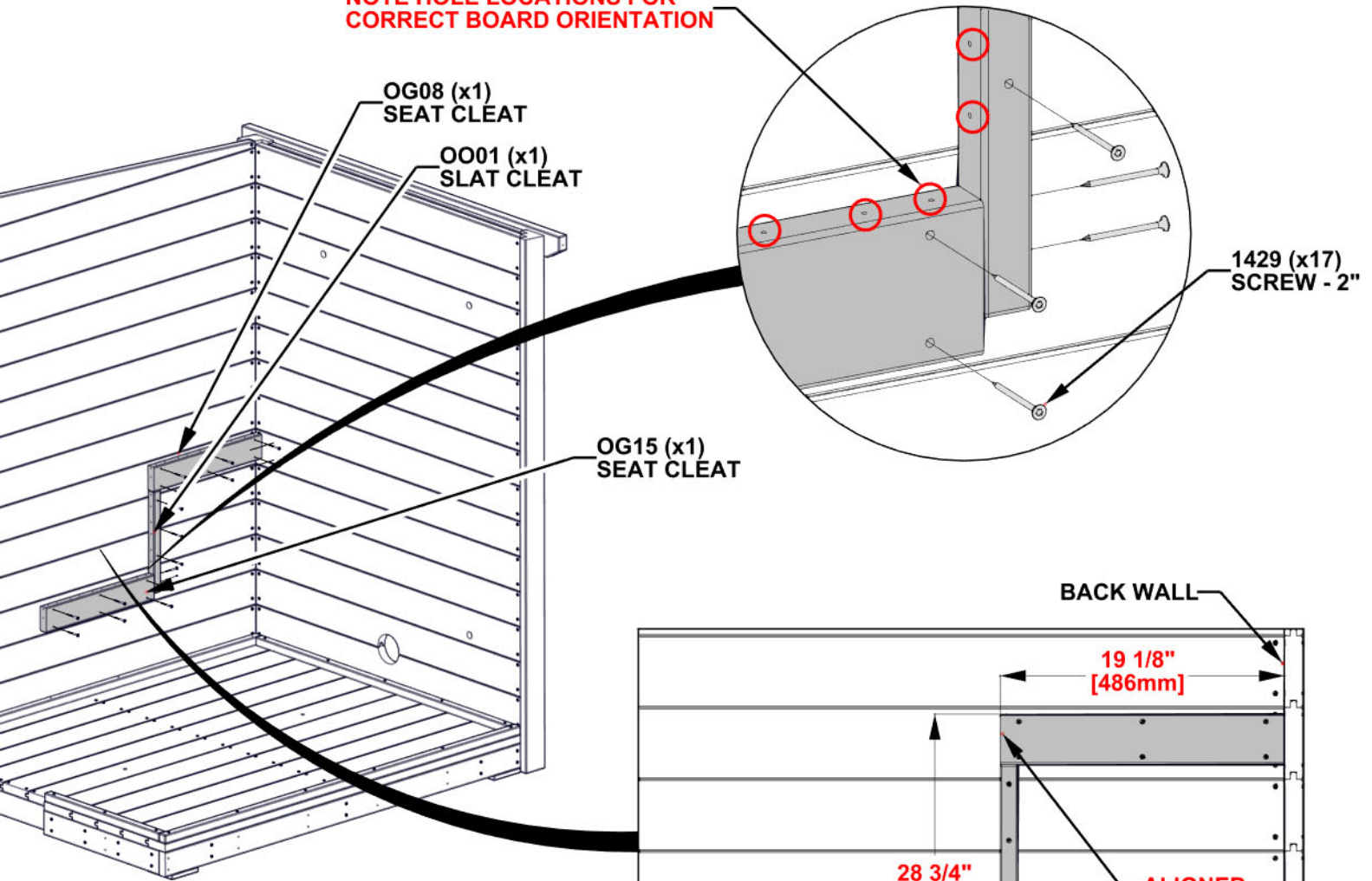

RIGHT SIDE AND FRONT WALL
HIDDEN FOR DETAIL

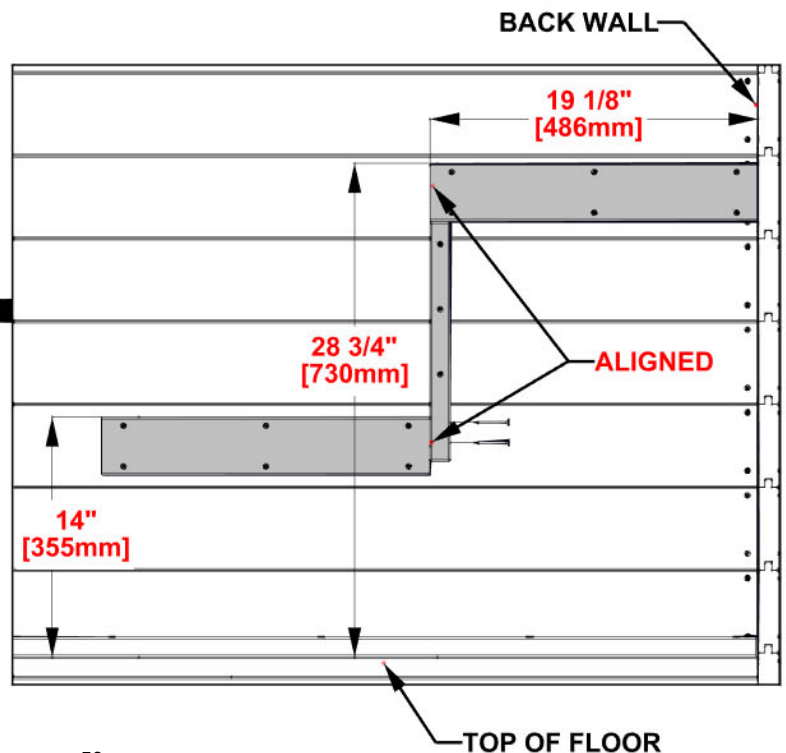

STEP 27 - BENCH ASSEMBLY

QTY	PART NUMBER	DESCRIPTION
10	H101429	SCREW TFH 8X2 SS-BLK



OG07 SEAT CLEAT - W4L22382
(x1) 1 3/16"x3 3/8"x45 7/16" (30x86x1154)

- CLEAT SHOULD BE CENTERED ON THE BACK WALL.
- ENSURE TOP OF SEAT CLEAT ARE FLUSH WITH CLEATS ON SIDE WALLS.
- USE DIMENSIONS SHOWN TO LOCATE WALL CLEAT.
- MEASUREMENT SHOWN IS TAKEN FROM INSIDE THE WALL.
- ATTACH AS SHOWN.

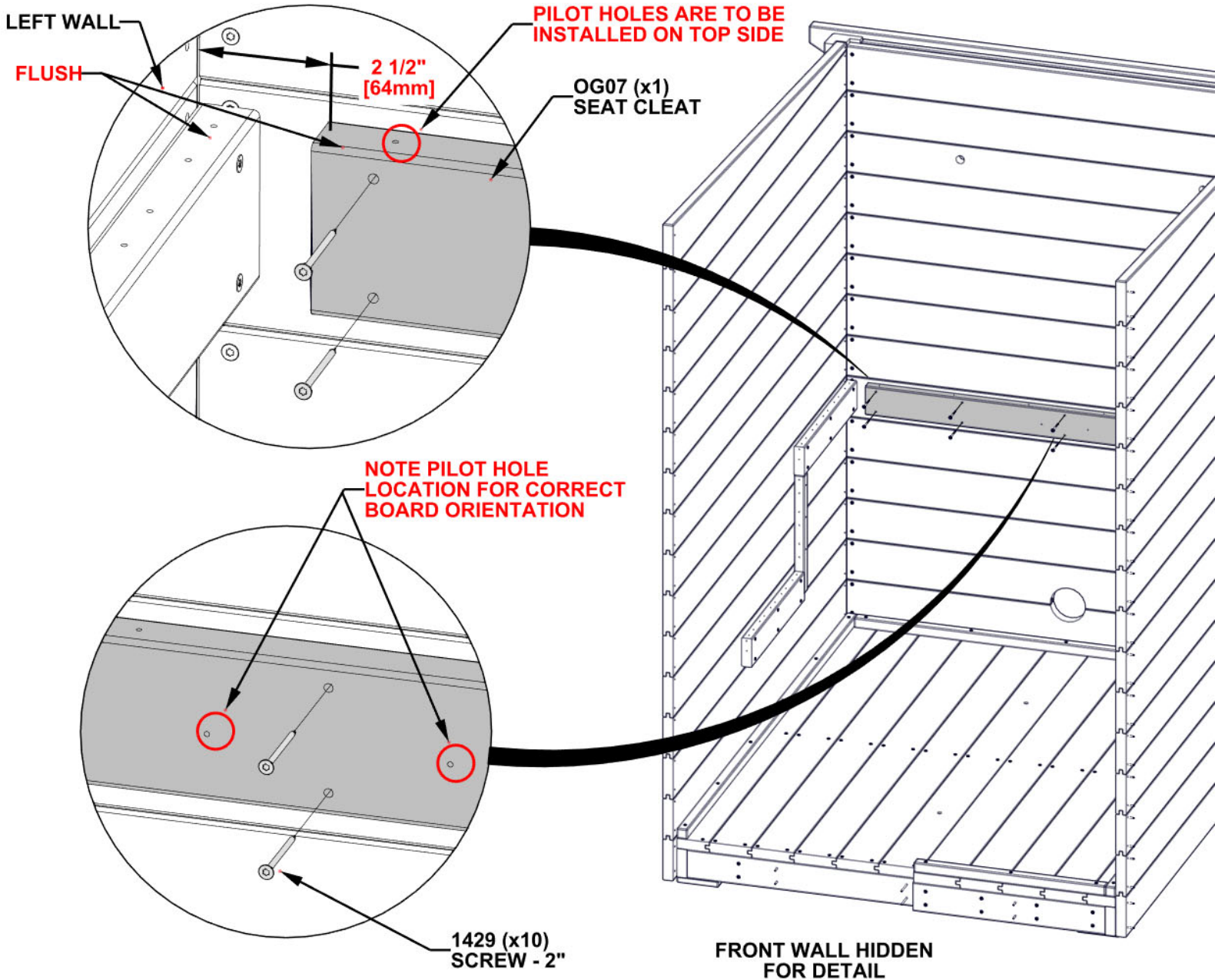

STEP 28 - ELECTRICAL



A6P01468 30mm SILCONE GROMMET
(x1)



A6P01489 SAUNA POWER WIRE
(x1)

- USE PROVIDED GROMMET FOR POWER CORD.
- LICENSE ELECTRICIAN IS REQUIRED FOR HEATER INSTALLATION.
- WILL NEED TO REMOVE CONDUIT FITTING TO FEED SAUNA POWER WIRE THROUGH GROMMET.

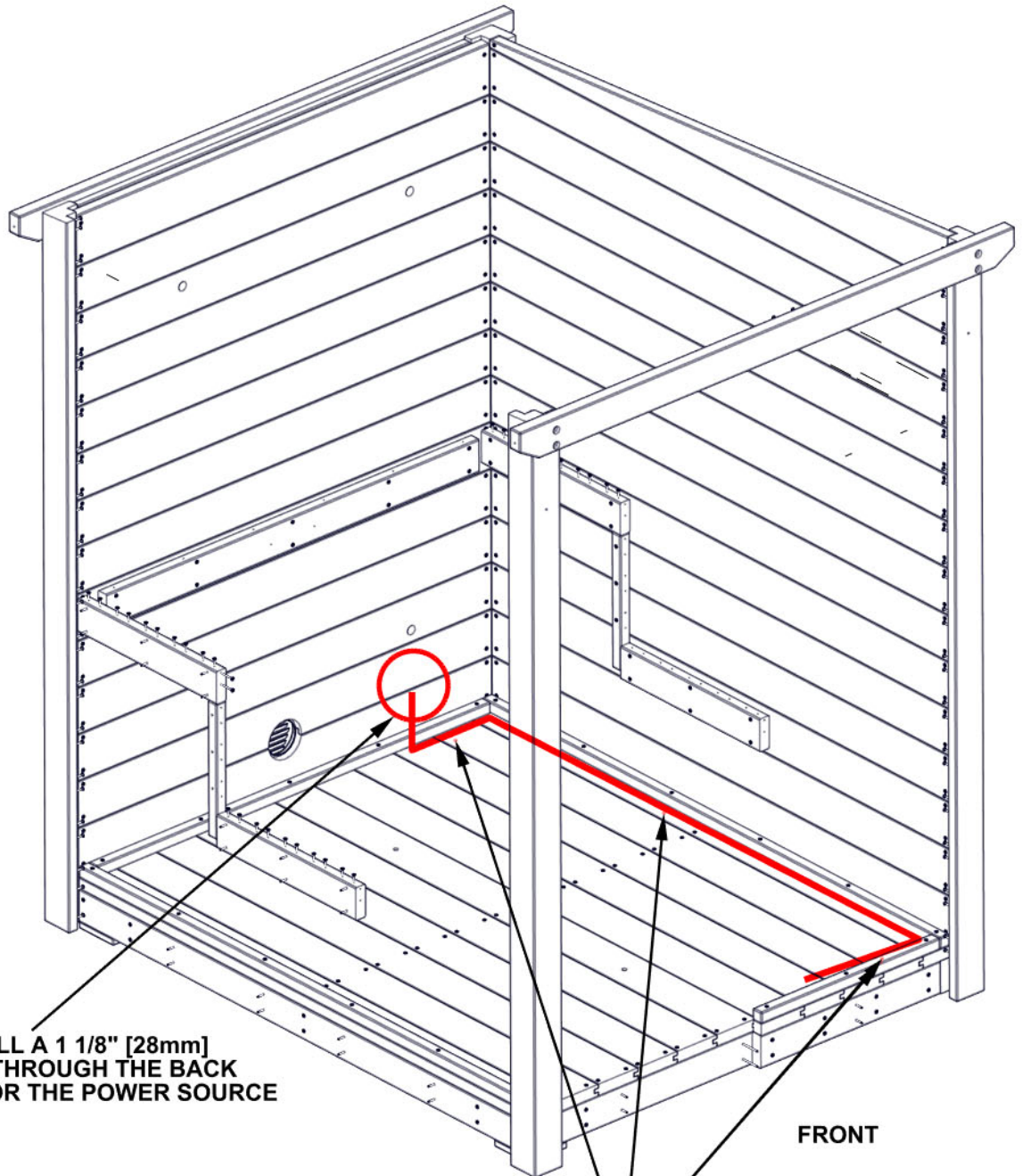

LOCATE AND DRILL A 1 1/8" [28mm]
DIAMETER HOLE THROUGH THE BACK
OF THE SAUNA FOR THE POWER SOURCE

RUN SAUNA POWER WIRE ALONG WALL.
ATTACH WITH PROVIDED WIRE CLAMPS.
LEAVE APROXIMATELY 18" [457mm] FREE
FROM THE SIDEWALL FOR HEATER.

STEP 29 - BENCH ASSEMBLY

QTY	PART NUMBER	DESCRIPTION
4	H101429	SCREW TFH 8X2 SS-BLK
8	H101443	SCREW TWH 8x1 1/2 SS-BLK

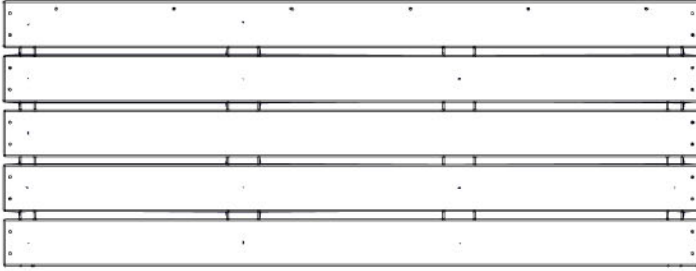

BA01 BENCH ASSEMBLY - W2A04918
(x1) 1 15/16"x19 1/8"x50 1/4" (50x486x1276)



OR01 SEAT UPRIGHT - W4L22406
(x2) 1 3/16"x2 3/8"x28 3/4" (30x60x730)



OR02 ANGLE BRACE - W4L21946
(x2) 1 3/16"x2 3/8"x10 7/8" (30x60x276)

- ALIGN PILOT HOLES AND ATTACH SEAT UPRIGHT TO BENCH ASSEMBLY AS SHOWN.
- THEN ALIGN PILOT HOLES IN ANGLE BRACE WITH PILOT HOLES IN SEAT UPRIGHT AND BENCH ASSEMBLY AND ATTACH.

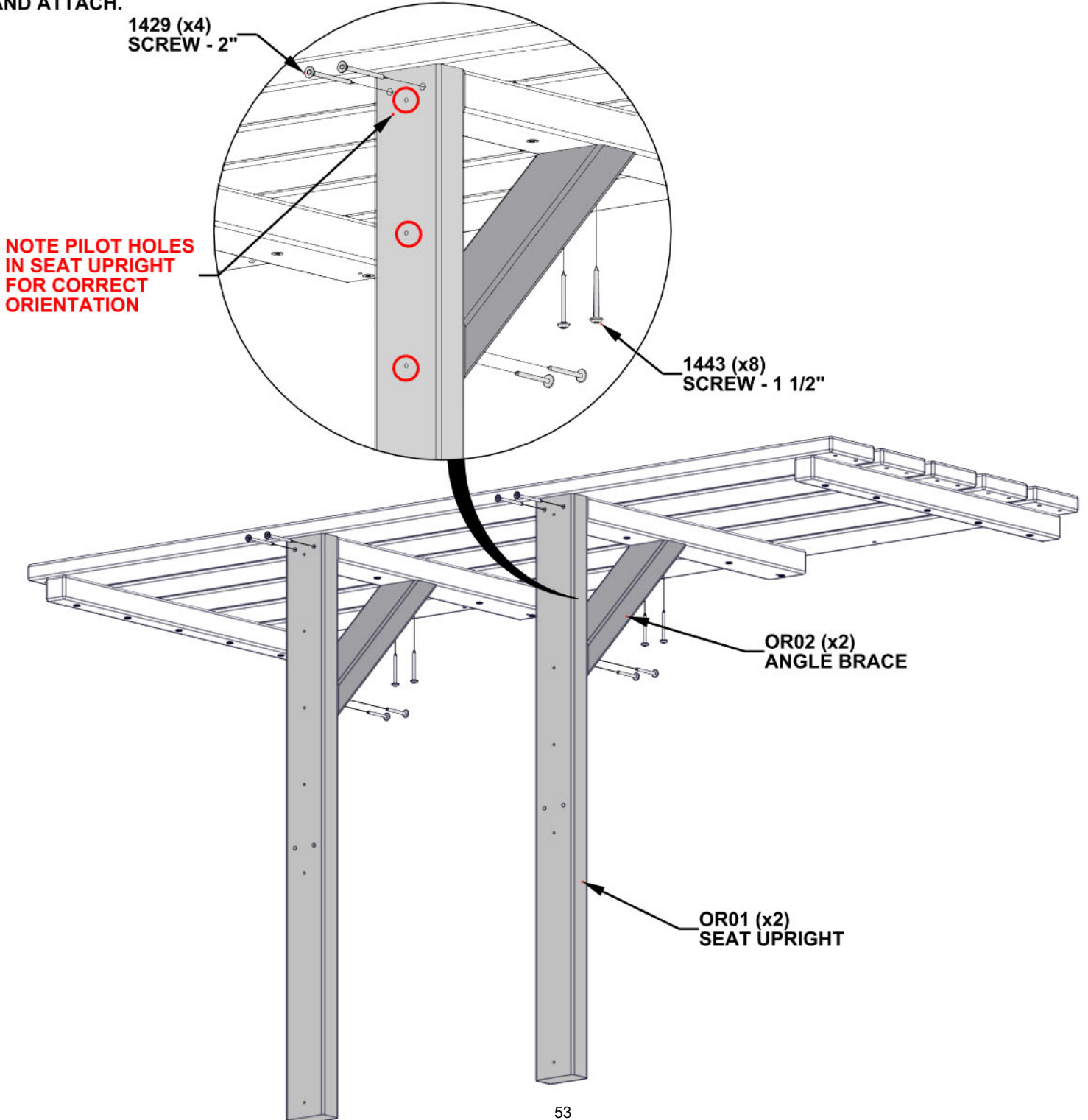

STEP 30 - BENCH ASSEMBLY

QTY	PART NUMBER	DESCRIPTION
26	H101428	SCREW TFH 8X1 3/4 SS-BLK

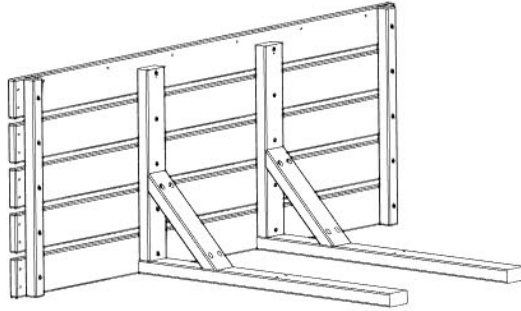

BENCH ASSEMBLY - STEP 29
(x1)

- ALIGN THROUGH HOLES IN BENCH ASSEMBLY WITH PILOT HOLES IN SEAT CLEATS AND ATTACH AS SHOWN.

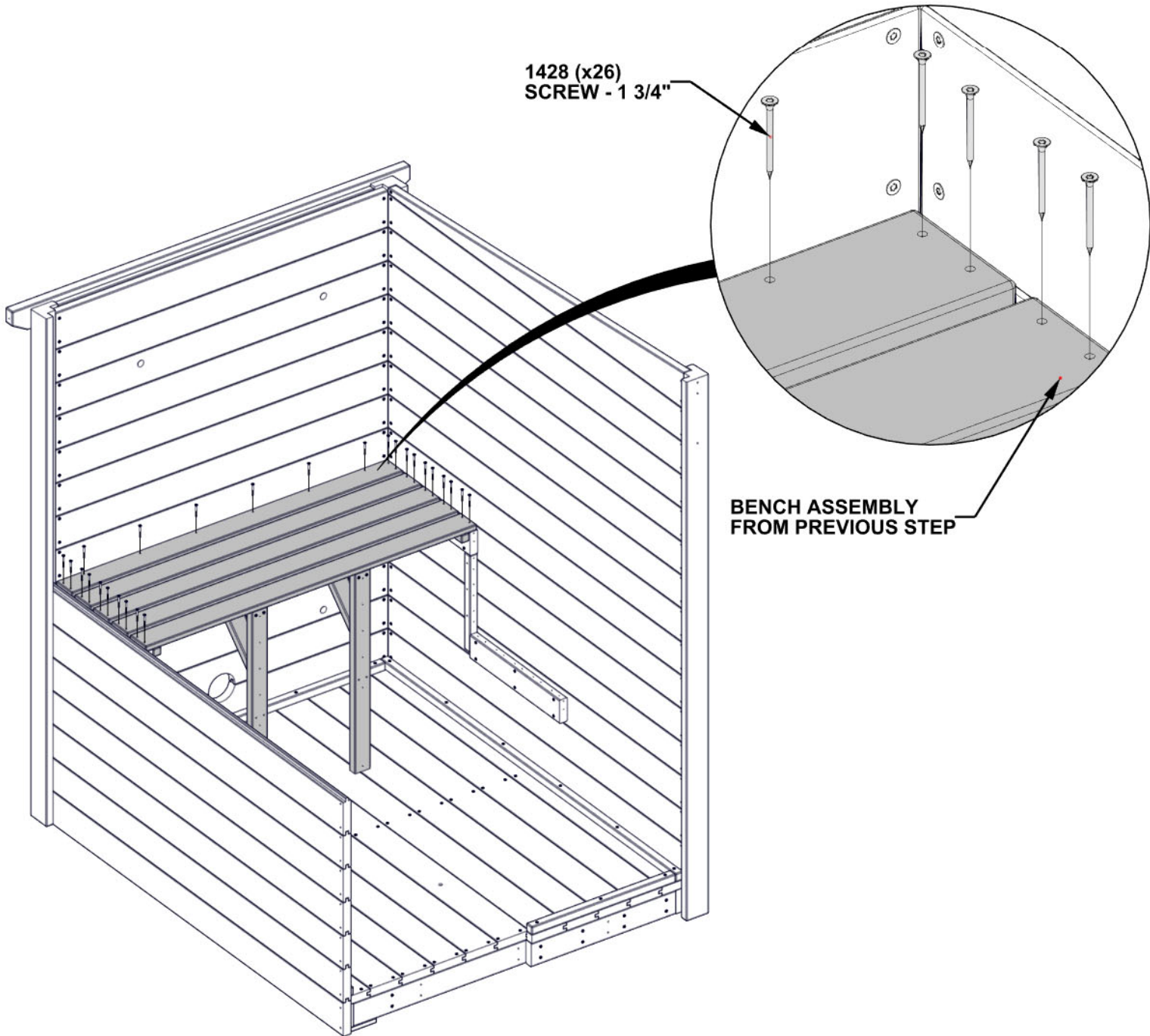

FRONT WALL AND PARTIAL LEFT SIDE
HIDDEN FOR DETAIL

STEP 31 - BENCH ASSEMBLY

QTY	PART NUMBER	DESCRIPTION
8	H101438	SCREW TWH 8x3/4 SS-BLK

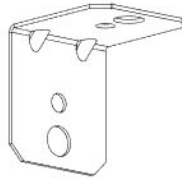

A4M00555 L BRACKET BLK
(x4)

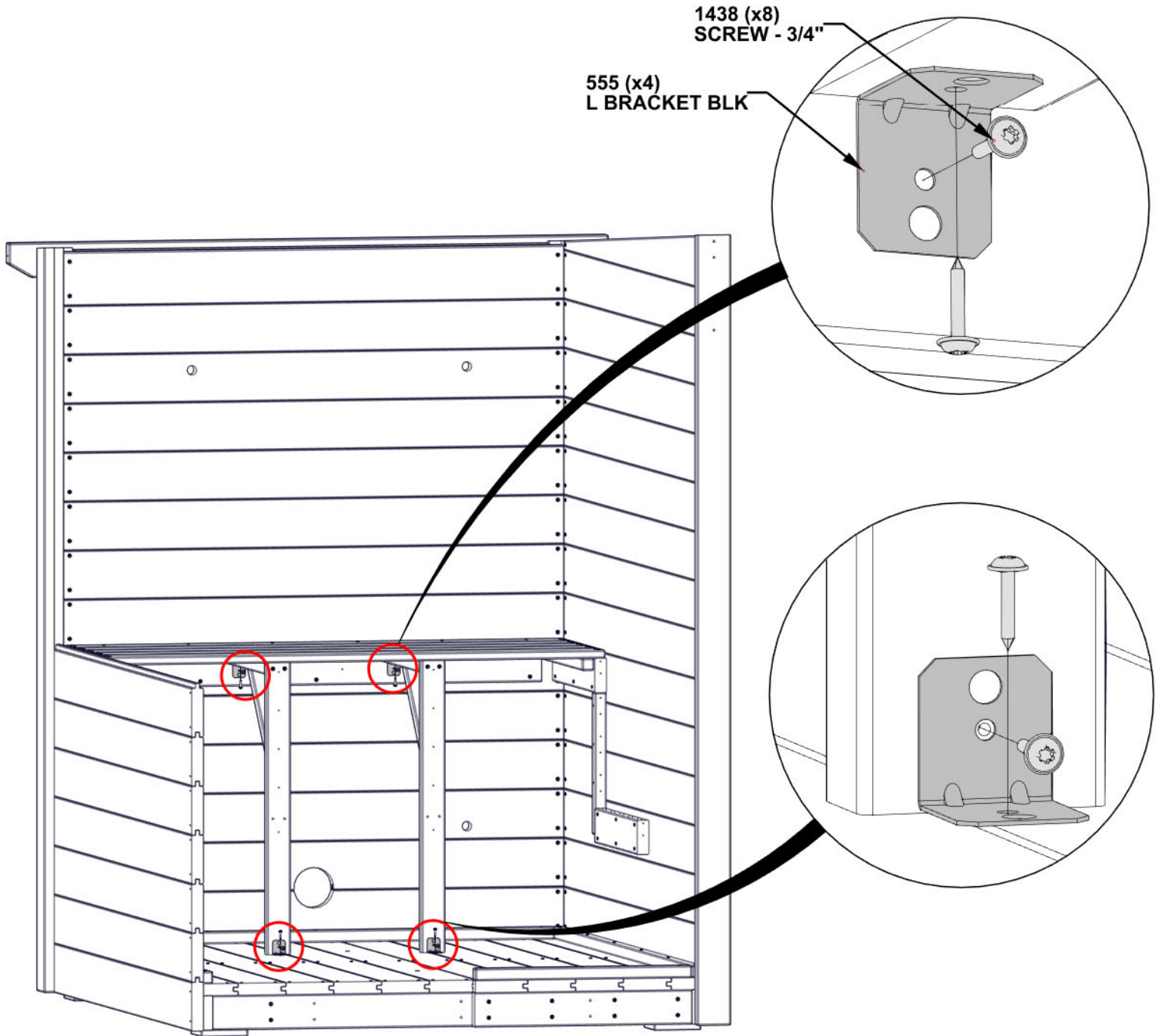

1438 (x8)
SCREW - 3/4"

555 (x4)
L BRACKET BLK

FRONT WALL AND PARTIAL LEFT SIDE
HIDDEN FOR DETAIL

STEP 32 - BENCH ASSEMBLY

QTY	PART NUMBER	DESCRIPTION
4	H101429	SCREW TFH 8X2 SS-BLK
8	H101443	SCREW TWH 8x1 1/2 SS-BLK

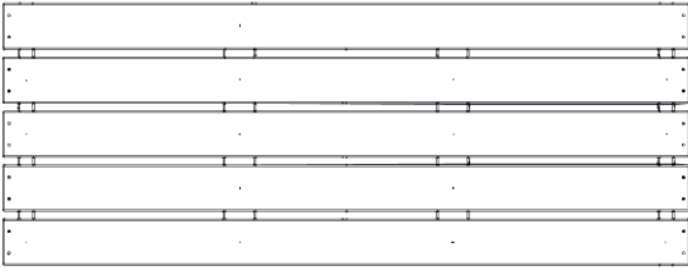

BA02 BENCH ASSEMBLY - W2A04920
(x1) 1 15/16"x19 1/8"x50 1/4" (50x486x1276)



OR03 BENCH UPRIGHT - W4L22405
(x2) 1 3/16"x2 3/8"x14" (30x60x355)



OR02 ANGLE BRACE - W4L21946
(x2) 1 3/16"x2 3/8"x10 7/8" (30x60x276)

- ALIGN PILOT HOLES AND ATTACH SEAT UPRIGHT TO BENCH ASSEMBLY AS SHOWN.
- THEN ALIGN PILOT HOLES IN ANGLE BRACE WITH PILOT HOLES IN SEAT UPRIGHT AND BENCH ASSEMBLY AND ATTACH.

1429 (x4)
SCREW - 2"

**NOTE PILOT HOLES
IN SEAT UPRIGHT
FOR CORRECT
ORIENTATION**

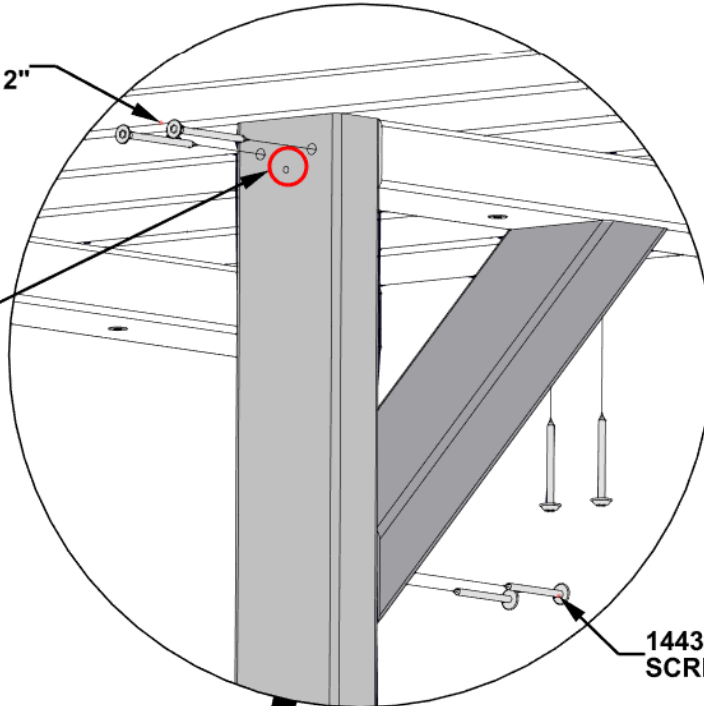

1443 (x8)
SCREW - 1 1/2"

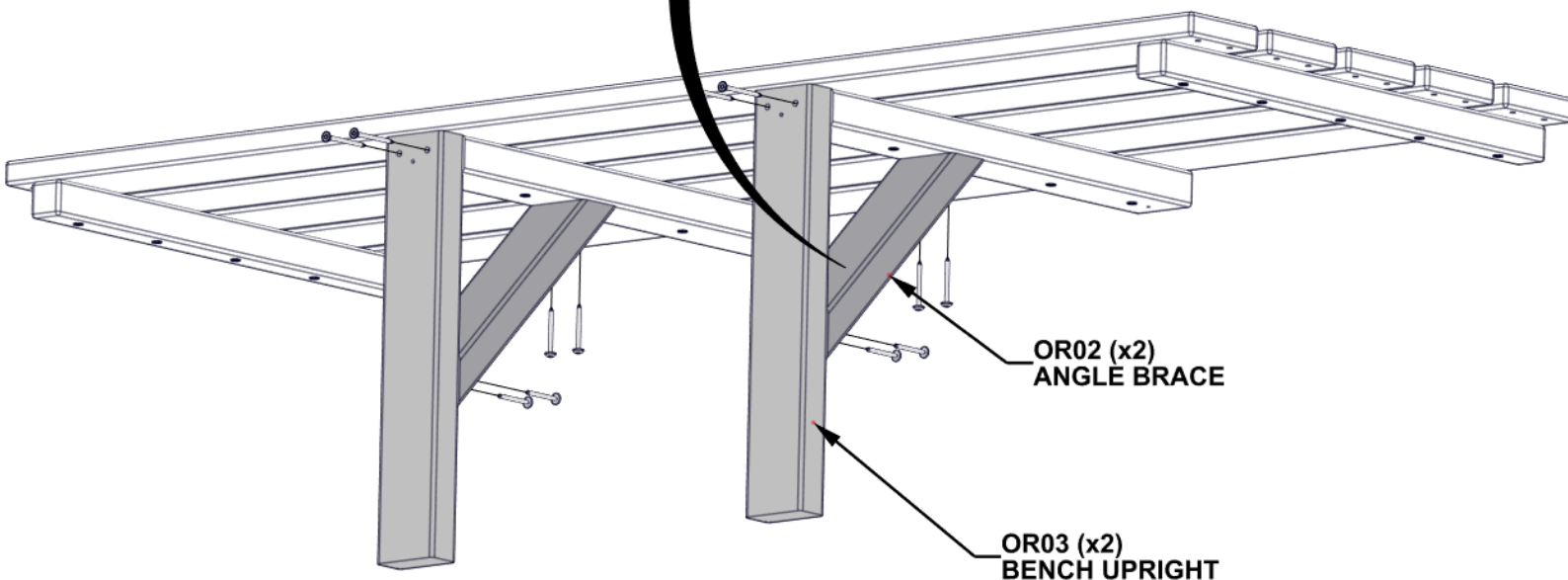

OR02 (x2)
ANGLE BRACE

OR03 (x2)
BENCH UPRIGHT

STEP 33 - BENCH ASSEMBLY

QTY	PART NUMBER	DESCRIPTION
20	H101428	SCREW TFH 8X1 3/4 SS-BLK
4	H101429	SCREW TFH 8X2 SS-BLK

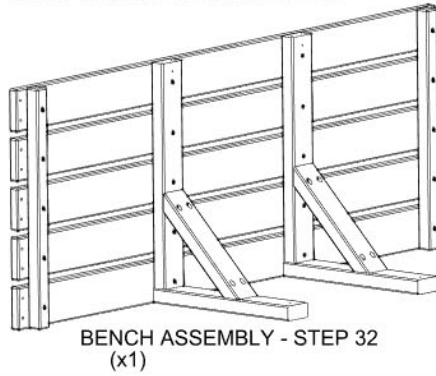

- ALIGN THROUGH HOLES IN BENCH ASSEMBLY WITH PILOT HOLES IN SEAT CLEATS AND ATTACH AS SHOWN.
- ALIGN THROUGH HOLES IN PREVIOUSLY INSTALLED BENCH UPRIGHTS WITH PILOT HOLES IN BENCH ASSEMBLY.

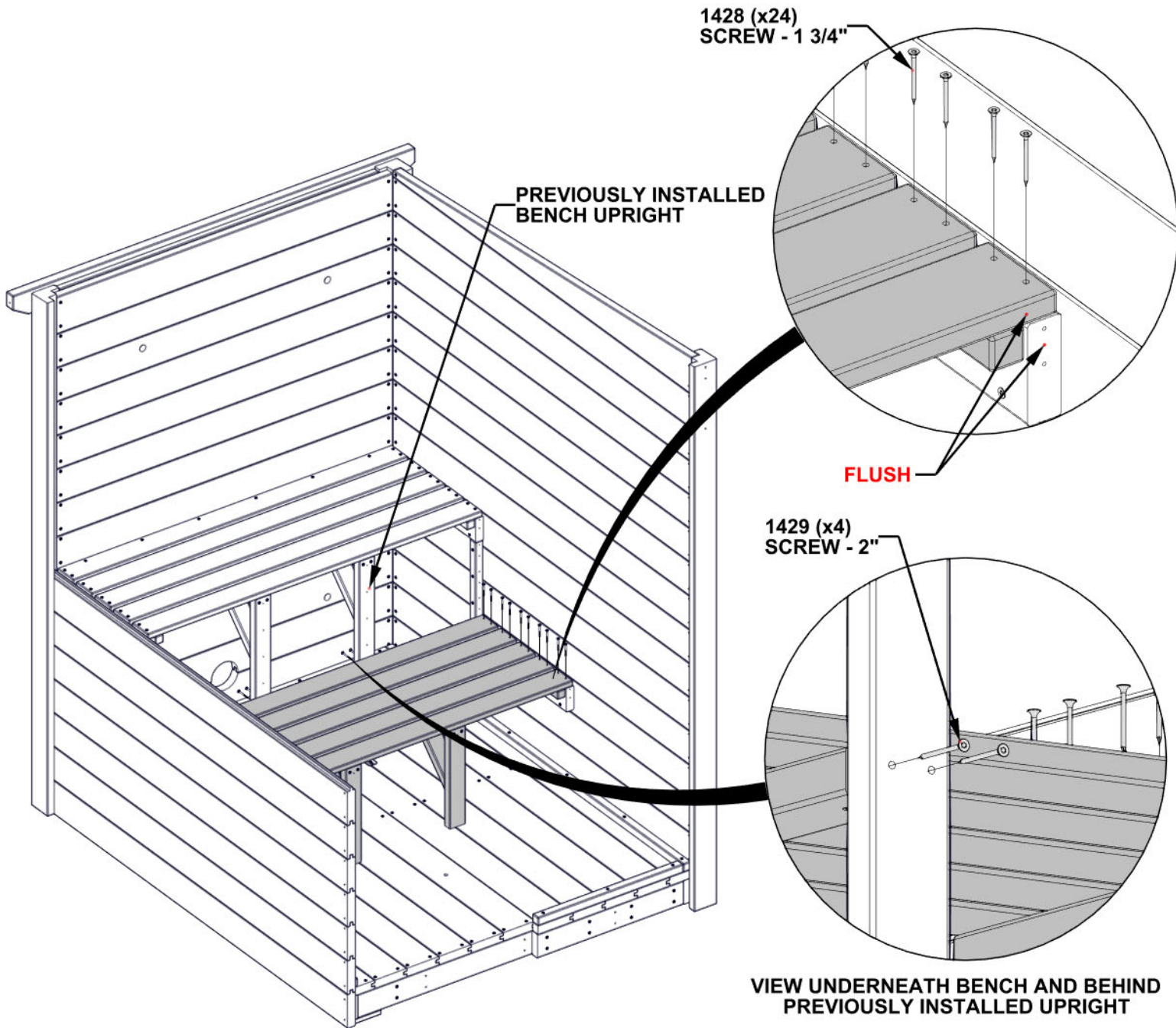

FRONT WALL AND PARTIAL LEFT SIDE
HIDDEN FOR DETAIL

STEP 34 - BENCH ASSEMBLY

QTY	PART NUMBER	DESCRIPTION
8	H101438	SCREW TWH 8x3/4 SS-BLK

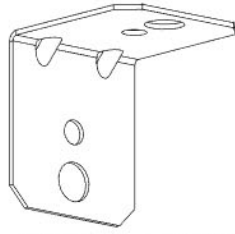

A4M00555 L BRACKET BLK
(x4)

- ALIGN BRACKETS WITH PILOT HOLES IN BACKS OF UPRIGHTS AND ATTACH AS SHOWN.

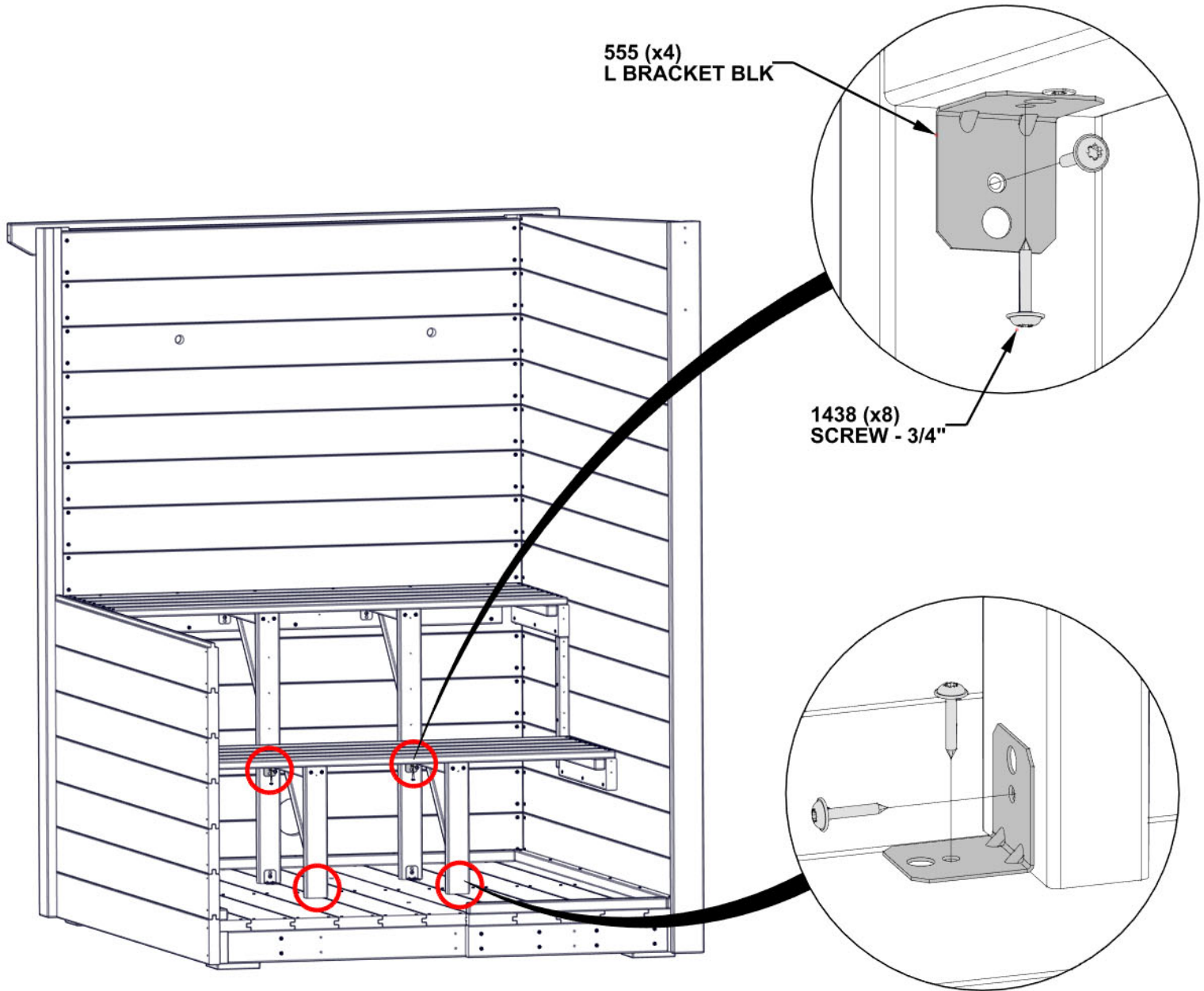

FRONT WALL AND PARTIAL LEFT SIDE
HIDDEN FOR DETAIL

STEP 35 - BENCH ASSEMBLY

QTY	PART NUMBER	DESCRIPTION
12	H101430	SCREW TFH 8X2 1/4 SS-BLK



W01 SEAT TRIM - W4L22383
(x2) 1 9/16"x3 3/8"x50 1/4" (40x86x1276)

- ALIGN THROUGH HOLES IN SEAT TRIM WITH PILOT HOLES IN UPRIGHTS AND CLEATS AND ATTACH

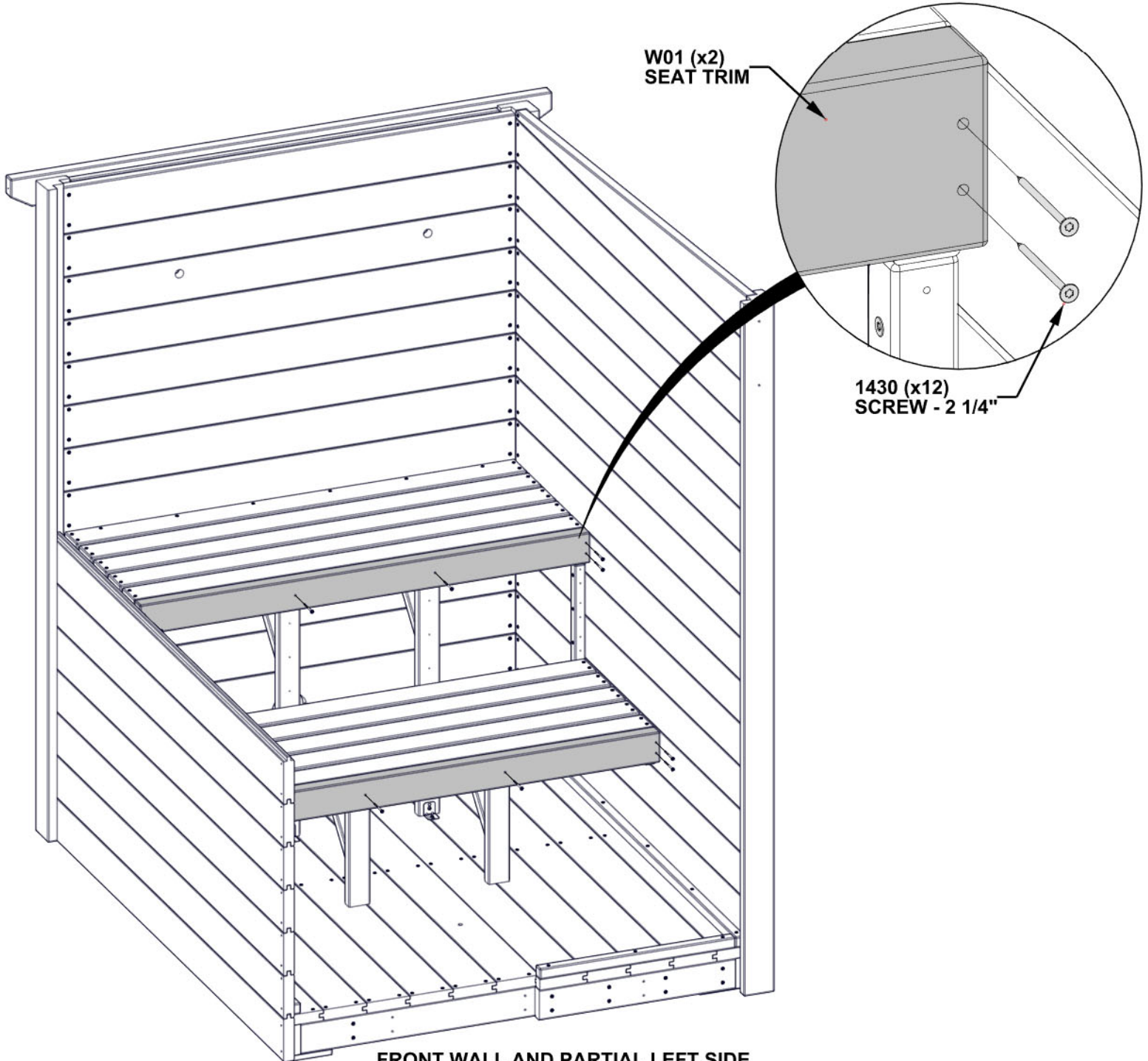

FRONT WALL AND PARTIAL LEFT SIDE
HIDDEN FOR DETAIL

STEP 36 - HEATER ASSEMBLY

QTY	PART NUMBER	DESCRIPTION
12	H101427	SCREW TFH 8X1 1/2 SS-BLK



N01 HEATER MOUNT - W4L22411
(x2) 5/8"x2 3/8"x16 9/16" (16x60x420)

- FLUSH N01 BOARD AGAINST RIGHT SIDE WALL.
- USE DIMENSIONS SHOWN TO LOCATE HEATER MOUNT BOARDS AND ATTACH AS SHOWN.

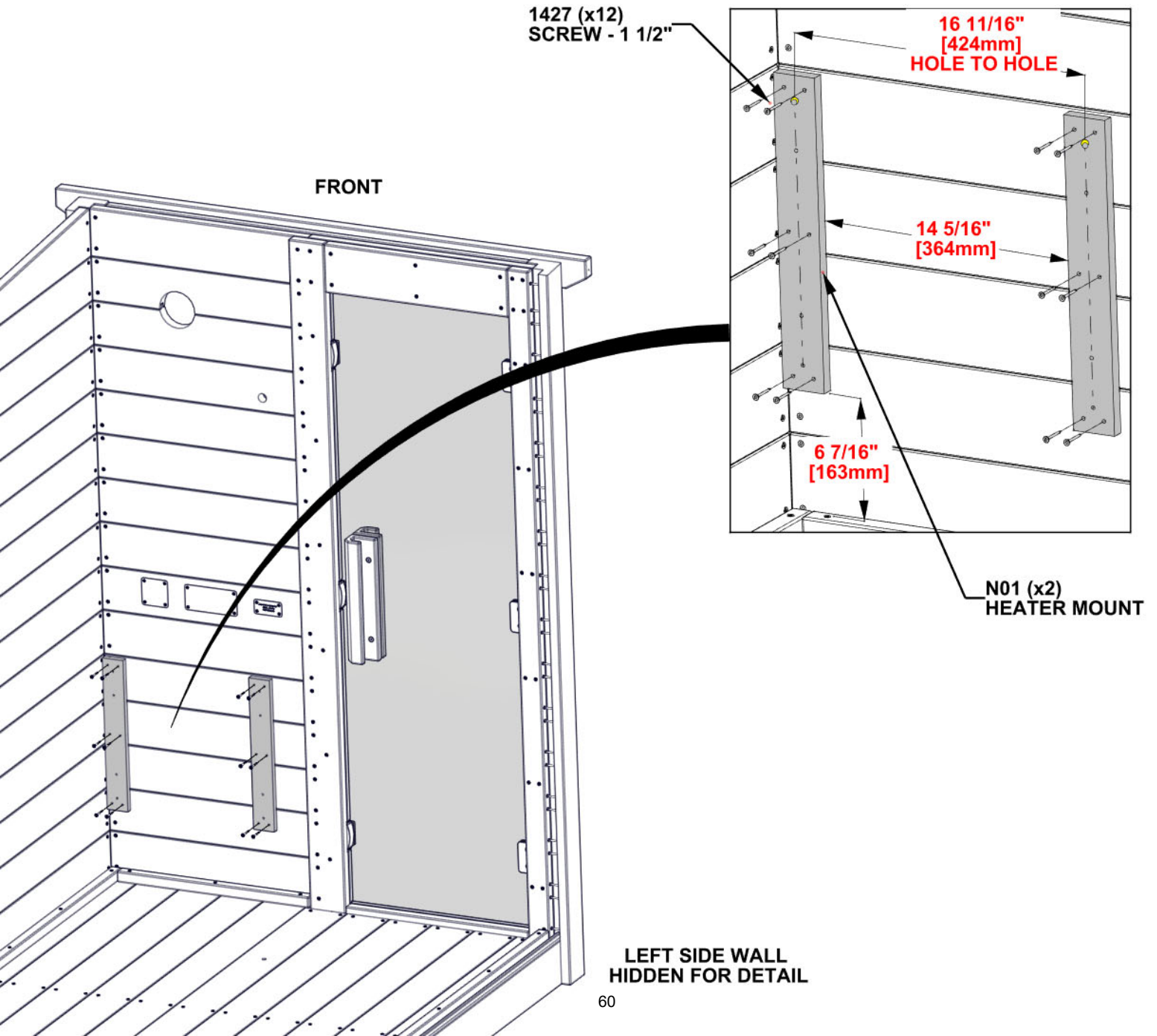

STEP 37 - HEATER GUARD

QTY	PART NUMBER	DESCRIPTION
15	H101428	SCREW TFH 8X1 3/4 SS-BLK



OO03 HEATER GUARD BOARD - W4L22038
(x1) 1 3/16"x1 3/16"x16 1/8" (30x30x410)



OO04 HEATER GUARD BOARD - W4L22035
(x1) 1 3/16"x1 3/16"x16 1/8" (30x30x410)



NR04 HEATER GUARD BOARD - W4L22412
(x5) 13/16"x2 3/8"x15 3/4" (20x60x400)

- ALIGN HOLES IN NR04 WITH PILOT HOLES IN OO03 AND OO04.

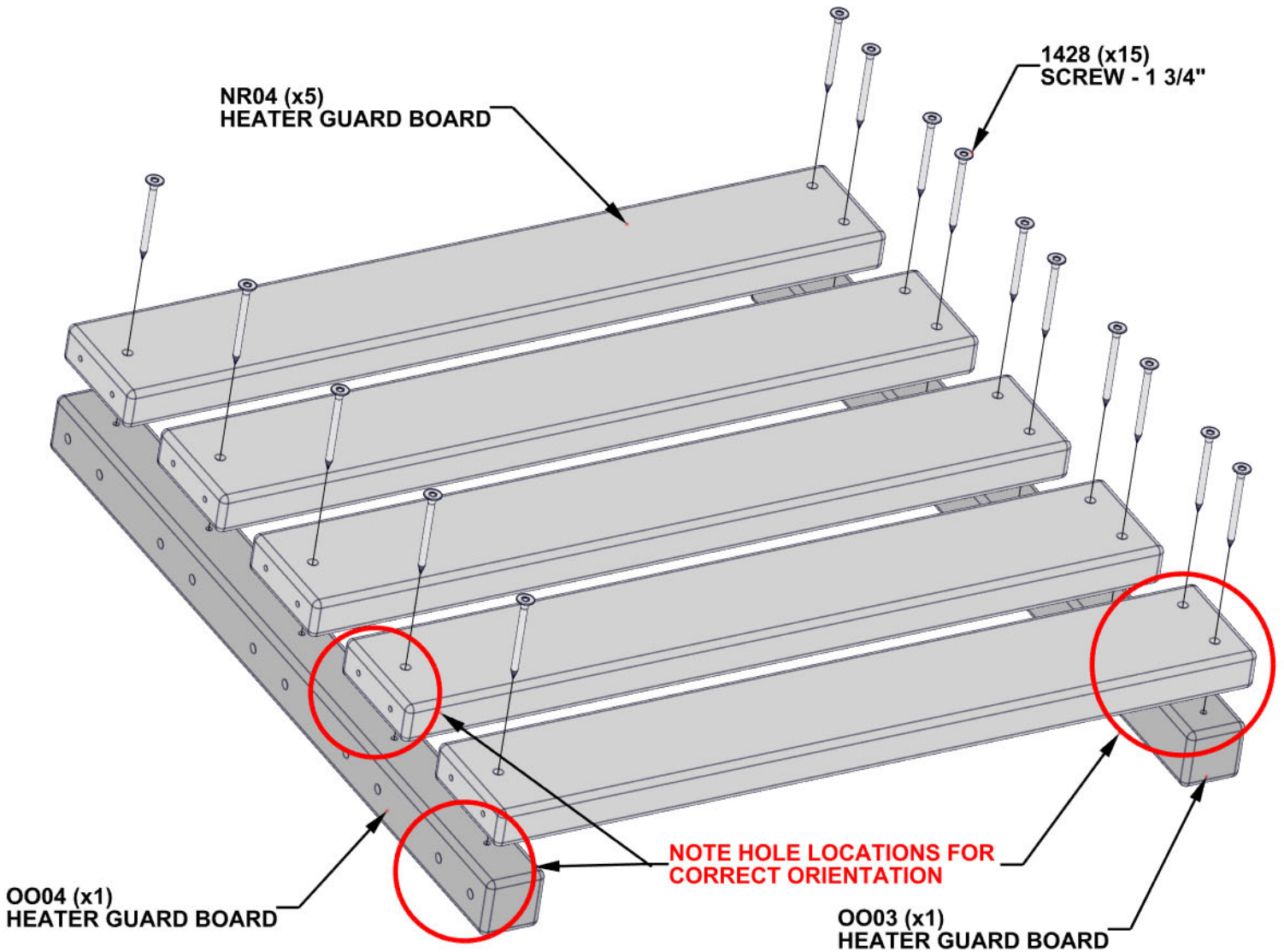

STEP 38 - HEATER GUARD

QTY	PART NUMBER	DESCRIPTION
30	H101428	SCREW TFH 8X1 3/4 SS-BLK



NR03 HEATER GUARD BOARD - W4L22413
(x5) 13/16"x2 3/8"x21 3/16" (20x60x538)



OO03 HEATER GUARD BOARD - W4L22038
(x1) 1 3/16"x1 3/16"x16 1/8" (30x30x410)

- ALIGN THROUGH HOLES WITH PILOT HOLES AND ATTACH AS SHOWN.

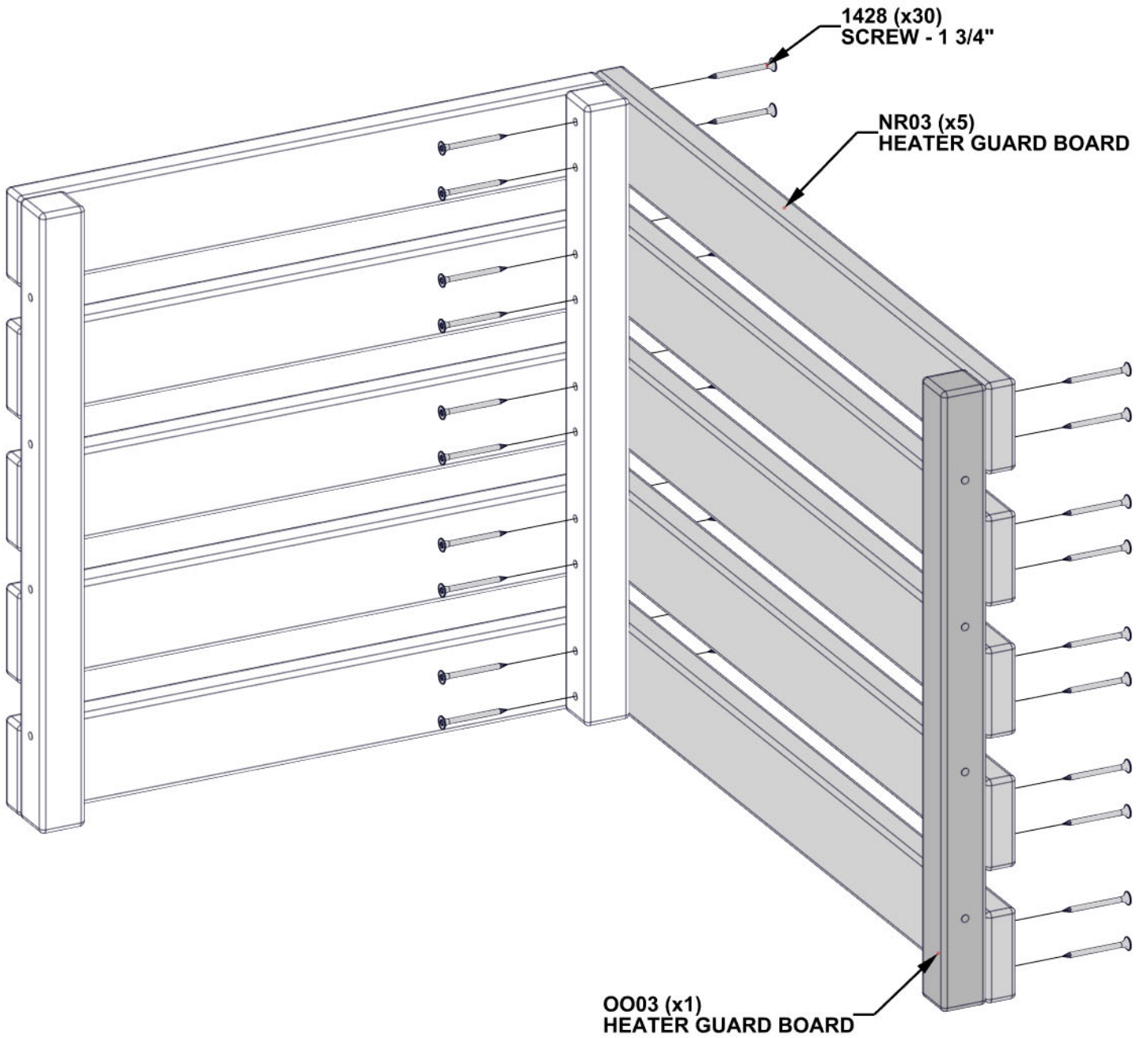

STEP 39 - HEATER GUARD

QTY	PART NUMBER	DESCRIPTION
8	H101429	SCREW TFH 8X2 SS-BLK

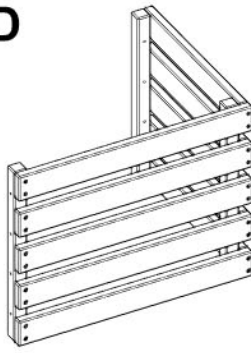

HEATER GUARD ASSEMBLY - STEP 38
(x1)

- POSITION HEATER GUARD ASSEMBLY AS SHOWN AND ATTACH.

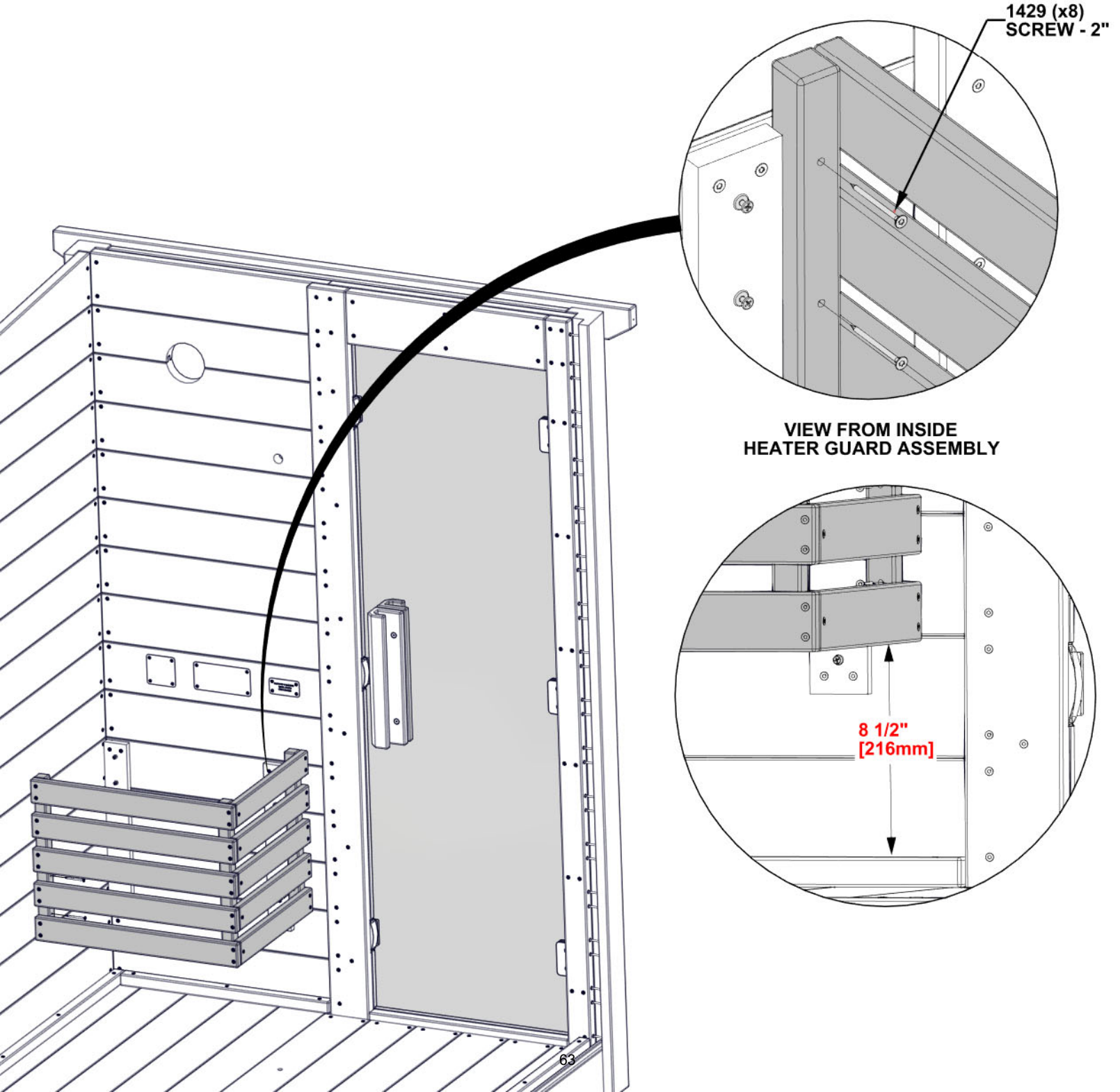

STEP 40 - HEATER

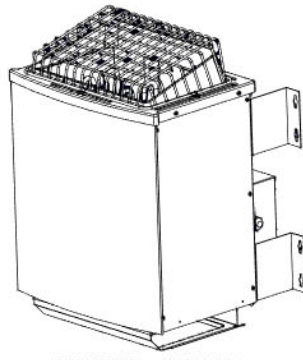

9250253 HEATER
(x1)

QTY	PART NUMBER	DESCRIPTION
8	H101468	SCREW RAISED HEAD 8x1"

- **CAUTION: IMPROPER INSTALLATION OF THE HEATER COULD CAUSE HEATER TO FALL CAUSING BURNS OR OTHER INJURIES.**
- **DANGER! TURN OFF POWER TO THE HEATER AT THE BREAKER BEFORE BEGINNING INSTALLATION OR PERFORMING ANY MAINTENANCE. FAILURE TO TURN OFF THE POWER CAN RESULT IN ELECTROCUTION AND EVEN DEATH.**
- **ONCE FINISHED WITH THE SAUNA BUILD, A LICENSED ELECTRICIAN IS REQUIRED FOR HEATER INSTALLATION - SEE HEATER INSTRUCTIONS.**
- **INSERT SCREWS INTO PILOT HOLES IN HEATER GUARD SPACER BOARDS.**
- **HANG HEATER ONTO SCREWS, ENSURING ALL 8 SCREWS ARE ALIGNED INTO THE SLOTS IN THE HEATER AS SHOWN.**

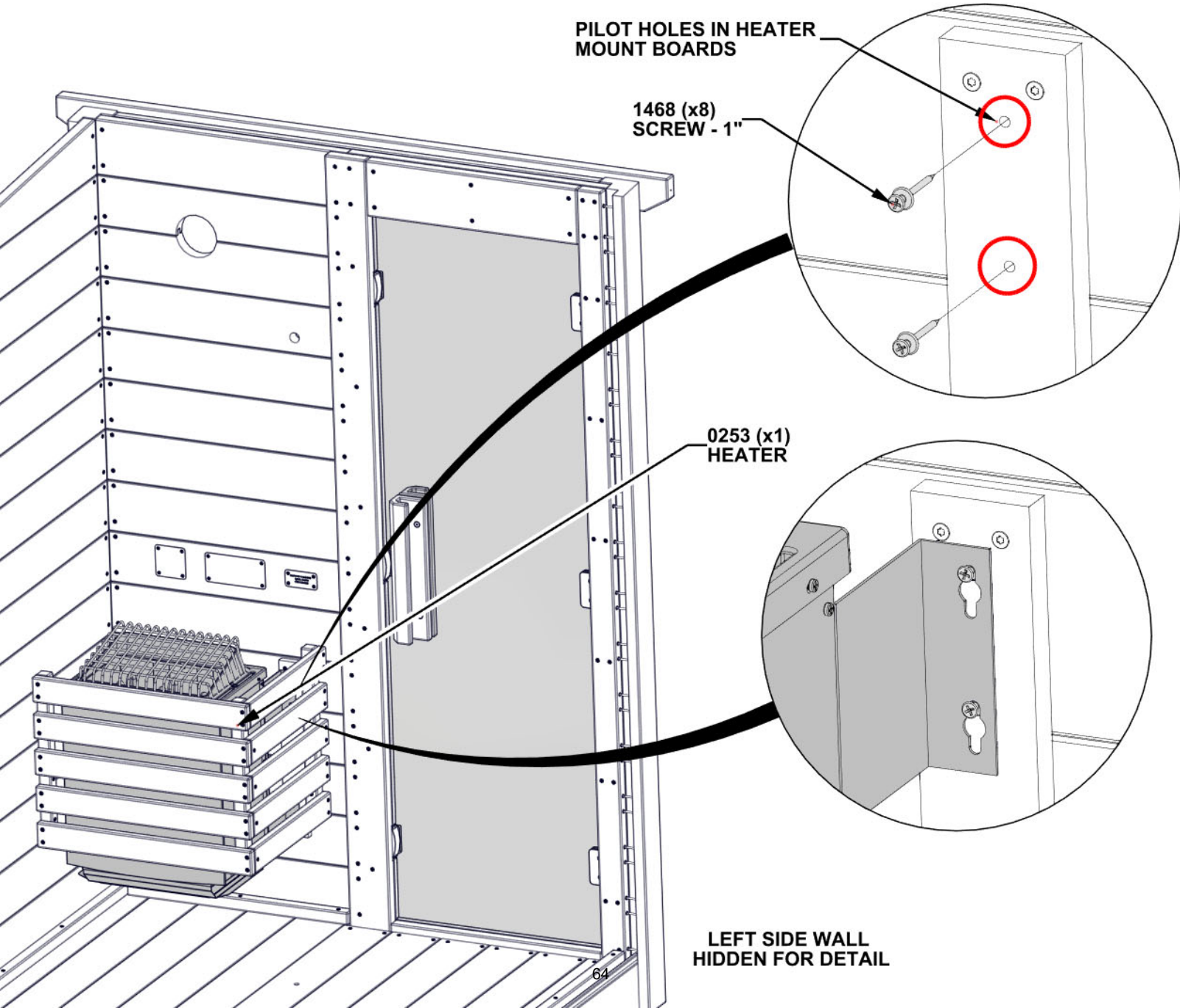

PILOT HOLES IN HEATER
MOUNT BOARDS

1468 (x8)
SCREW - 1"

0253 (x1)
HEATER

LEFT SIDE WALL
HIDDEN FOR DETAIL

STEP 41 - ROOF ASSEMBLY

QTY	PART NUMBER	DESCRIPTION
2	H100405	WASHER LOCK EXT BLK
2	H100487	LAG SCREW WH BLK

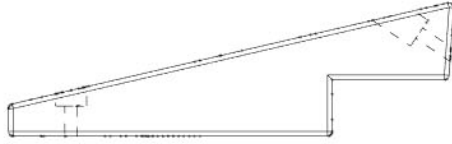

W03 ANGLE BRACE - W4L22409
(x2) 1 15/16"x3 3/8"x11 1/4" (50x86x285)

- ALIGN PILOT HOLES.

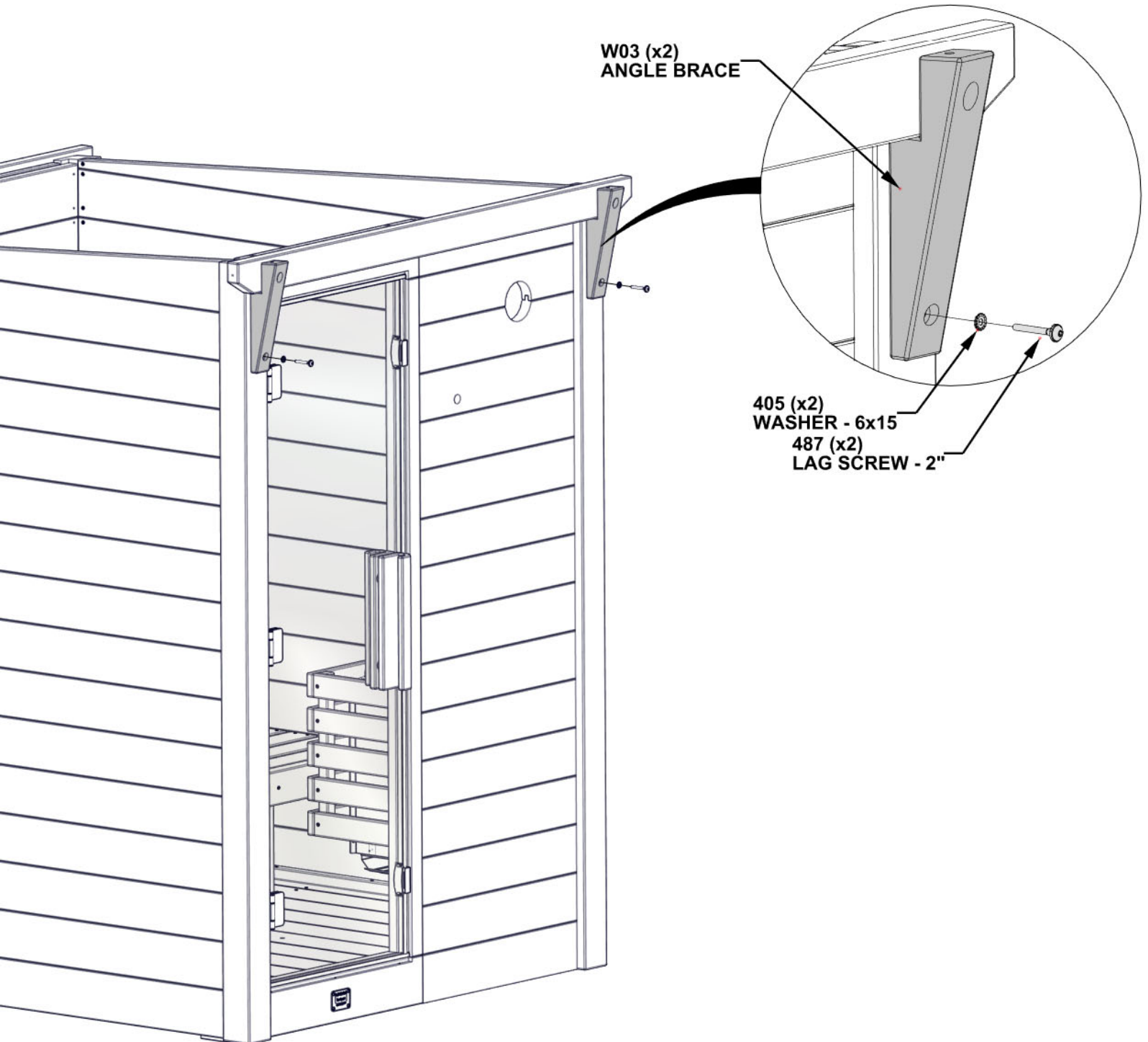

STEP 42 - ROOF ASSEMBLY

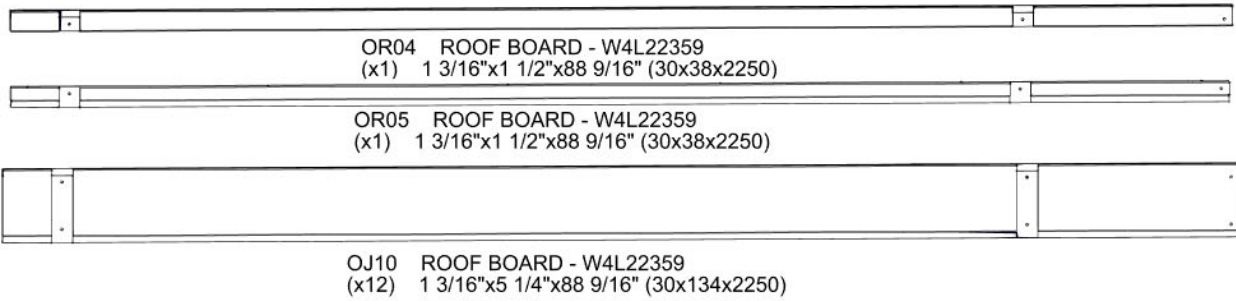

- LAY BOARDS ON TOP AS SHOWN, EVENLY SPACED. DO NOT FASTEN AT THIS TIME.

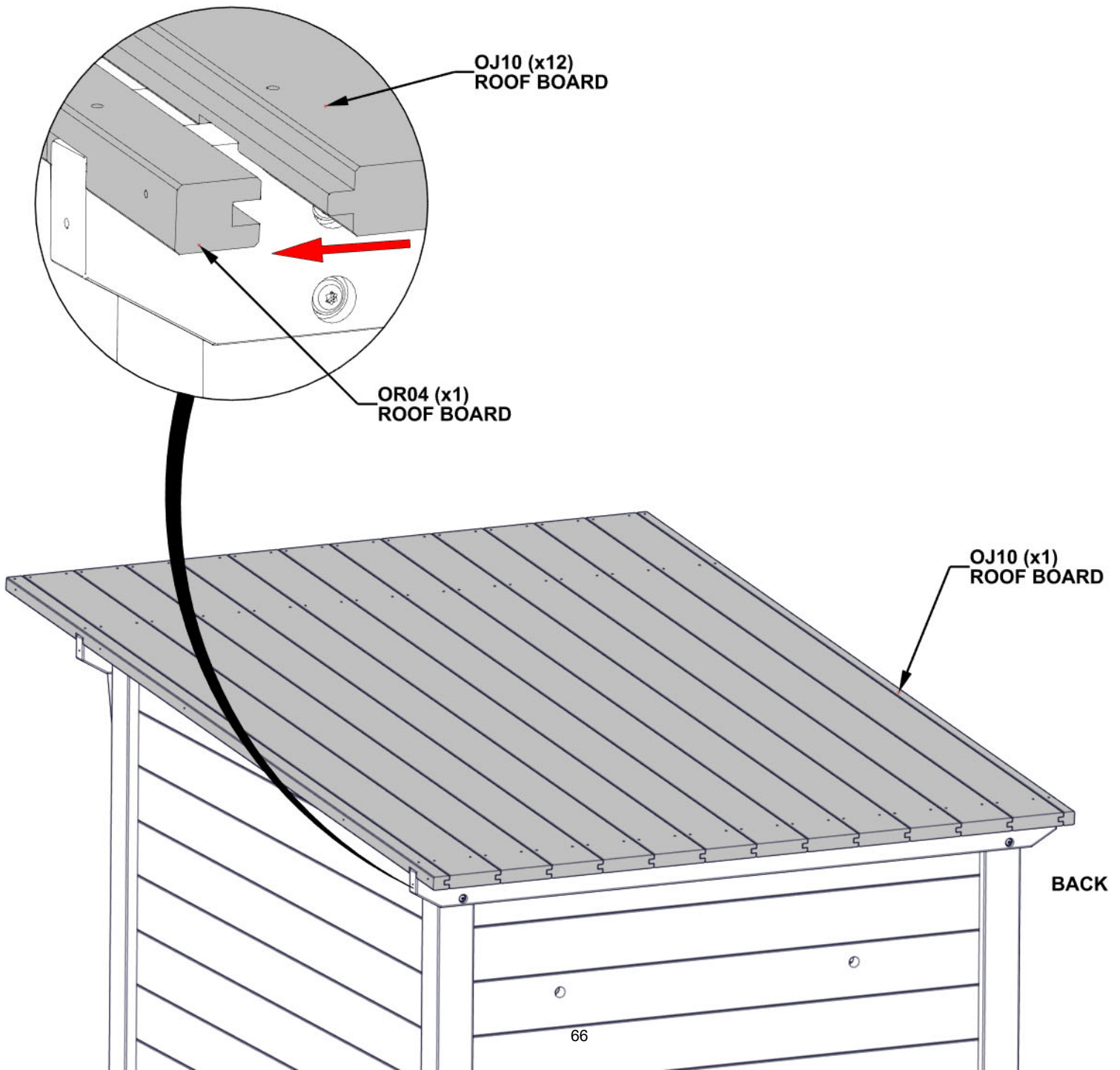

STEP 43 - ROOF ASSEMBLY

QTY	PART NUMBER	DESCRIPTION
2	H101030	SCREW CONFIRMAT BLK
6	H101429	SCREW TFH 8X2 SS-BLK



NG02 ROOF TRIM - W4L22360
(x1) 13/16"x3 3/8"x89 3/8" (20x86x2270)

- ALIGN THROUGH HOLES WITH PILOT HOLES.
- USE DIMENSIONS SHOWN TO LOCATE NG02 AND ATTACH AS SHOWN.

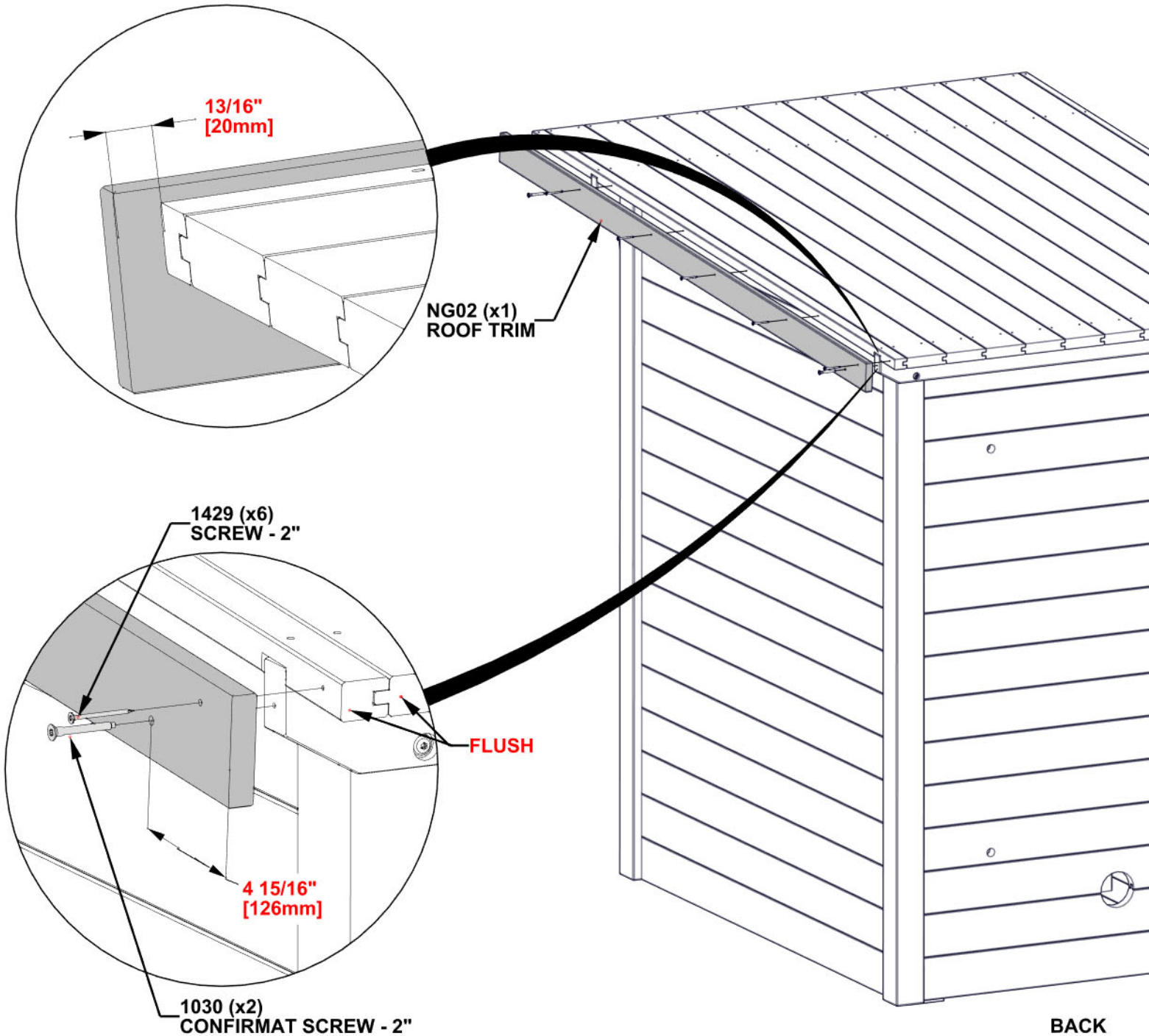

STEP 44 - ROOF ASSEMBLY

QTY	PART NUMBER	DESCRIPTION
2	H101030	SCREW CONFIRMAT BLK
6	H101429	SCREW TFH 8X2 SS-BLK



NG02 ROOF TRIM - W4L22360
(x1) 13/16"x3 3/8"x89 3/8" (20x86x2270)

- ALIGN THROUGH HOLES WITH PILOT HOLES.
- USE DIMENSIONS SHOWN TO LOCATE NG02 AND ATTACH AS SHOWN.

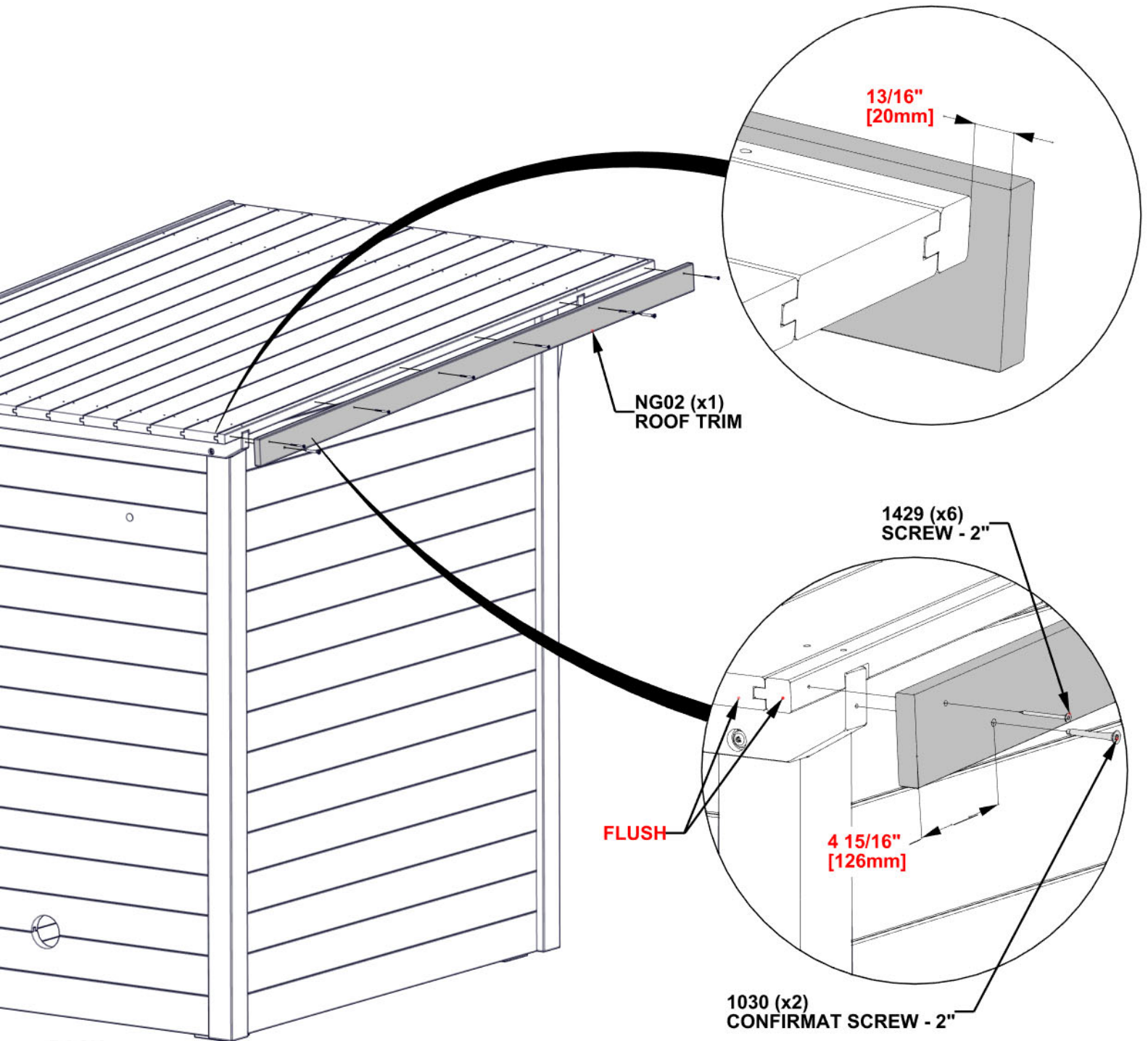

STEP 45 - ROOF ASSEMBLY

QTY	PART NUMBER	DESCRIPTION
52	H10142	SCREW TFH 8X

- ADJUST ROOF BOARDS AS NEEDED TO BE FLUSH BOTH AT FRONT AND BACK.
- ATTACH AS SHOWN.

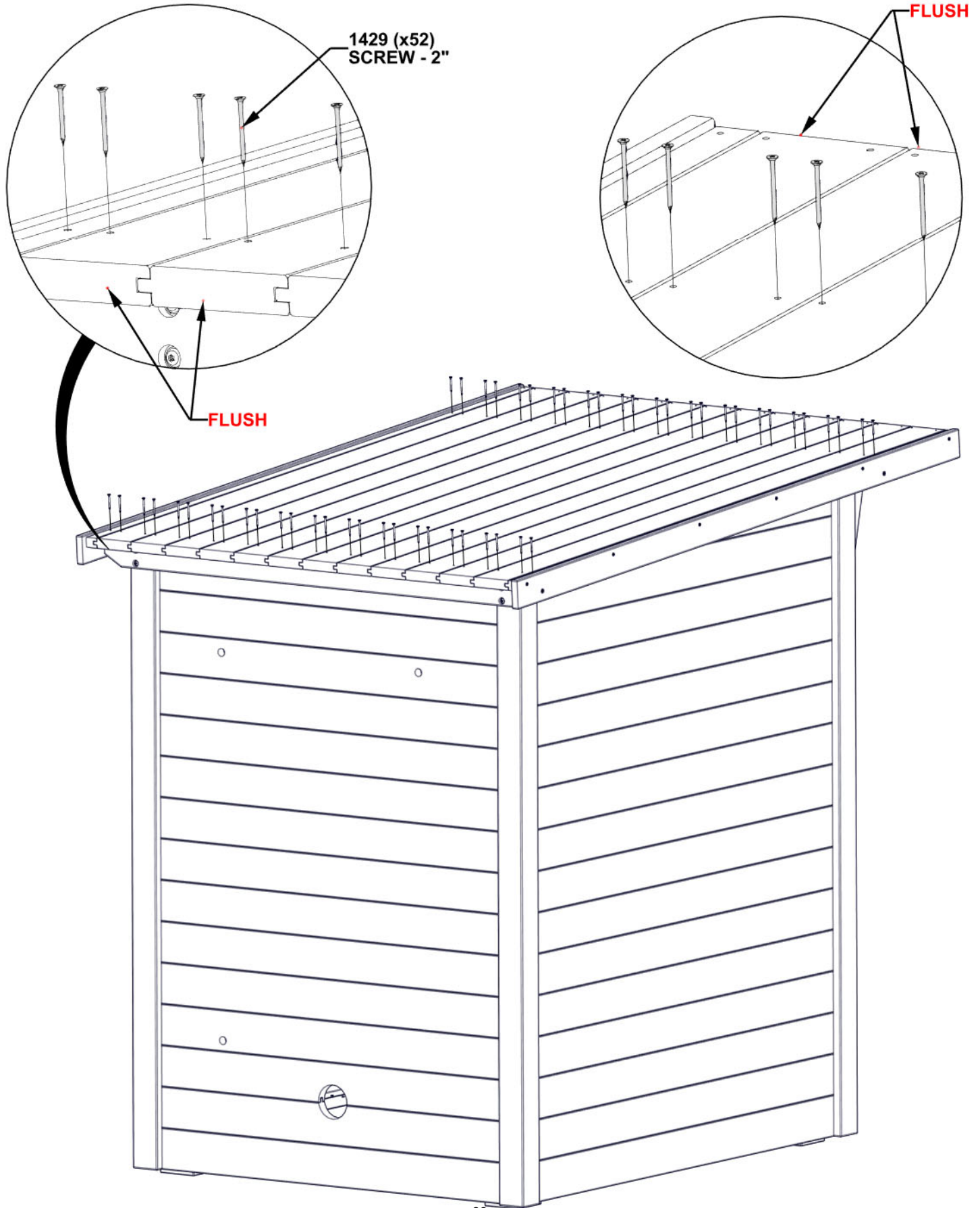

STEP 46 - ROOF ASSEMBLY

QTY	PART NUMBER	DESCRIPTION
12	H101428	SCREW TFH 8X1 3/4 SS-BLK

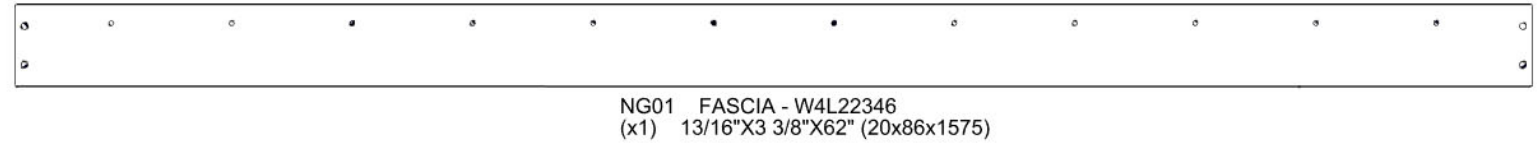
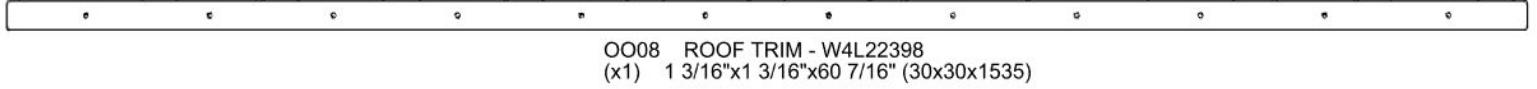

- ALIGN THROUGH HOLES WITH PILOT HOLES AND ATTACH AS SHOWN.
- NOTE PILOT HOLES ON OO08 TO FACE UPWARDS.

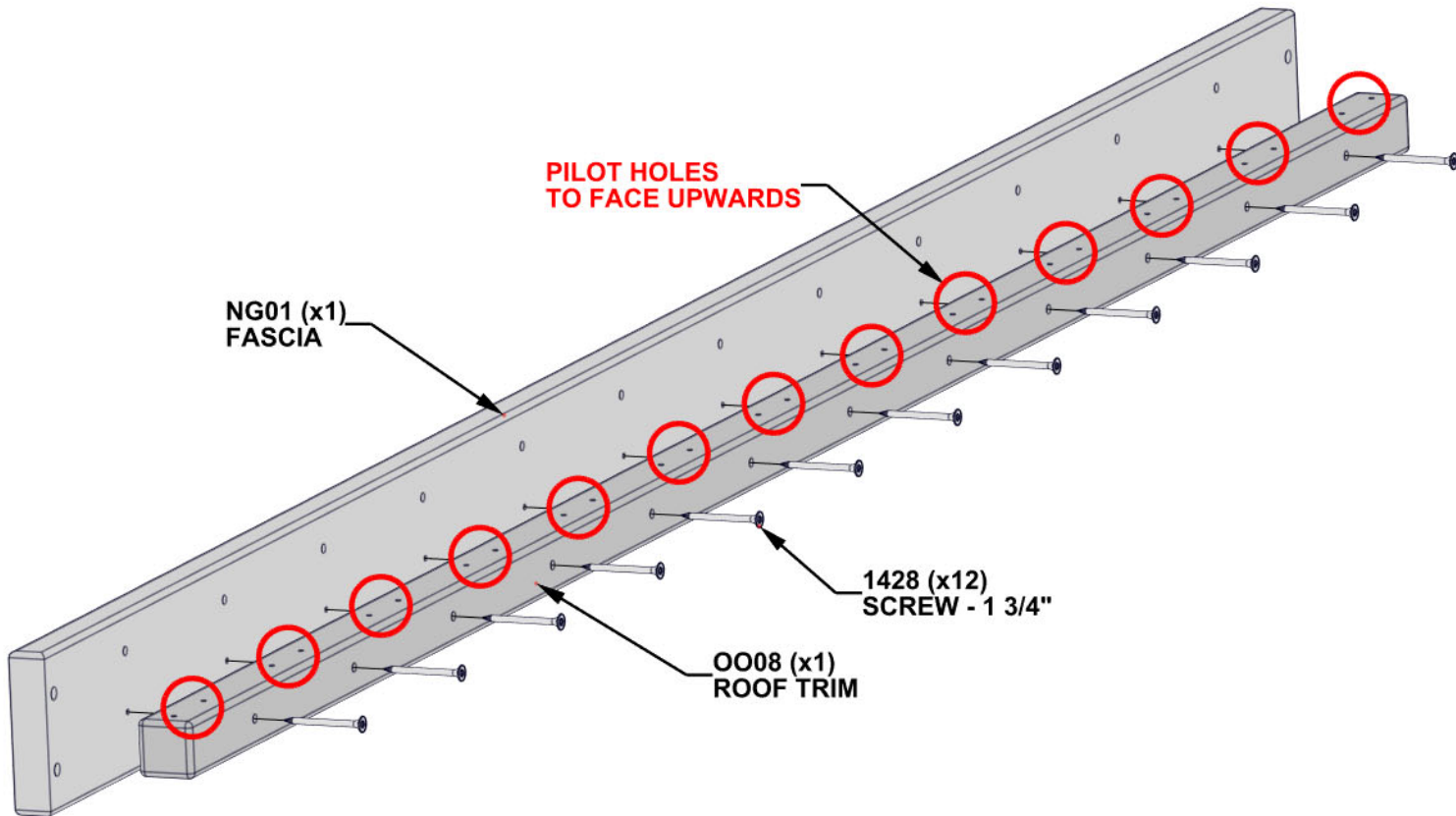

STEP 47 - ROOF ASSEMBLY

QTY	PART NUMBER	DESCRIPTION
4	H101030	SCREW CONFIRMAT BLK
12	H101429	SCREW TFH 8X2 SS-BLK

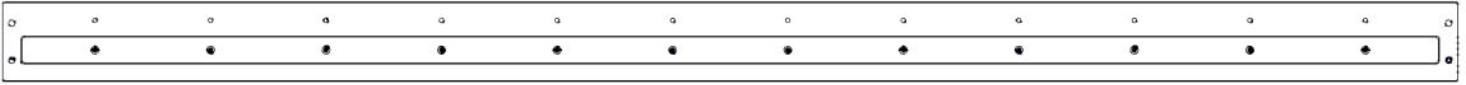

FASCIA ASSEMBLY - PREVIOUS STEP
(x1)

- ALIGN THROUGH HOLES WITH PILOT HOLES AND ATTACH AS SHOWN.

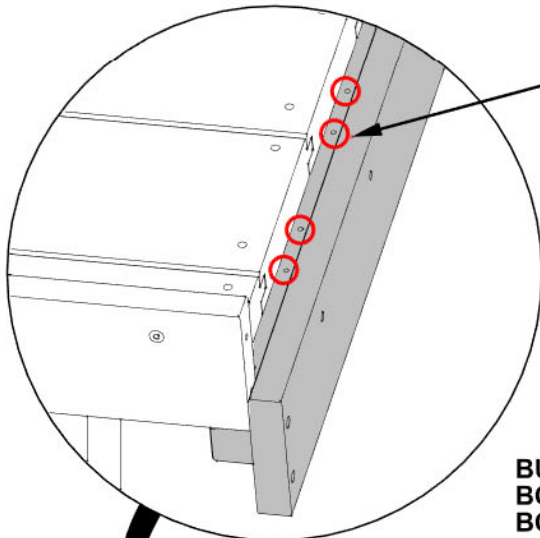

TOP VIEW

NOTE PILOT HOLES LOCATION FOR PROPER ORIENTATION

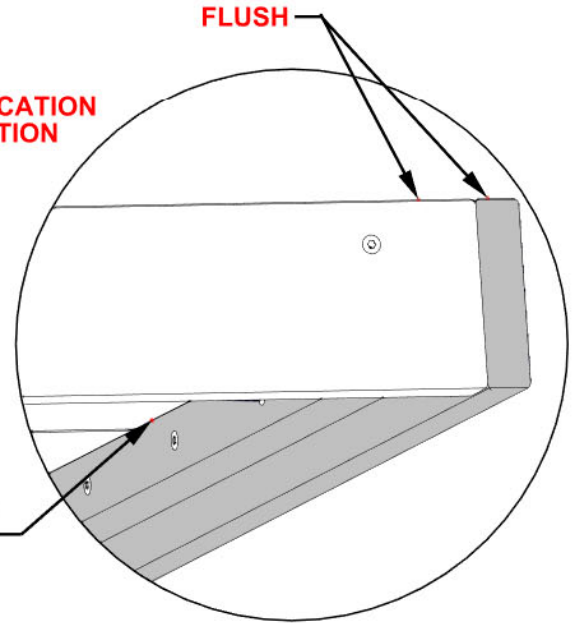

BUTT FASCIA ASSEMBLY TO BOTTOM SIDE OF ROOF BOARDS

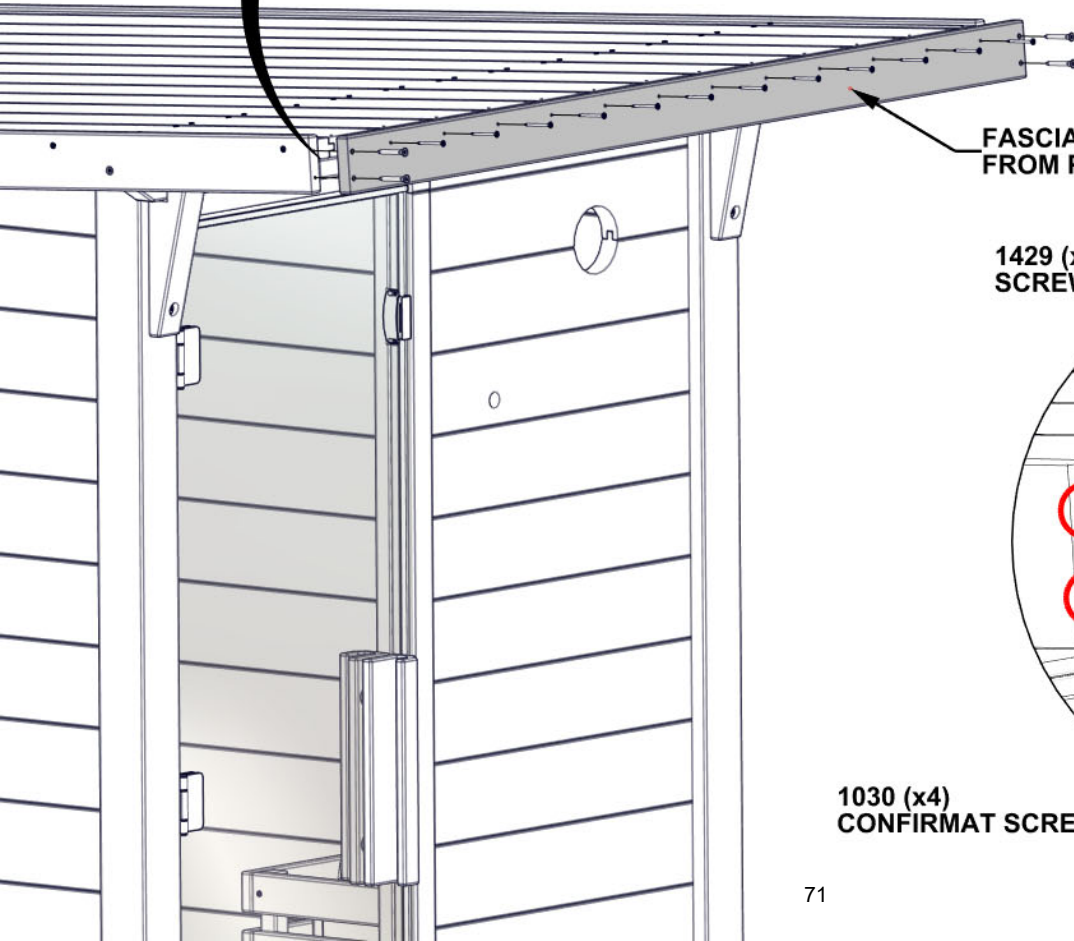

FASCIA ASSEMBLY FROM PREVIOUS STEP

1429 (x12)
SCREW - 2"

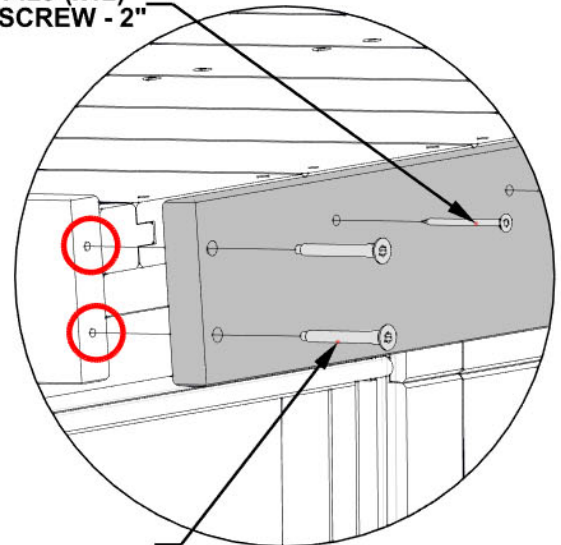

1030 (x4)
CONFIRMAT SCREW - 2"

STEP 48 - ROOF ASSEMBLY

QTY	PART NUMBER	DESCRIPTION
2	H100405	WASHER LOCK EXT BLK
2	H100487	LAG SCREW WH BLK
26	H101429	SCREW TFH 8X2 SS-BLK

- ONCE FASCIA ASSEMBLY IS LINED UP WITH THROUGH HOLES IN ROOF BOARDS FROM THE PREVIOUS STEP, ATTACH AS SHOWN.

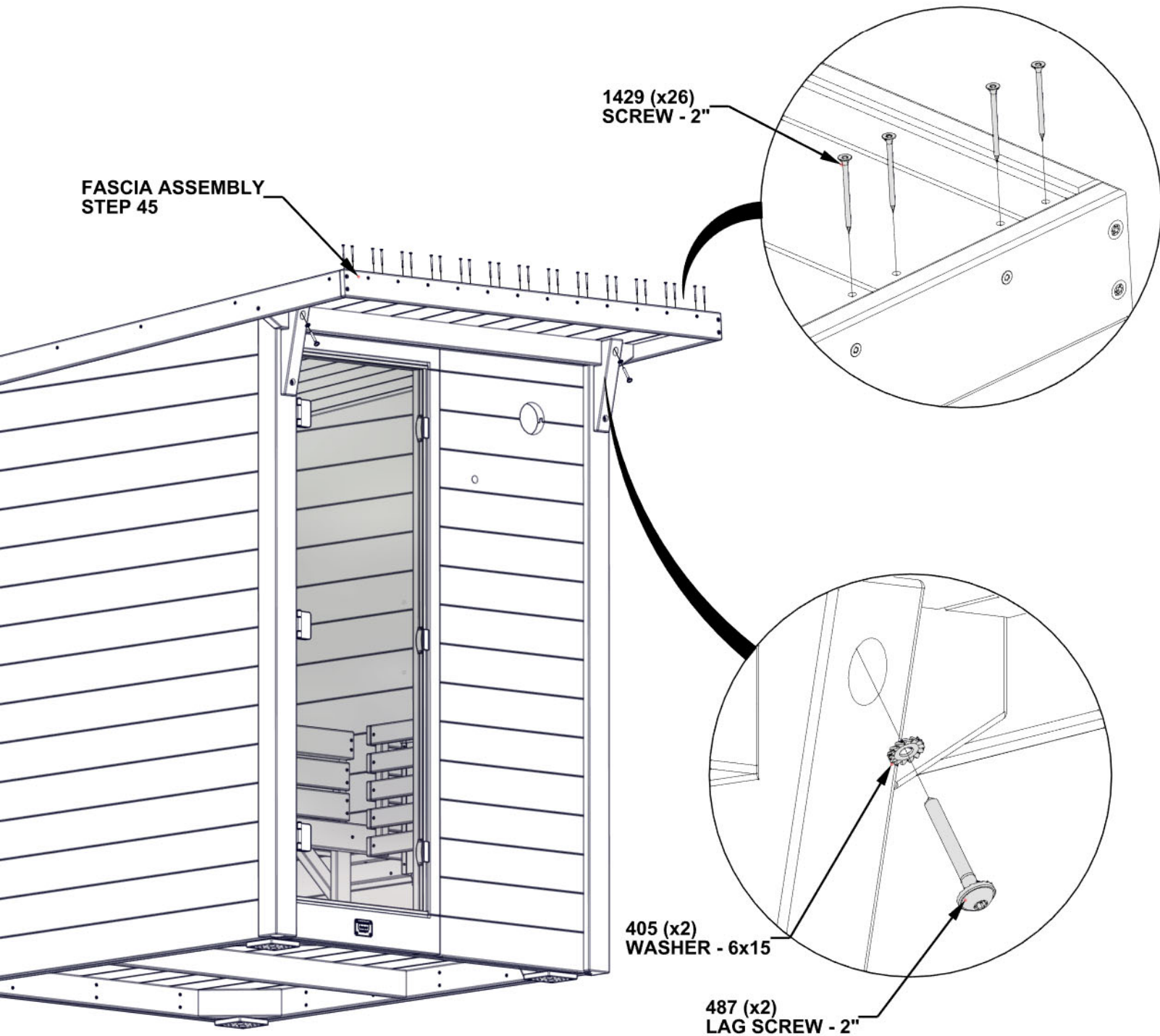

STEP 49 - ROOF ASSEMBLY

QTY	PART NUMBER	DESCRIPTION
12	H101429	SCREW TFH 8X2 SS-BLK



NG03 FASCIA - W4L22362
(x1) 13/16"x3 1/8"x60 3/8" (20x80x1534)

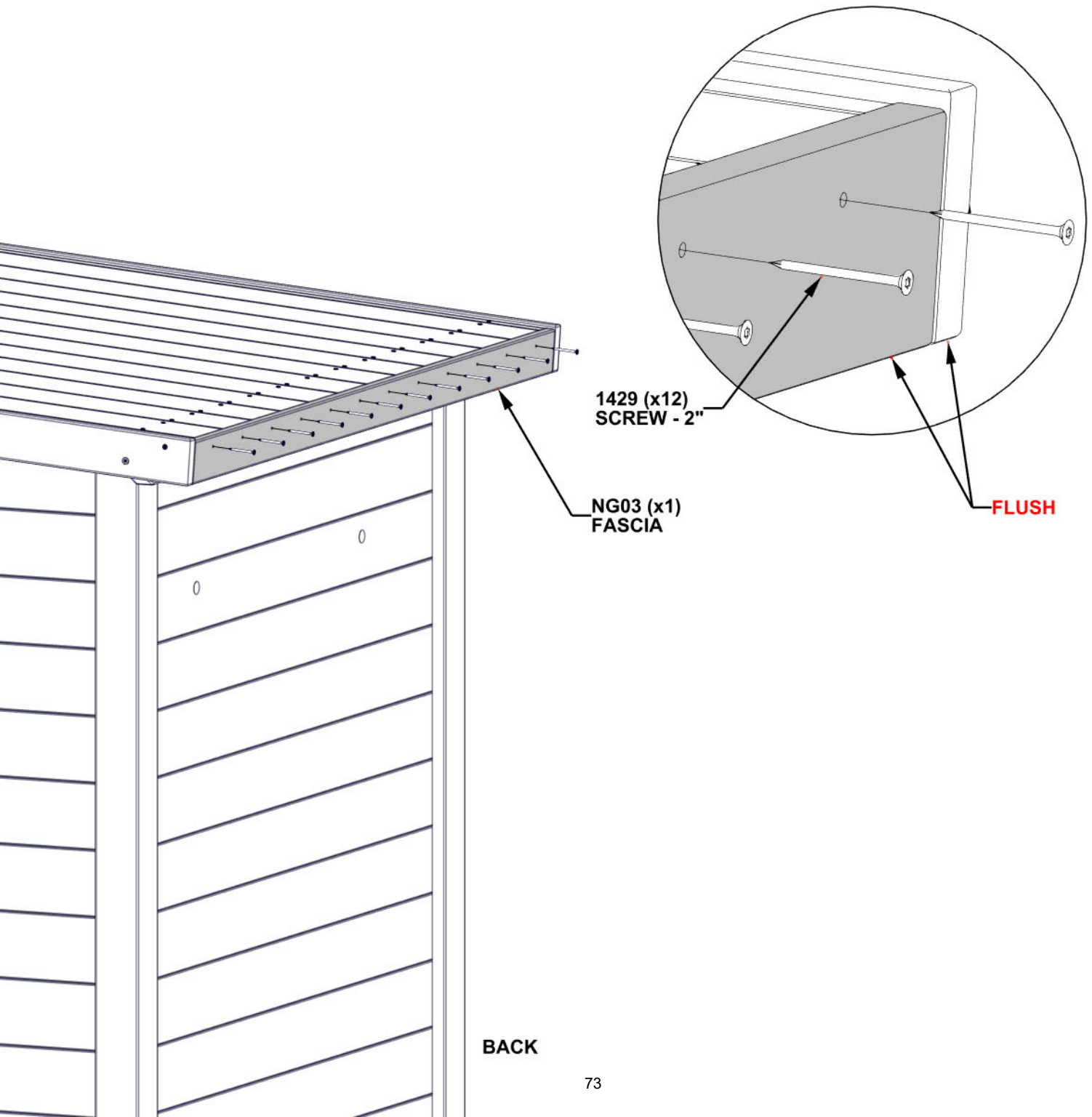

BACK

STEP 50 - ROOF ASSEMBLY

QTY	PART NUMBER	DESCRIPTION
12	H101429	SCREW TFH 8X2 SS-BLK

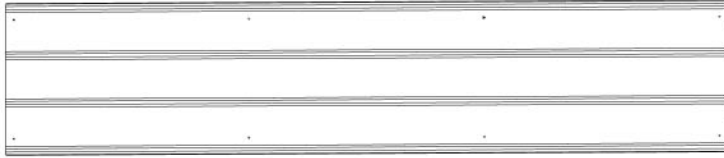

- **WARNING: USE GLOVES WHEN HANDLING STEEL SHEETING.**
- **IMPORTANT: REMOVE BLUE FILM BEFORE INSTALLATION.**
- STARTING ON LEFT HAND SIDE, FLUSH SHEETING AGAINST ROOF TRIM AND FASCIA AS SHOWN.
- CONTINUE FROM LEFT TO RIGHT BY LAYING SHEETING DOWN OVERLAPPING EACH SHEET BY ONE RIB.

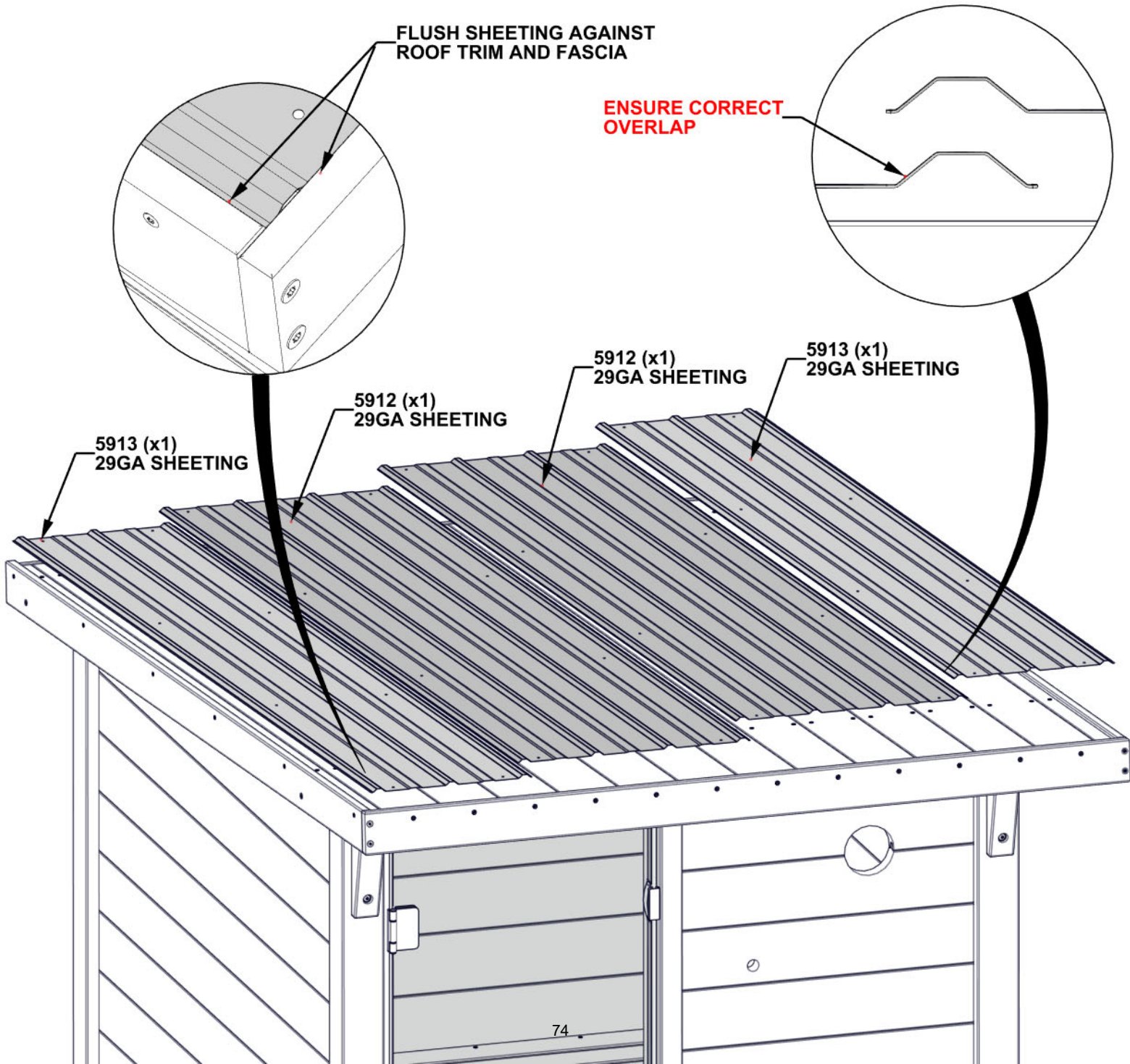

STEP 51 - ROOF ASSEMBLY

QTY	PART NUMBER	DESCRIPTION
32	H101117	SCREW WOODGRIP

- WARNING: USE GLOVES WHEN HANDLING STEEL SHEETING.
- IMPORTANT: REMOVE BLUE FILM BEFORE INSTALLATION.
- THE BACK OF THE SAUNA WILL HAVE A SMALL OVERHANG AS SHOWN.

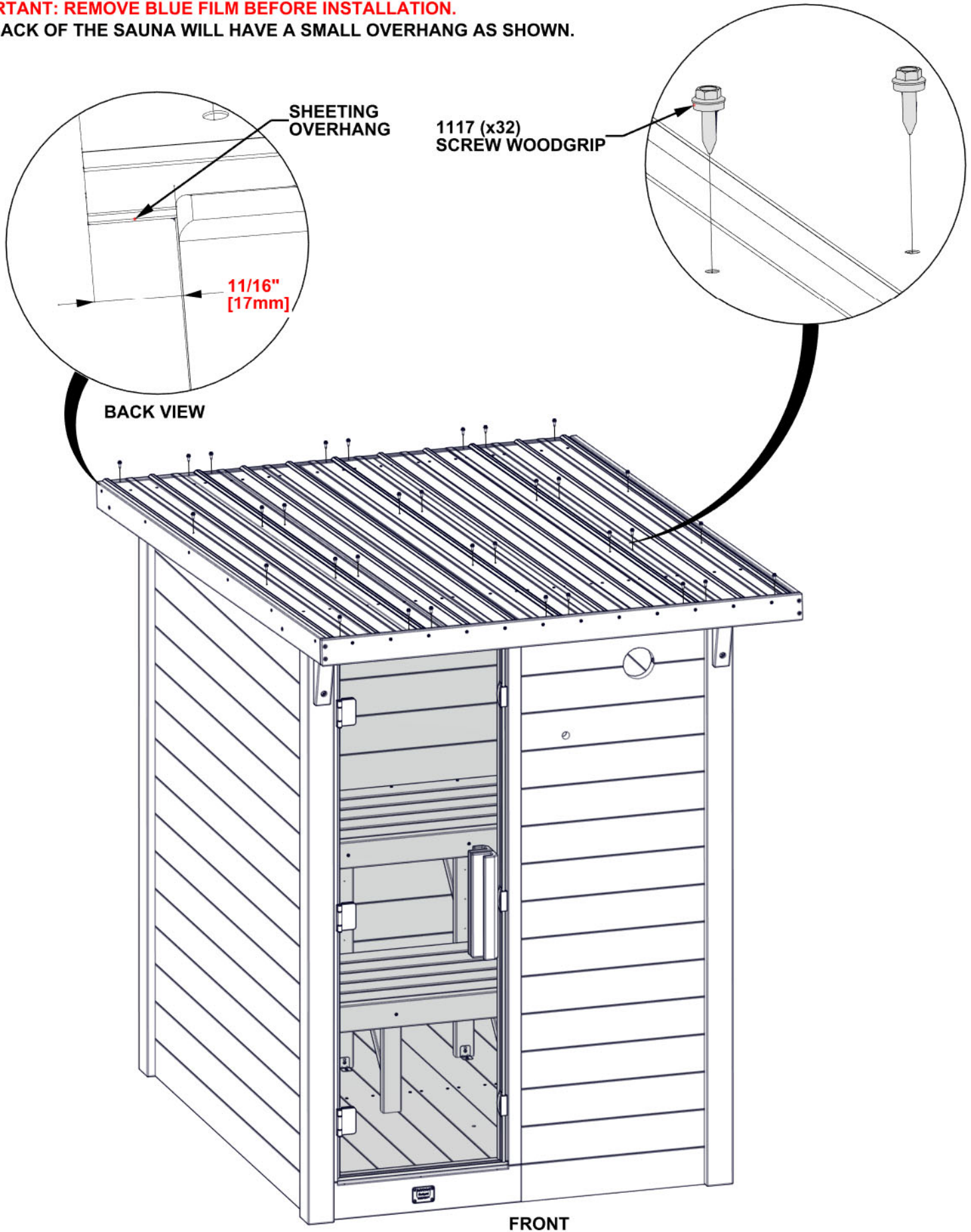

STEP 52 - ROOF ASSEMBLY

QTY	PART NUMBER	DESCRIPTION
8	H101116	SCREW SELF TAPPING 1/4x1 BLK

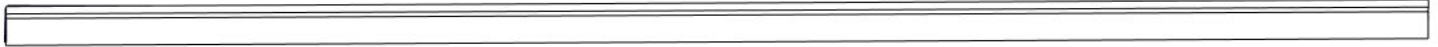

A4M05914 EDGE TRIM
(x2)

- **WARNING: USE GLOVES WHEN HANDLING STEEL SHEETING.**
- **IMPORTANT: REMOVE BLUE FILM BEFORE INSTALLATION.**
- FLUSH EDGE TRIM WITH SHEETING INSTALLED IN PREVIOUS STEP.
- ATTACH AS SHOWN. AT THE APPROXIMATE LOCATIONS ON BOTH SIDES OF SAUNA.

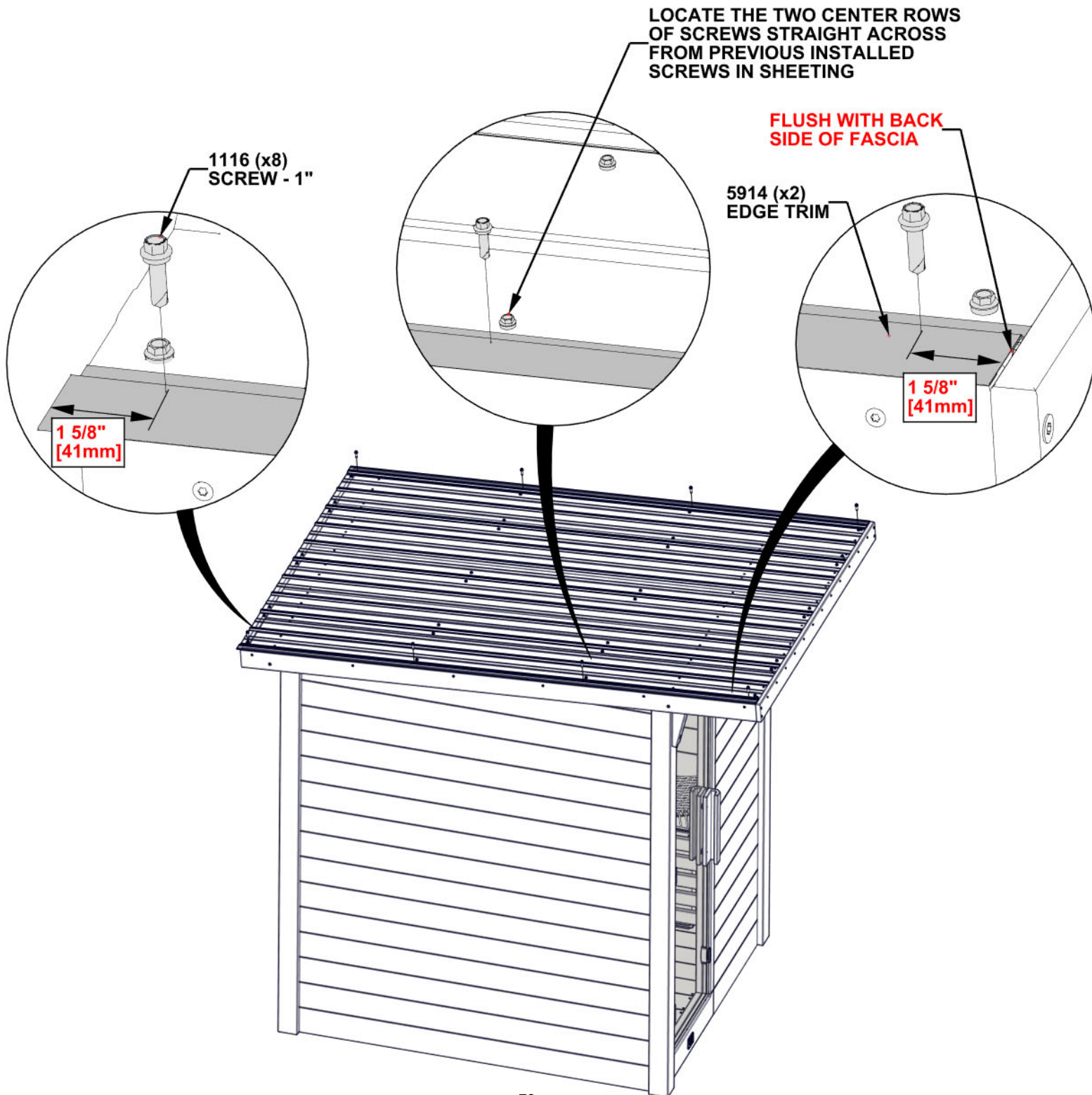

STEP 53 - ROOF ASSEMBLY

QTY	PART NUMBER	DESCRIPTION
6	H101117	SCREW WOODGRIP 10-16x3/4" BLK



5915 EDGE TRIM - A4M05915
(x1) 1/32"x2 9/16"x62" (0.50x66x1575)

- **WARNING: USE GLOVES WHEN HANDLING STEEL SHEETING.**
- **IMPORTANT: REMOVE BLUE FILM BEFORE INSTALLATION.**
- POSITION EDGE TRIM AS SHOWN. USE DIMENSION TO LOCATE AND ATTACH SCREW.
- SKIP NEXT RIB AND FASTEN AT EVERY OTHER RIB LOCATION AS SHOWN IN DETAIL.

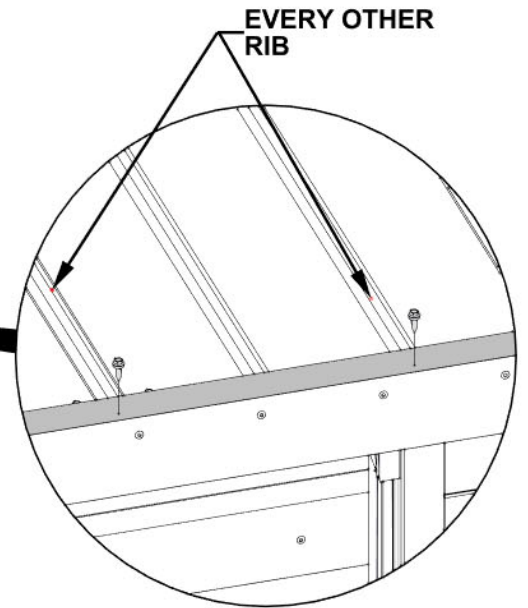
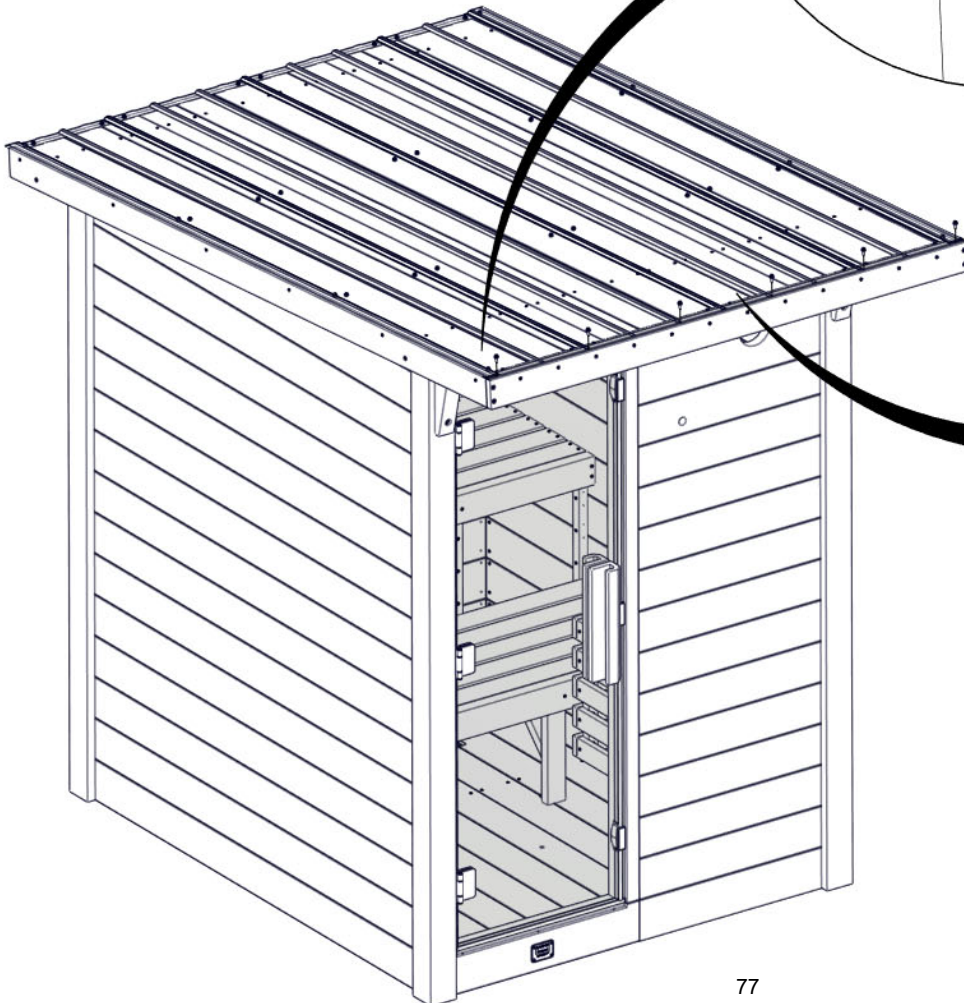
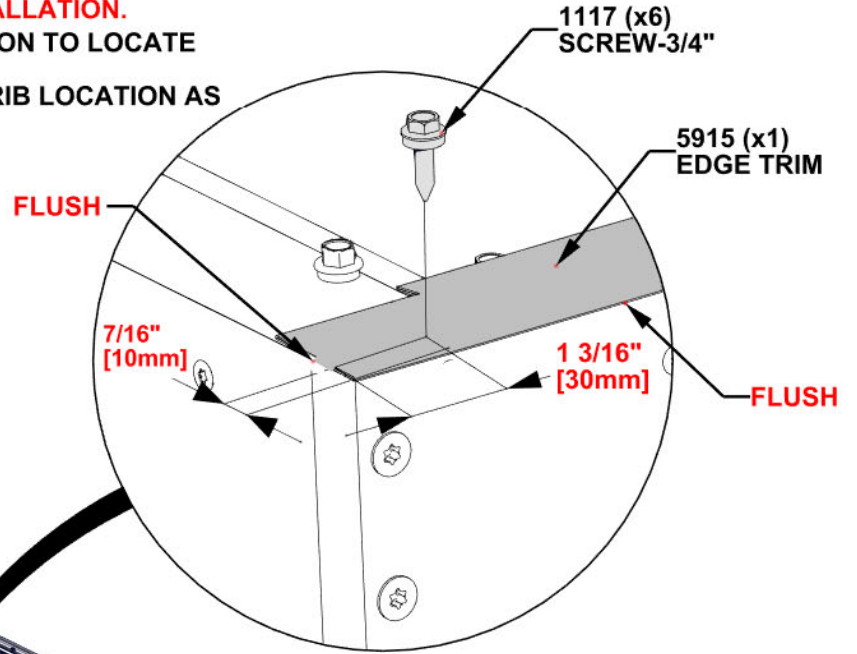

STEP 54 - CONTROL PANEL

QTY	PART NUMBER	DESCRIPTION
2	H100627	SCREW PFH 6x3/4 BLK



A4M05590-03 CONTROL PANEL MOUNTING BRACKET (x1)

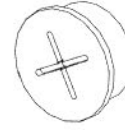

25mm) 25mm SILICONE GROMMET (x1)

- CENTER MOUNTING BRACKET SLIGHTLY OVER CUTOUT IN WALL PANEL AND ATTACH AS SHOWN.
- INSERT GROMMET.

CONTROL PANEL MOUNTING BRACKET (x1)

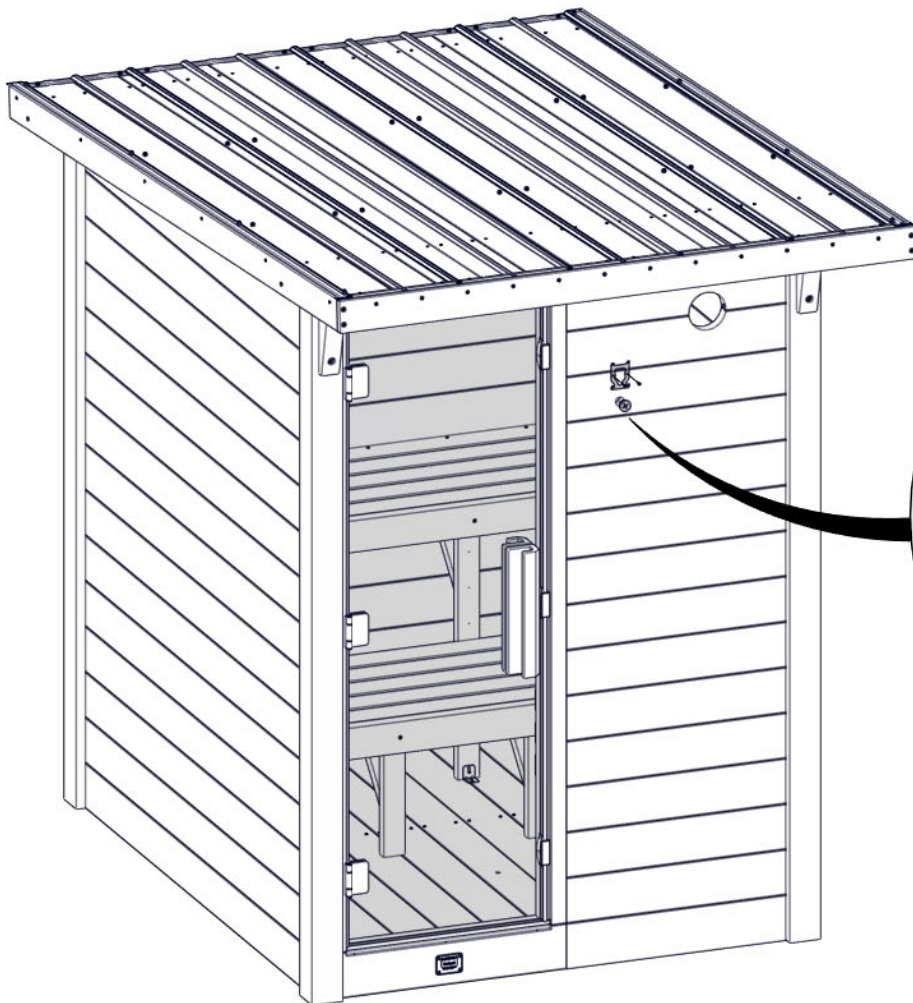
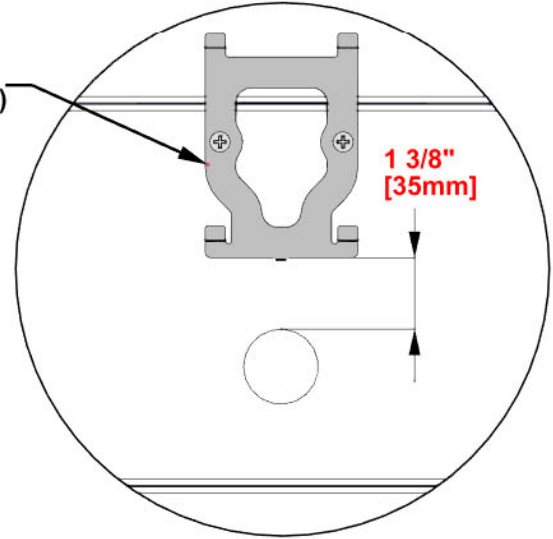

627 (x2) SCREW - 3/4"

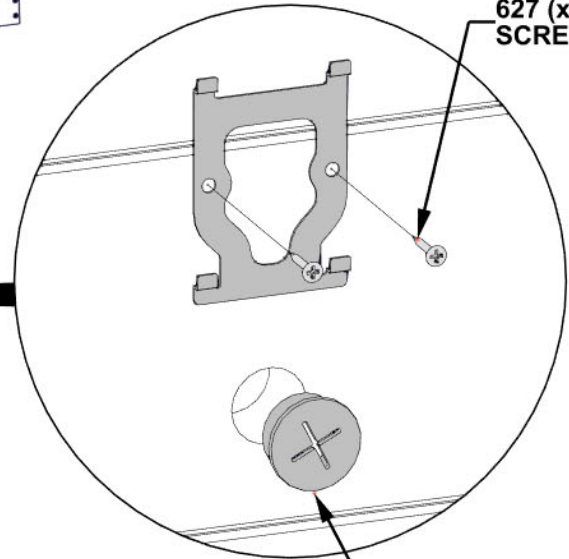

1467 (x1) GROMMET - 25mm

STEP 55 - CONTROL PANEL

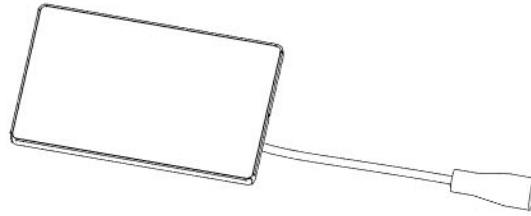

A4M05590-02 CONTROL PANEL
(x1)

HANG CONTROL PANEL ON
HOOKS ON CONTROL PANEL
BRACKET AND SNAP INTO
PLACE

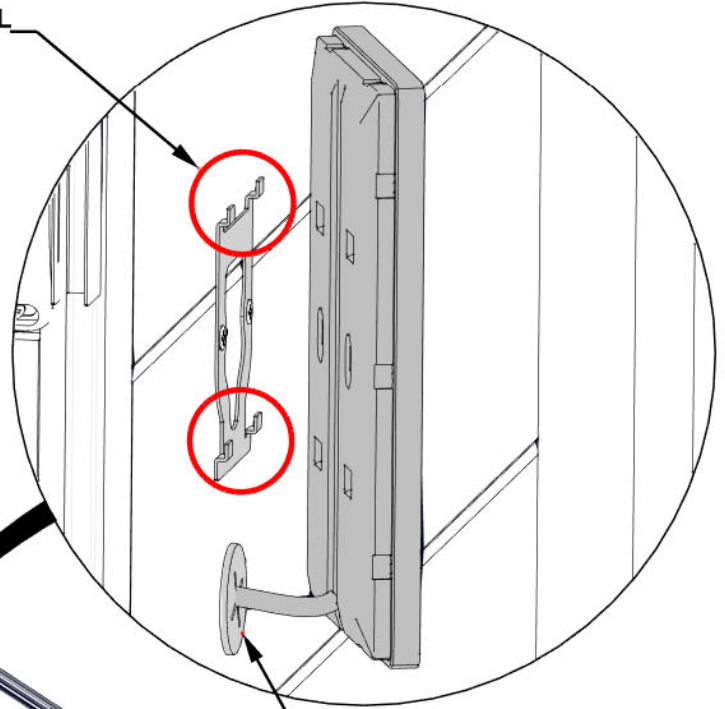

RUN CORD THROUGH
GROMMET

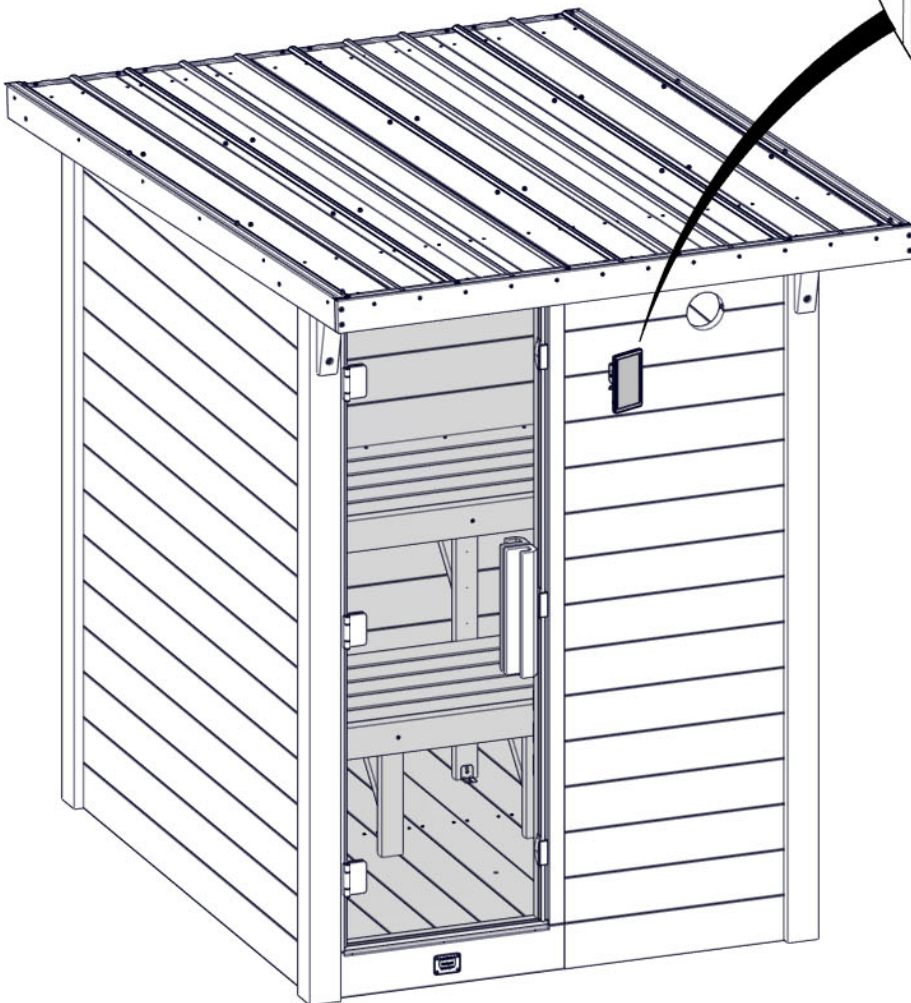

STEP 56 - CONTROL PANEL

QTY	PART NUMBER	DESCRIPTION
4	H101428	SCREW TFH 8X1 3/4 SS-BLK

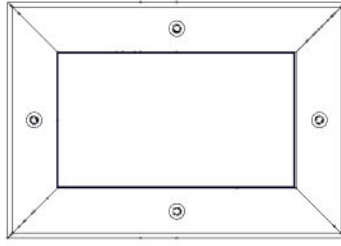

TF01 TRIM FRAME - W2A04797
(x1) 7/8"x5 9/16"x8 1/16" (22x142x204)

- PLACE TRIM FRAME ON CONTROL PANEL ENSURING IT SEATS AROUND THE CONTROL PANEL AND ATTACH AS SHOWN.

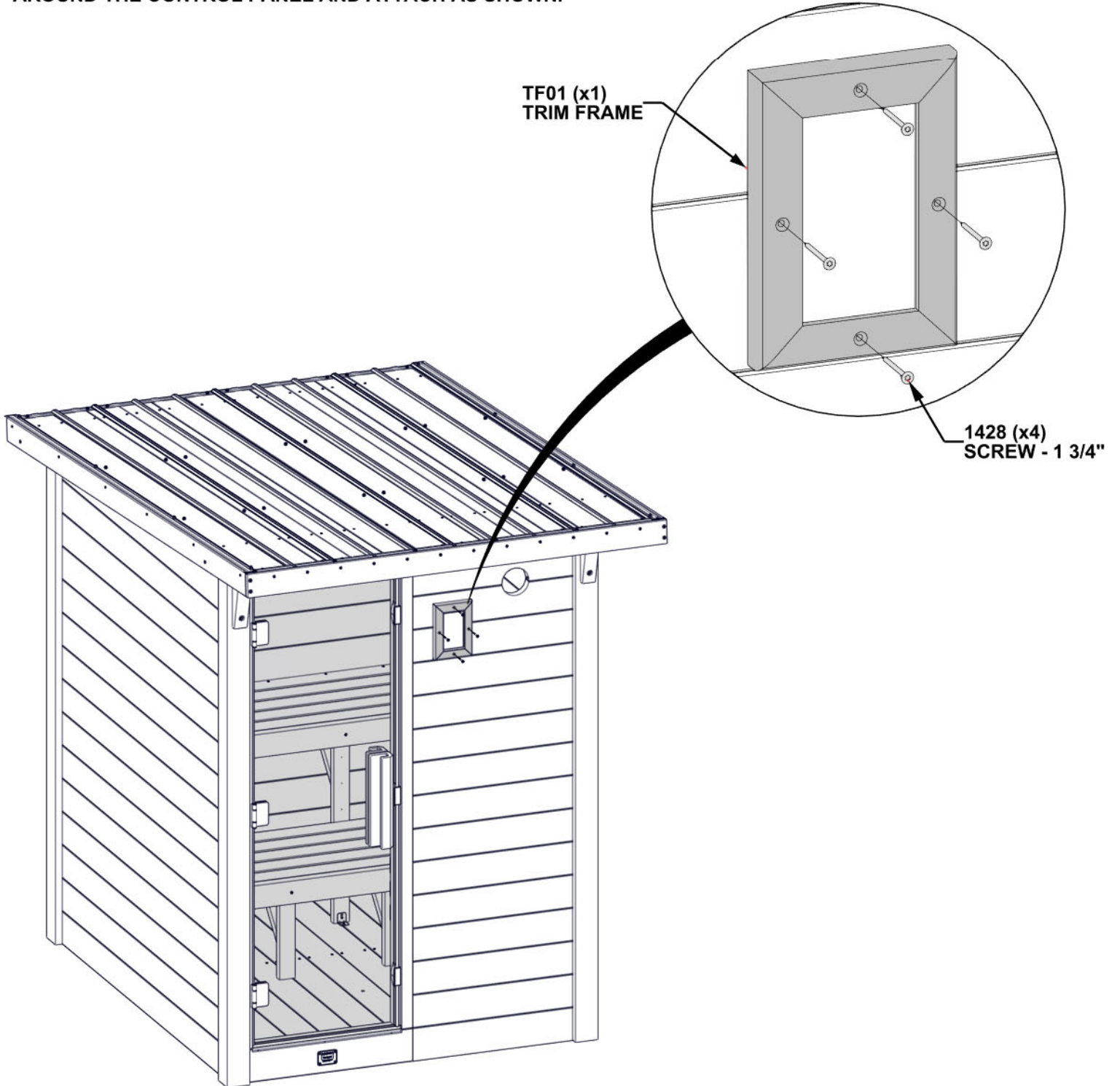

STEP 57 - CONTROL PANEL

QTY	PART NUMBER	DESCRIPTION
4	H101429	SCREW TFH 8X2 SS-BLK



A4M05590-10 WIRING HARNESS (x1)



OG12 WIREWAY BOARD - W4L22389 (x1) 1 3/16"x3 3/8"x19 3/4" (30x86x501)

- CONNECT WIRING HARNESS TO CORD FROM STEP 56
- HOLD CONNECTED CORDS UP TO THE TOP OF THE SAUNA, CENTER WIREWAY BOARD OVER HOLE IN FRONT WALL, AND ATTACH BOARD AS SHOWN.
- TAKE CAUTION WHEN ATTACHING SCREWS TO PREVENT PINCHING OR PENETRATING CORDS.

WIRING HARNESS (x1)

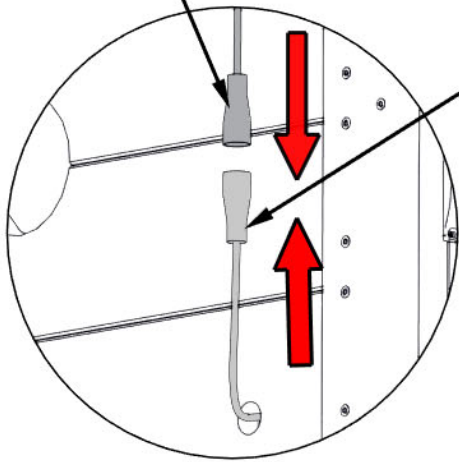

CORD FROM STEP 56

ENSURE NOTCH IS ORIENTED TO TOP AND WIREWAY BOARD IS POSITIONED AGAINST THE CEILING

OG12 (x1) WIREWAY BOARD

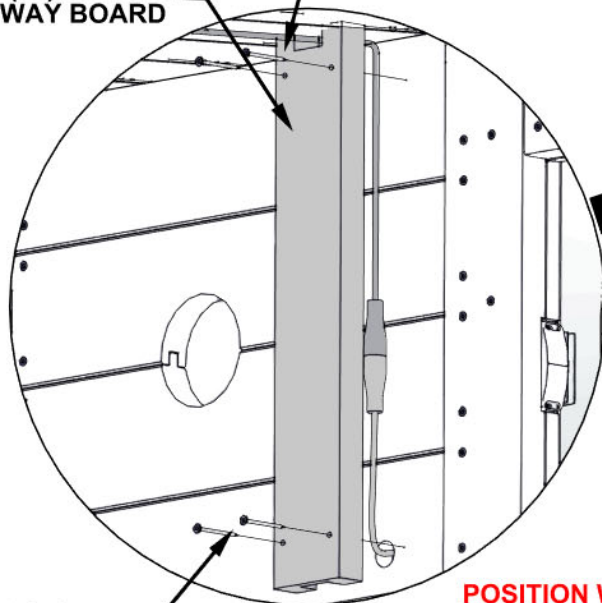

1429 (x4) SCREW - 2"

POSITION WIREWAY BOARD 2 7/16" [62mm] FROM EDGE OF DOOR FRAME

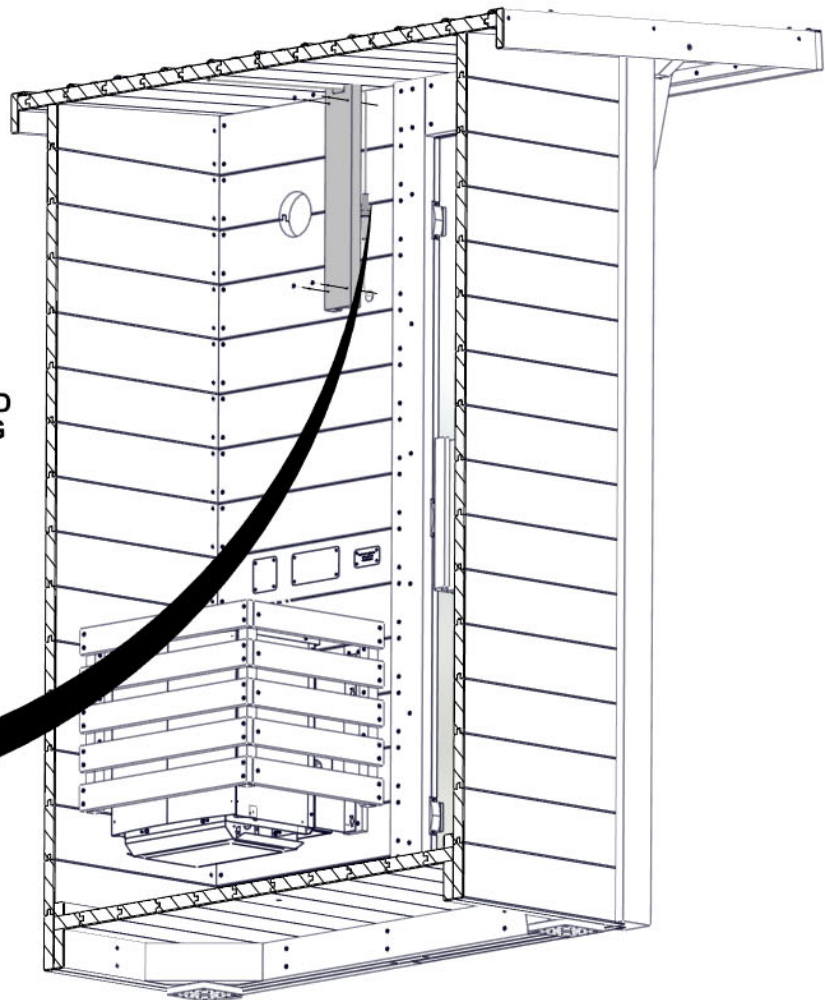

BACK OF SAUNA HIDDEN FOR DETAIL

STEP 58 - CONTROL PANEL

QTY	PART NUMBER	DESCRIPTION
4	H101429	SCREW TFH 8X2 SS-BLK

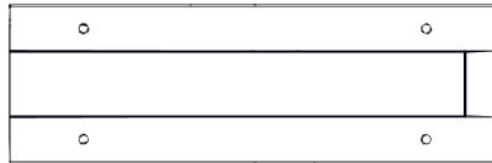

OG11 WIREWAY BOARD - W4L22388
(x1) 1 3/16"x3 3/8"x10 1/2" (30x86x266)

- RUN CORD FROM PREVIOUS STEP STRAIGHT BACK AND USE DIMENSION SHOWN TO LOCATE AND ATTACH OG11.
- RUN EXCESS CORD THROUGH HOLE IN BACK WALL AS SHOWN.
- TAKE CAUTION WHEN ATTACHING SCREWS TO PREVENT PINCHING OR PENETRATING CORDS.

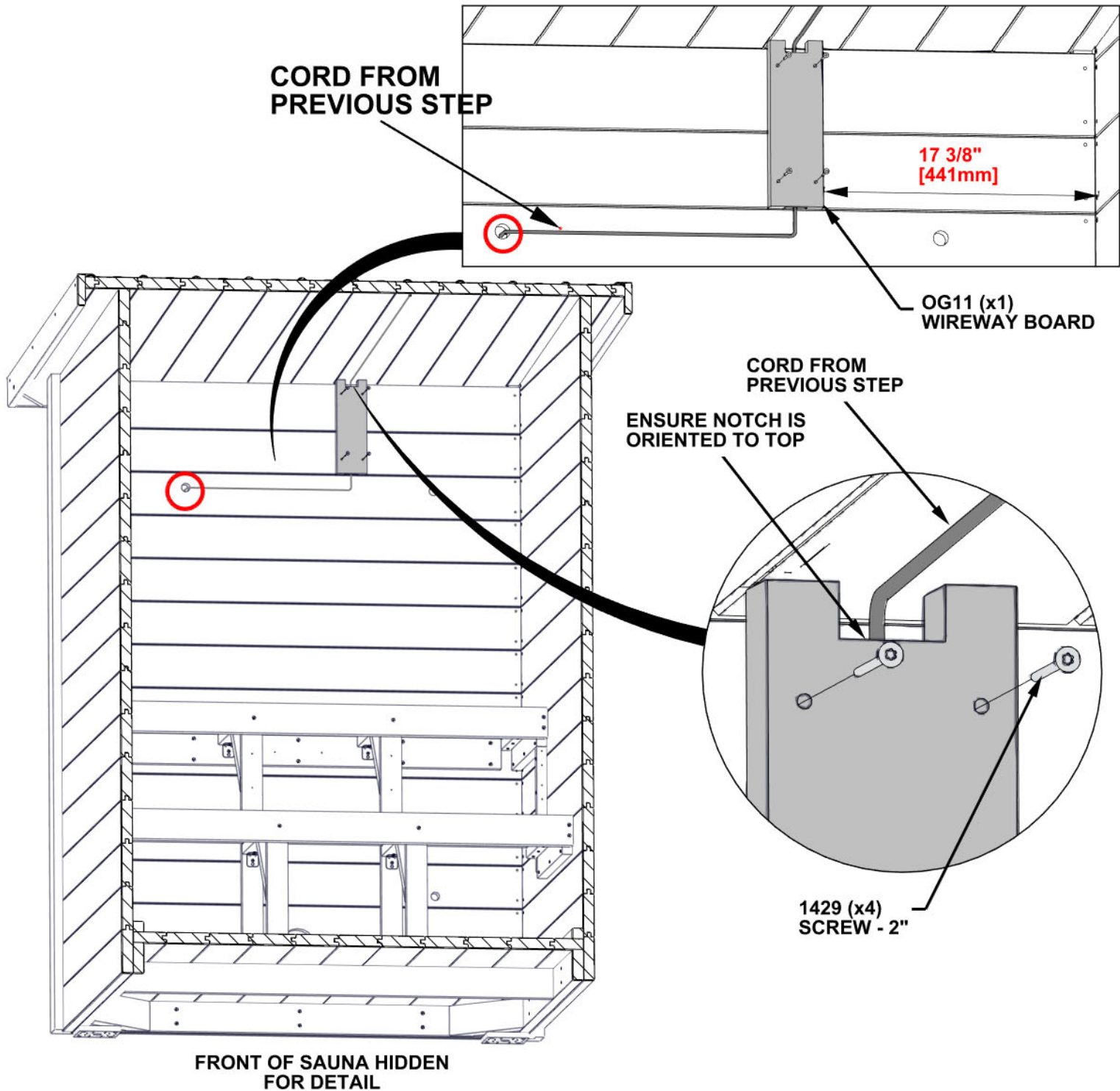

STEP 59 - LED LIGHT

QTY	PART NUMBER	DESCRIPTION
2	H101437	SCREW TWH 8x5/8 SS-BLK



OG13 LIGHT MOUNT - W4L22391
(x1) 30x3 3/8"x35 7/16" (30x86x900)

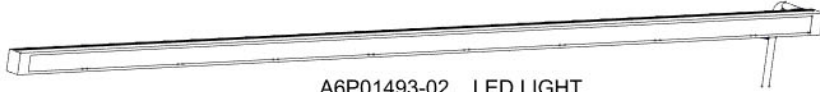

A6P01493-02 LED LIGHT
(x1)

- ATTACH LIGHT CLIPS IN APPROXIMATE LOCATIONS SHOWN.
- USE DIMENSIONS TO LOCATE CLIPS.
- SNAP LED LIGHT INTO CLIPS.

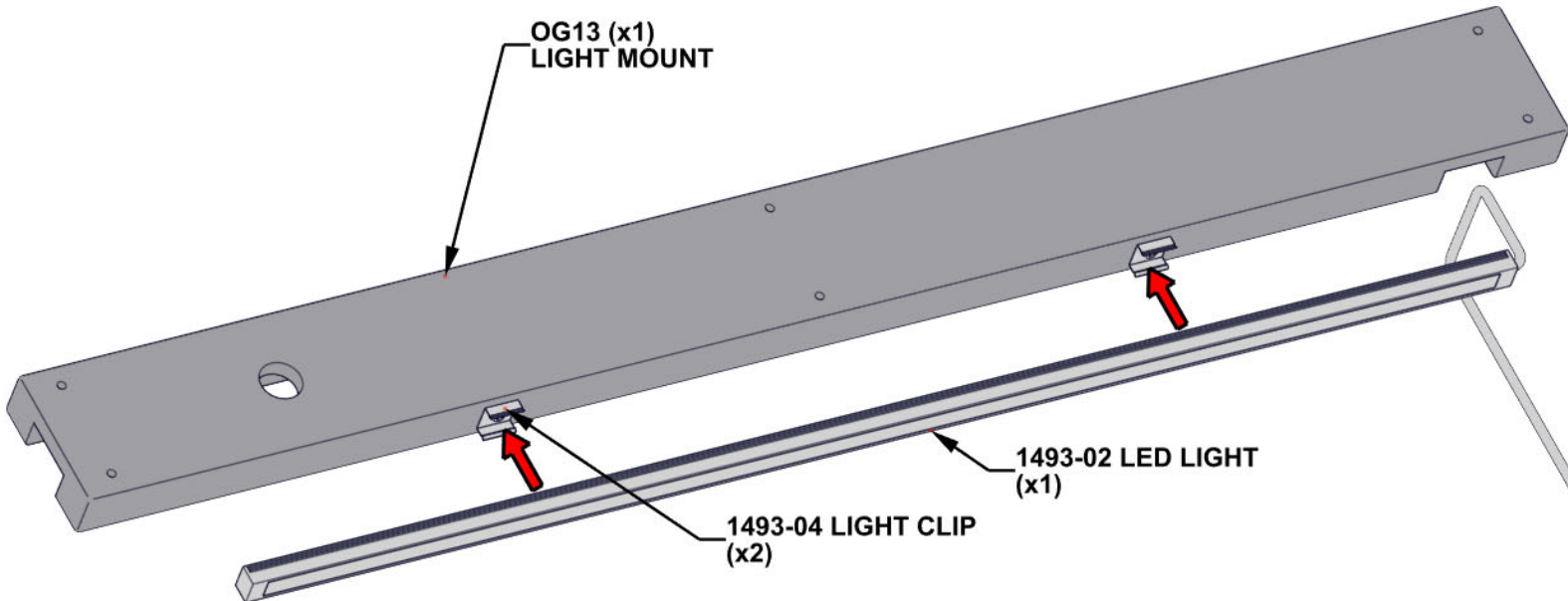
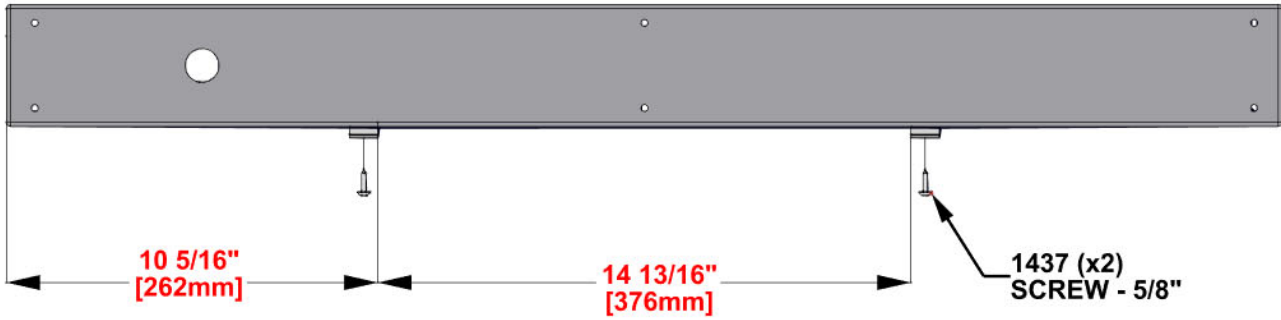

STEP 60 - LED LIGHT

QTY	PART NUMBER	DESCRIPTION
6	H101429	SCREW TFH 8X2 SS-BLK

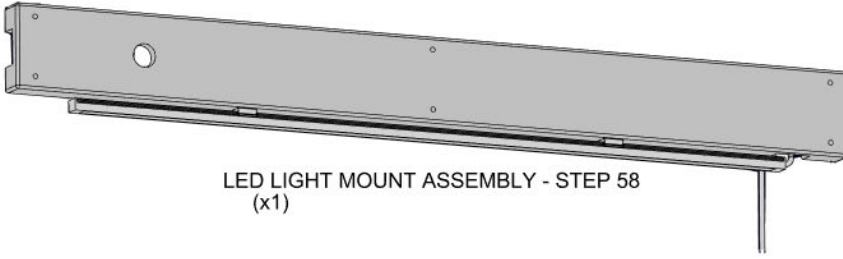

- ALIGN HOLE IN LED LIGHT MOUNT ASSEMBLY FROM STEP 58 TO THE HOLE PROVIDED IN THE WALL.
- ENSURE THAT THE NOTCH IN THE LED LIGHT MOUNT ASSEMBLY ALIGNS WITH THE WIREWAY INSTALLED IN STEP 57.
- POSITION LED LIGHT MOUNT ASSEMBLY SO THAT IT IS FLUSH WITH THE BOTTOM OF THE WIREWAY FROM STEP 57.
- CHECK THAT LED LIGHT MOUNT ASSEMBLY IS LEVEL AND ATTACH AS SHOWN.
- TAKE CAUTION WHEN ATTACHING SCREWS TO PREVENT PINCHING OR PENETRATING CORDS.

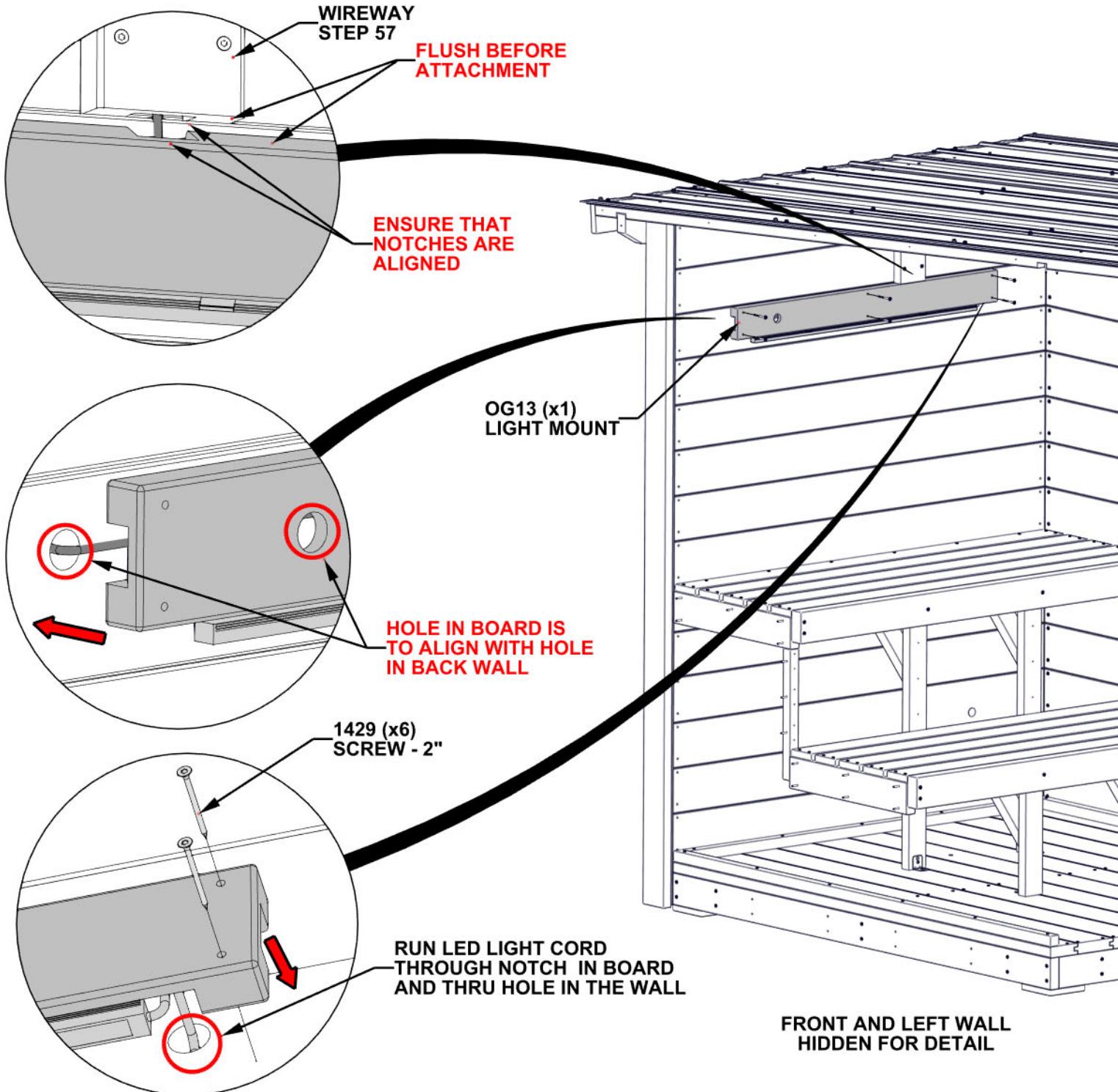

STEP 61 - CONTROL PANEL

QTY	PART NUMBER	DESCRIPTION
10	H101429	SCREW TFH 8X2 SS-BLK

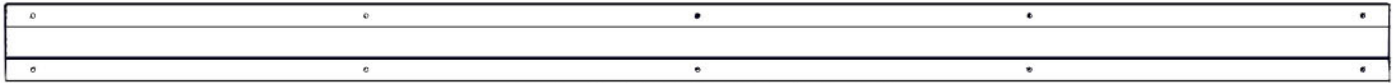

OG10 WIREWAY BOARD - W4L22387
(x1) 1 3/16"x3 3/8"x60 3/4" (30x86x1543)

- ENSURE CORD RESTS IN GROOVE IN THE TOP OF THE WIREWAY BOARD AS BOARD IS PUT INTO POSITION.
- ALIGN WITH PREVIOUSLY INSTALLED WIREWAY BOARDS ON THE FRONT AND BACK WALLS.
- ATTACH AS SHOWN.
- TAKE CAUTION WHEN ATTACHING SCREWS TO PREVENT PINCHING OR PENETRATING CORDS.

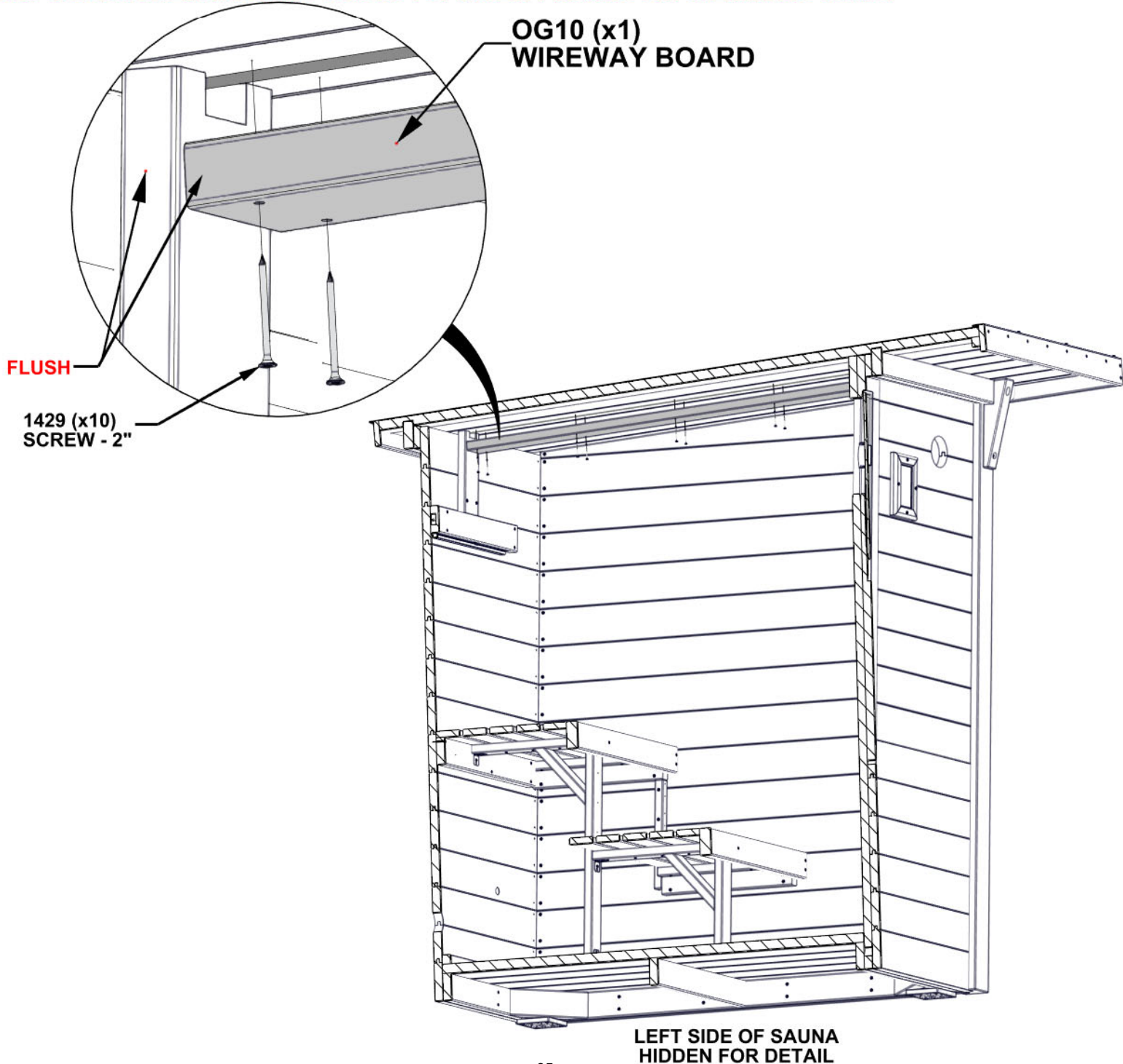

STEP 62 - TEMPERATURE SENSOR

QTY	PART NUMBER	DESCRIPTION
2	H101440	SCREW TWH 8x1 SS-BLK

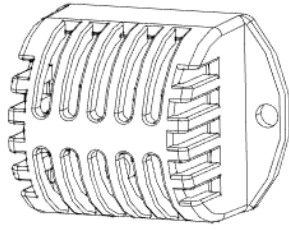

A4M05590-08 TEMPERATURE SENSOR (x1)

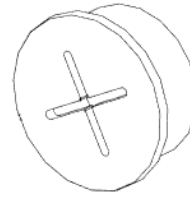

A6P01467 25mm SILICONE GROMMET (x1)

- RUN CORD FOR TEMPERATUR SENSOR THROUGH HOLE, AND CAREFULLY LET HANG UNTIL IT IS ATTACHED LATER.
- SLIDE GROMMET OVER CORDS AND INSERT INTO THE HOLE CUTOUT IN BACK WALL.

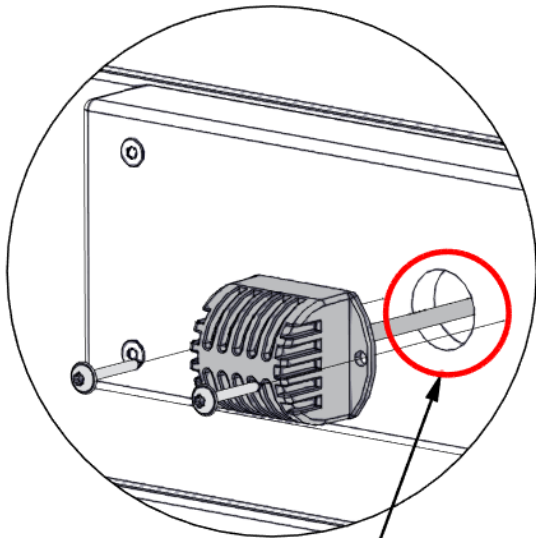

RUN CORD THROUGH HOLE AND OUT OF THE BACK OF THE SAUNA

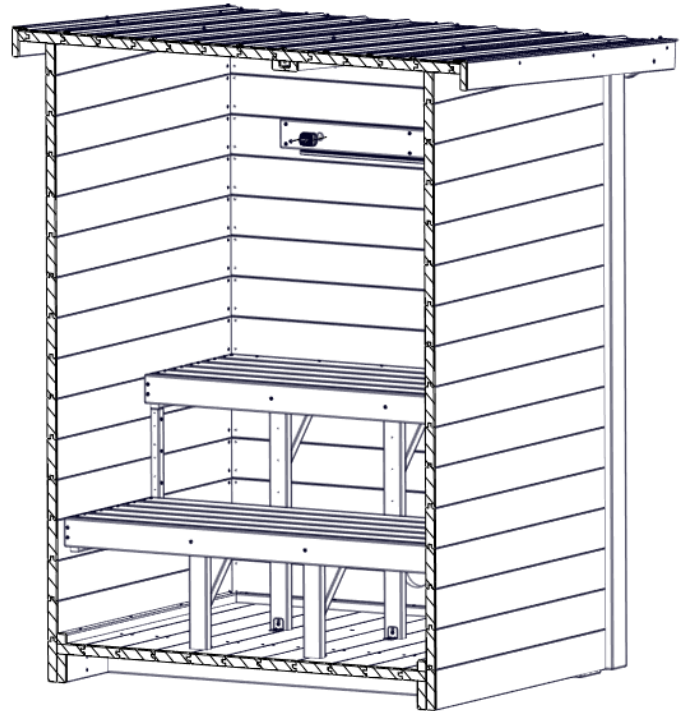

FRONT OF SAUNA HIDDEN FOR DETAIL

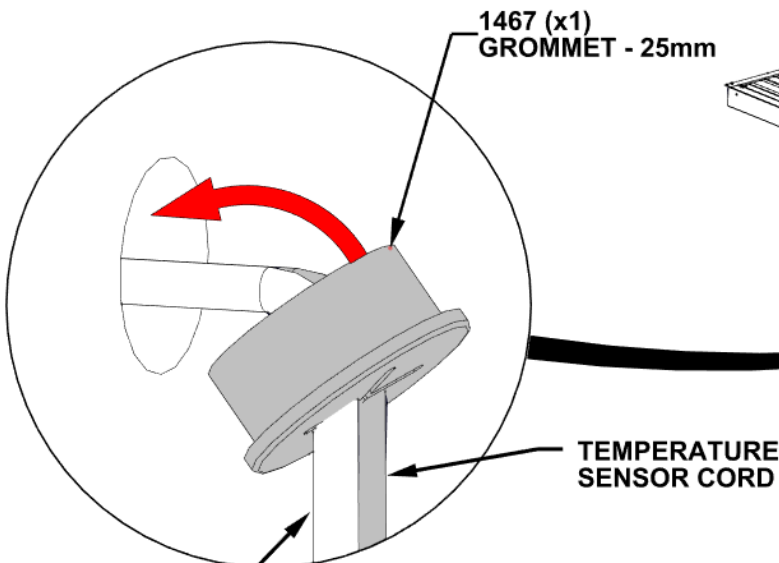

1467 (x1) GROMMET - 25mm

TEMPERATURE SENSOR CORD

WIRING HARNESS CORD

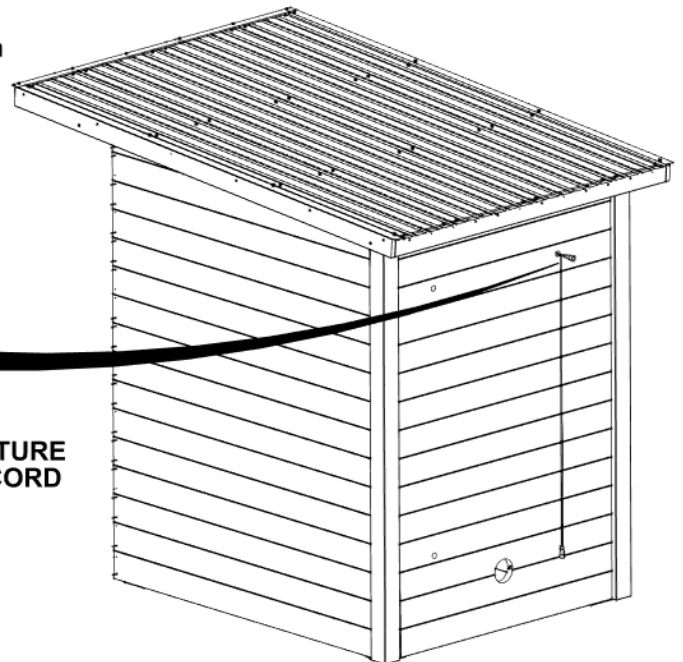

STEP 63 - TEMPERATURE SENSOR

QTY	PART NUMBER	DESCRIPTION
10	H101429	SCREW TFH 8X2 SS-BLK



OG14 WIREWAY BOARD - W4L22393
(x1) 1 3/16"x3 3/8"x53 9/16" (30x86x1360)

- ENSURE CORDS ARE POSITIONED IN GROOVE OF WIREWAY BOARD BEFORE CENTERING OVER HOLE IN THE BACK WALL.
- ATTACH WIREWAY BOARD AS SHOWN.

- TAKE CAUTION WHEN ATTACHING SCREWS TO PREVENT PINCHING OR PENETRATING CORDS.

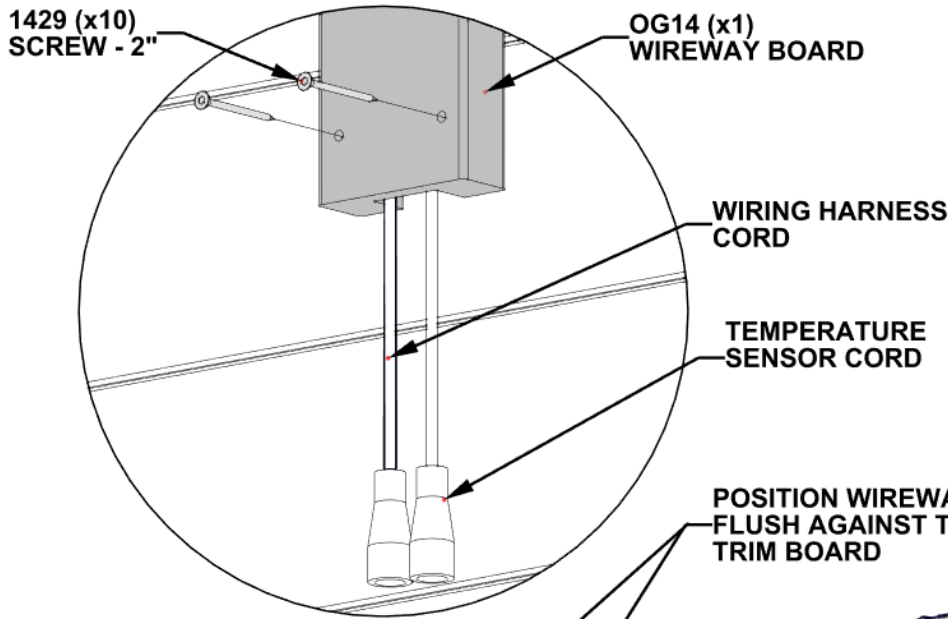

POSITION WIREWAY BOARD
FLUSH AGAINST THE
TRIM BOARD

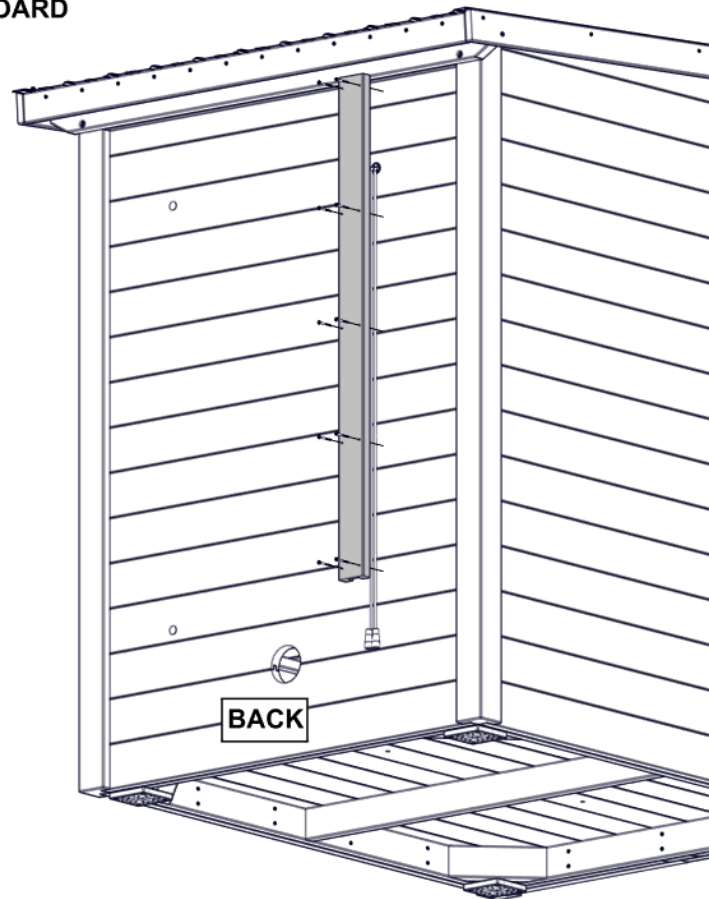
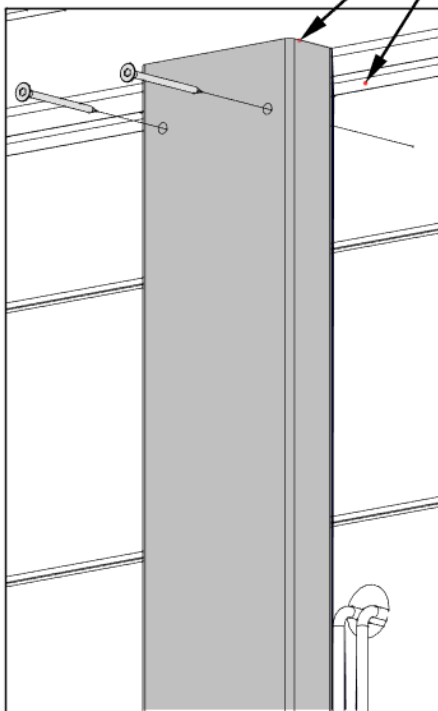

STEP 64 - LED LIGHTS



A6P01493-02 LED LIGHT
(x1)

- BEFORE CLIPPING LIGHT INTO PLACE, RUN CORDS THROUGH HOLE IN BACK WALL.
- SNAP LED LIGHT INTO LIGHT CLIPS.

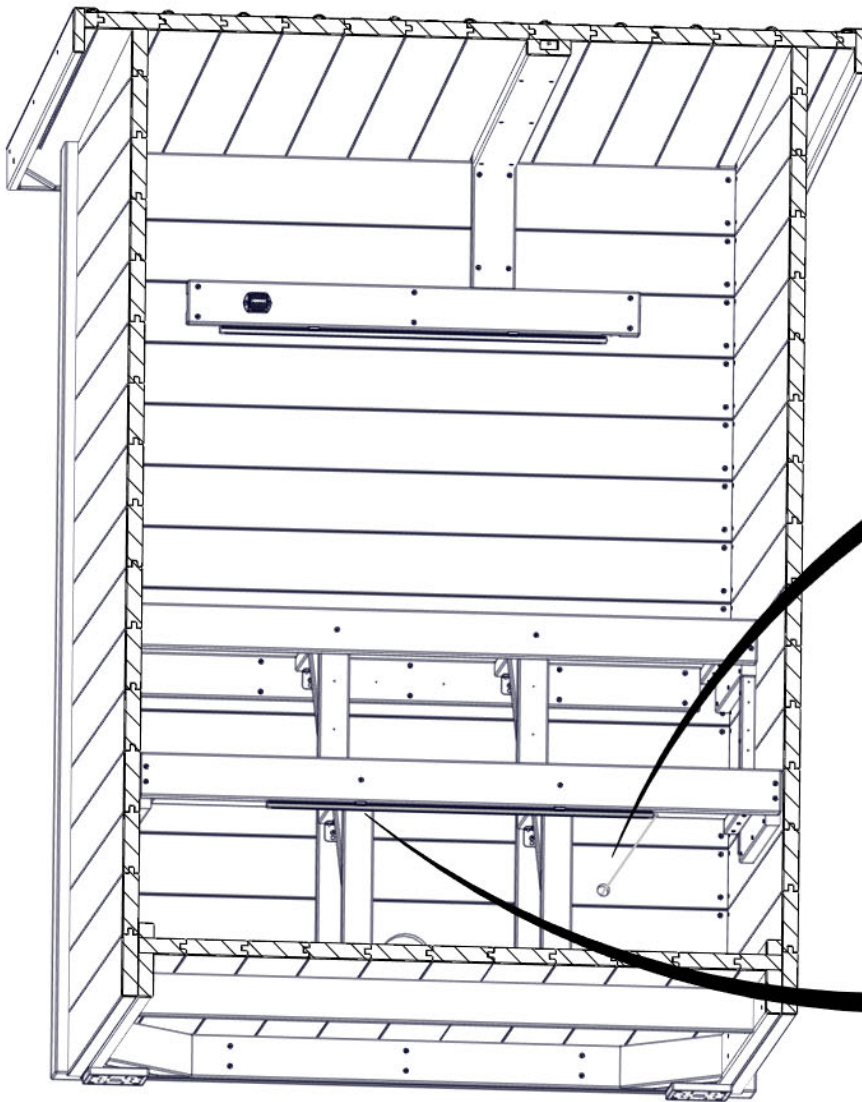

FRONT OF SAUNA HIDDEN
FOR DETAIL

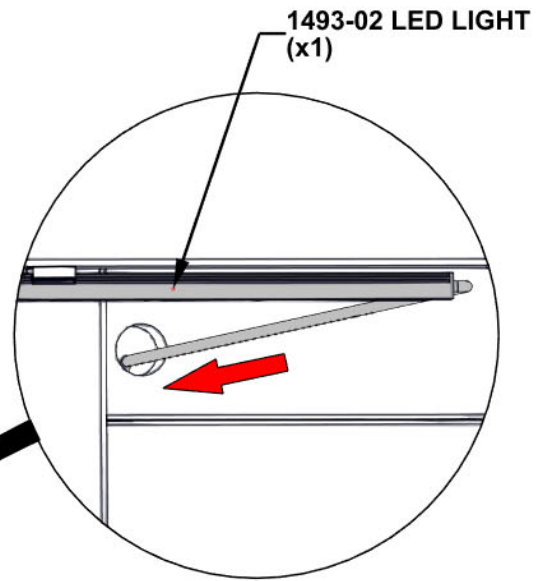

1493-02 LED LIGHT
(x1)

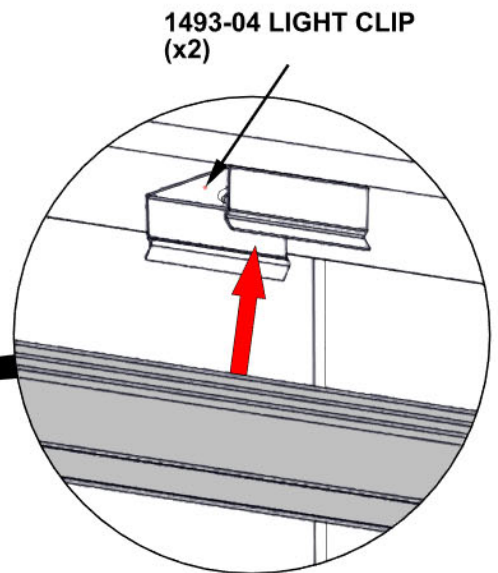

1493-04 LIGHT CLIP
(x2)

STEP 65 - BENCH ASSEMBLY

QTY	PART NUMBER	DESCRIPTION
18	H101428	SCREW TFH 8X1 3/4 SS-BLK



NG04 SLAT - W4L22385
(x3) 13/16"x3 3/8"x50 1/4" (20x86x1276)

- ALIGN THROUGH HOLES IN SLATS WITH PILOT HOLES IN CLEATS AND UPRIGHTS.

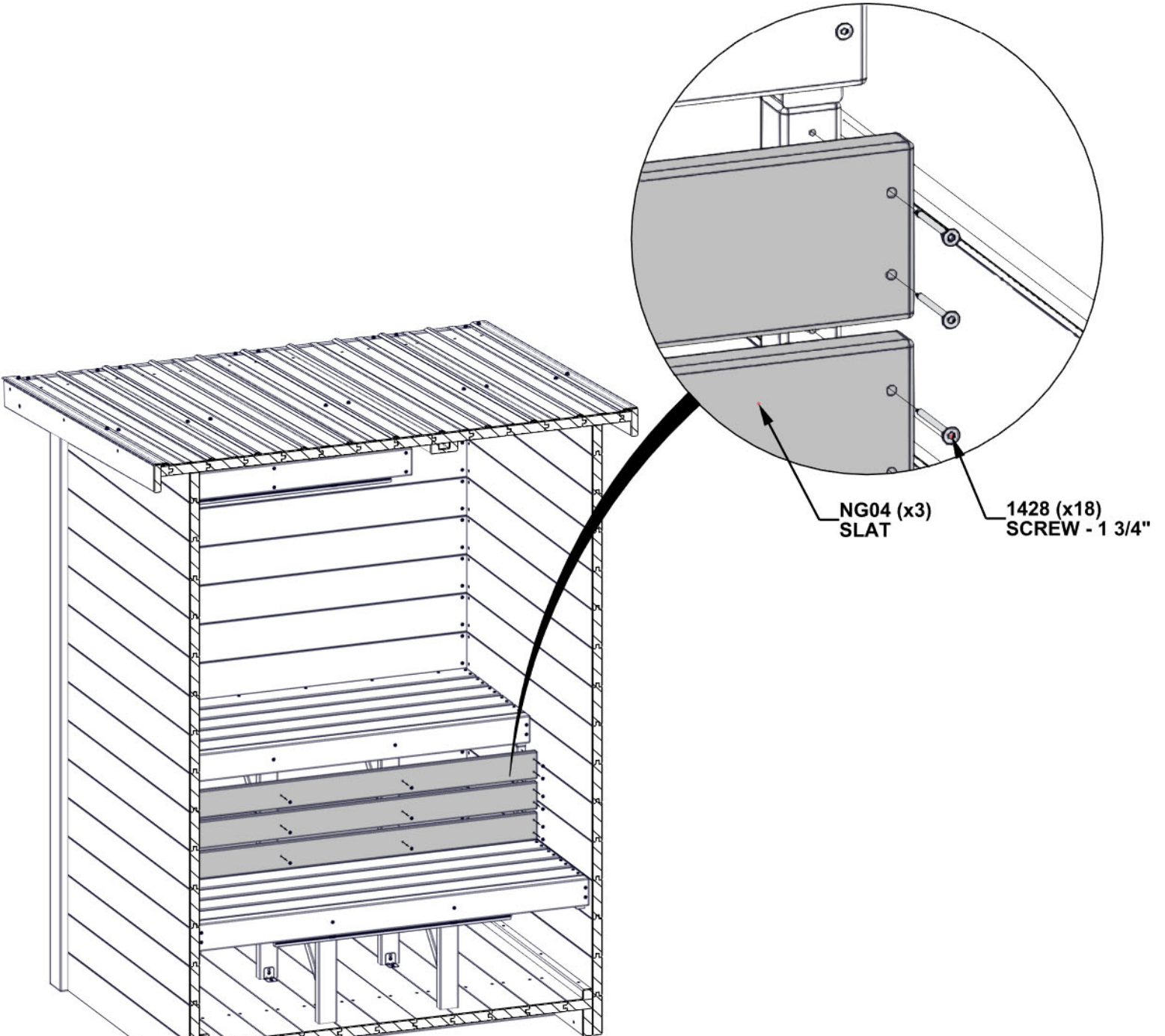

FRONT OF SAUNA HIDDEN FOR DETAIL

STEP 66 - GROMMET INSTALLATION

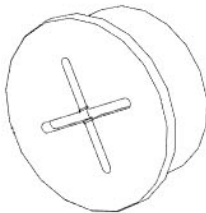

A6P01467 25mm SILICONE GROMMET
(x2)

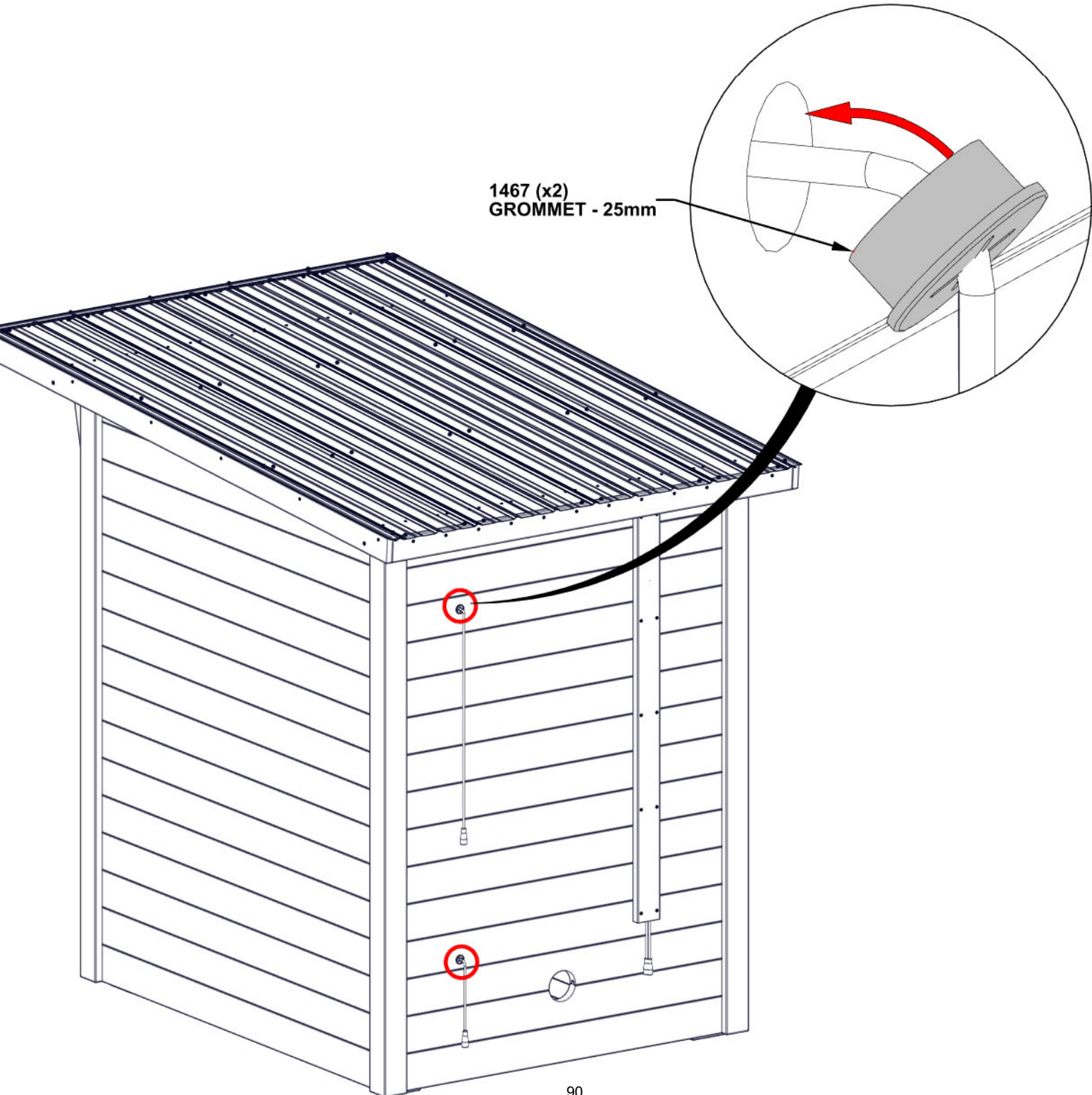

STEP 67 - CONTROL PANEL

QTY	PART NUMBER	DESCRIPTION
3	H101440	SCREW TWH 8x1 SS-BLK

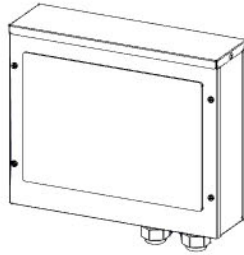

A4M05590-01 CONTROL PANEL BOX
(x1)

- REMOVE COVER PLATE FROM CONTROL PANEL BOX.
- USE DIMENSIONS TO LOCATE CONTROL PANEL BOX AND ATTACH AS SHOWN.
- REATTACH COVER PLATE.

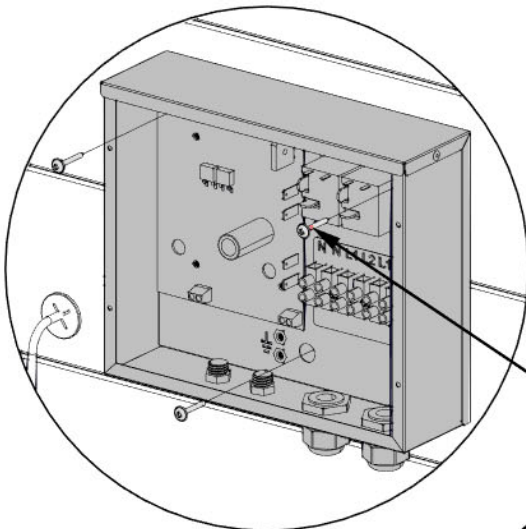
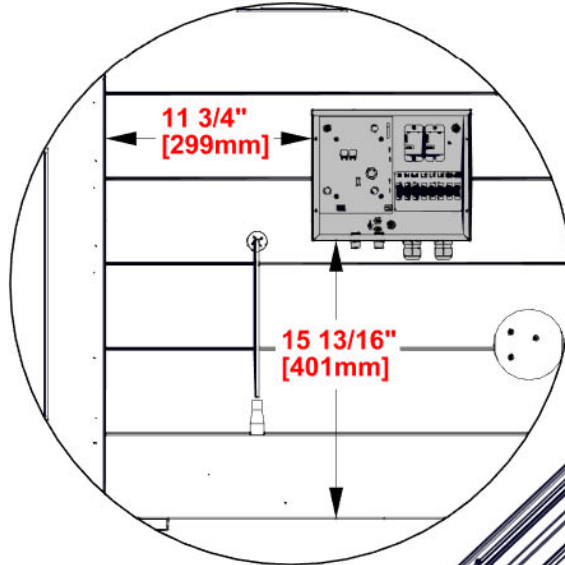

1440 (x3)
SCREW - 1"

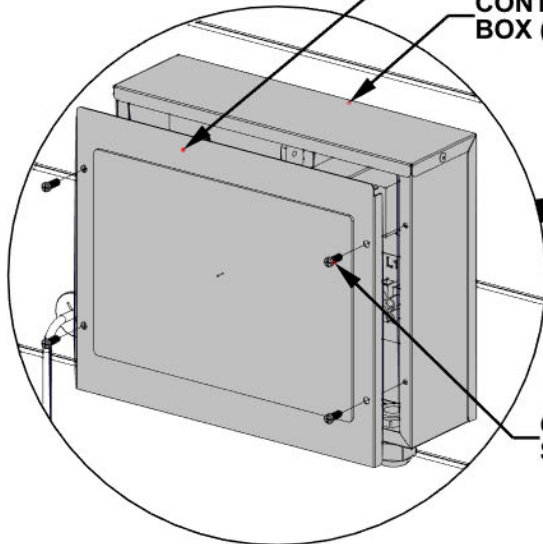

COVER PLATE

CONTROL PANEL
BOX (x1)

COVER PLATE
SCREWS

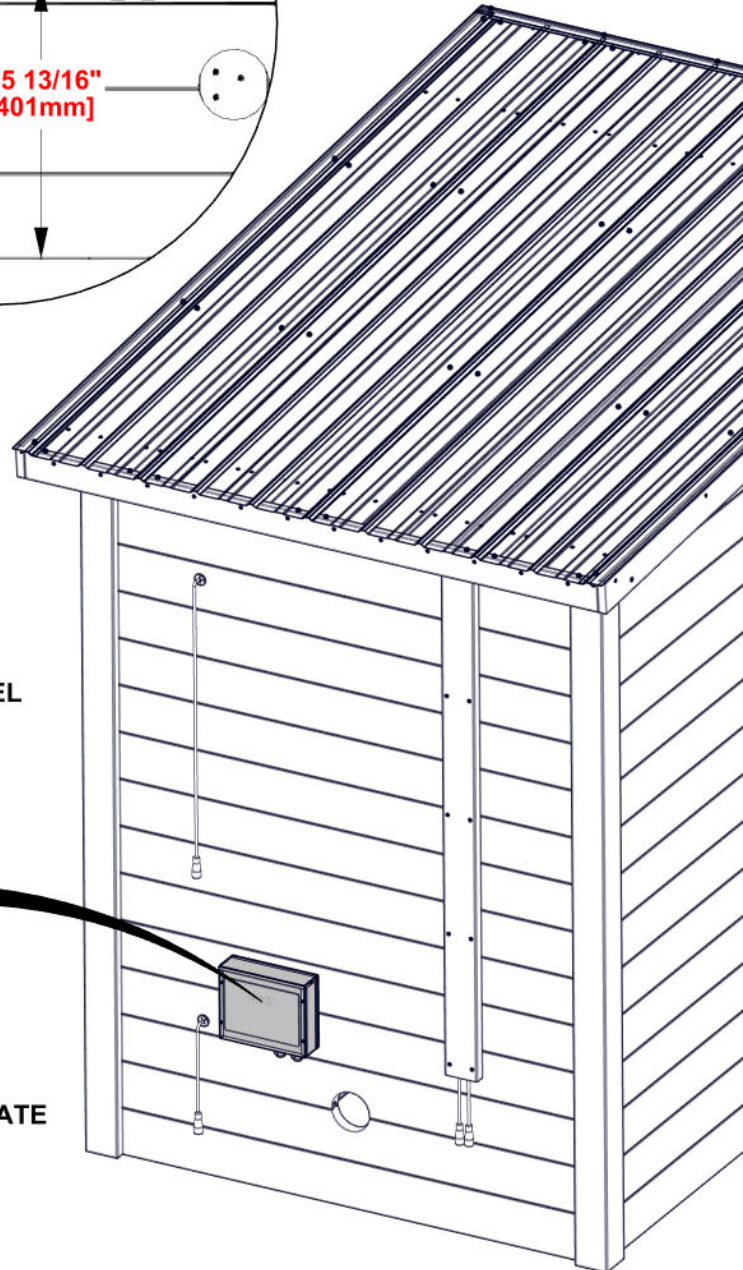

STEP 68 - LED LIGHT

QTY	PART NUMBER	DESCRIPTION
9	H101409	SCREW PPH 4x1/2 BLK
6	H101440	SCREW TWH 8x1 SS-BLK

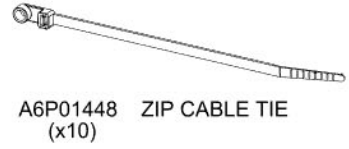
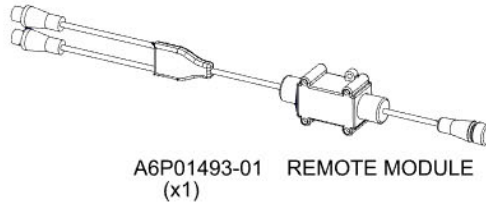
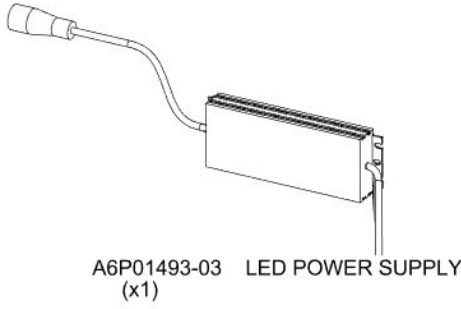

- LOCATE REMOTE MODULE AND POWER SUPPLY IN THE APPROXIMATE LOCATIONS.
- ENSURE REMOTE MODULE AND POWER SUPPLY ARE ORIENTED HORIZONTALLY WHEN ATTACHING.
- USE ZIP TIES WHERE NEEDED TO ATTACH AND ORGANIZE CORDS.

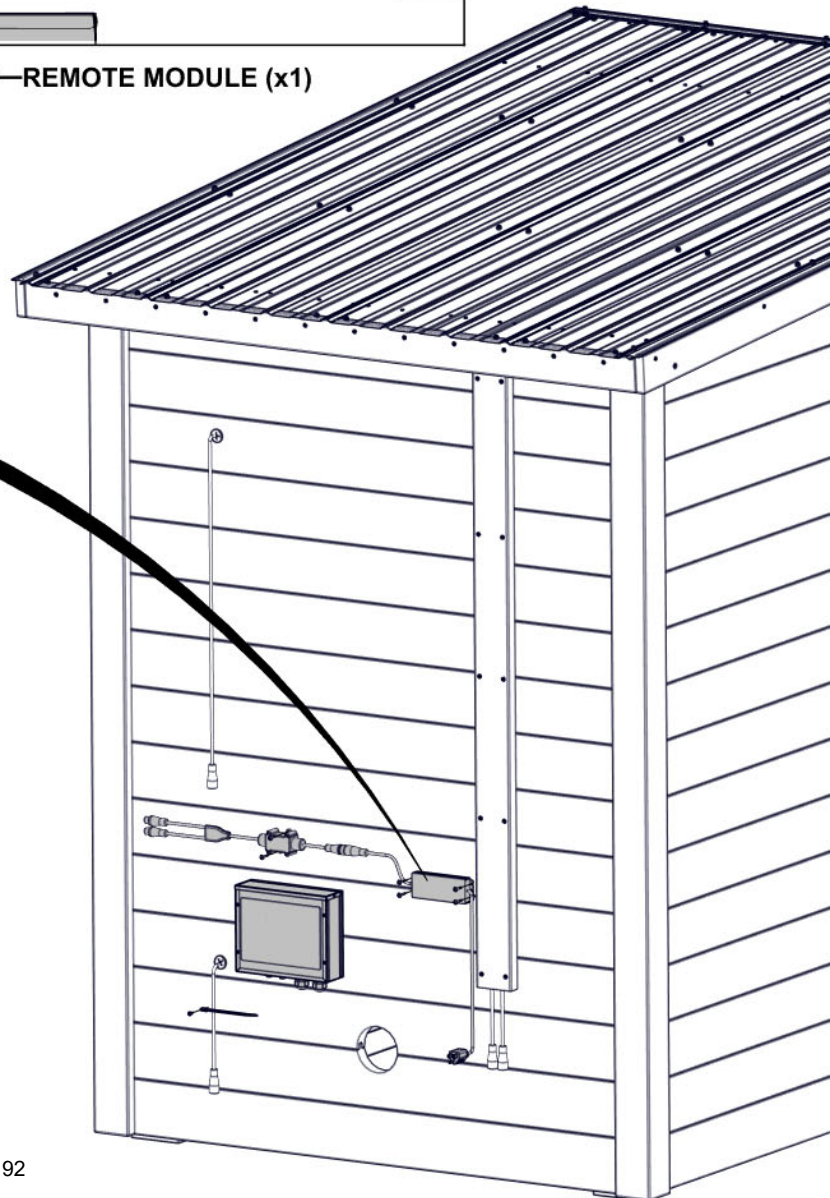
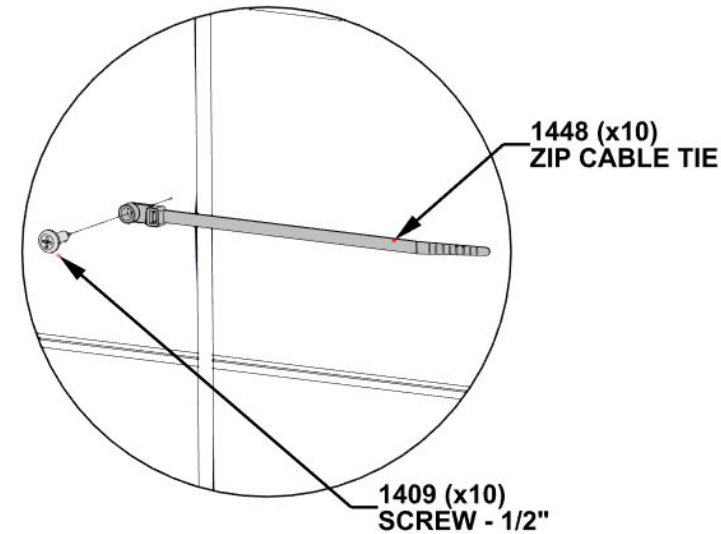
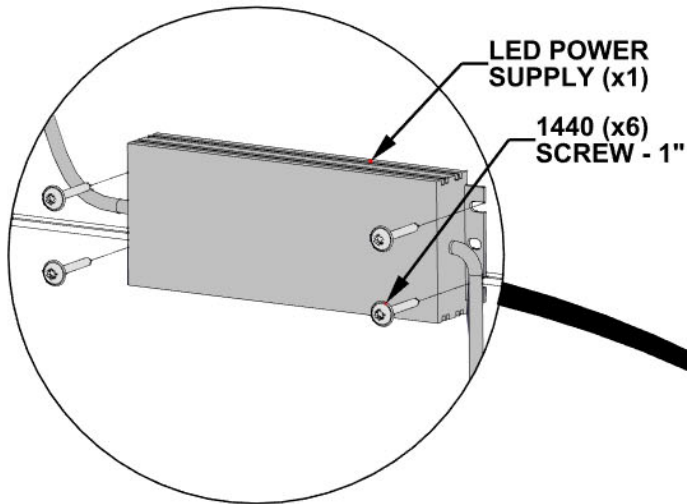
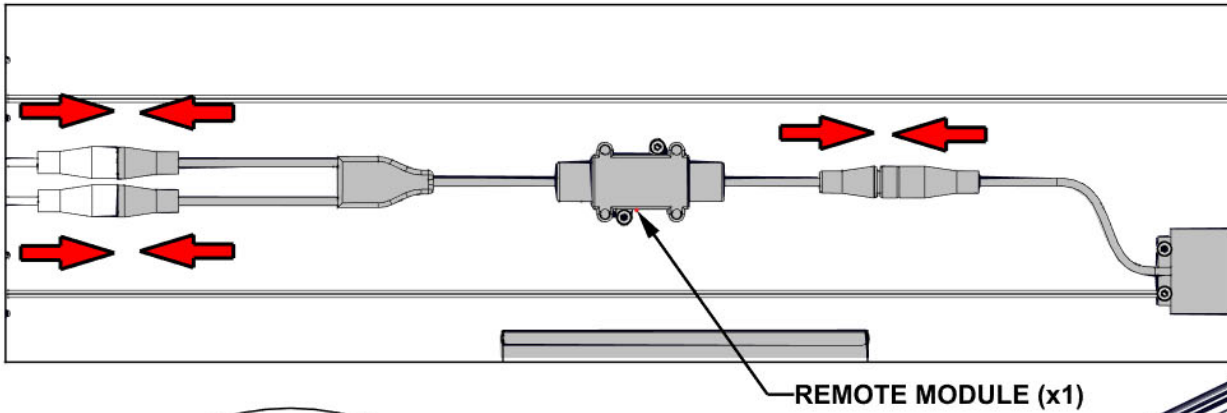

STEP 69 - VENT INSTALLATION

QTY	PART NUMBER	DESCRIPTION
3	H101424	SCREW TFH 8X1 SS-BLK
4	H101438	SCREW TWH 8X3/4 SS-BLK

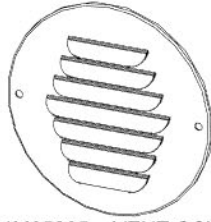

A4M05285 VENT COVER
(x2)

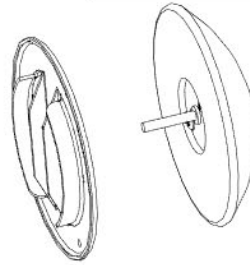

A4M05592 VENT ASSEMBLY
(x1)

- BEFORE ATTACHING VENT COVER, UNSCREW ADJUSTABLE VENT COVER FROM VENT BASE INSERT.
- ONCE VENT BASE INSERT IS ATTACHED, SCREW ADJUSTABLE VENT COVER BACK IN.

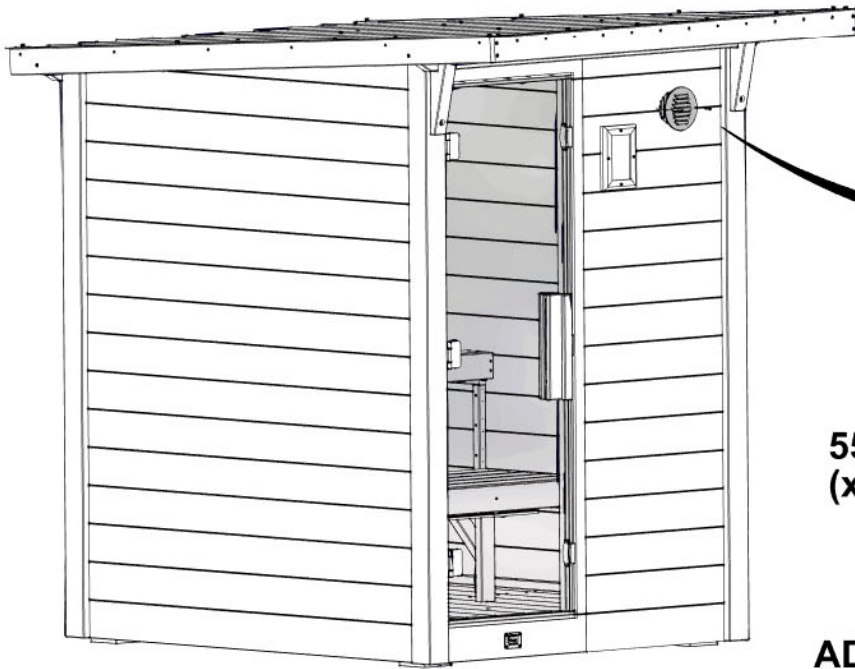

5285 (x2)
VENT

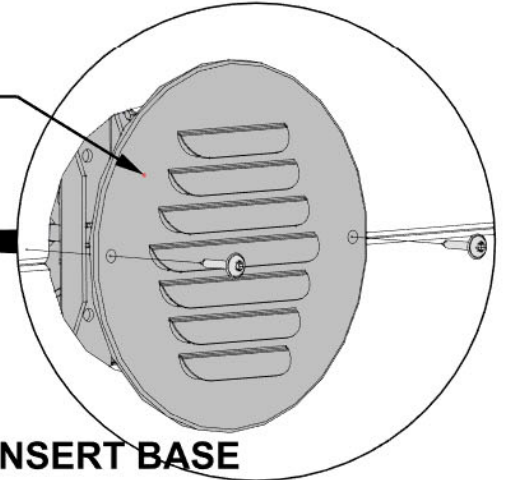

5592 VENT INSERT BASE
(x1)

1424 (x3)
SCREW - 1"

ADJUSTABLE
VENT COVER

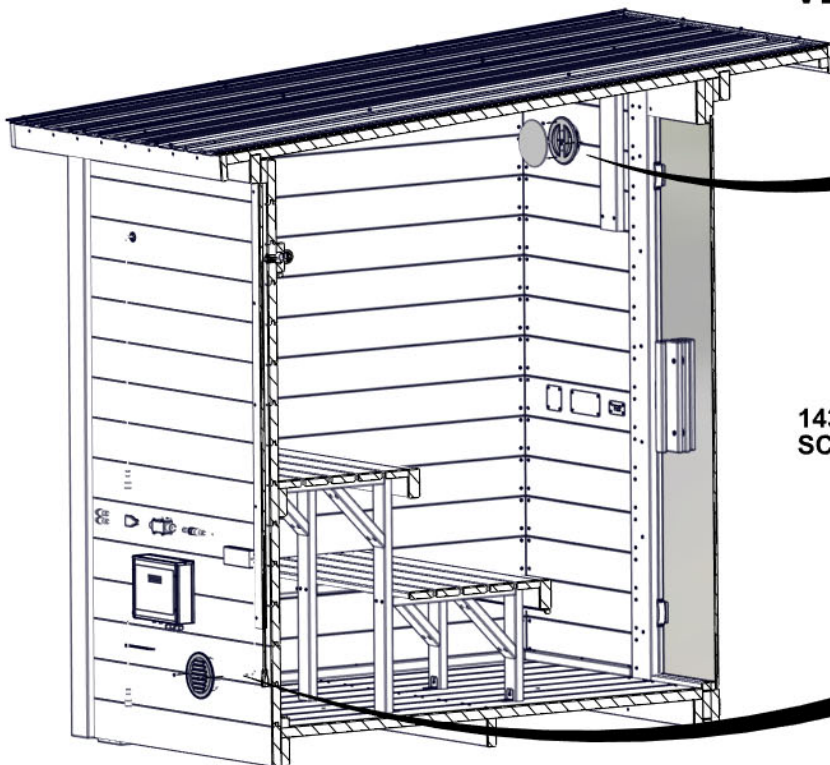
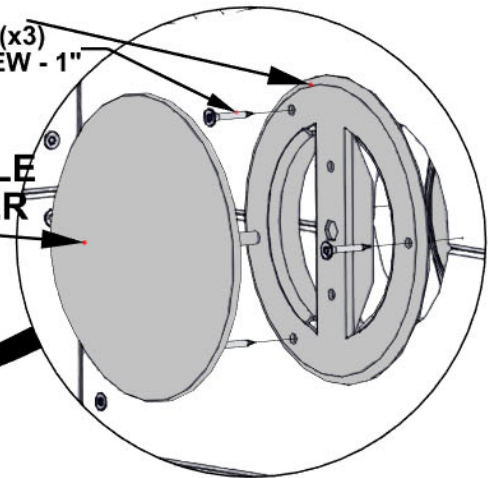

1438 (x4)
SCREW - 3/4"

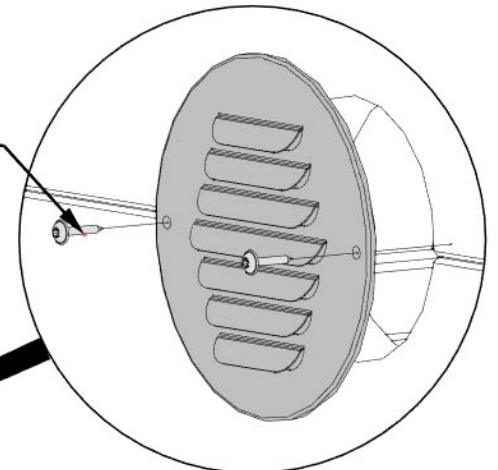

STEP 70 - TOWEL HANGER

QTY	PART NUMBER	DESCRIPTION
4	H100885	SCREW TFH BLK

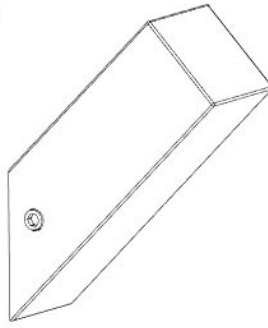

A4M05672-02 HANGER
(x2)

- INSTALL TOWEL HANGERS AT ANY DESIRE LOCATION ON THE RIGHT SIDE.
- HOWEVER, DO NOT INSTALL SCREWS AT THE SEAMS OF THE PANEL BOARDS.
- ENSURE TOWEL HANGERS ARE NOT TOO CLOSE TO THE DOOR WHEN FULLY OPEN TO AVOID CONTACT AND POTENTIAL BREAKAGE.

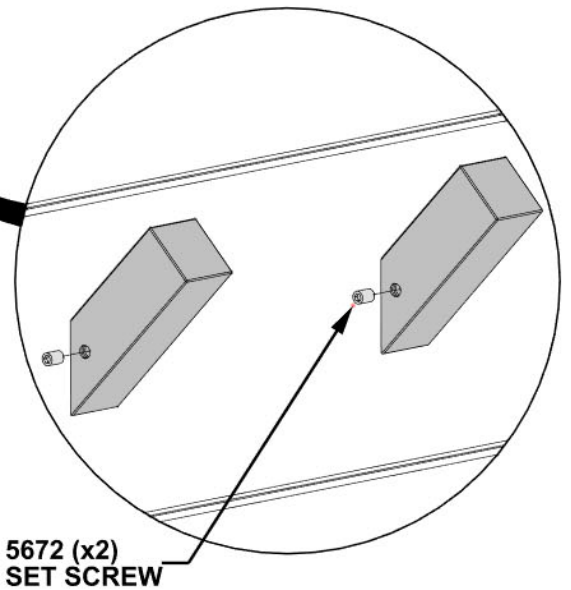
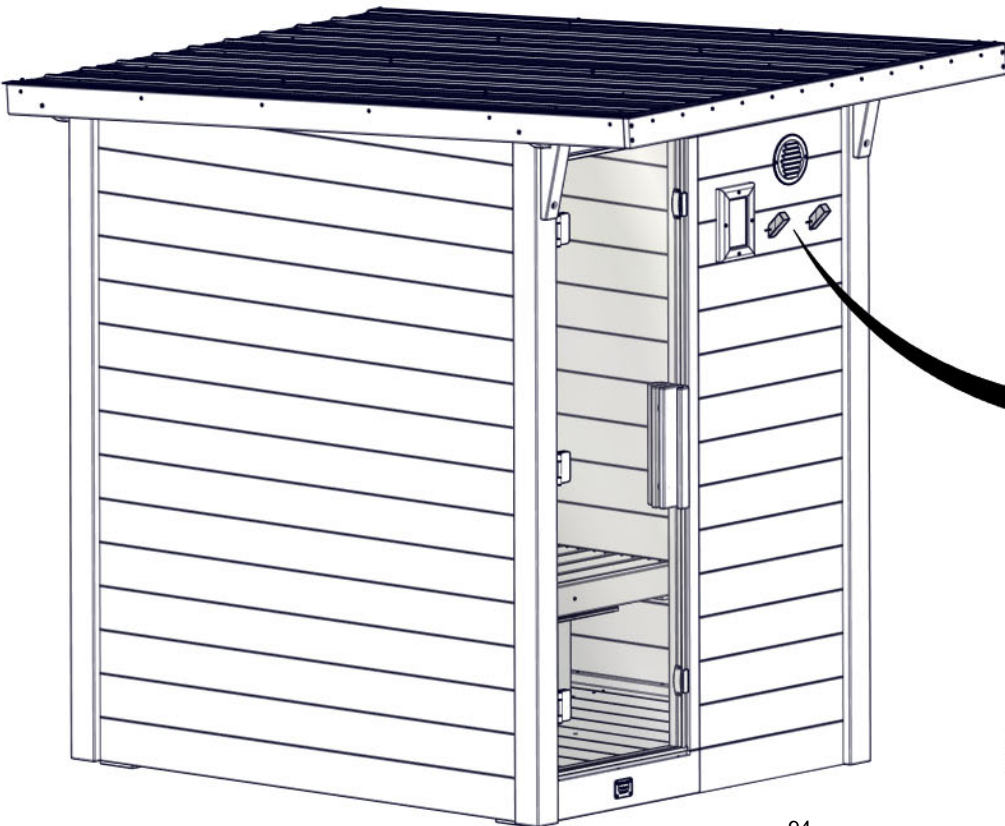
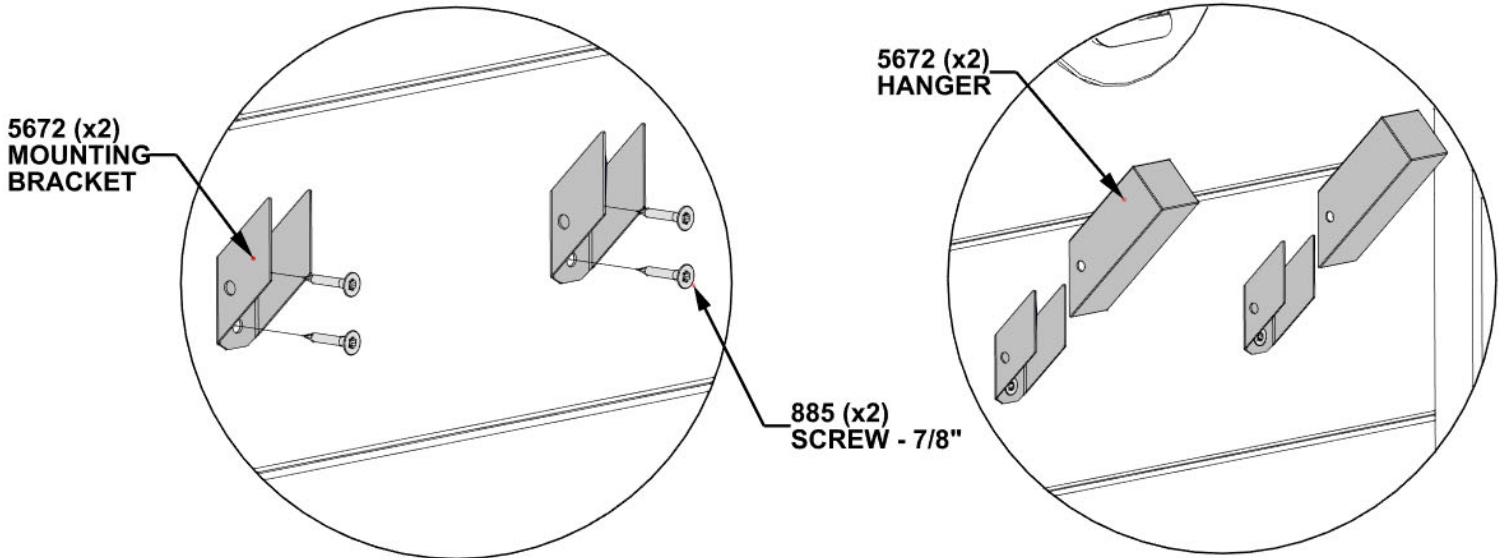

STEP 71 - THERMOMETER INSTALLATION

QTY	PART NUMBER	DESCRIPTION
1	H101424	SCREW TFH 8X1 SS-BLK

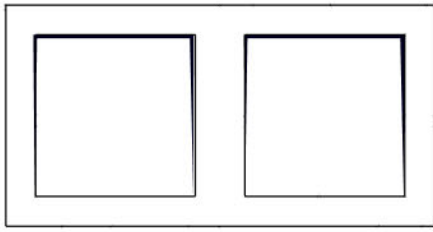

T01 THERMOMETER - W4L21965
(x1)

- INSERT SCREW INTO BACK WALL IN APPROXIMATE LOCATION SHOWN TO HANG THERMOMETER.

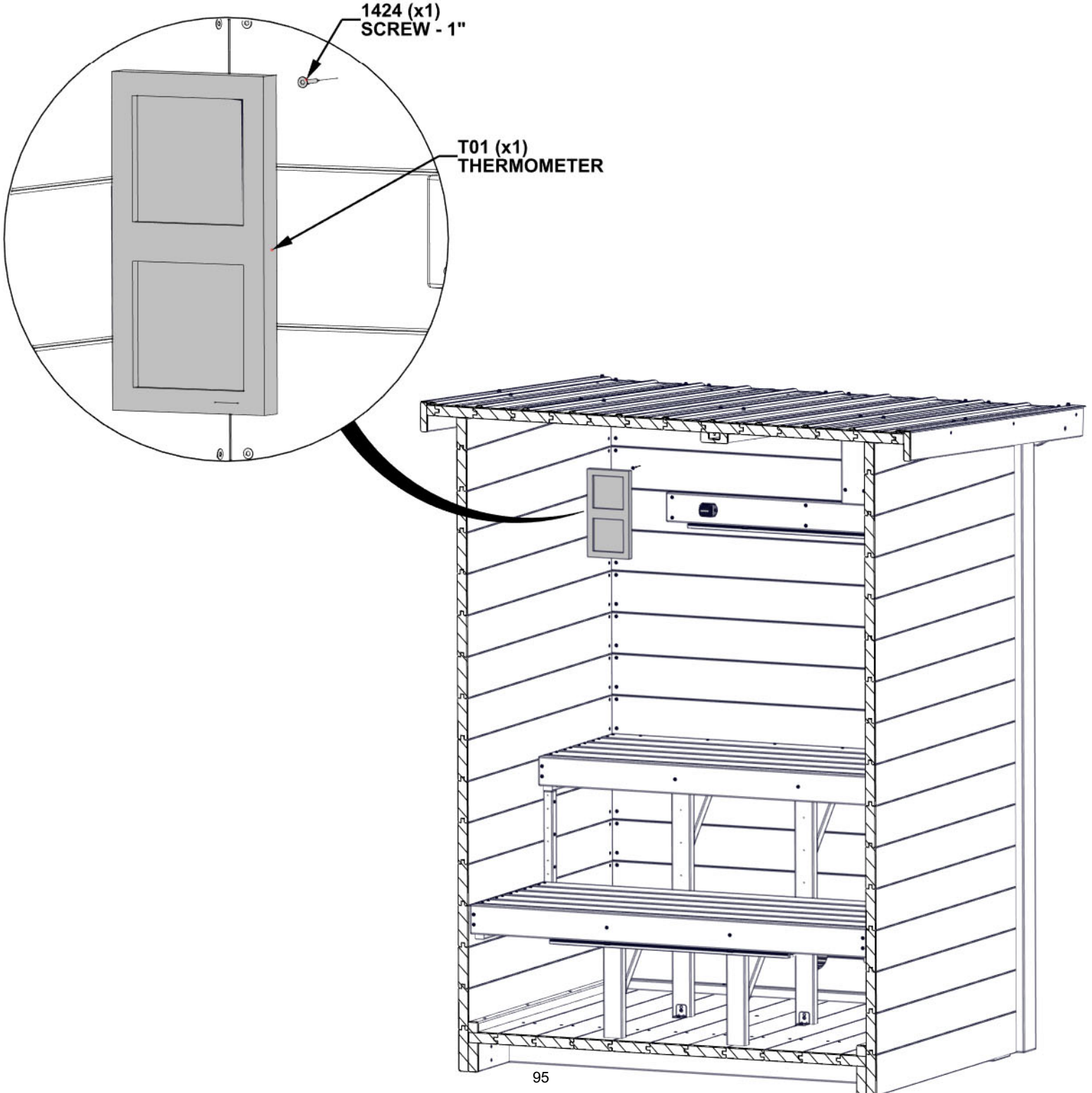

STEP 72 - FINISH

ONCE THE ASSEMBLY IS COMPLETE, SWEEP AND VACUUM THE INSIDE OF THE SAUNA. WIPE DOWN THE ENTIRE SAUNA WITH A DAMP CLOTH TO REMOVE ANY REMAINING DIRT, DUST, AND DEBRIS.

- DO NOT USE CHEMICAL-BASED CLEANING AGENTS INSIDE THE SAUNA.

