



Manufactured by:
Backyard Discovery
3305 Airport Drive, Pittsburg, KS 66762
800-856-4445

Basepoint Business Centre: Rivermead Drive, Westlea, Swindon SN5 7EX Phone: 0800-118-2476
J.P. Coenstraat 7, The Bridge, The Hague, 2595 WP, Netherlands Phone: 08005678990

14x10 CROSSWIND GAZEBO

MODEL #: 2506015



WARNING

Cancer and Reproductive Harm
www.P65Warnings.ca.gov



Please visit www.backyarddiscovery.com
For the most up to date assembly manual, to register your product, or to order
replacement parts Para obtener instrucciones en español, visite
www.backyarddiscovery.com



EASY STEP-BY-STEP
3D INTERACTIVE INSTRUCTIONS
DOWNLOAD THE FREE APP



OWNER'S MANUAL - BASIC SETUP DIMENSIONS & ASSEMBLY NOTES

It is critically important that you start with square and level footings or concrete pad to attach your structure.

- Pay close attention to the items needed for each step. Make sure you are using the correct hardware for each step. Using incorrect hardware may result in improper assembly
- Remember to double check for underground utilities and overhead electrical lines

Post mounts are provided with your structure which allows you to permanently install your structure to a pre-existing or new wood or concrete surface. See Anchor Instructions for further details and recommendations.

- The hardware to attach the post mounts to the structure is included.
- The hardware to mount the structure permanently to a concrete surface is included.
- The hardware to mount the structure permanently to a wood deck is NOT included and will need to be purchased separately. You must ensure there is ample structural support under the deck before permanently attaching.

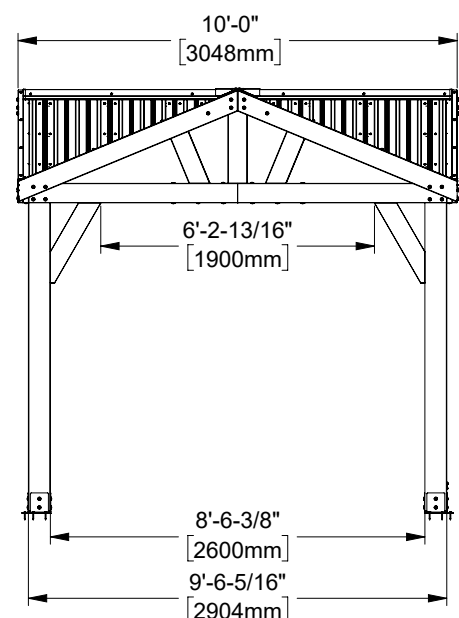
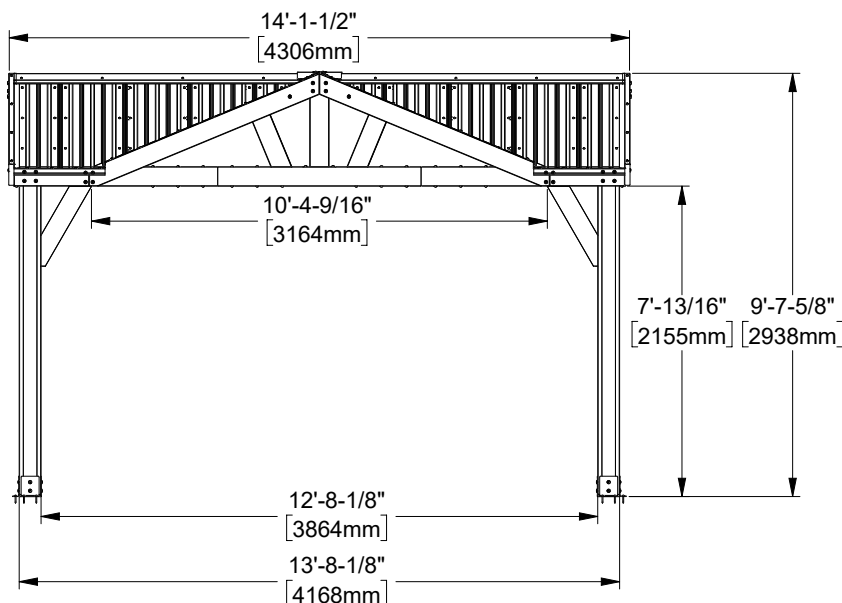
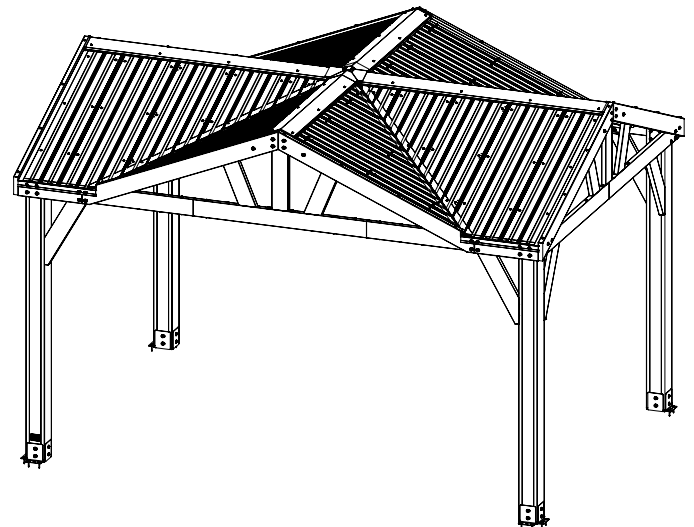
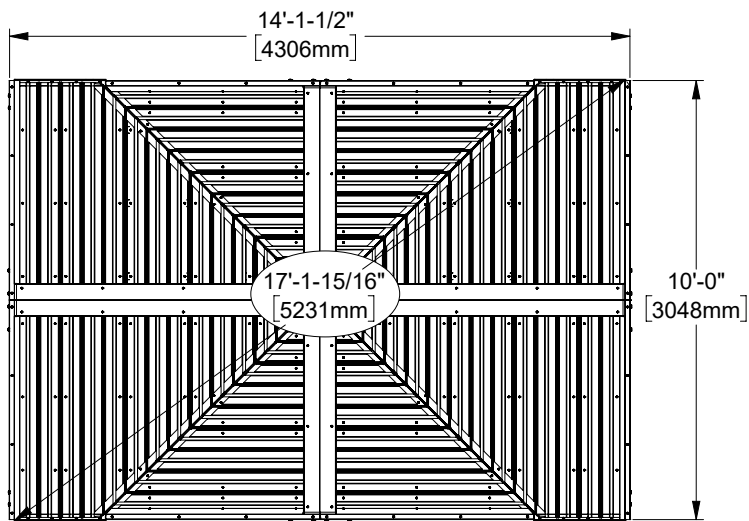

OWNER'S MANUAL - ANCHORING LAYOUT

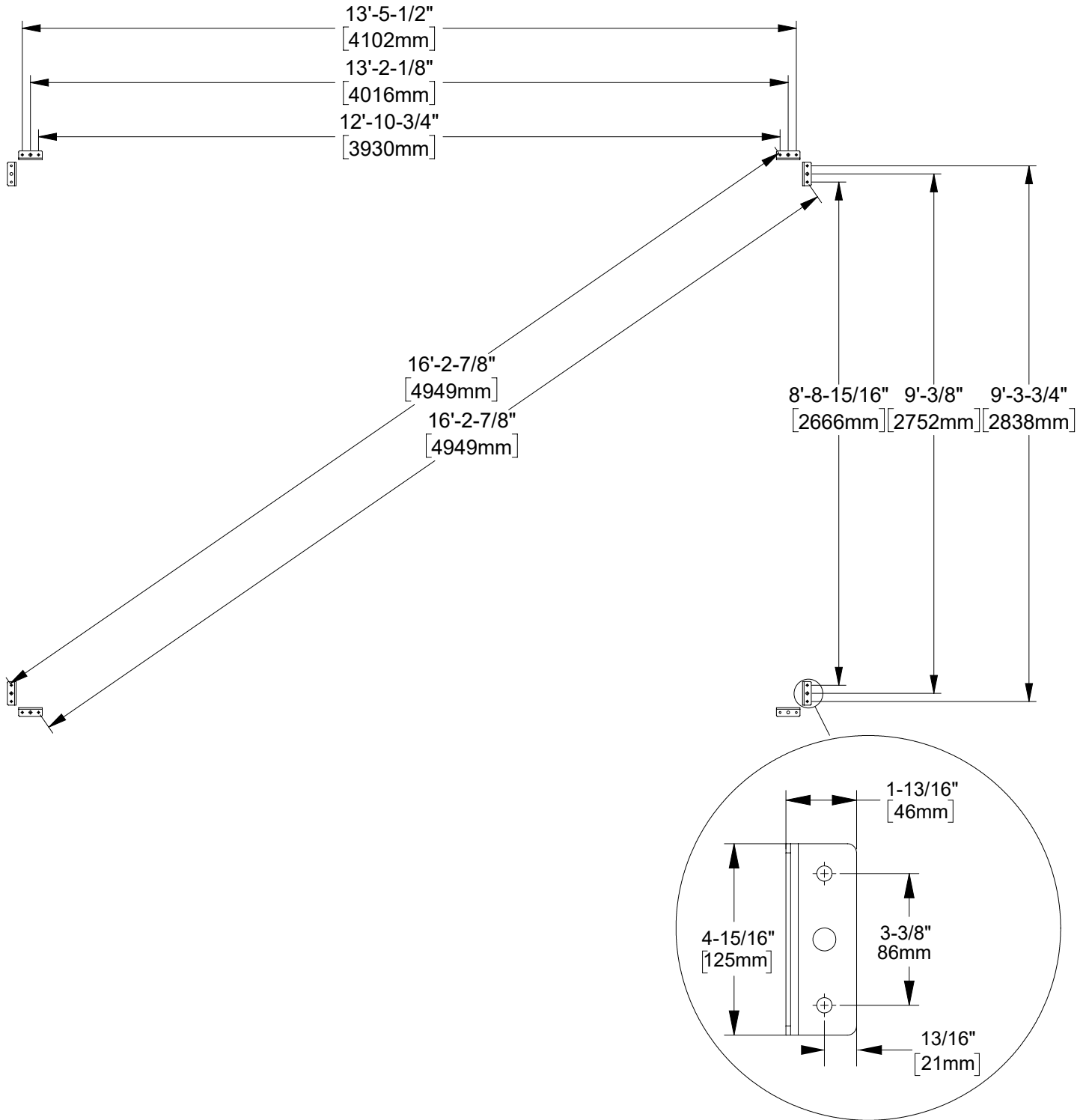

OWNER'S MANUAL - PARTS IDENTIFICATION

WOOD COMPONENTS (NOT TO SCALE)



D01 GABLE BOARD - W4L21706
(x2) 1 7/16"x5 1/4"x67 1/8" (36x134x1705)



D02 FASCIA BOARD - W4L21707
(x4) 1 7/16"x4 3/4"x20 1/2" (36x120x521)



D03 GABLE BOARD - W4L21708
(x2) 1 7/16"x5 1/4"x70 1/4" (36x134x1775)



D04 GABLE BOARD - W4L22267
(x2) 1 7/16"x5 1/4"x70 1/4" (36x134x1775)



D05 GABLE BOARD - W4L22268
(x2) 1 7/16"x5 1/4"x67 1/8" (36x134x1705)



H01 RIDGE BEAM - W4L21709
(x2) 15/16"x3 3/8"x89 1/2" (24x86x2274)



H02 RIDGE BEAM - W4L21710
(x2) 15/16"x3 3/8"x74 7/16" (24x86x1890)



H03 RIDGE BEAM - W4L21711
(x4) 15/16"x3 3/8"x56 1/16" (24x86x1424)



H04 SHEATHING BOARD - W4L21713
(x4) 15/16"x3 3/8"x77" (24x86x1956)



H05 SHEATHING BOARD - W4L21714
(x4) 15/16"x3 3/8"x57 1/16" (24x86x1450)



H06 SHEATHING BOARD - W4L21715
(x4) 15/16"x3 3/8"x37" (24x86x940)



H07 SHEATHING BOARD - W4L21729
(x4) 15/16"x3 3/8"x52 11/16" (24x86x1339)



H08 SHEATHING BOARD - W4L21730
(x4) 15/16"x3 3/8"x32 3/4" (24x86x832)



H09 SHEATHING BOARD - W4L22265
(x4) 15/16"x3 3/8"x12 1/8" (24x86x325)

OWNER'S MANUAL - PARTS IDENTIFICATION

WOOD COMPONENTS (NOT TO SCALE)

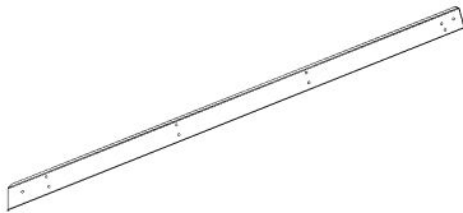

E01 VALLEY BOARD - W4L21712
(x2) 1 7/16"x3 3/8"x82 15/16" (36x86x2104)

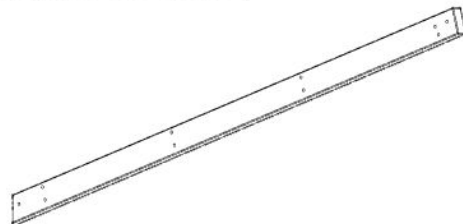

E15 VALLEY BOARD - W4L22269
(x2) 1 7/16"x3 3/8"x83 1/4" (36x86x2104)

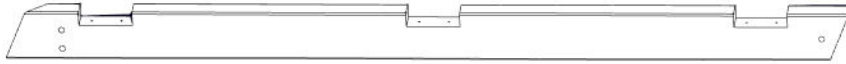

E02 RAFTER - W4L21716
(x2) 1 7/16"x3 3/8"x55 7/8" (36x86x1415)

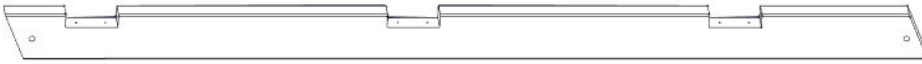

E03 RAFTER - W4L21717
(x4) 1 7/16"x3 3/8"x62 1/4" (36x86x1579)



E04 RAFTER - W4L21718
(x2) 1 7/16"x3 3/8"x38 9/16" (36x86x976)



E05 RAFTER - W4L21719
(x2) 1 7/16"x3 3/8"x21 1/4" (36x86x536)

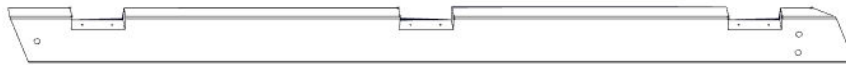

E06 RAFTER - W4L21720
(x2) 1 7/16"x3 3/8"x55 7/8" (36x86x1415)



E07 RAFTER - W4L21721
(x2) 1 7/16"x3 3/8"x38 9/16" (36x86x976)



E08 RAFTER - W4L21722
(x2) 1 7/16"x3 3/8"x21 1/4" (36x86x536)



E09 RAFTER - W4L21723
(x2) 1 7/16"x3 3/8"x56 9/16" (36x86x1432)



E10 RAFTER - W4L21724
(x2) 1 7/16"x3 3/8"x39 3/16" (36x86x992)



E11 RAFTER - W4L21725
(x2) 1 7/16"x3 3/8"x21 7/8" (36x86x552)



E12 RAFTER - W4L21726
(x2) 1 7/16"x3 3/8"x56 9/16" (36x86x1432)



E13 RAFTER - W4L21727
(x2) 1 7/16"x3 3/8"x39 3/16" (36x86x992)



E14 RAFTER - W4L21728
(x2) 1 7/16"x3 3/8"x21 7/8" (36x86x552)



P03 CLEAT - W4L22266
(x8) 1 7/16"x1 7/16"x57 1/8" (36x36x1450)



J01 RIDGE CAP STIFFENER - W4L22270
(x4) 1"X2 3/8"X78 1/2" (24x60x1993)



J02 RIDGE CAP STIFFENER - W4L22271
(x4) 1"X2 3/8"X53 1/2" (24x60x1360)



9205413 ELECTRICAL ENCLOSURE
(x1)

OWNER'S MANUAL - PARTS IDENTIFICATION

WOOD COMPONENTS (NOT TO SCALE)



P01 POST - W2A04716
(x2) 6"x6"x89 1/2" (152x152x2274)

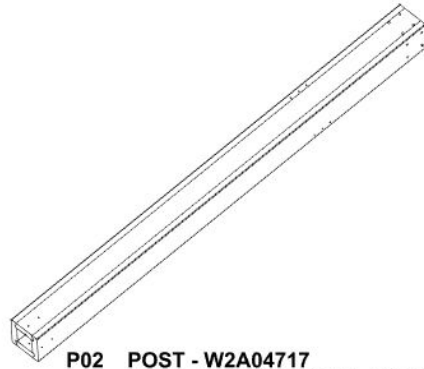

P02 POST - W2A04717
(x2) 6"x6"x89 1/2" (152x152x2274)

OWNER'S MANUAL - PARTS IDENTIFICATION

METAL COMPONENTS (NOT TO SCALE)



B01 BEAM - A4M05251
(x2) 1 7/16"x5 1/4"x55 5/8" (36x134x1412.53)



B02 BEAM - A4M05252
(x2) 1 7/16"x5 1/4"x55 5/8" (36x134x1412.53)



B03 BEAM - A4M05253
(x2) 1 7/16"x5 1/4"x55 9/16" (36x134x1411.33)



B04 BEAM - A4M5254
(x2) 1 7/16"x5 1/4"x57 1/8" (36x134x1450.7)



B05 BEAM - A4M05255
(x2) 1 7/16"x5 1/4"x57 1/8" (36x134x1450.7)



A4M02158 BYD ID TAG PATIO
(x1)



B06 VERTICAL GABLE SUPPORT - A4M05258
(x4) 1 7/16"x9 1/16"x22 3/16" (36x230x563.78)



J1 SPLICE BRACKET - A4M02230
(x6) 1 5/16"x5 3/16"x39 3/8" (33.2x131.2x1000)

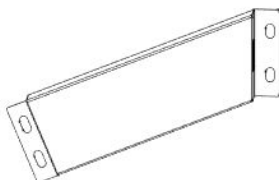

B07 GABLE SUPPORT - A4M05264
(x4) 1 7/16"x5 7/8"x18 1/2" (37x149x470)

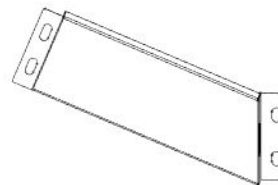

B08 GABLE SUPPORT - A4M05265
(x4) 1 7/16"x5 7/8"x18 1/2" (37x149x470)

OWNER'S MANUAL - PARTS IDENTIFICATION

METAL COMPONENTS (NOT TO SCALE)

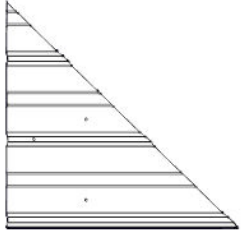

**A4M05907-2 29 GA STEEL SHEETING
(x2)**

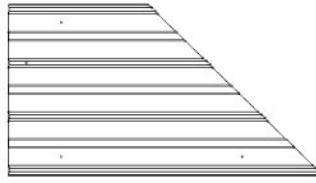

**A4M05907-1 29 GA STEEL SHEETING
(x2)**

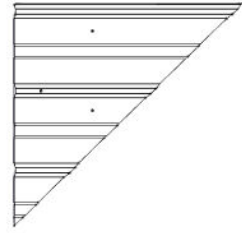

**A4M05908-2 29 GA STEEL SHEETING
(x2)**

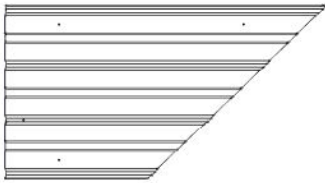

**A4M05908-1 29 GA STEEL SHEETING
(x2)**

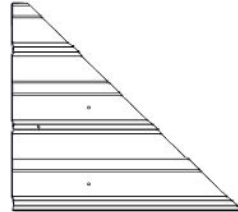

**A4M05909-2 29 GA STEEL SHEETING
(x2)**

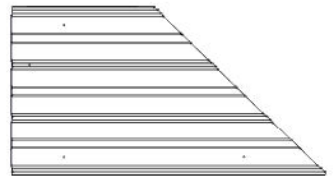

**A4M05909-1 29 GA STEEL SHEETING
(x2)**

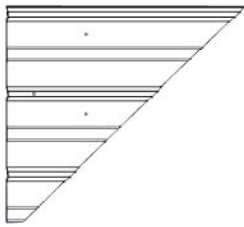

**A4M05910-2 29 GA STEEL SHEETING
(x2)**

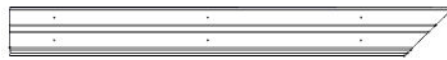

**A4M05911-1 29 GA SHEETING
(x2)**

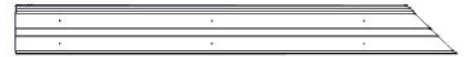

**A4M05911-2 29 GA SHEETING
(x2)**

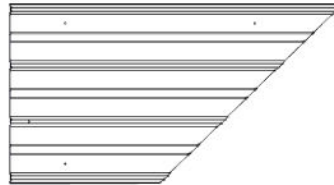

**A4M05910-1 29 GA STEEL SHEETING
(x2)**

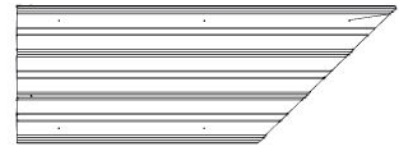

**A4M05786 29 GA SHEETING
(x2)**

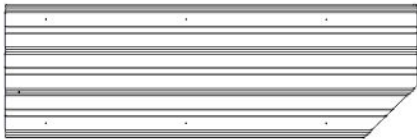

**A4M05256 29 GA SHEETING
(x2)**



**A4M05257 29 GA SHEETING
(x4)**



**A4M05789 29 GA SHEETING
(x2)**

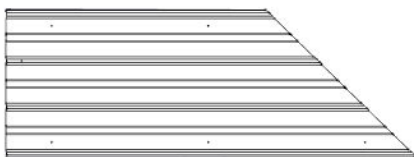

**A4M05790 29 GA SHEETING
(x2)**

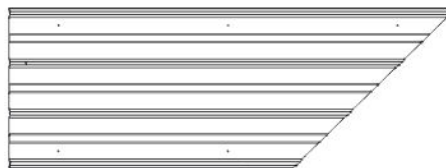

**A4M05793 29 GA SHEETING
(x2)**

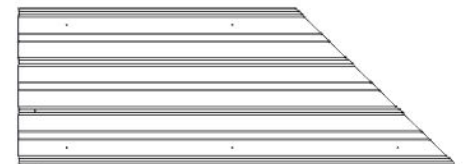

**A4M05842 29 GA SHEETING
(x2)**

OWNER'S MANUAL - PARTS IDENTIFICATION

METAL COMPONENTS (NOT TO SCALE)

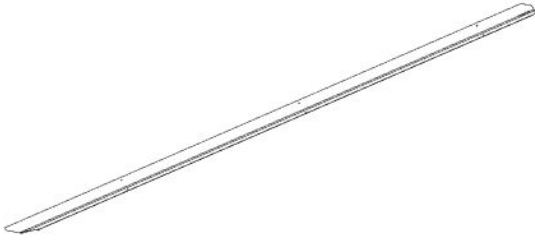

A4M05848 VALLEY FLASHING
(x2)

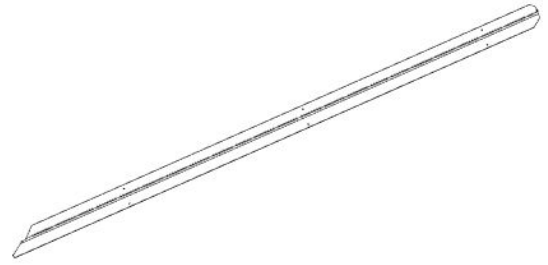

A4M05849 VALLEY FLASHING
(x2)

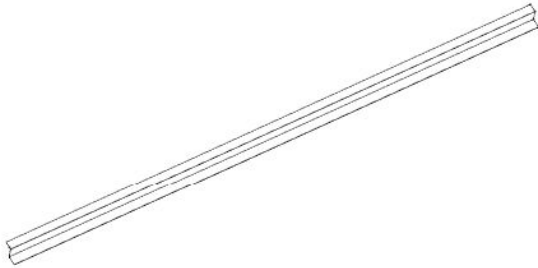

A4M05852 Z-TRIM
(x2)

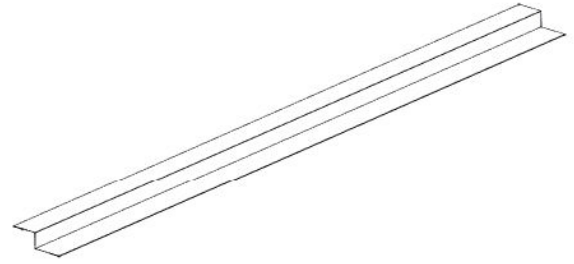

A4M05853 Z-TRIM
(x2)

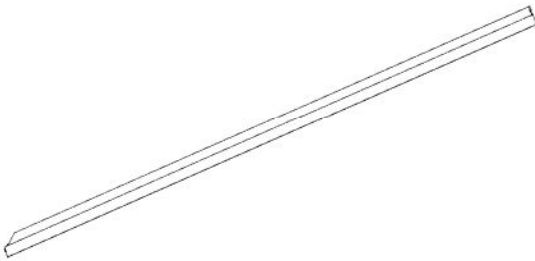

A4M05854 Z-TRIM
(x2)

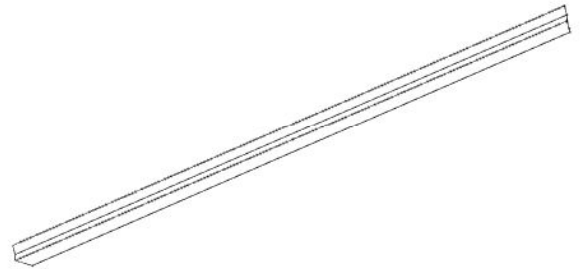

A4M05855 Z-TRIM
(x2)

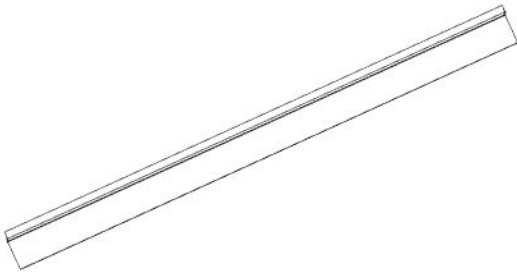

A4M05856 DRIP TRIM
(x4)

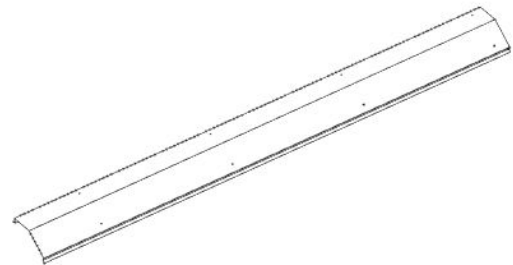

A4M05850 RIDGE CAP
(x2)

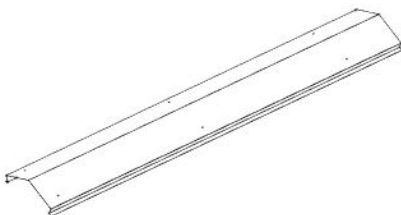

A4M05851 RIDGE CAP
(x2)



A4M05260 RIDGE BRACE
(x1)

OWNER'S MANUAL - PARTS IDENTIFICATION

METAL COMPONENTS (NOT TO SCALE)

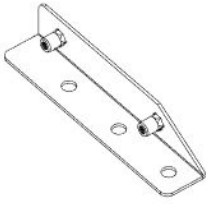

C01 ANGLE BRACE BRACKET - A4M04148
(x4) 1 1/16"x1 3/16"x6" (27x30x152)

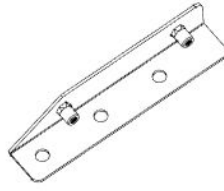

C02 ANGLE BRACE BRACKET - A4M04153
(x4) 1 1/16"x1 3/16"x6" (27x30x152)

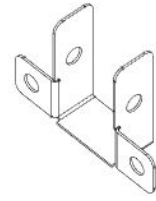

A4M01148 TRUSS BRACKET
(x6)



C03 BRACE - A4M05262
(x3) 1 7/16"x5 15/16"x27 1/8" (36x151x688)



C04 BRACE - A4M05263
(x4) 1 7/16"x5 15/16"x27 1/8" (36x151x688)



C05 BRACE WITH TAG - A4M05860
(x1) 1 7/16"x5 15/16"x27 1/8" (36x151x688)

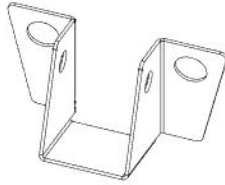

A4M05267 RAFTER BRACKET
(x4)

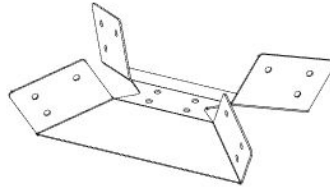

A4M04103 RIDGE TIE BRACKET
(x1)

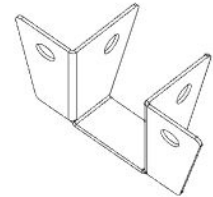

A4M05266 RAFTER BRACKET
(x28)



A4M05857 SUPPORT RING
(x4)

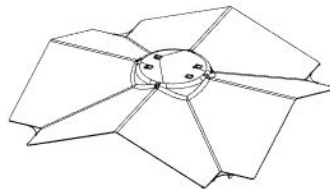

A4M05858 RIDGE CAP SPLICE
(x1)

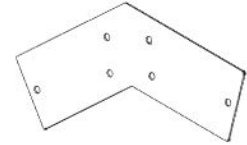

A4M05859 GABLE BRACKET
(x4)

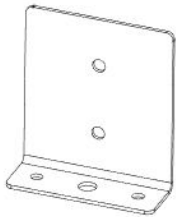

**A4M00977 POST ANCHORING
PLATE WITH FLANGE**
(x8)

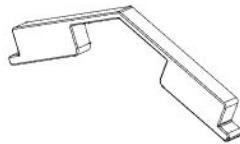

A6P00398 RIDGE CAP PROTECTOR
(x8)

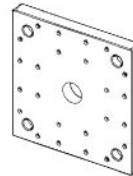

A6P00308 6x6 POST FOOT
(x4)

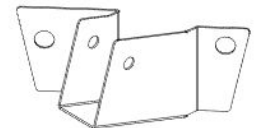

A4M05847 VALLEY CLIP
(x2)

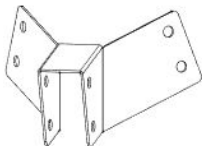

A4M05845 RAFTER TIE
(x12)

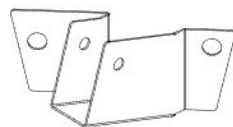

A4M05846 VALLEY CLIP
(x2)



A4M00978 POST PLATE
(x8)

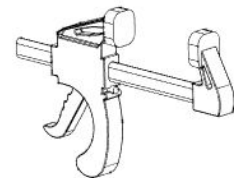

A6P00460 6\"/>

OWNER'S MANUAL - PARTS IDENTIFICATION

HARDWARE COMPONENTS

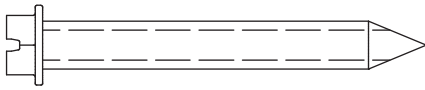

H100120 | CONCRETE ANCHOR
(x16) | 1/4"x2" BLK

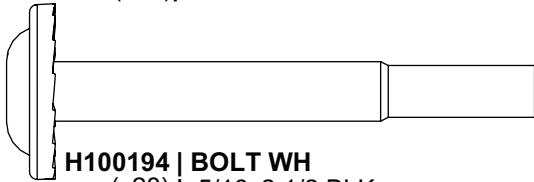

H100194 | BOLT WH
(x28) | 5/16x2 1/2 BLK

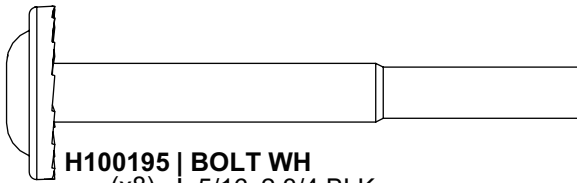

H100195 | BOLT WH
(x8) | 5/16x2 3/4 BLK

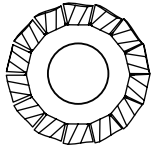

H100198 | WASHER LOCK EXT
(x48) | 8x19 BLK

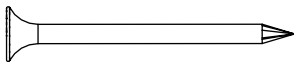

H100200 | SCREW PFH
(x16) | 8x1 1/2 BLK

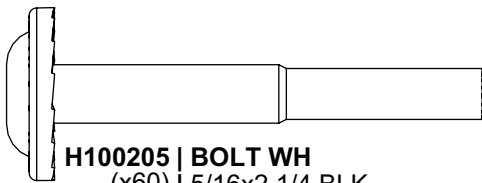

H100205 | BOLT WH
(x60) | 5/16x2 1/4 BLK

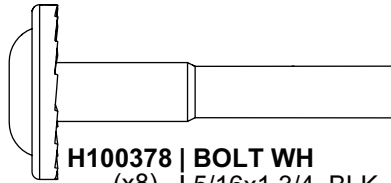

H100378 | BOLT WH
(x8) | 5/16x1 3/4 BLK

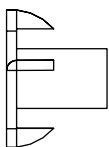

H100379 | T-NUT
(x104) | 5/16 BLK

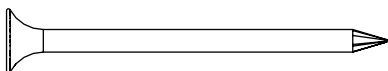

H100391 | SCREW PFH
(x168) | 8x2 BLK

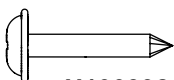

H100392 | SCREW PFH
(x36) | 8x3/4 BLK

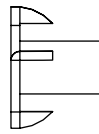

H100398 | T-NUT
(x12) | 1/4 BLK

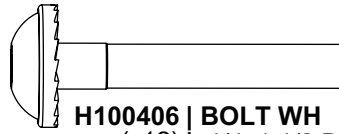

H100406 | BOLT WH
(x12) | 1/4x1 1/2 BLK

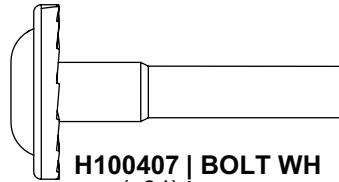

H100407 | BOLT WH
(x64) | 5/16x1 1/2 BLK

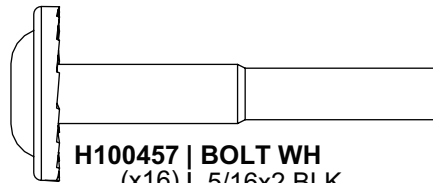

H100457 | BOLT WH
(x16) | 5/16x2 BLK

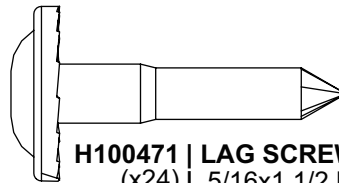

H100471 | LAG SCREW WH
(x24) | 5/16x1 1/2 BLK

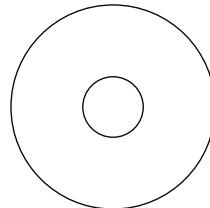

H100478 | WASHER FLAT
(x32) | 8x27 BLK



H100479 | NUT LOCK
(x104) | 5/16 BLK

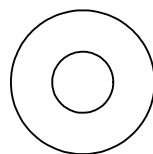

H100630 | WASHER FLAT
(x20) | 8x19 BLK

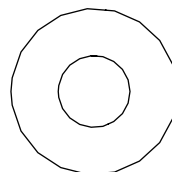

H100770 | WASHER FLAT
(x72) | 9.5x22 BLK

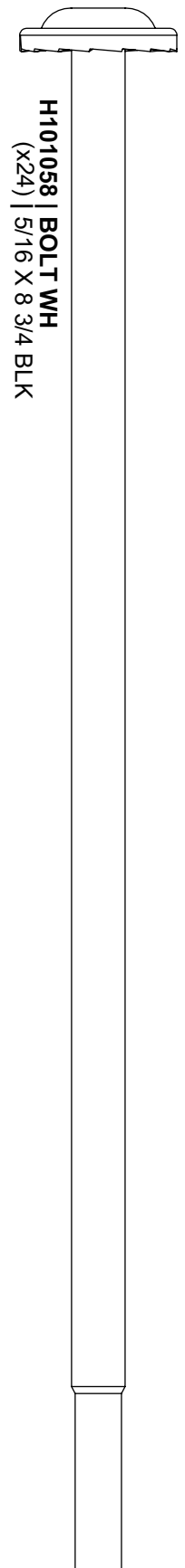

H101058 | BOLT WH
(x24) | 5/16 X 8 3/4 BLK

OWNER'S MANUAL - PARTS IDENTIFICATION

HARDWARE COMPONENTS

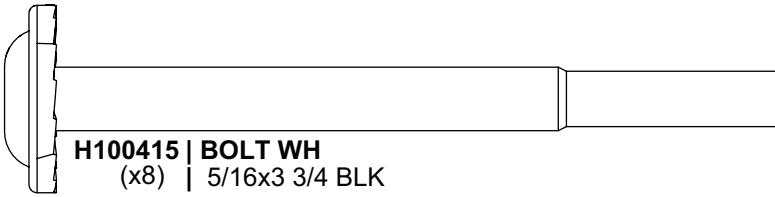

H100415 | BOLT WH
(x8) | 5/16x3 3/4 BLK

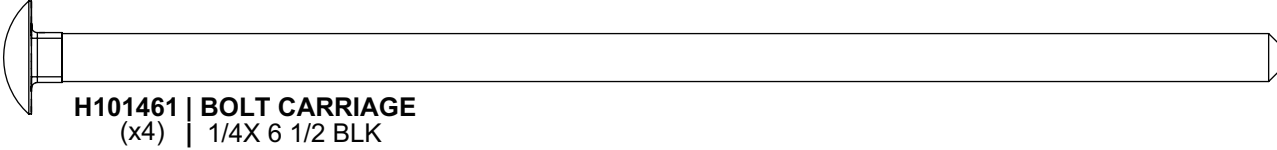

H101461 | BOLT CARRIAGE
(x4) | 1/4X 6 1/2 BLK

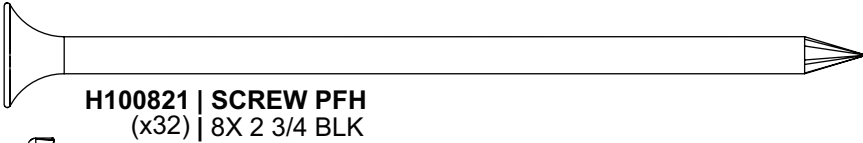

H100821 | SCREW PFH
(x32) | 8X 2 3/4 BLK

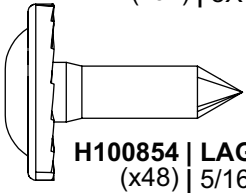

H100854 | LAG SCREW WH
(x48) | 5/16X 1 BLK

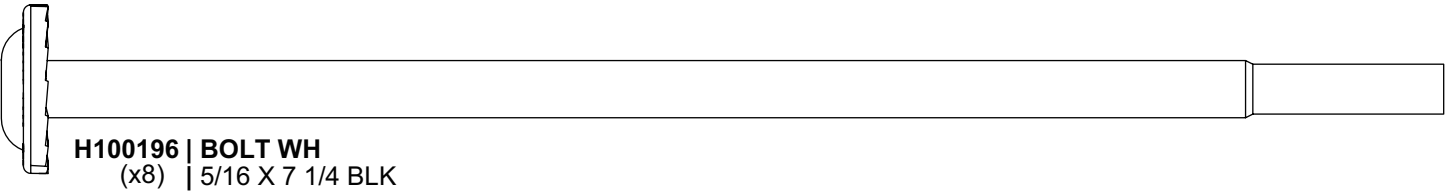

H100196 | BOLT WH
(x8) | 5/16 X 7 1/4 BLK

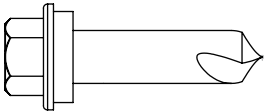

H101116 | SCREW SELF TAPPING
(x48) | 1/4x1 BLK

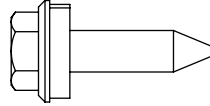

H101117 | SCREW WOODGRIP
(x204) | 10-16 x 3/4 BLK

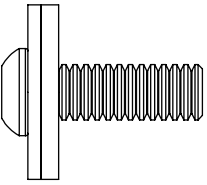

H101202 | TORX PAN HEAD
(x140) | 1/4-20x3/4 ASSY



H100653 | NUT LOCK
(x4) | 1/4 BLK

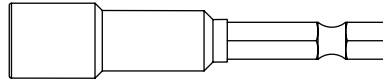

H101106 | SOCKET DRIVER
(x1) |

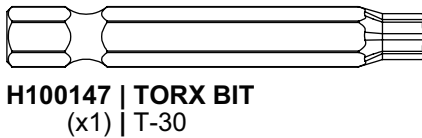

H100147 | TORX BIT
(x1) | T-30

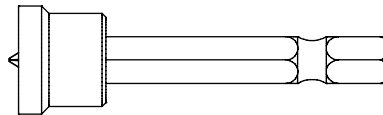

H100764 | SCREW SETTER
(x1) |

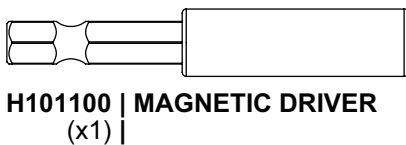

H101100 | MAGNETIC DRIVER
(x1) |

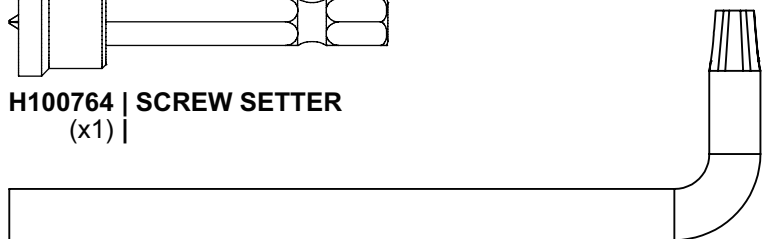

H100114 | TORX BIT
(x1) | T-30

PRE-ASSEMBLY STEP 1 - SORTING PARTS

It is critical for ease of assembly that you take the time to sort and organize the parts and hardware.

METAL PARTS:

- Organize metal parts by the three-digit, alpha-numeric number stamped on each part (ex. P01).
- If there are multiple parts with the same stamped number, stack those pieces together.
- Stamps can be found on the flat surface of the parts or on the end of the parts.
- Allow yourself plenty of room - the parts can take up a significant amount of space.

NOTE: CARTONS ARE NOT ORGANIZED BY PART OR STEP NUMBER.

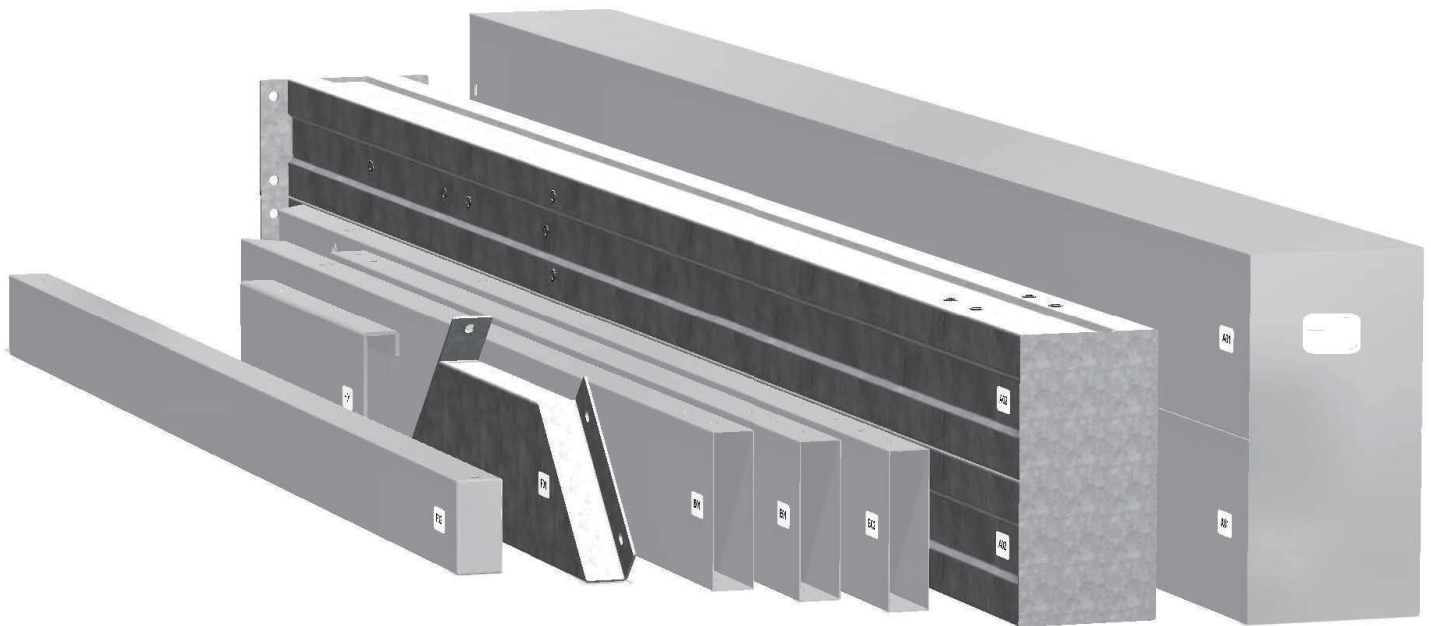

HARDWARE PARTS:

- We recommend that you have a separate table to organize the hardware.
- Hardware bags are printed with a seven-digit, alpha-numeric part number.
- You can organize your hardware by part number or group by hardware type (e.g. bolts, nuts, etc.).
- During assembly you only need to reference the last four digits of the number.

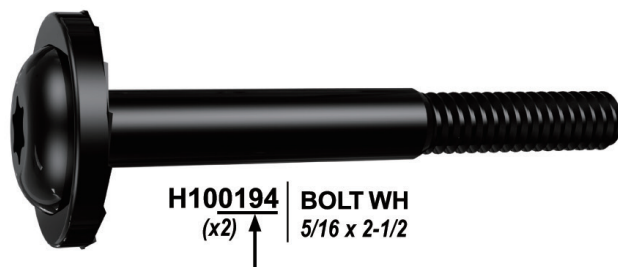

PRE-ASSEMBLY STEP 2 - TOOLS REQUIRED



Cordless Drill or
Electric Drill



Drill Attachments:
Phillips Head



1/8", 3/16", 3/8" &
7/16" Drill Bits



Phillips Screw Driver

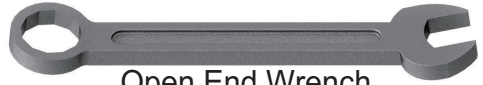

Open End Wrench
7/16"



3/8" Drive Ratchet, 1/2" &
7/16" STD Sockets 1/2" & 7/16"
Deep Sockets



Claw Hammer



Rubber Mallet -
Optional

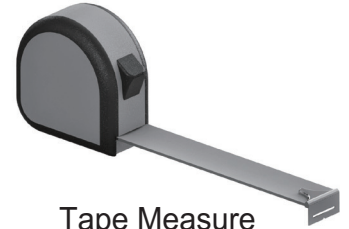

Tape Measure

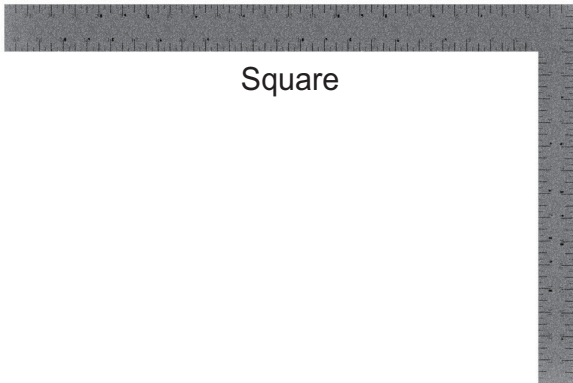

Square



Level 24"

PRE-ASSEMBLY STEP 3 - CHOOSE YOUR ASSEMBLY METHOD

There are several types of assembly instructions available to you.

1. Printed Assembly Manual included with your set
2. BILT APP - 3D interactive instructions
3. Combination of the Printed Manual and BILT APP (Note: Step numbers can differ between the two methods)

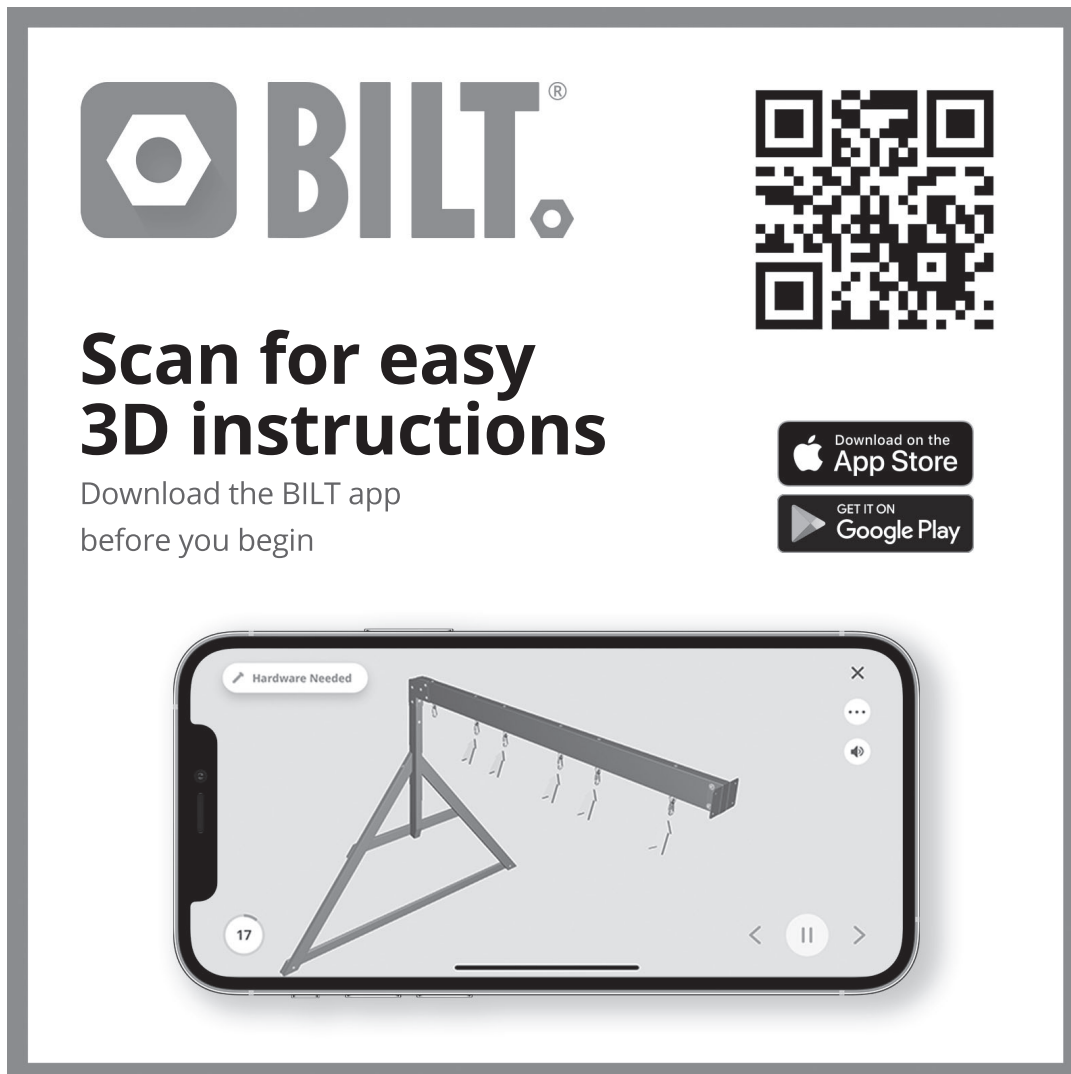

The graphic is a rectangular frame containing the BILT logo (a hexagon with a dot inside) and the word "BILT." with a registered trademark symbol. To the right is a large QR code. Below the logo is the text "Scan for easy 3D instructions" and "Download the BILT app before you begin". To the right of this text are two buttons: "Download on the App Store" and "GET IT ON Google Play". At the bottom is a smartphone displaying a 3D assembly instruction for a metal frame, with a "Hardware Needed" label, a page number "17", and navigation icons.

STEP 1 - POST ASSEMBLY

Qty	PartNo	Description
16	H100200	SCREW PFH 8X 1 /12 BLK



P01 POST - W2A04716
(x2) 6"x6"x89 1/2" (152x152x2274)



P02 POST - W2A04717
(x2) 6"x6"x89 1/2" (152x152x2274)

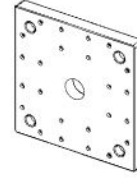

A6P00308 6x6 POST FOOT
(x4)

- ALIGN POST FOOT AND DRILL 1/8" [3mm] PILOT HOLES FOR THE ATTACHMENT OF HARDWARE.
- REPEAT THIS STEP 4 TIMES.

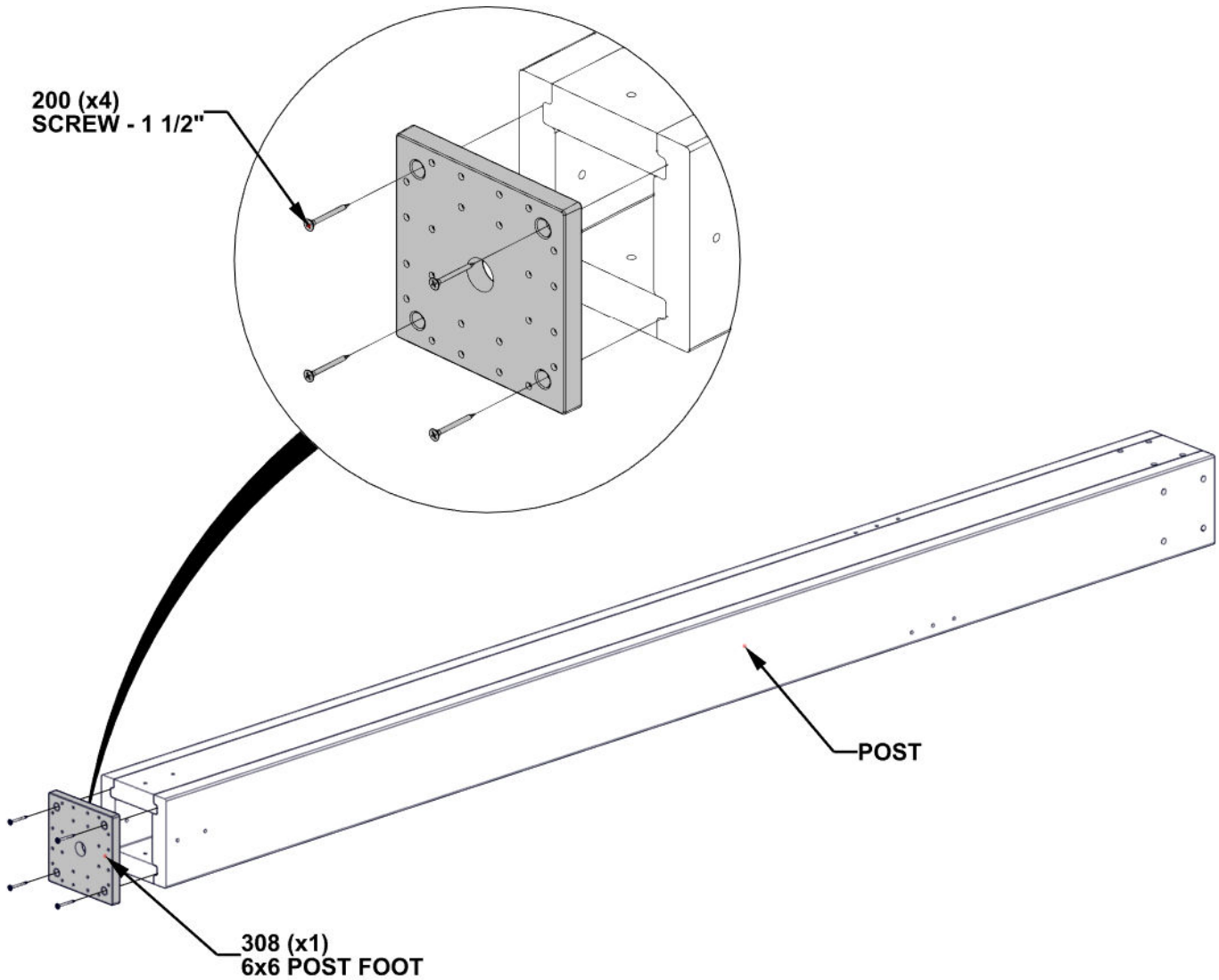

STEP 2 - POST ASSEMBLY

Qty	PartNo	Description
32	H100379	TNUT-5/16" BLK

- INSERT T-NUT.
- REPEAT FOR 4 POST ASSEMBLIES IN THIS STEP.

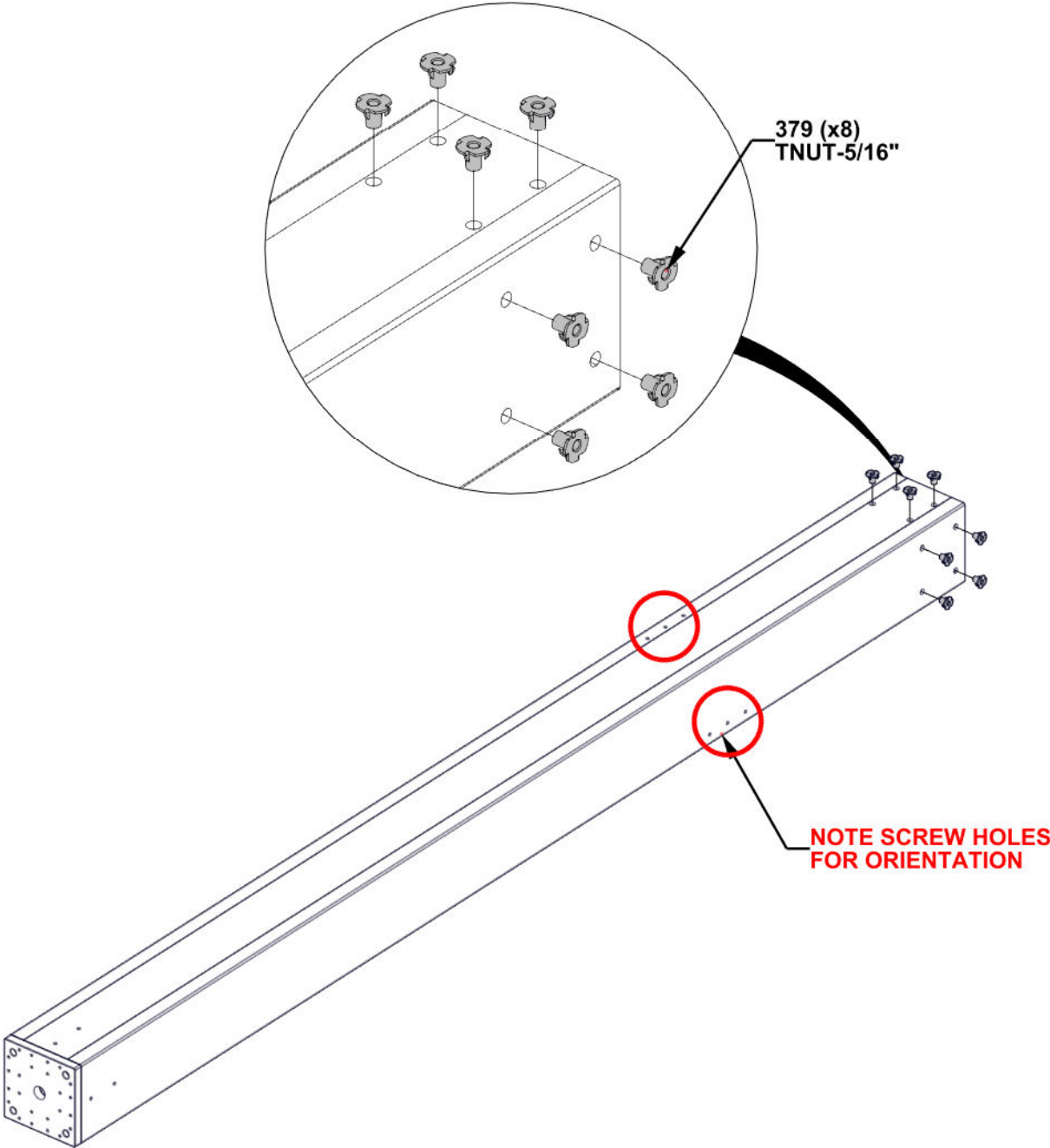

STEP 3 - POST ASSEMBLY

Qty	PartNo	Description
24	H100471	LAG SCREW WH 5/16x1 1/2 BLK

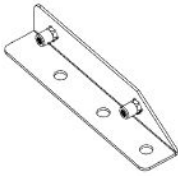

C01 ANGLE BRACE BRACKET - A4M04148
(x4) 1 1/16"x1 3/16"x6" (27x30x152)

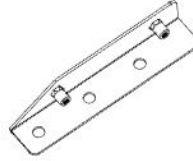

C02 ANGLE BRACE BRACKET - A4M04153
(x4) 1 1/16"x1 3/16"x6" (27x30x152)

- ALIGN SCREW HOLES.

- REPEAT FOR 4 POST ASSEMBLIES IN THIS STEP.

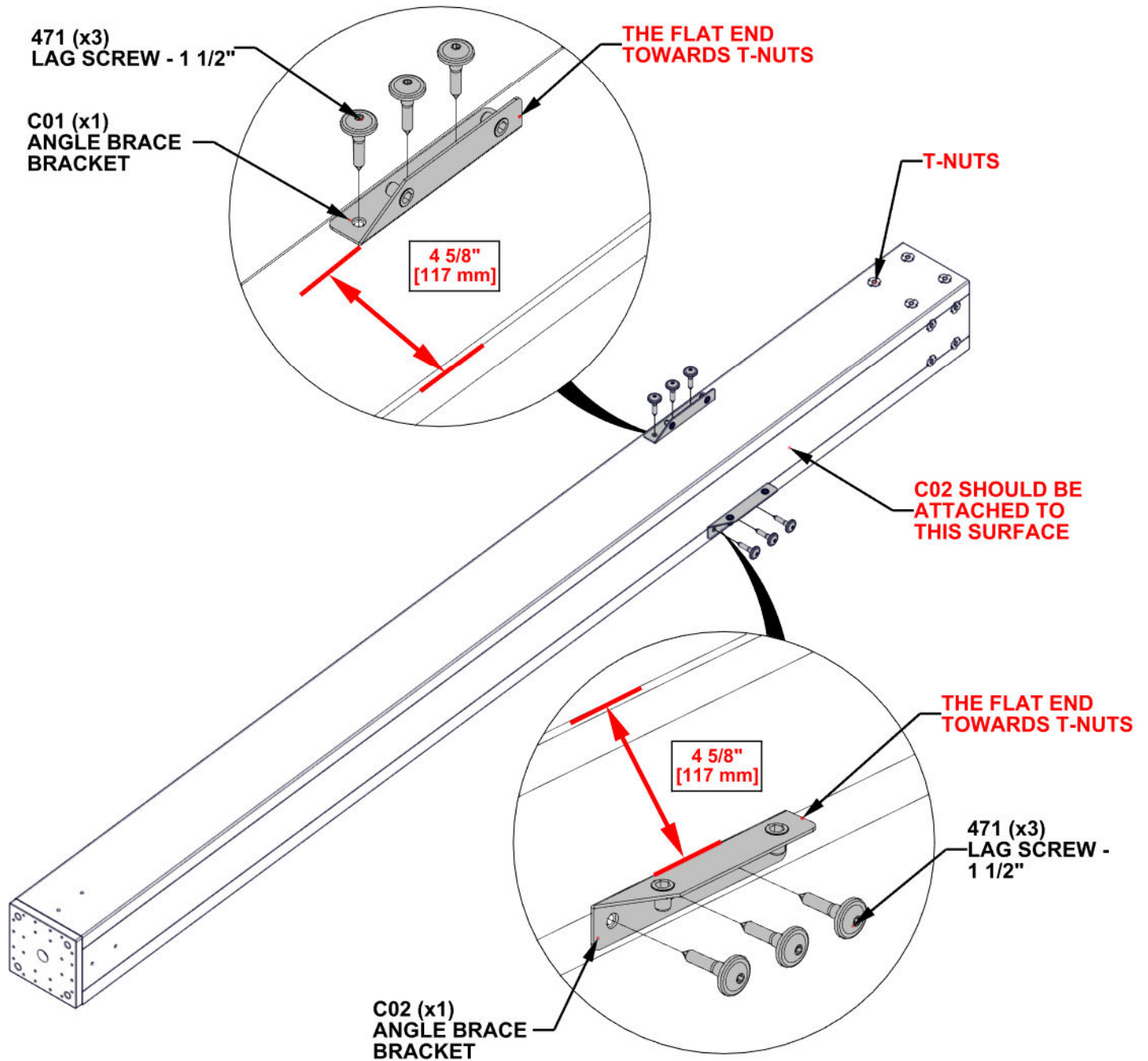

STEP 4A - POST ASSEMBLY

Qty	PartNo	Description
4	H101202	TORX PAN HEAD 1/4-20x3/4 ASSY



C05 BRACE WITH TAG - A4M05860
 (x1) 1 7/16"x5 15/16"x27 1/8" (36x151x688)



C04 BRACE - A4M05263
 (x1) 1 7/16"x5 15/16"x27 1/8" (36x151x688)

- INSERT BRACES ONTO ANGLE BRACE BRACKETS ON P02.

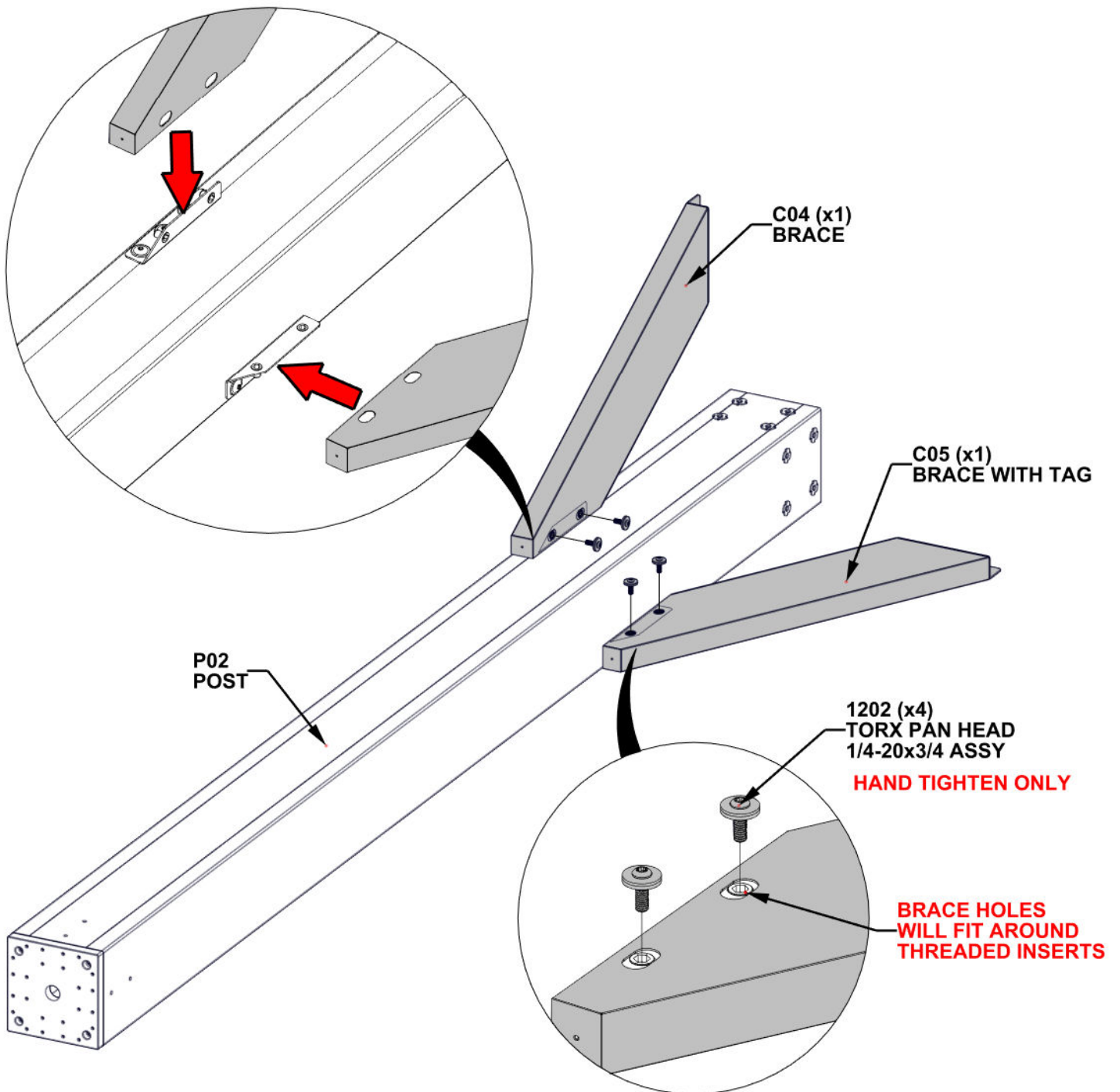

STEP 4B - POST ASSEMBLY

Qty	PartNo	Description
12	H101202	TORX PAN HEAD 1/4-20x3/4 ASSY

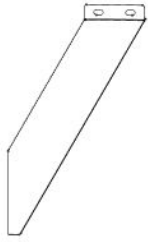

C03 BRACE - A4M05262
(x3) 1 7/16"x5 15/16"x27 1/8" (36x151x688)



C04 BRACE - A4M05263
(x3) 1 7/16"x5 15/16"x27 1/8" (36x151x688)

- INSERT BRACES ONTO ANGLE BRACE BRACKETS.
- REPEAT FOR ALL 3 POST ASSEMBLIES IN THIS STEP.

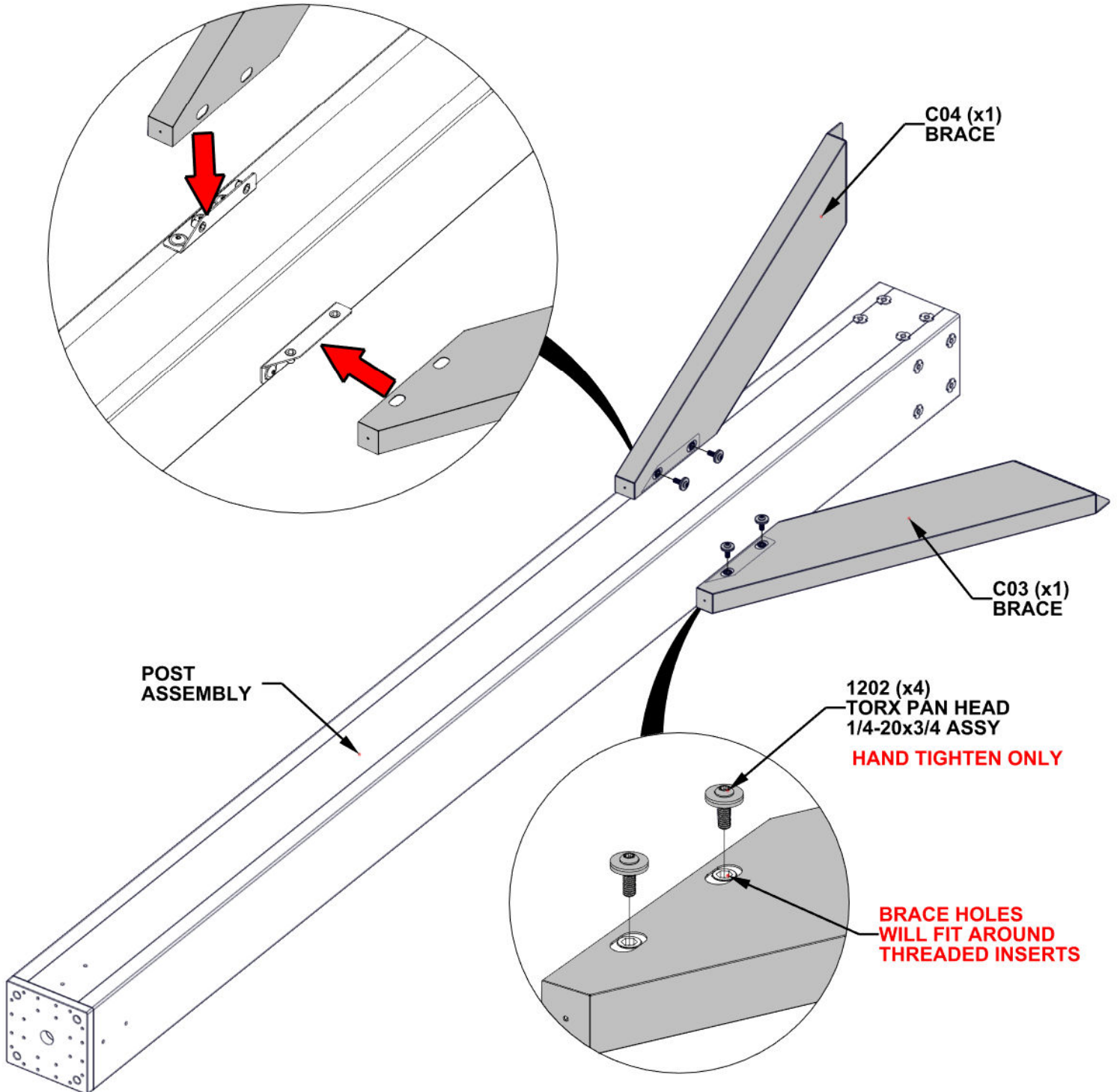

STEP 5 - BEAM ASSEMBLY

Qty	PartNo	Description
10	H101202	TORX PAN HEAD 1/4-20x3/4 ASSY



B05 BEAM - A4M05255
(x2) 1 7/16"X5 1/4"X57 1/8" (36x134x1450.7)



J1 SPLICE BRACKET - A4M02230
(x2) 1 5/16"x5 3/16"x39 3/8" (33.2x131.2x1000)

- BEAM AND SPLICE MUST BE ORIENTED AS SHOWN BELOW.
- SLIDE J1 INTO B05 AND LINE UP THREE HOLES TOP AND BOTTOM.
- REPEAT THIS STEP 2 TIMES.

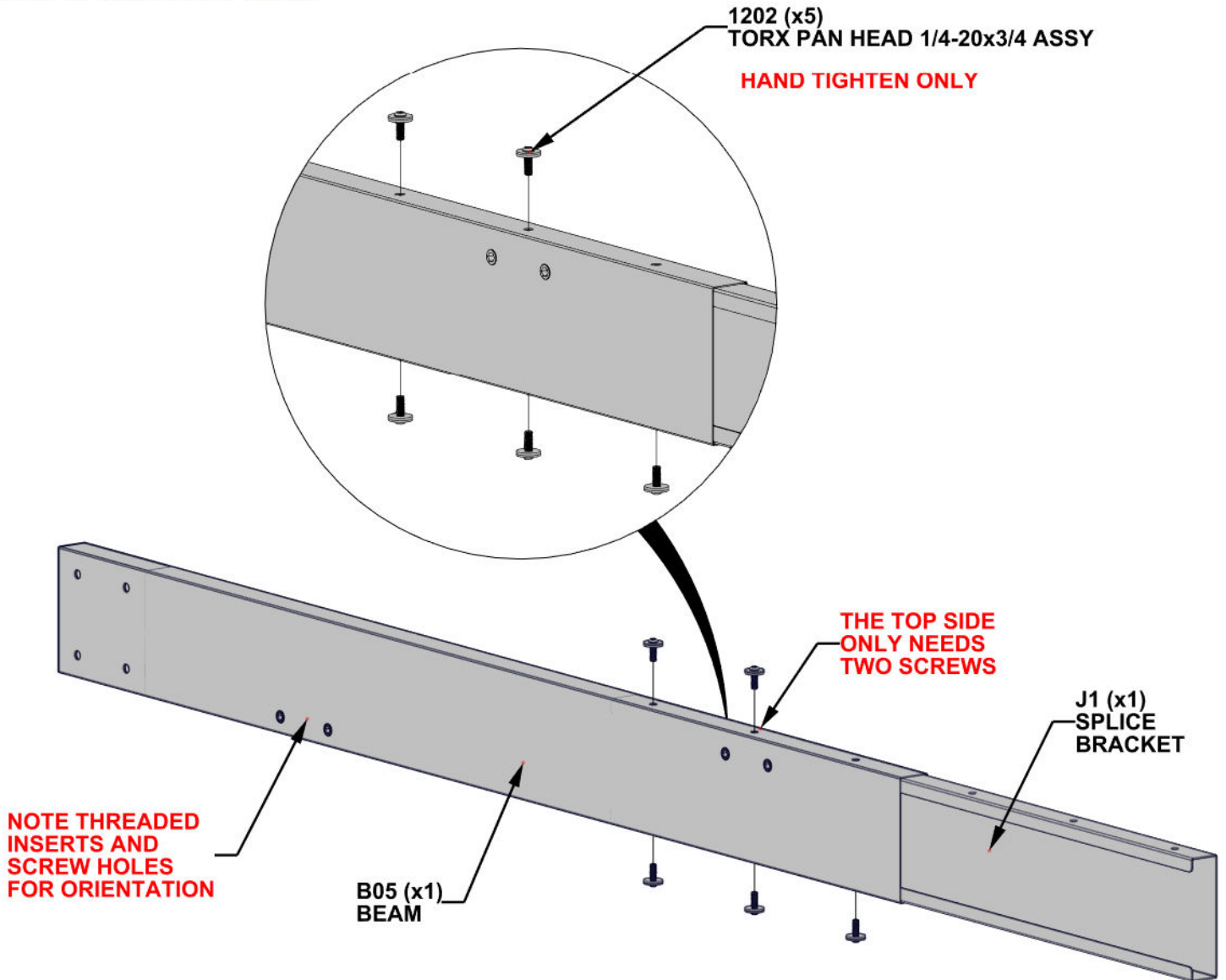

STEP 6 - BEAM ASSEMBLY

Qty	PartNo	Description
10	H101202	TORX PAN HEAD 1/4-20x3/4 ASSY



B04 BEAM - A4M5254
(x2) 1 7/16"X5 1/4"X57 1/8" (36x134x1450.7)

- SLIDE B04 ONTO SPLICE BRACKET.
- GENTLY TAP ENDS OF ASSEMBLY WITH RUBBER Mallet UNTIL GAP CLOSES.
- REPEAT THIS STEP 2 TIMES.

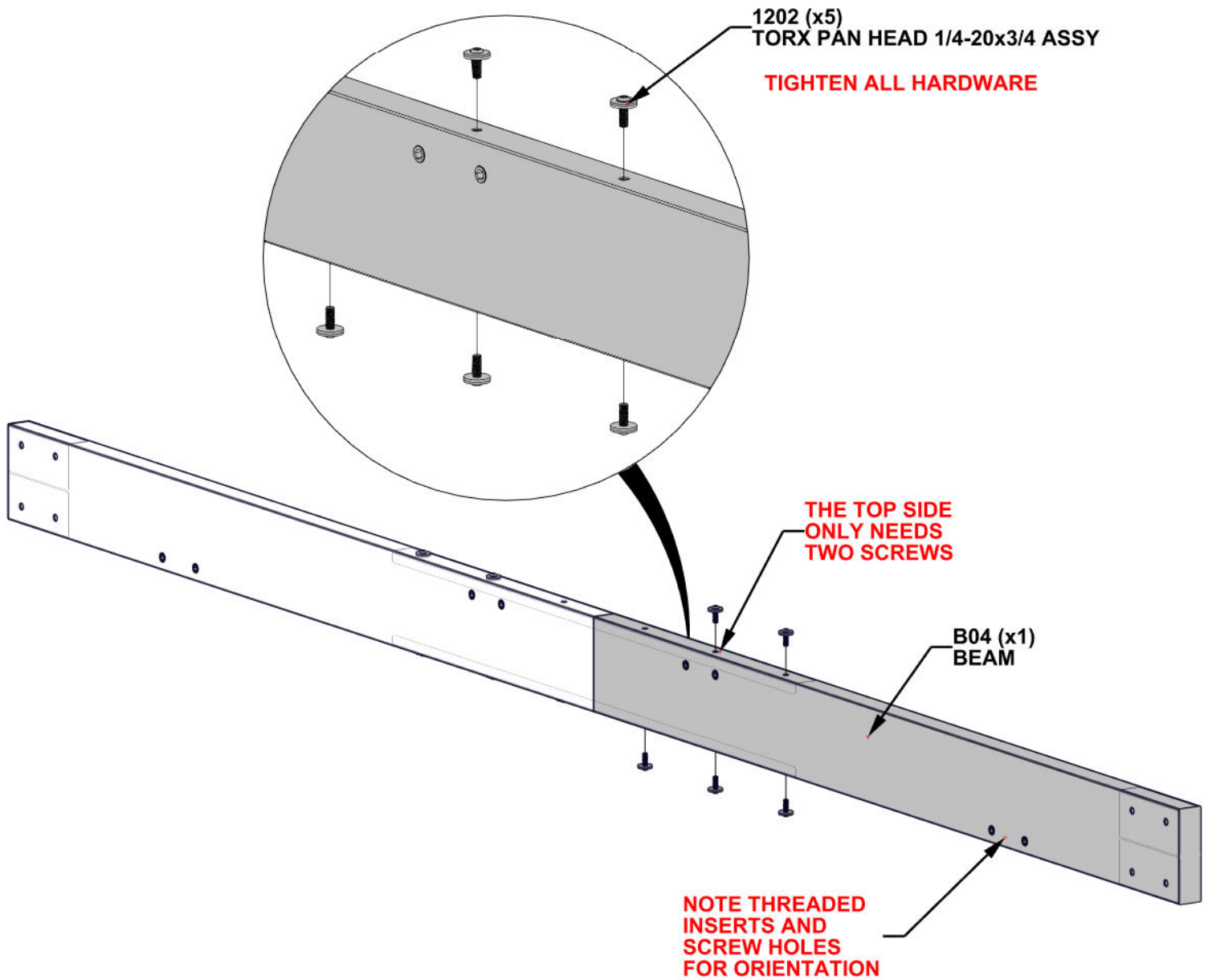

STEP 7 - FRAME ASSEMBLY

Qty	PartNo	Description
4	H100196	BOLT WH 5/16x7 1/4 BLK



BEAM ASSEMBLY FROM STEPS 5-6

- WITH AT LEAST TWO OTHER PEOPLE, ALIGN THRU HOLES IN BEAM ASSEMBLY WITH HOLES IN POSTS.
- ATTACH BEAM ASSEMBLY TO POSTS.

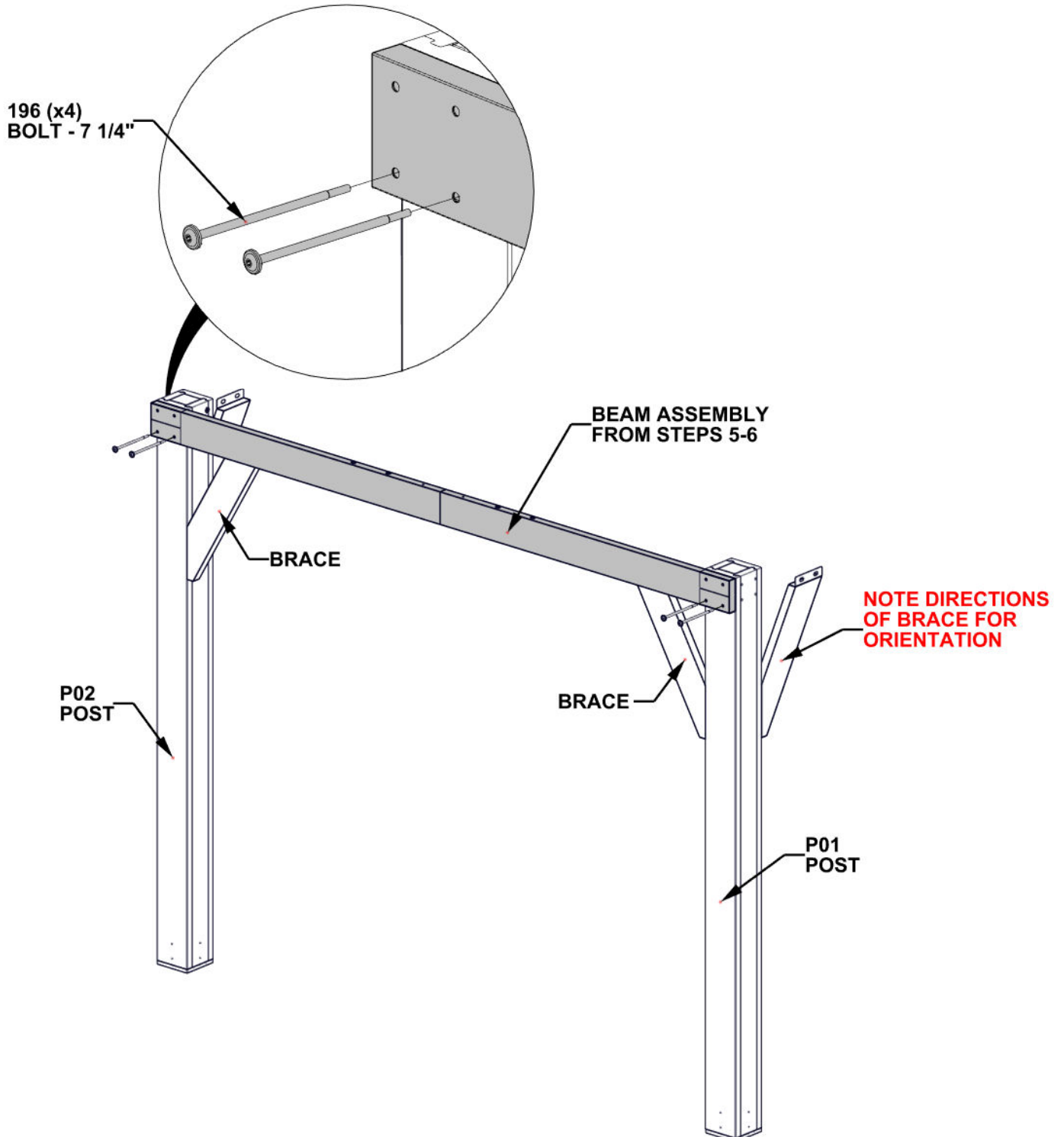

STEP 8 - FRAME ASSEMBLY

Qty	PartNo	Description
4	H101202	TORX PAN HEAD 1/4-20x3/4 ASSY

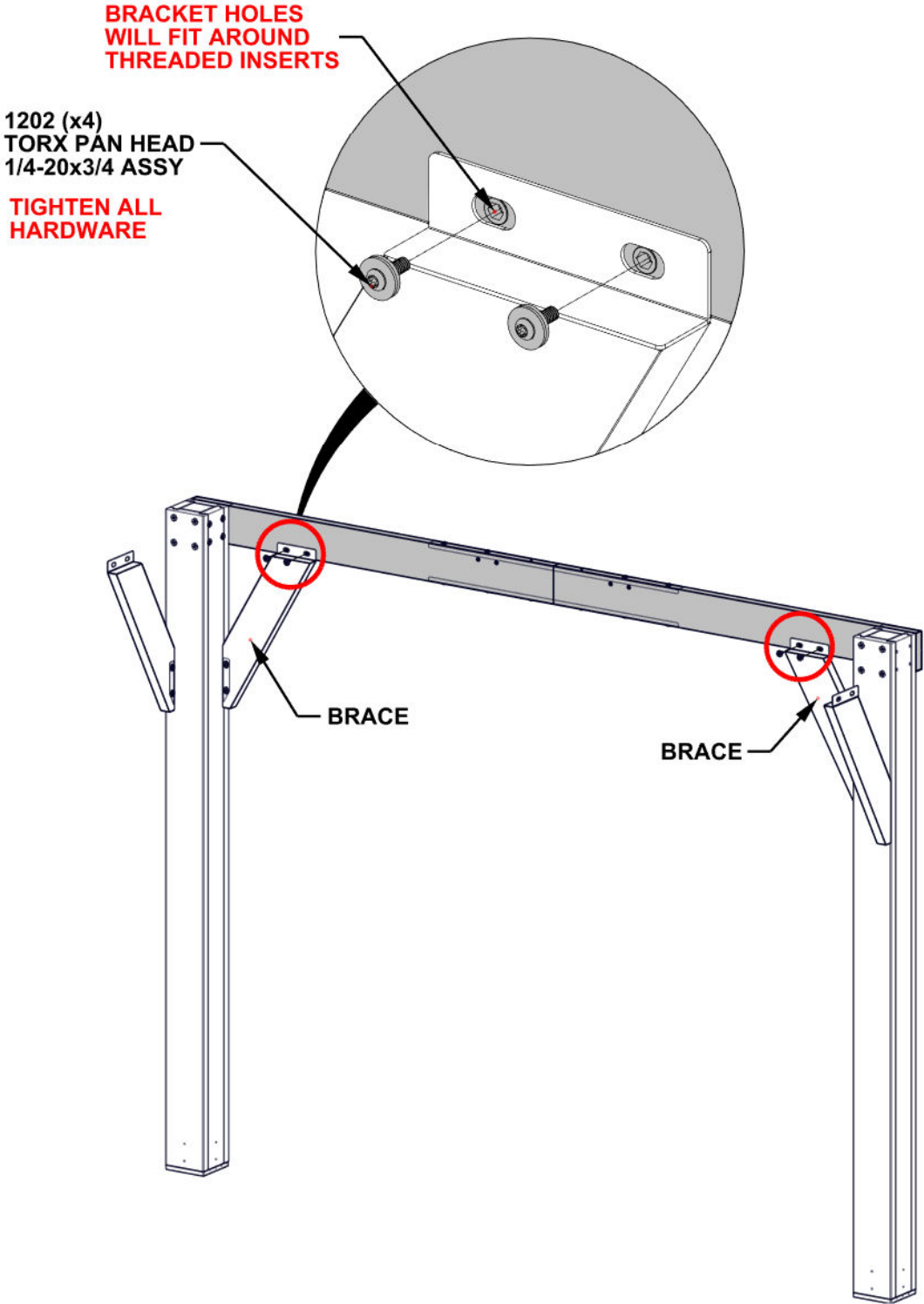

STEP 9 - FRAME ASSEMBLY

Qty	PartNo	Description
4	H100196	BOLT WH 5/16x7 1/4 BLK



BEAM ASSEMBLY FROM STEPS 5-6

- WITH AT LEAST TWO OTHER PEOPLE, ALIGN THRU HOLES IN BEAM ASSEMBLY WITH HOLES IN POSTS.
- ATTACH BEAM ASSEMBLY TO POSTS.

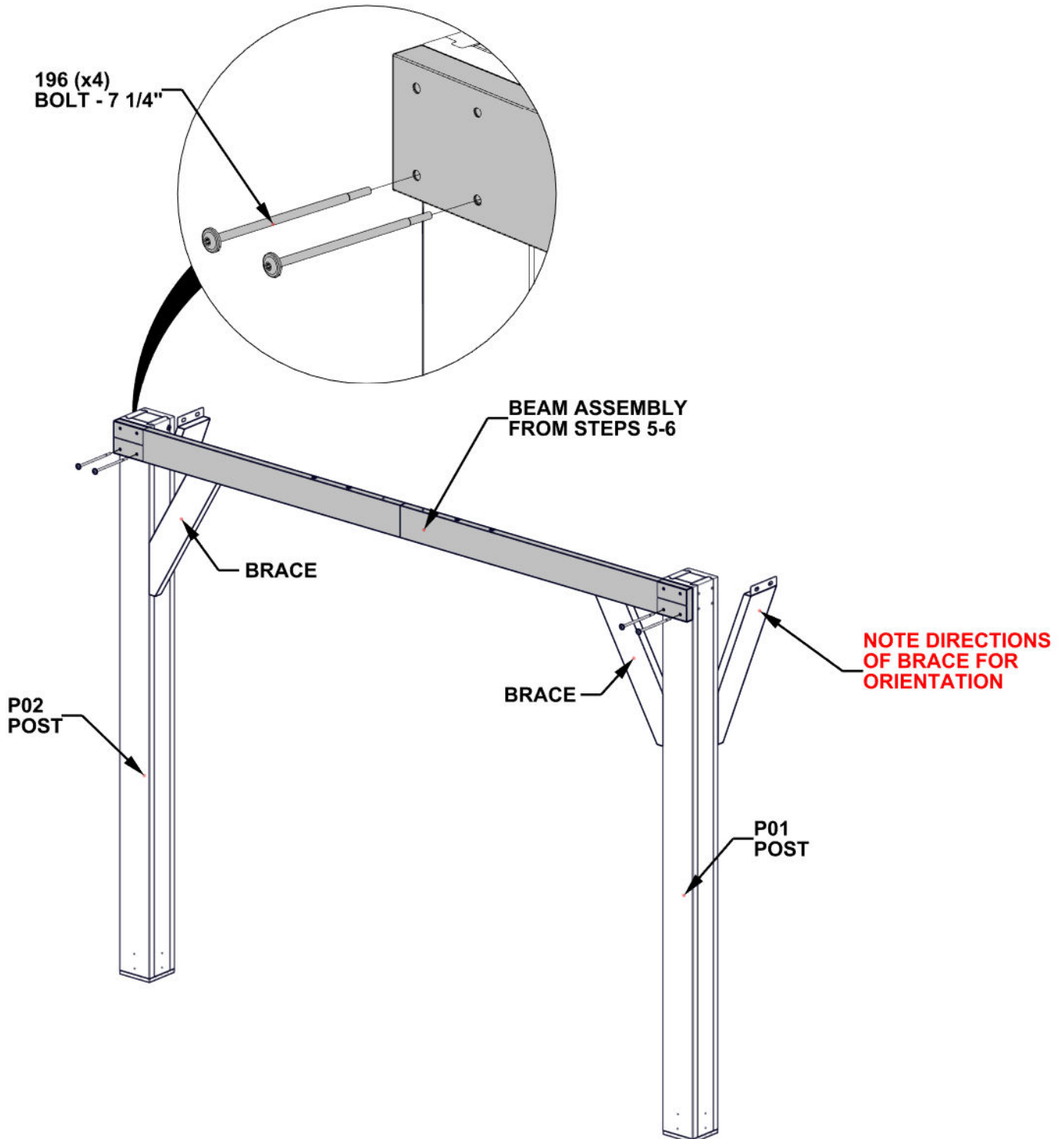

STEP 10 - FRAME ASSEMBLY

Qty	PartNo	Description
4	H101202	TORX PAN HEAD 1/4-20x3/4 ASSY

**BRACKET HOLES
WILL FIT AROUND
THREADED INSERTS**

**1202 (x4)
TORX PAN HEAD
1/4-20x3/4 ASSY**

**TIGHTEN ALL
HARDWARE**

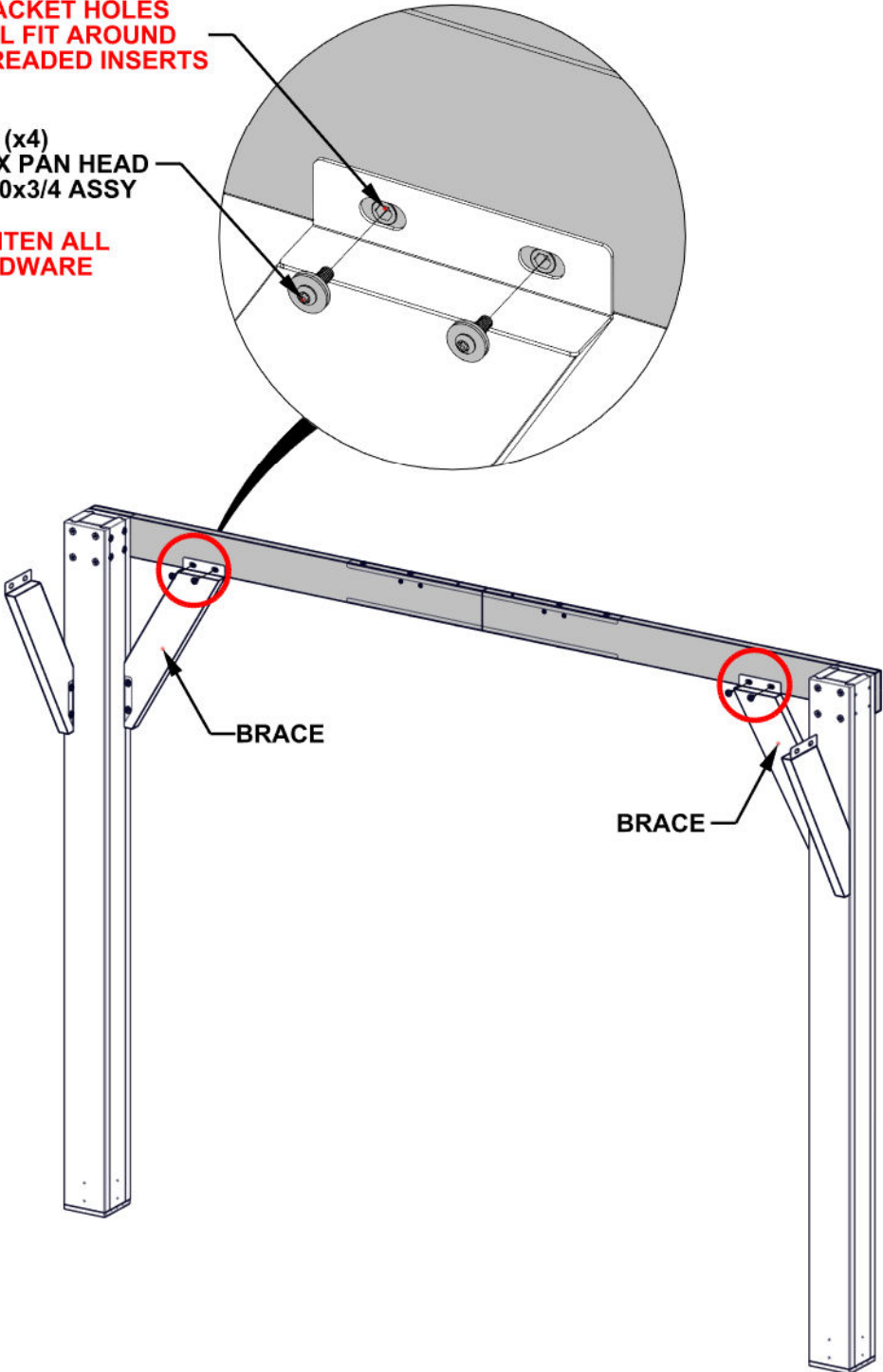

STEP 11 - BEAM ASSEMBLY

Qty	PartNo	Description
6	H101202	TORX PAN HEAD 1/4-20x3/4 ASSY



B01 BEAM - A4M05251
(x1) 1 7/16"X5 1/4"X55 5/8" (36x134x1412.53)



J1 SPLICE BRACKET - A4M02230
(x1) 1 5/16"x5 3/16"x39 3/8" (33.2x131.2x1000)

- BEAM AND SPLICE MUST BE ORIENTED AS SHOWN BELOW.
- SLIDE J1 INTO B01 AND LINE UP THREE HOLES TOP AND BOTTOM.

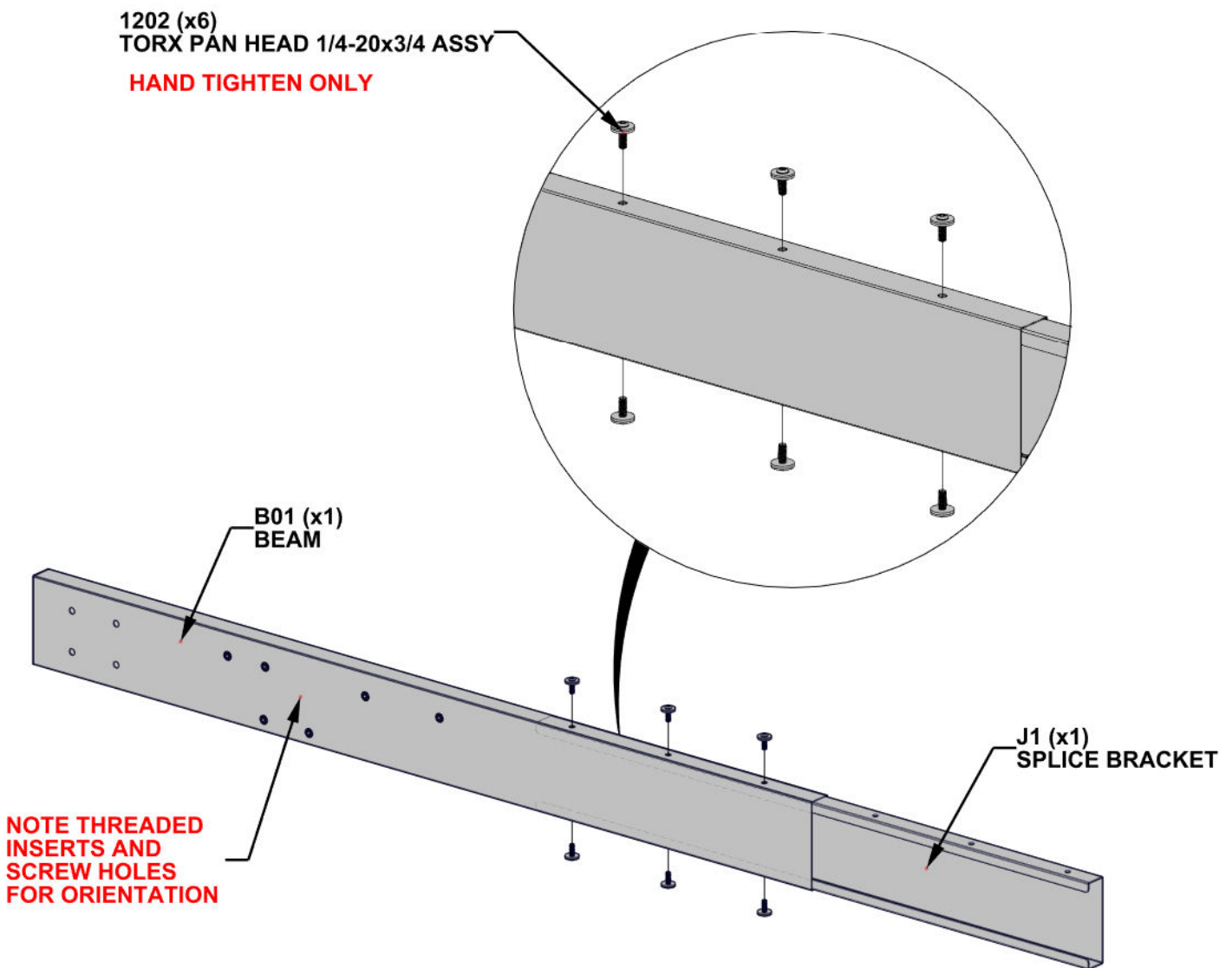

STEP 12 - BEAM ASSEMBLY

Qty	PartNo	Description
6	H101202	TORX PAN HEAD 1/4-20x3/4 ASSY



B03 BEAM - A4M05253
(x1) 1 7/16"X5 1/4"X55 9/16" (36x134x1411.33)

- SLIDE B03 ONTO SPLICE BRACKET.
- GENTLY TAP ENDS OF ASSEMBLY WITH RUBBER Mallet UNTIL GAP CLOSES.

1202 (x6)
TORX PAN HEAD 1/4-20x3/4 ASSY

TIGHTEN ALL HARDWARE

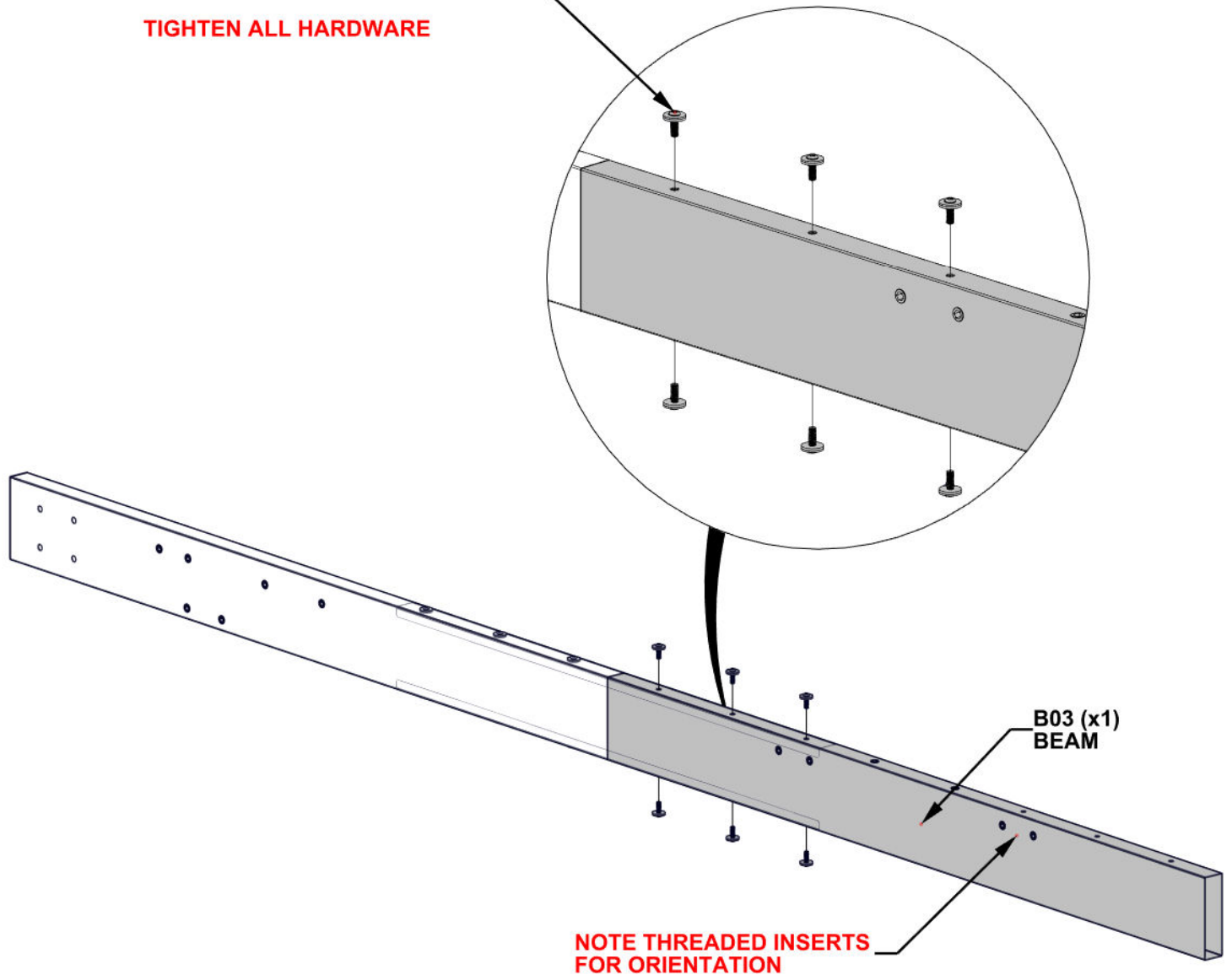

STEP 13 - BEAM ASSEMBLY

Qty	PartNo	Description
6	H101202	TORX PAN HEAD 1/4-20x3/4 ASSY



J1 SPLICE BRACKET - A4M02230
(x1) 1 5/16"x5 3/16"x39 3/8" (33.2x131.2x1000)

- BEAM AND SPLICE MUST BE ORIENTED AS SHOWN BELOW.
- SLIDE J1 INTO B03 AND LINE UP THREE HOLES TOP AND BOTTOM.

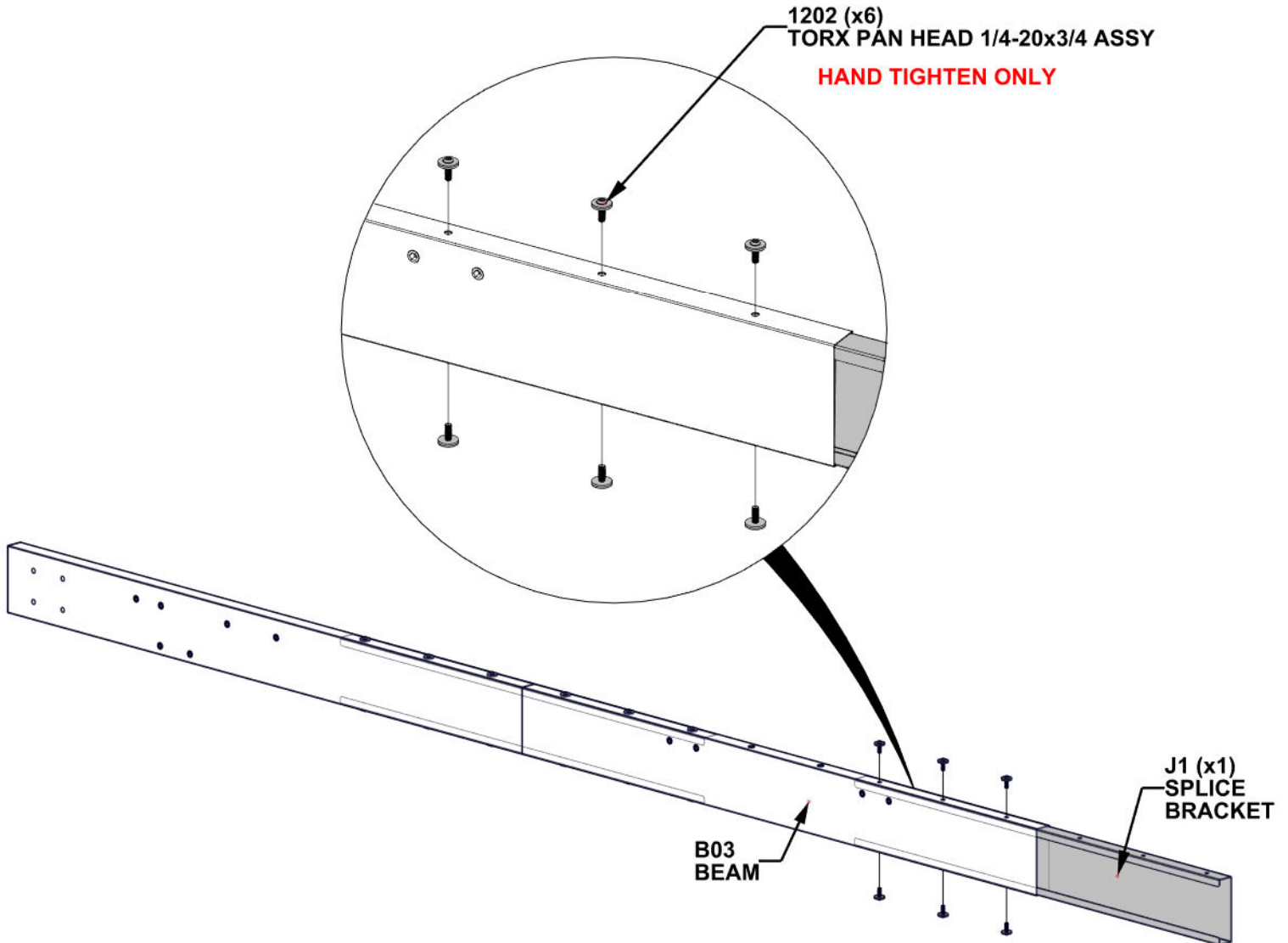

STEP 14 - BEAM ASSEMBLY

Qty	PartNo	Description
6	H101202	TORX PAN HEAD 1/4-20x3/4 ASSY



B02 BEAM - A4M05252
(x1) 1 7/16"X5 1/4"X55 5/8" (36x134x1412.53)

- SLIDE B02 ONTO SPLICE BRACKET.
- GENTLY TAP ENDS OF ASSEMBLY WITH RUBBER Mallet UNTIL GAP CLOSES.

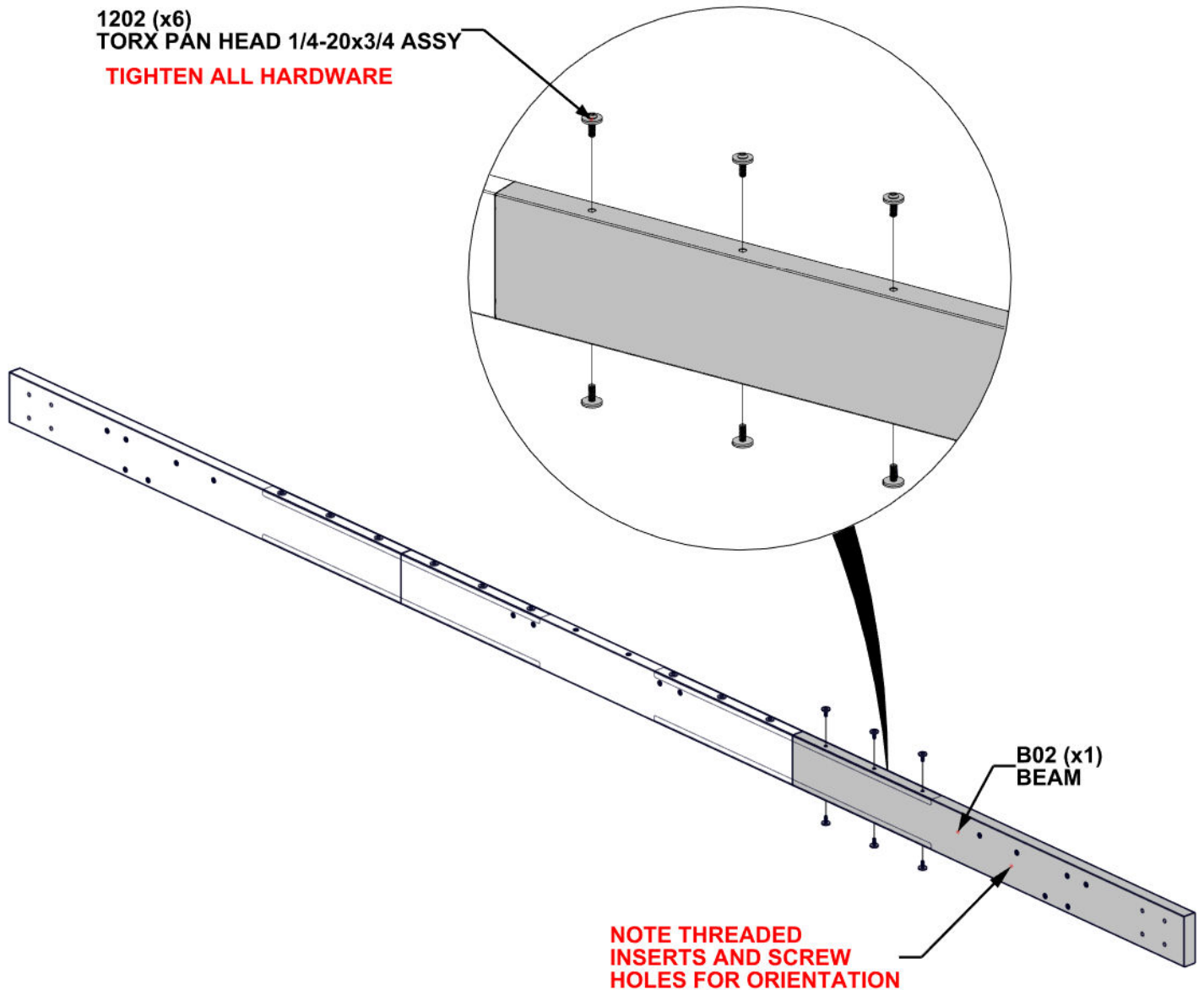

STEP 15 - BEAM ASSEMBLY

Qty	PartNo	Description
4	H101202	TORX PAN HEAD 1/4-20x3/4 ASSY

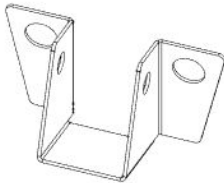

A4M05267 RAFTER BRACKET
(x2)

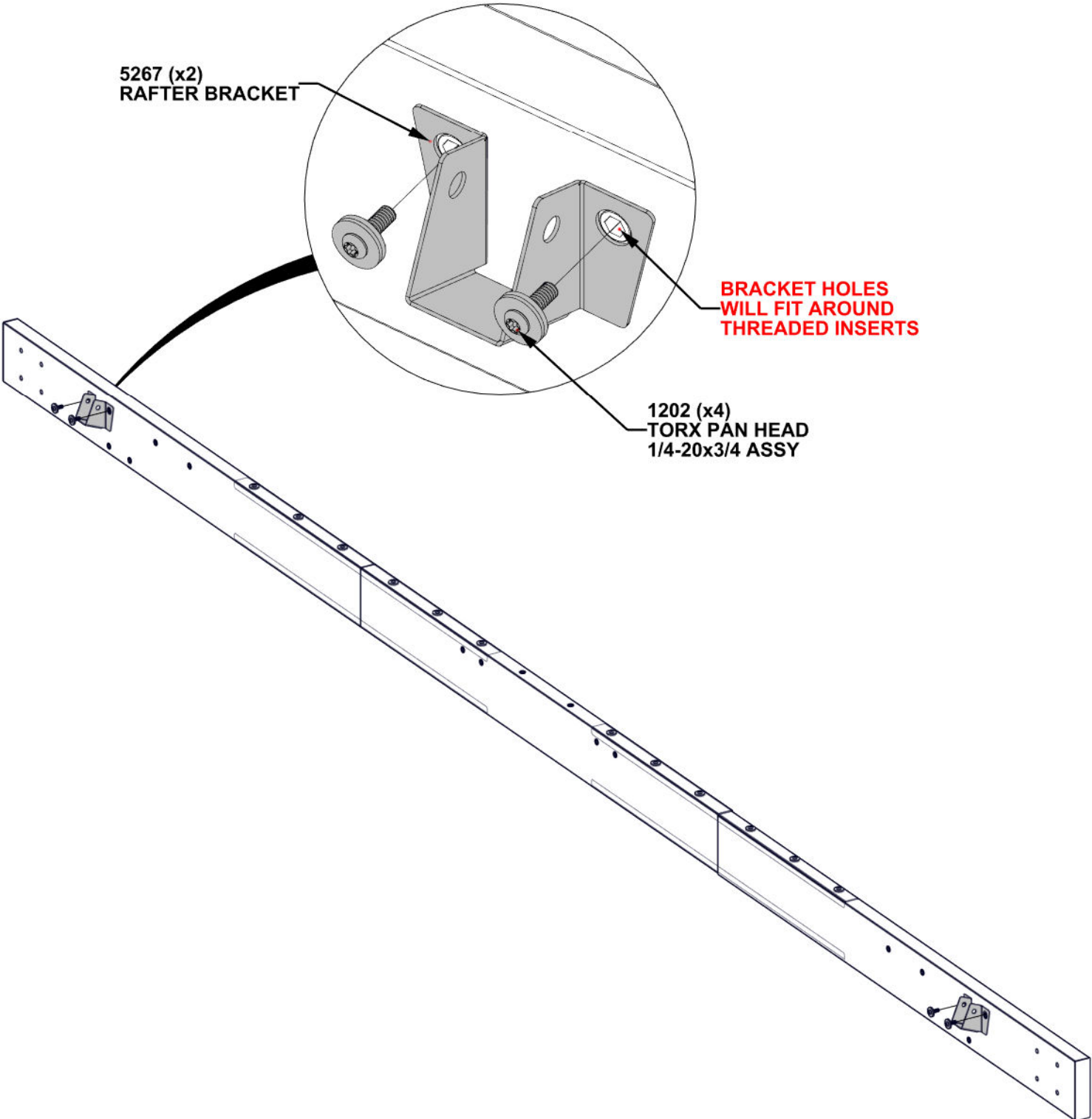

STEP 16 - BEAM ASSEMBLY

Qty	PartNo	Description
4	H100198	WASHER LOCK EXT BLK
4	H100457	BOLT WH 5/16x2 BLK



D02 FASCIA BOARD - W4L21707
 (x2) 1 7/16"x4 3/4"x20 1/2" (36x120x522)

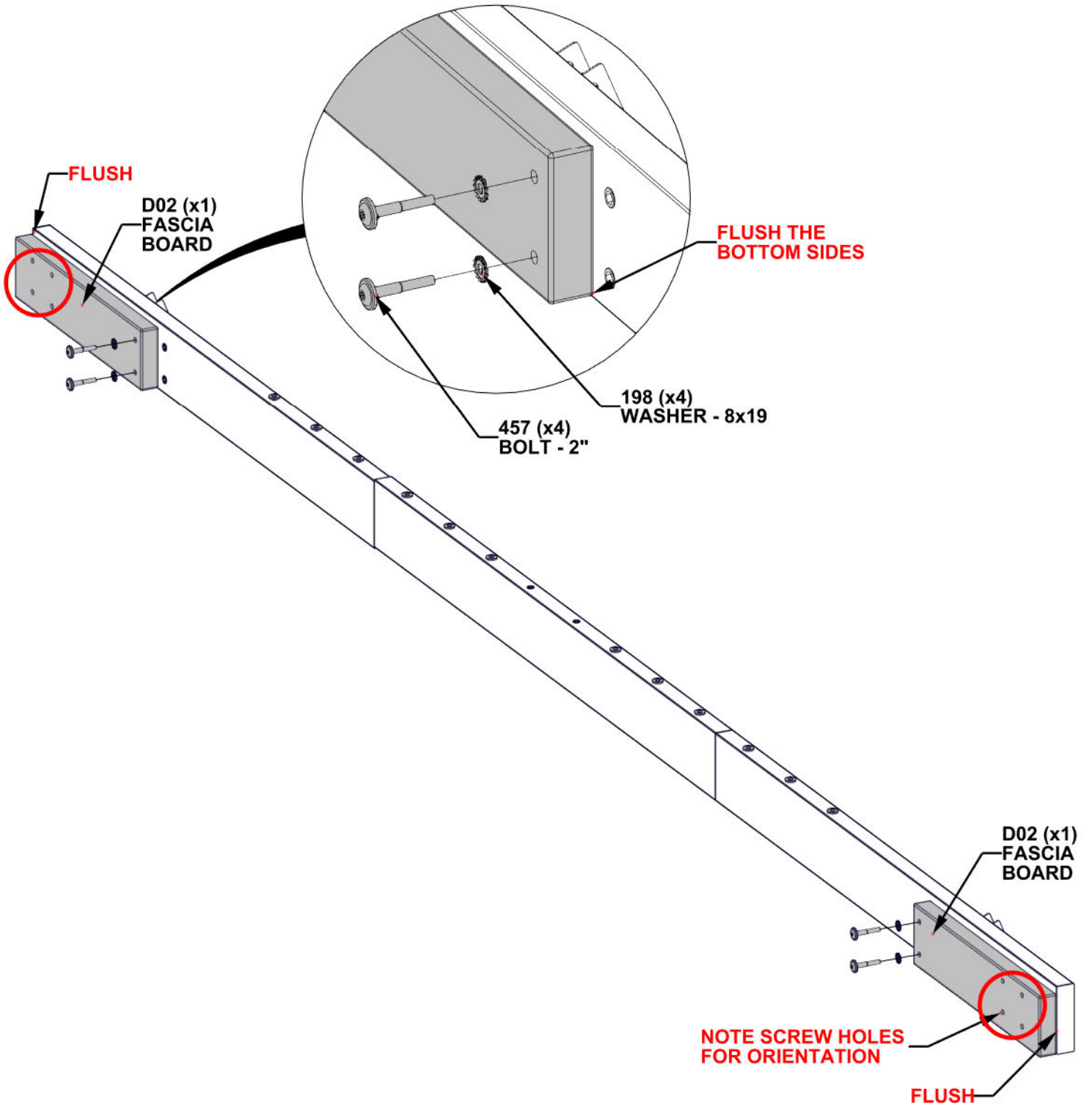

**REPEAT BEAM ASSEMBLY
STEPS 11 THROUGH 16**

STEP 17A - FRAME ASSEMBLY

Qty	PartNo	Description
8	H100198	WASHER LOCK EXT BLK
8	H101058	BOLT WH 5/16x8 3/4 BLK



BEAM ASSEMBLY FROM STEPS 11-16

- WITH AT LEAST TWO OTHER PEOPLE, ALIGN THRU HOLES IN BEAM ASSEMBLY WITH HOLES IN POSTS.
- ATTACH BEAM ASSEMBLY TO POSTS.

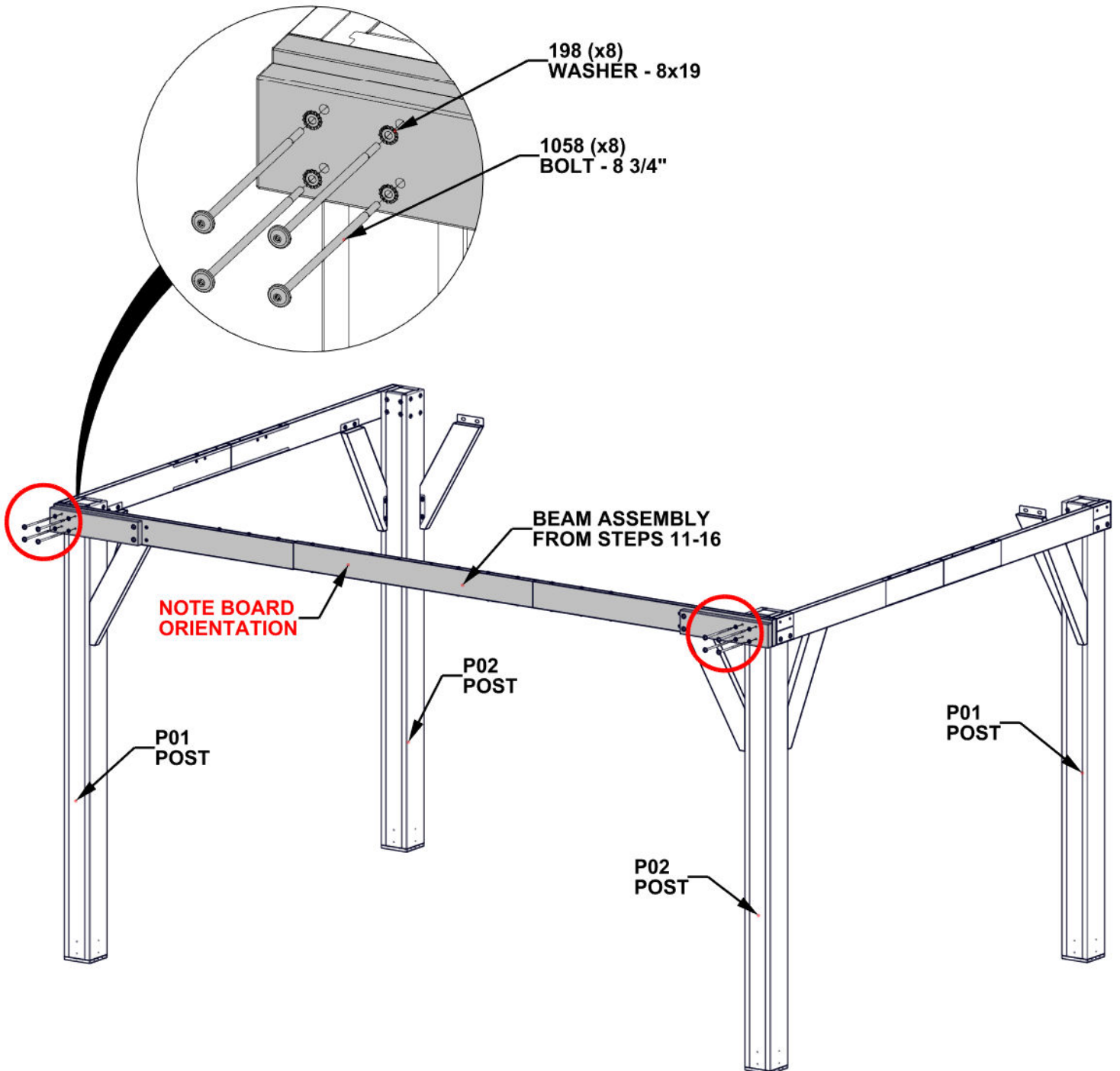

STEP 17B - FRAME ASSEMBLY

Qty	PartNo	Description
4	H101202	TORX PAN HEAD 1/4-20x3/4 ASSY

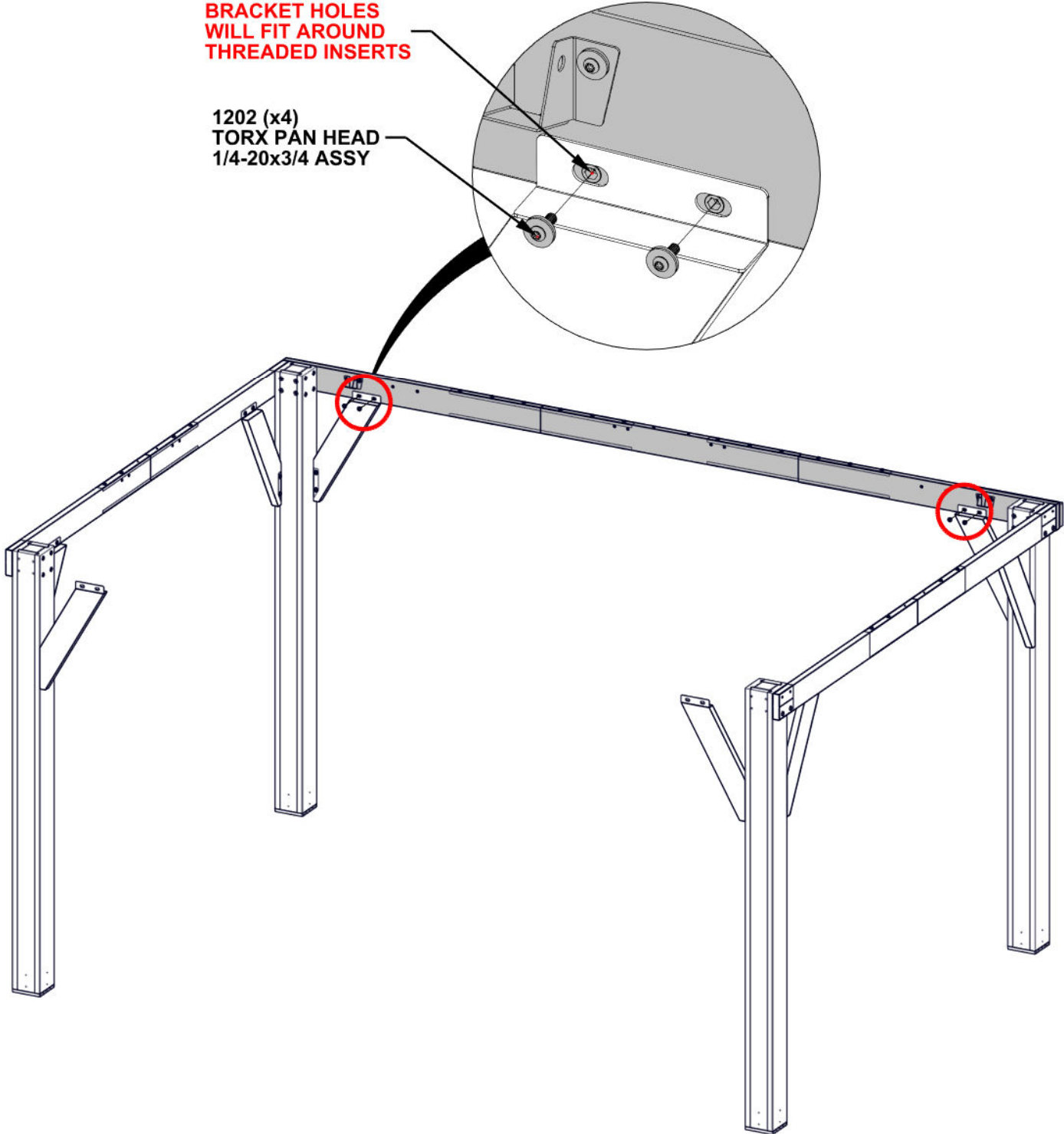

STEP 18A - FRAME ASSEMBLY

Qty	PartNo	Description
8	H100198	WASHER LOCK EXT BLK
8	H101058	BOLT WH 5/16x8 3/4 BLK



BEAM ASSEMBLY FROM STEPS 11-16

- WITH AT LEAST TWO OTHER PEOPLE, ALIGN THRU HOLES IN BEAM ASSEMBLY WITH HOLES IN POSTS.
- ATTACH BEAM ASSEMBLY TO POSTS.

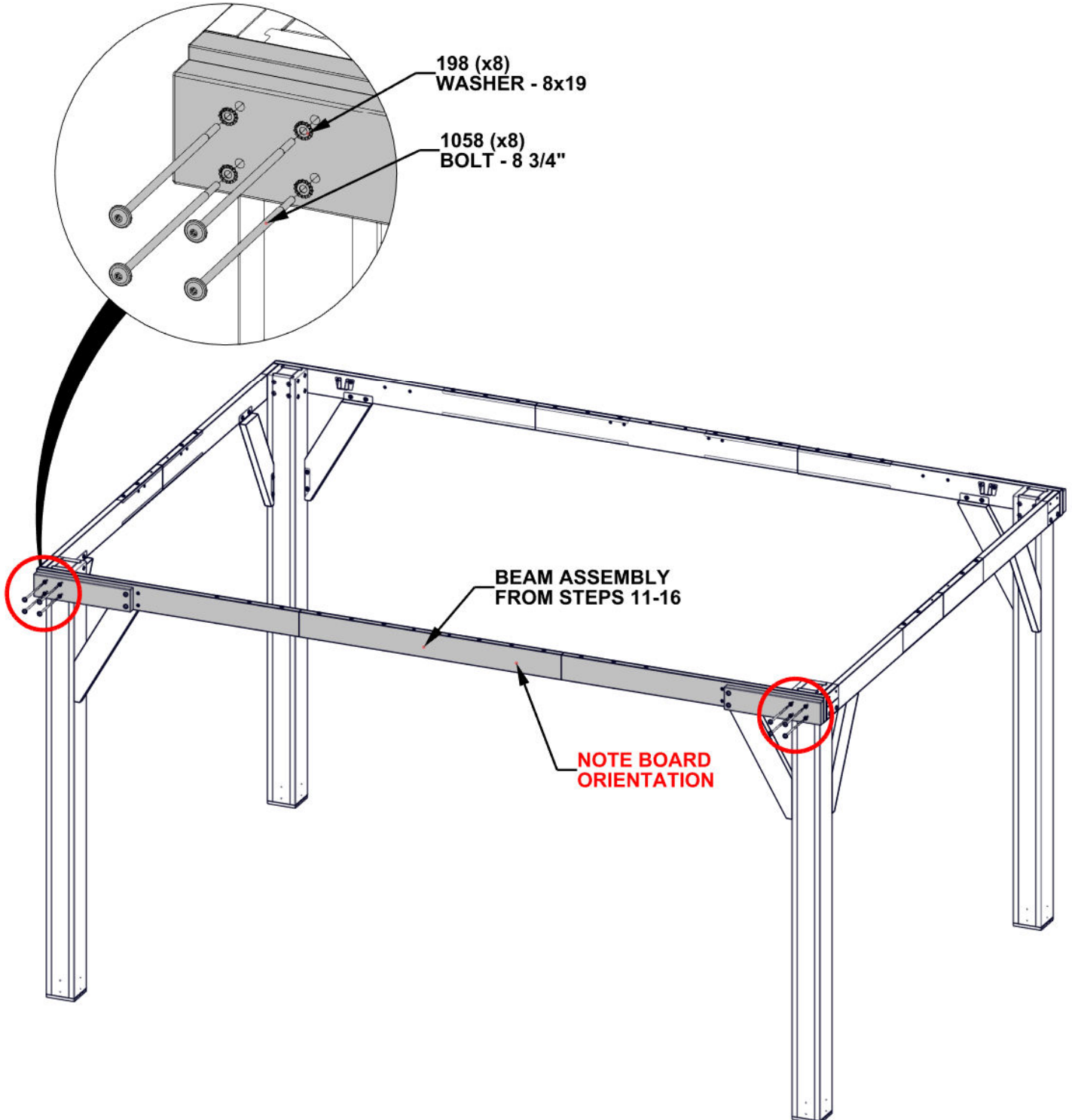

STEP 18B - FRAME ASSEMBLY

Qty	PartNo	Description
4	H101202	TORX PAN HEAD 1/4-20x3/4 ASSY

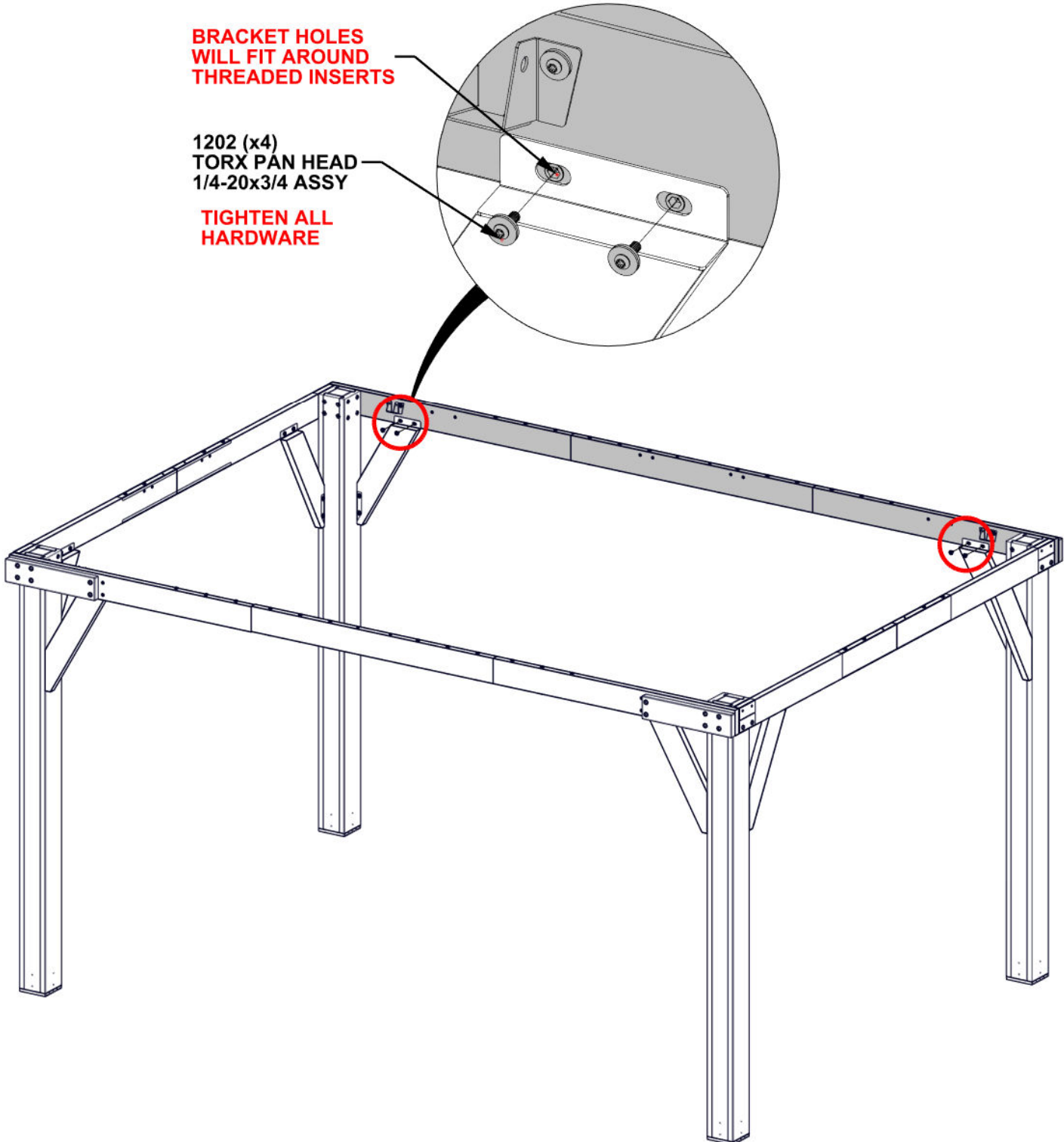

STEP 19 - SQUARE STRUCTURE

- CRITICAL:**
- SQUARE UNIT BEFORE PROCEEDING TO NEXT STEPS.
 - THE BELOW DIMENSIONS ARE CRITICAL TO THE FINAL ASSEMBLY.
 - MEASUREMENTS SHOULD BE WITHIN +/- 1/4" (6mm).
 - MEASUREMENTS OUTSIDE OF TOLERANCE WILL LEAD TO ISSUES ON FUTURE ASSEMBLY STEPS.
 - TIGHTEN ALL HARDWARE FROM PREVIOUS STEPS.

MEASUREMENTS TAKEN FROM INSIDE CORNER TO INSIDE CORNER OF POST

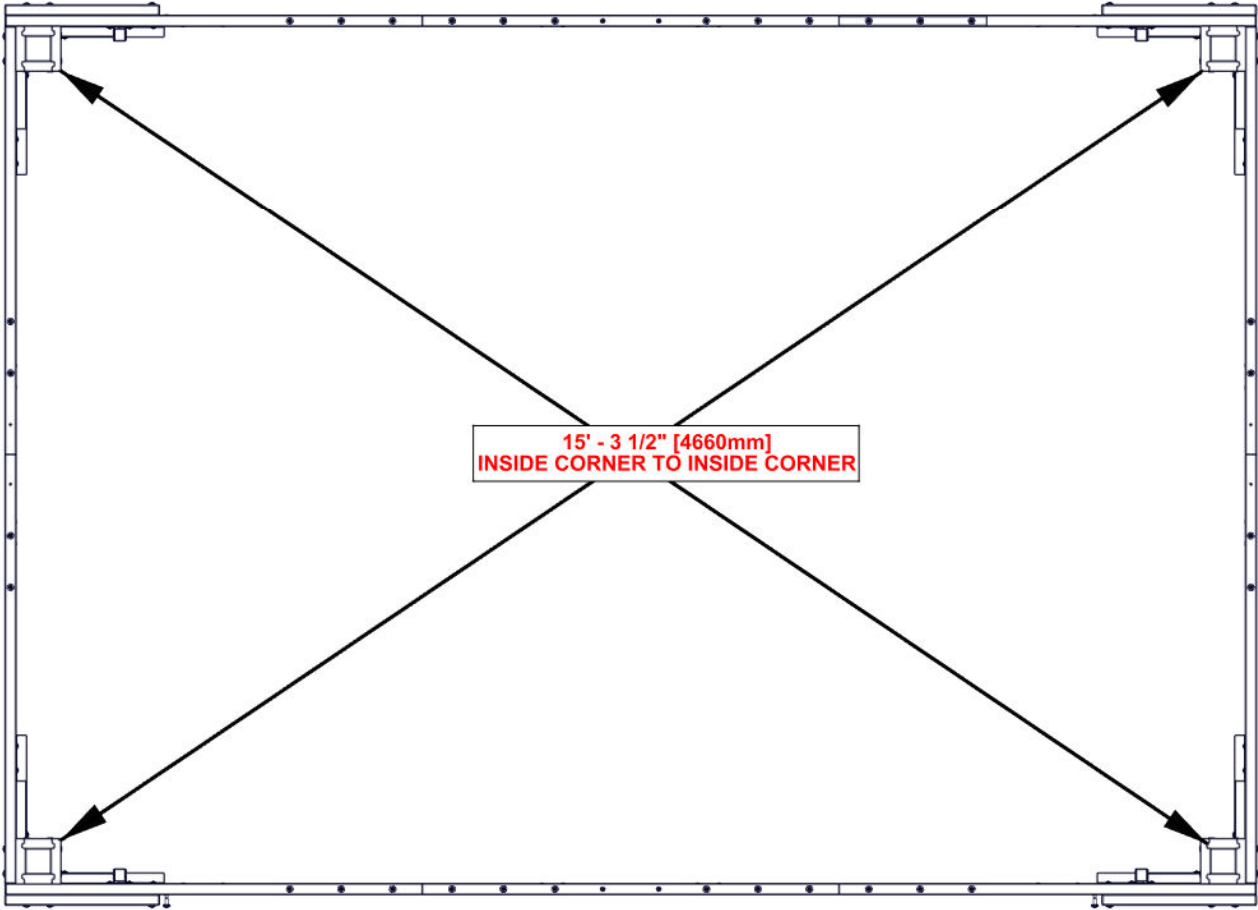

STEP 20 - ROOF ASSEMBLY

Qty	PartNo	Description
2	H101202	TORX PAN HEAD 1/4-20x3/4 ASSY



B06 VERTICAL GABLE SUPPORT - A4M05258
(x1) 1 7/16"X9 1/16"X22 3/16" (36x230x563.78)

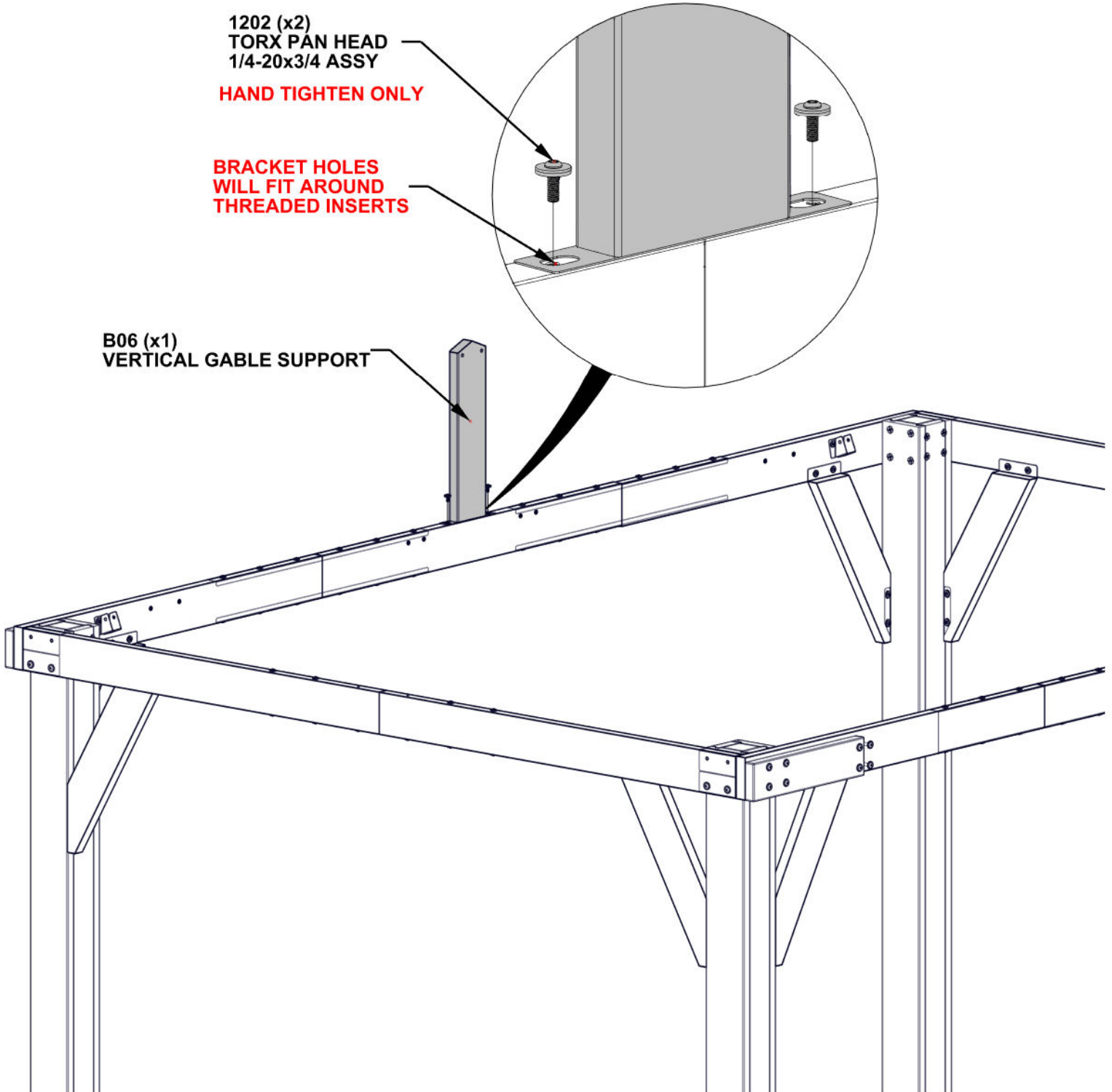

1202 (x2)
TORX PAN HEAD
1/4-20x3/4 ASSY

HAND TIGHTEN ONLY

BRACKET HOLES
WILL FIT AROUND
THREADED INSERTS

B06 (x1)
VERTICAL GABLE SUPPORT

STEP 21 - ROOF ASSEMBLY

Qty	PartNo	Description
4	H101202	TORX PAN HEAD 1/4-20x3/4 ASSY

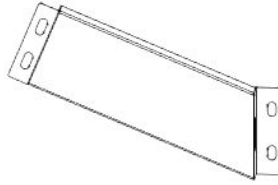
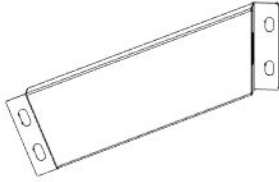

B07 GABLE SUPPORT - A4M05264
(x1) 1 7/16"X5 7/8"X18 1/2" (37x149x470)

B08 GABLE SUPPORT - A4M05265
(x1) 1 7/16"X5 7/8"X18 1/2" (37x149x470)

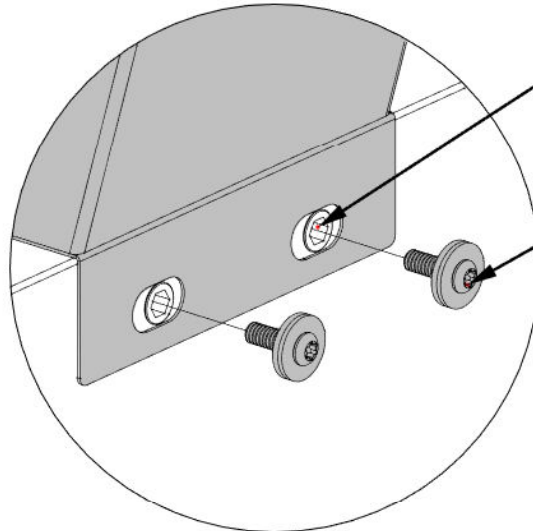

**BRACKET HOLES
WILL FIT AROUND
THREADED INSERTS**

**1202 (x4)
TORX PAN HEAD
1/4-20x3/4 ASSY**

HAND TIGHTEN ONLY

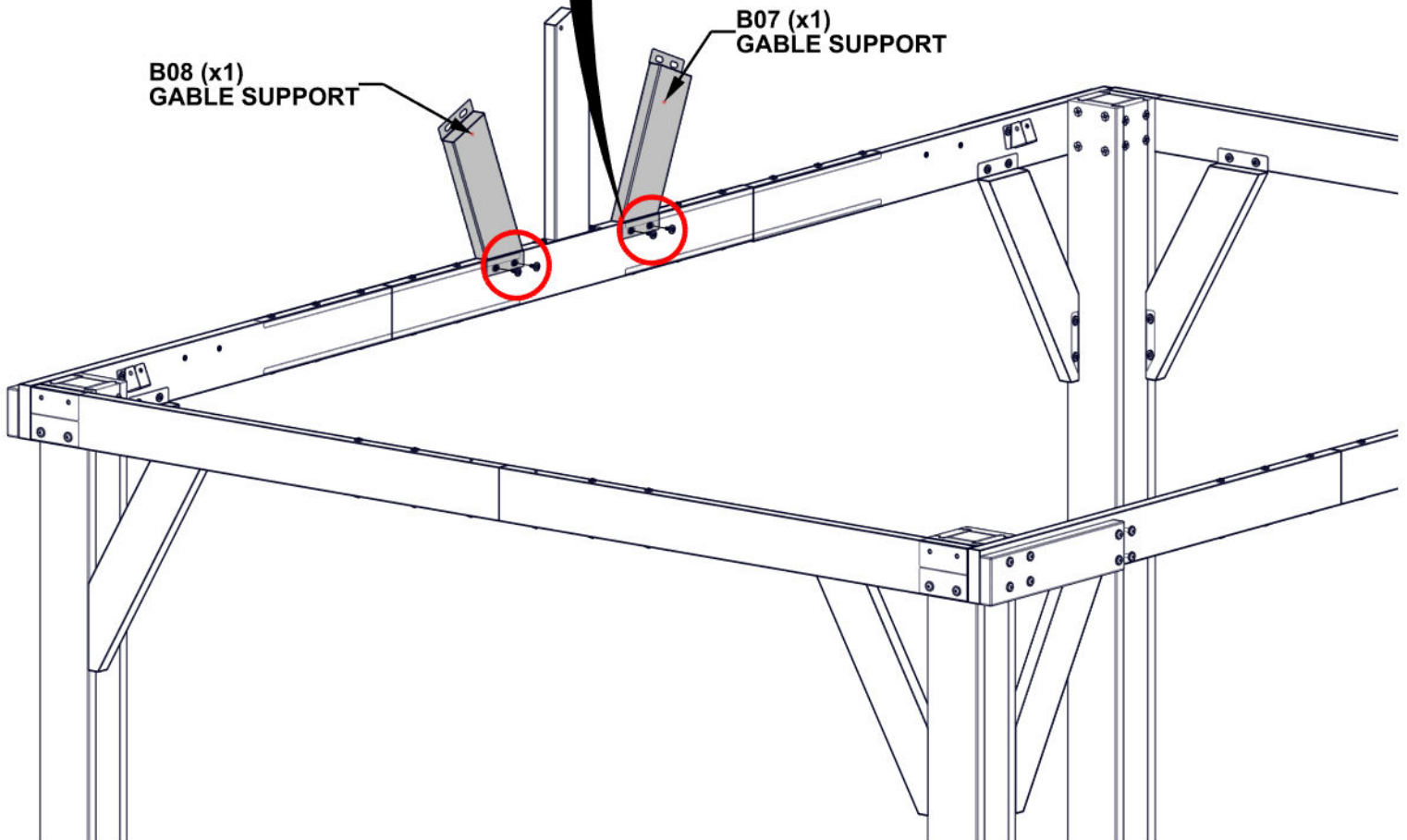

STEP 22 - GABLE ASSEMBLY

Qty	PartNo	Description
2	H100379	T-NUT 5/16 BLK
2	H100407	BOLT WH 5/16x1 1/2 BLK
4	H100821	SCREW PFH 8x2 3/4 BLK



D03 GABLE BOARD - W4L21708
 (x1) 1 7/16"x5 1/4"x70 1/4" (36x134x1775)



P03 CLEAT - W4L22266
 (x1) 1 7/16"x1 7/16"x57 1/8" (36x36x1450)

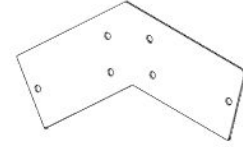

A4M05859 GABLE BRACKET
 (x1)

- **INSERT T-NUTS FIRST**
- **ALIGN PILOT HOLES IN CLEAT AND GABLE BOARD.**
- **FOR EASE OF ASSEMBLY, WE RECOMMEND USING SAW HORSES FOR THIS STEP.**

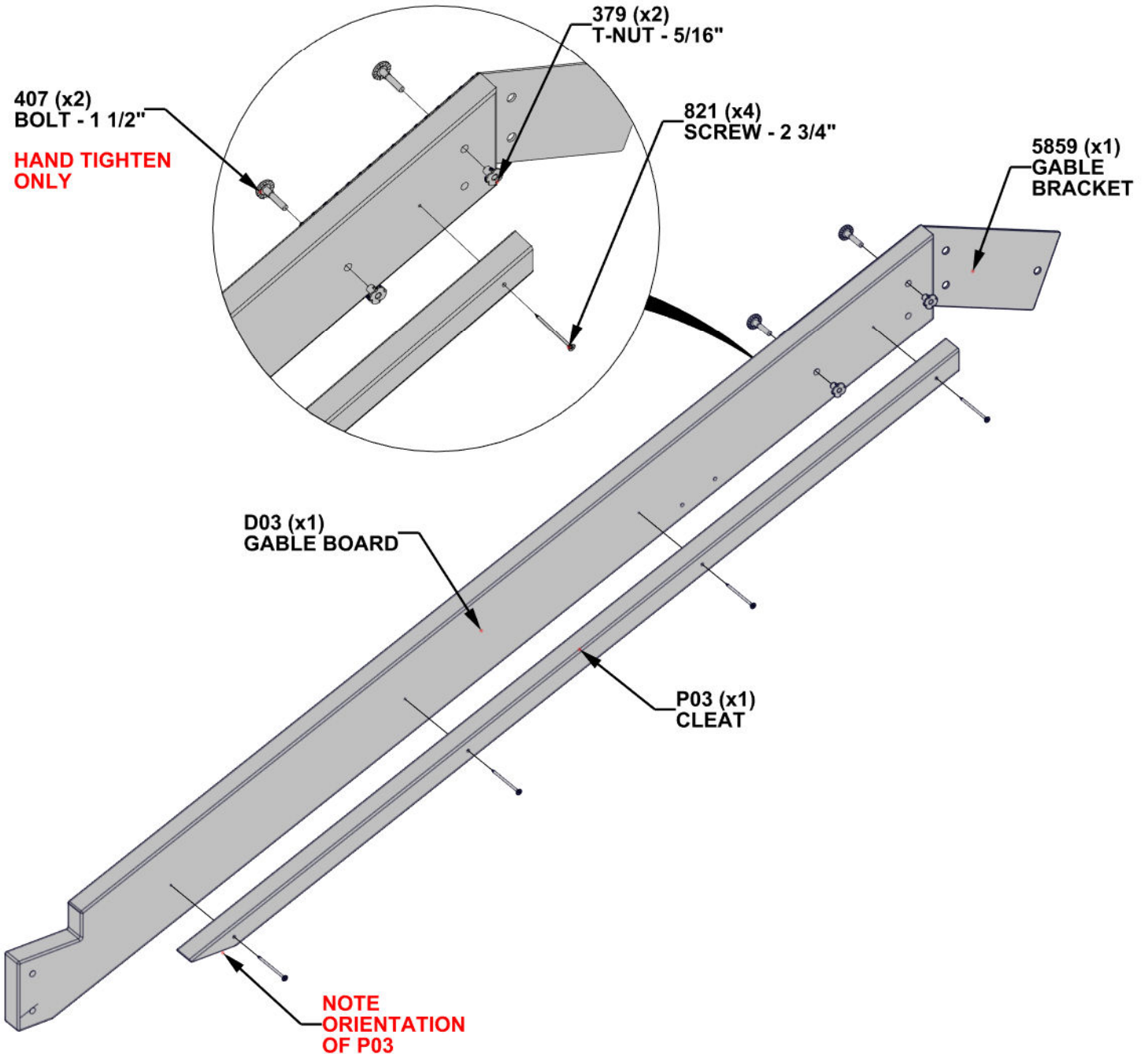

STEP 23 - ROOF ASSEMBLY

Qty	PartNo	Description
2	H100198	WASHER LOCK EXT BLK
2	H100457	BOLT WH 5/16x2 BLK
2	H100854	LAG SCREW WH 5/16x1 BLK

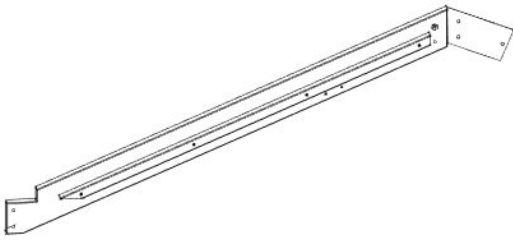

GABLE ASSEMBLY FROM STEP 22

- ALIGN SCREWS WITH PILOT HOLES IN GABLE ASSEMBLY.

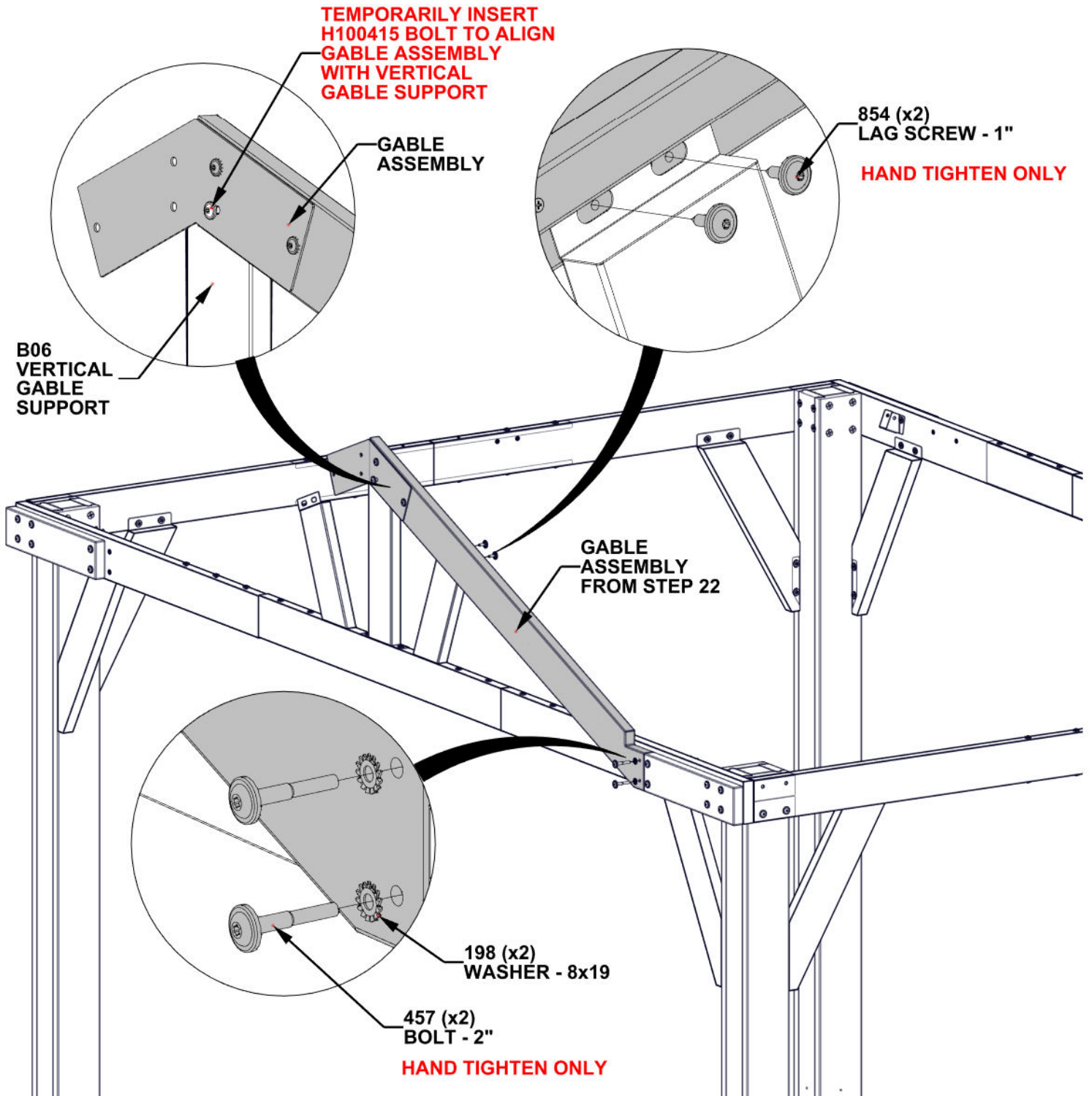

STEP 24 - GABLE ASSEMBLY

Qty	PartNo	Description
2	H100379	T-NUT 5/16 BLK
4	H100821	SCREW PFH 8x2 3/4 BLK



D04 GABLE BOARD - W4L22267
 (x1) 1 7/16"x5 1/4"x70 1/4" (36x134x1775)



P03 CLEAT - W4L22266
 (x1) 1 7/16"x1 7/16"x57 1/8" (36x36x1450)

- **INSERT T-NUTS FIRST**
- **ALIGN PILOT HOLES IN CLEAT AND GABLE BOARD.**
- **FOR EASE OF ASSEMBLY, WE RECOMMEND USING SAW HORSES FOR THIS STEP.**

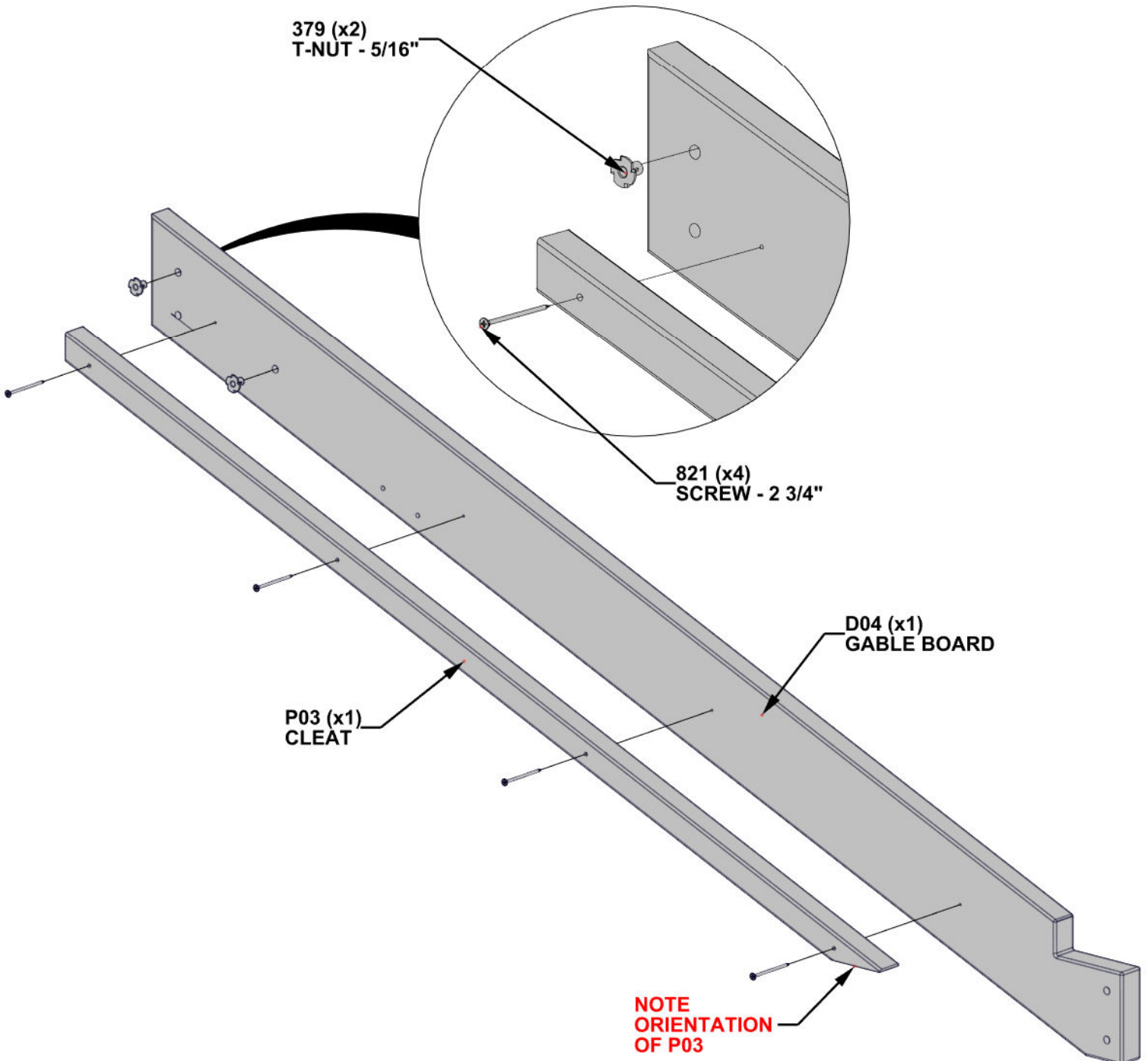

STEP 25 - ROOF ASSEMBLY

Qty	PartNo	Description
2	H100198	WASHER LOCK EXT BLK
2	H100407	BOLT WH 5/16x1 1/2 BLK
2	H100457	BOLT WH 5/16x2 BLK
2	H100854	LAG SCREW WH 5/16x1 BLK

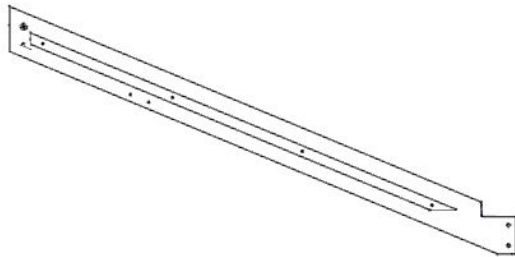

GABLE ASSEMBLY FROM STEP 24

- ALIGN SCREWS WITH PILOT HOLES IN GABLE ASSEMBLY.
- **TIGHTEN ALL HARDWARE.**

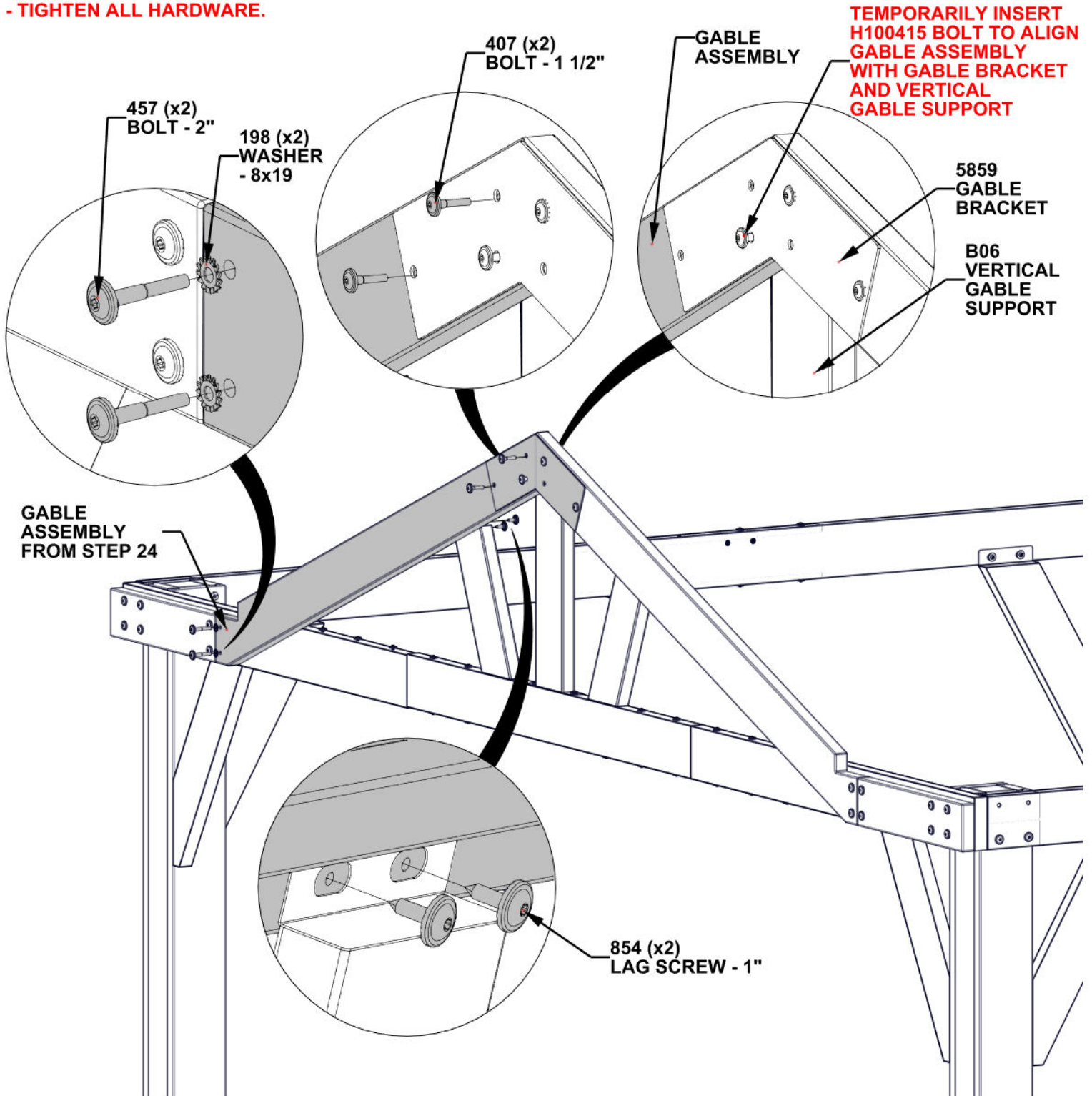

**REPEAT ROOF ASSEMBLY STEPS 20 - 25
TO INSTALL GABLE ON OPPOSITE SIDE**

STEP 26 - ROOF ASSEMBLY

Qty	PartNo	Description
2	H101202	TORX PAN HEAD 1/4-20x3/4 ASSY



B06 VERTICAL GABLE SUPPORT - A4M05258
(x1) 1 7/16"X9 1/16"X22 3/16" (36x230x563.78)

1202 (x2)
TORX PAN HEAD
1/4-20x3/4 ASSY

HAND TIGHTEN ONLY

**BRACKET HOLES
WILL FIT AROUND
THREADED INSERTS**

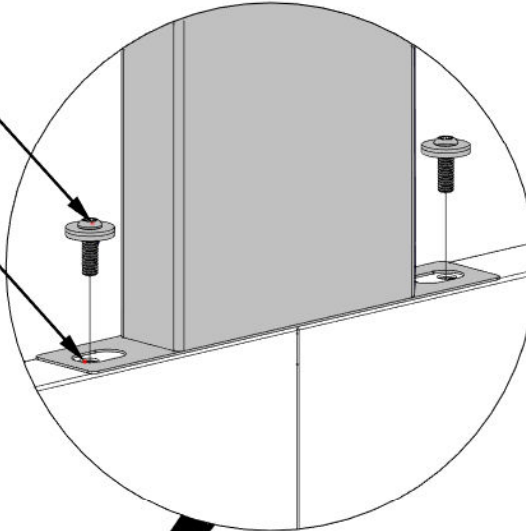

**B06 (x1)
VERTICAL GABLE
SUPPORT**

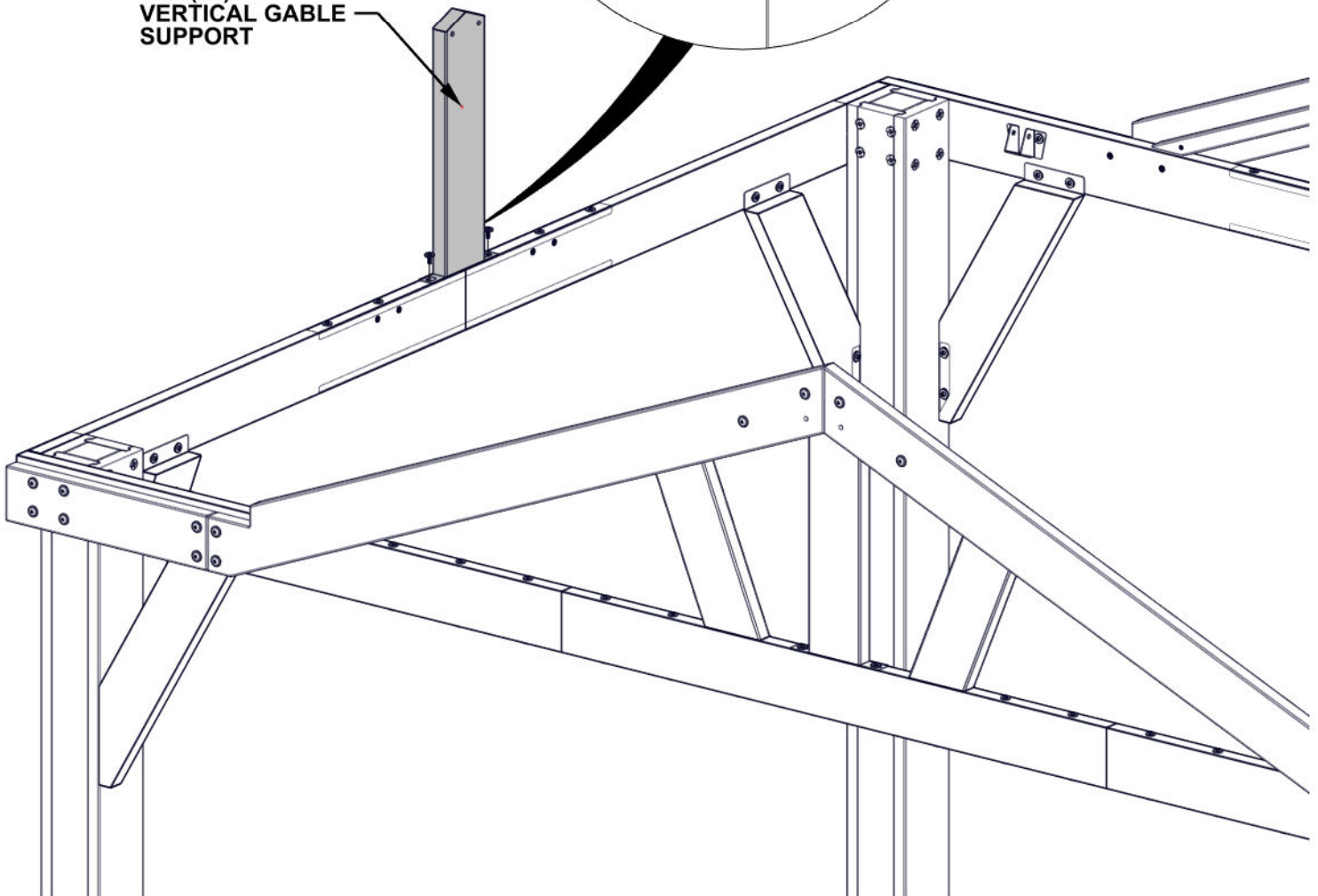

STEP 27 - ROOF ASSEMBLY

Qty	PartNo	Description
4	H101202	TORX PAN HEAD 1/4-20x3/4 ASSY

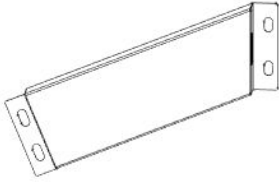

B07 GABLE SUPPORT - A4M05264
(x1) 1 7/16"X5 7/8"X18 1/2" (37x149x470)

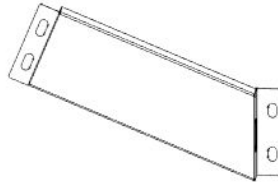

B08 GABLE SUPPORT - A4M05265
(x1) 1 7/16"x5 7/8"x18 1/2" (37x149x470)

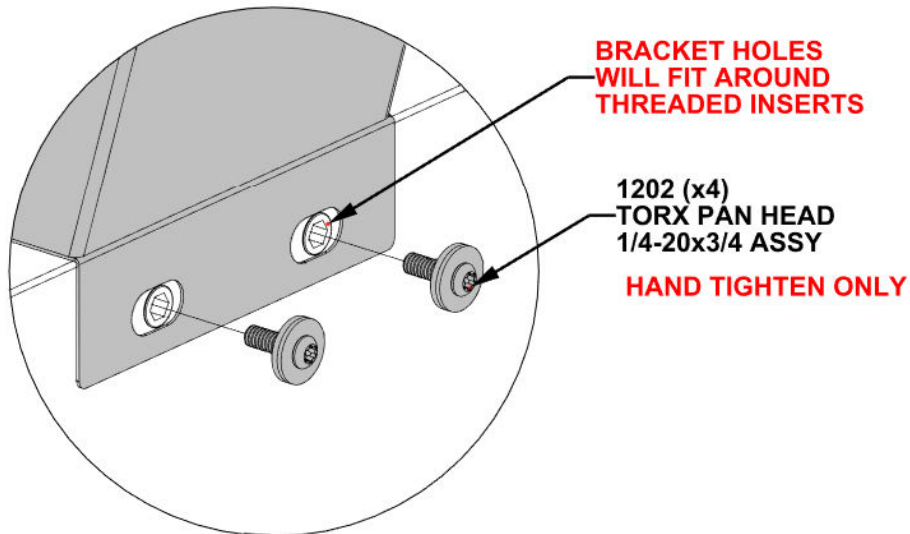

B08 (x1) GABLE SUPPORT

B07 (x1) GABLE SUPPORT

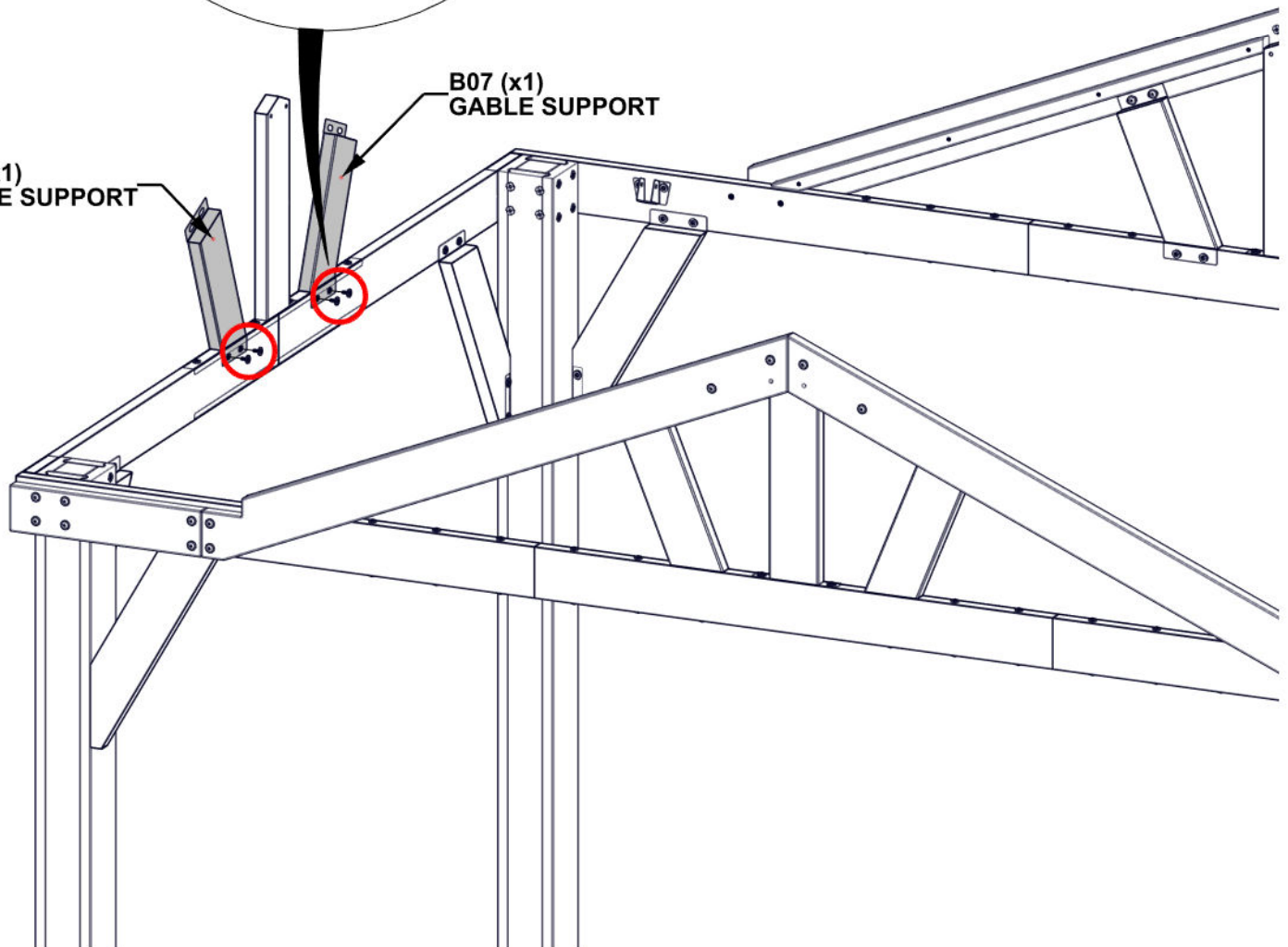

STEP 28 - GABLE ASSEMBLY

Qty	PartNo	Description
2	H100379	T-NUT 5/16 BLK
2	H100407	BOLT WH 5/16x1 1/2 BLK
4	H100821	SCREW PFH 8x2 3/4 BLK



D01 GABLE BOARD - W4L21706
(x1) 1 7/16"x5 1/4"x67 1/8" (36x134x1705)



P03 CLEAT - W4L22266
(x1) 1 7/16"x1 7/16"x57 1/8" (36x36x1450)

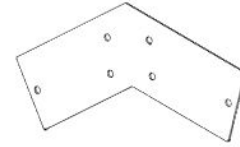

A4M05859 GABLE BRACKET
(x1)

- INSERT T-NUTS FIRST

- ALIGN PILOT HOLES IN CLEAT AND GABLE BOARD.

- FOR EASE OF ASSEMBLY, WE RECOMMEND USING SAW HORSES FOR THIS STEP.

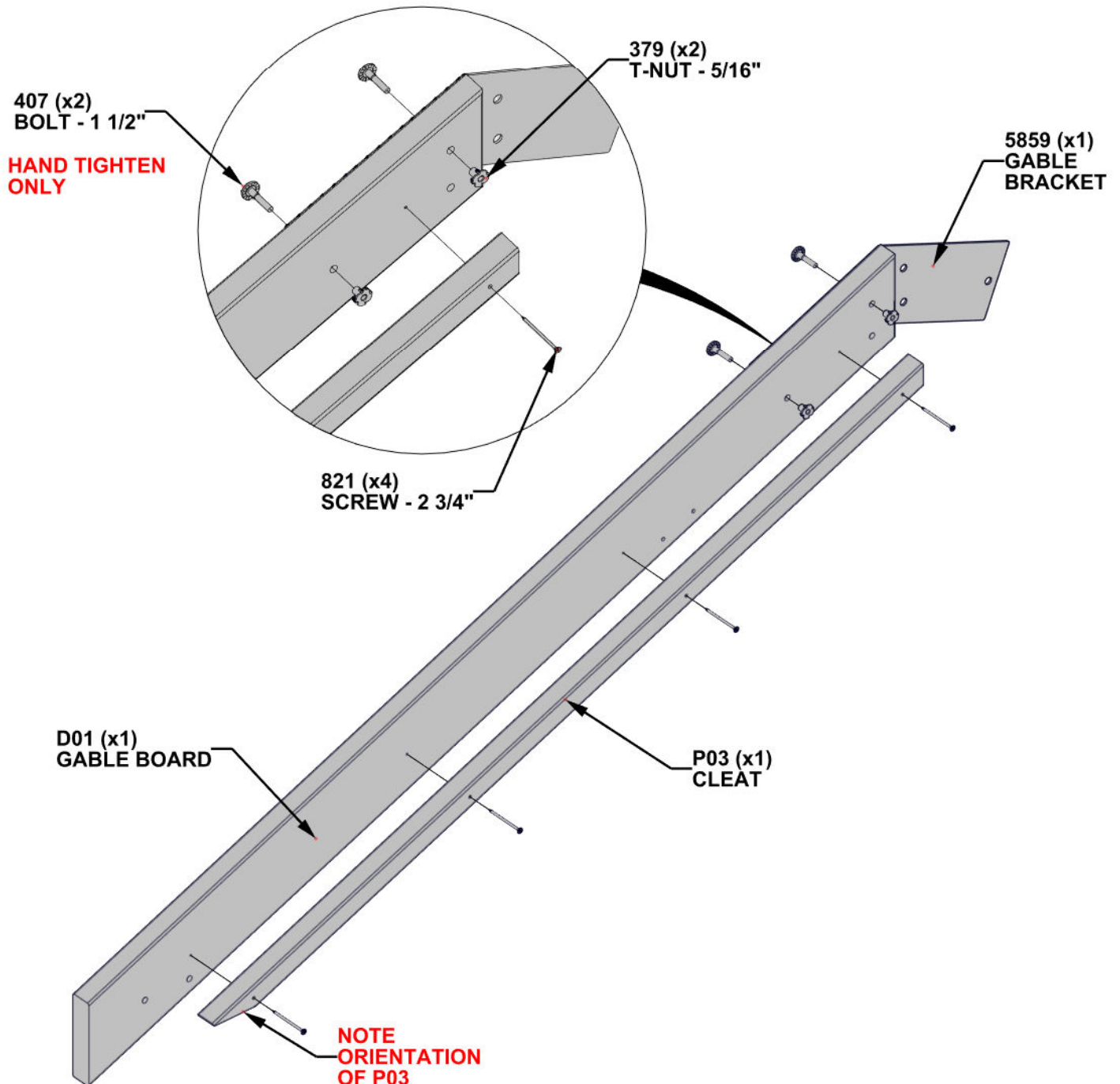

STEP 29 - ROOF ASSEMBLY

Qty	PartNo	Description
2	H100198	WASHER LOCK EXT BLK
2	H100854	LAG SCREW WH 5/16x1 BLK
2	H101058	BOLT WH 5/16x8 3/4 BLK

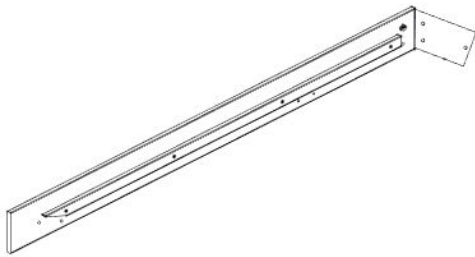

GABLE ASSEMBLY FROM STEP 28

- ALIGN SCREWS WITH PILOT HOLES IN GABLE ASSEMBLY.

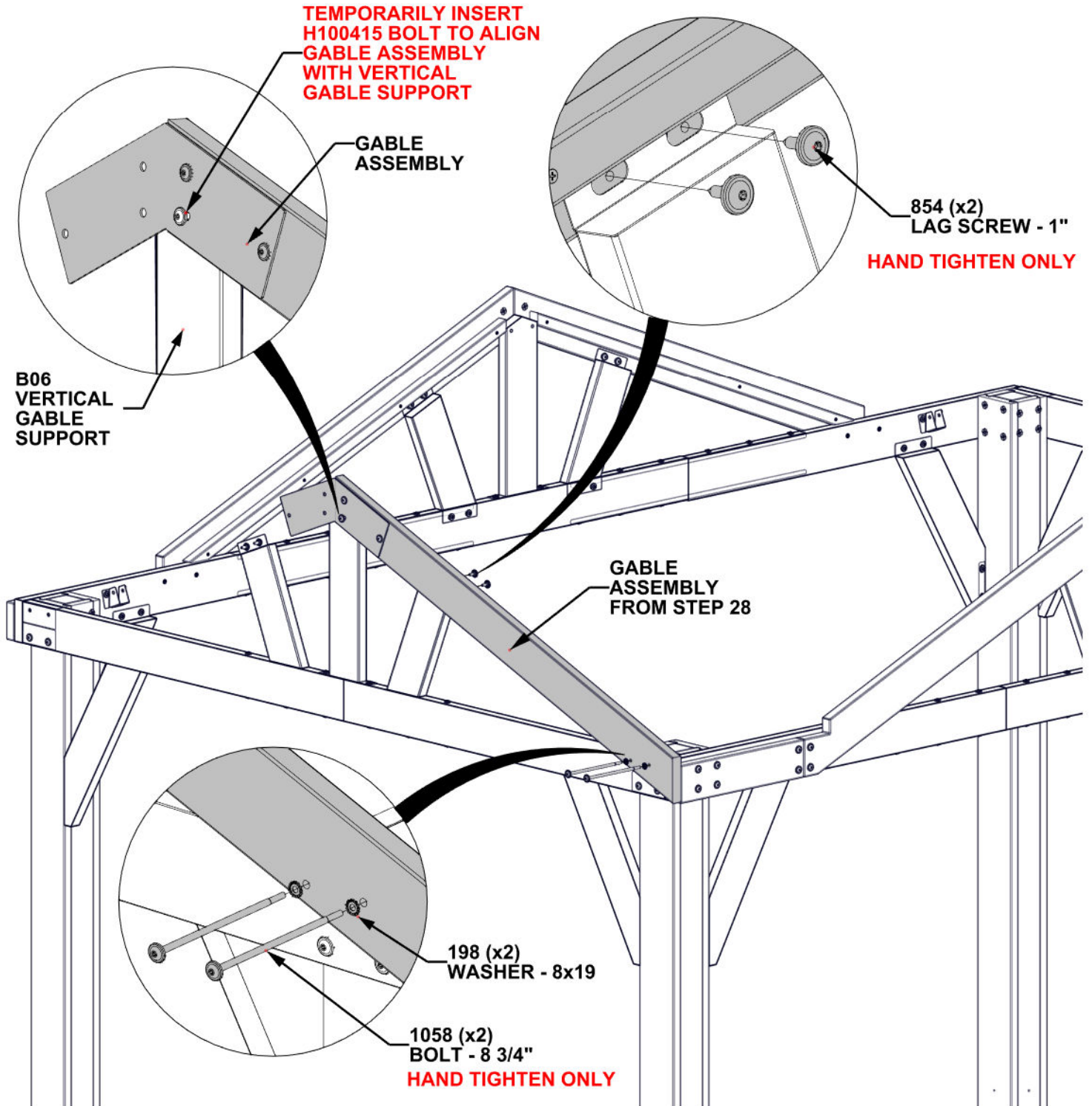

STEP 30 - GABLE ASSEMBLY

Qty	PartNo	Description
2	H100379	T-NUT 5/16 BLK
4	H100821	SCREW PFH 8x2 3/4 BLK



D05 GABLE BOARD - W4L22268
(x1) 1 7/16"x5 1/4"x67 1/8" (36x134x1705)



P03 CLEAT - W4L22266
(x1) 1 7/16"x1 7/16"x57 1/8" (36x36x1450)

- **INSERT T-NUTS FIRST**
- **ALIGN PILOT HOLES IN CLEAT AND GABLE BOARD.**
- **FOR EASE OF ASSEMBLY, WE RECOMMEND USING SAW HORSES FOR THIS STEP.**

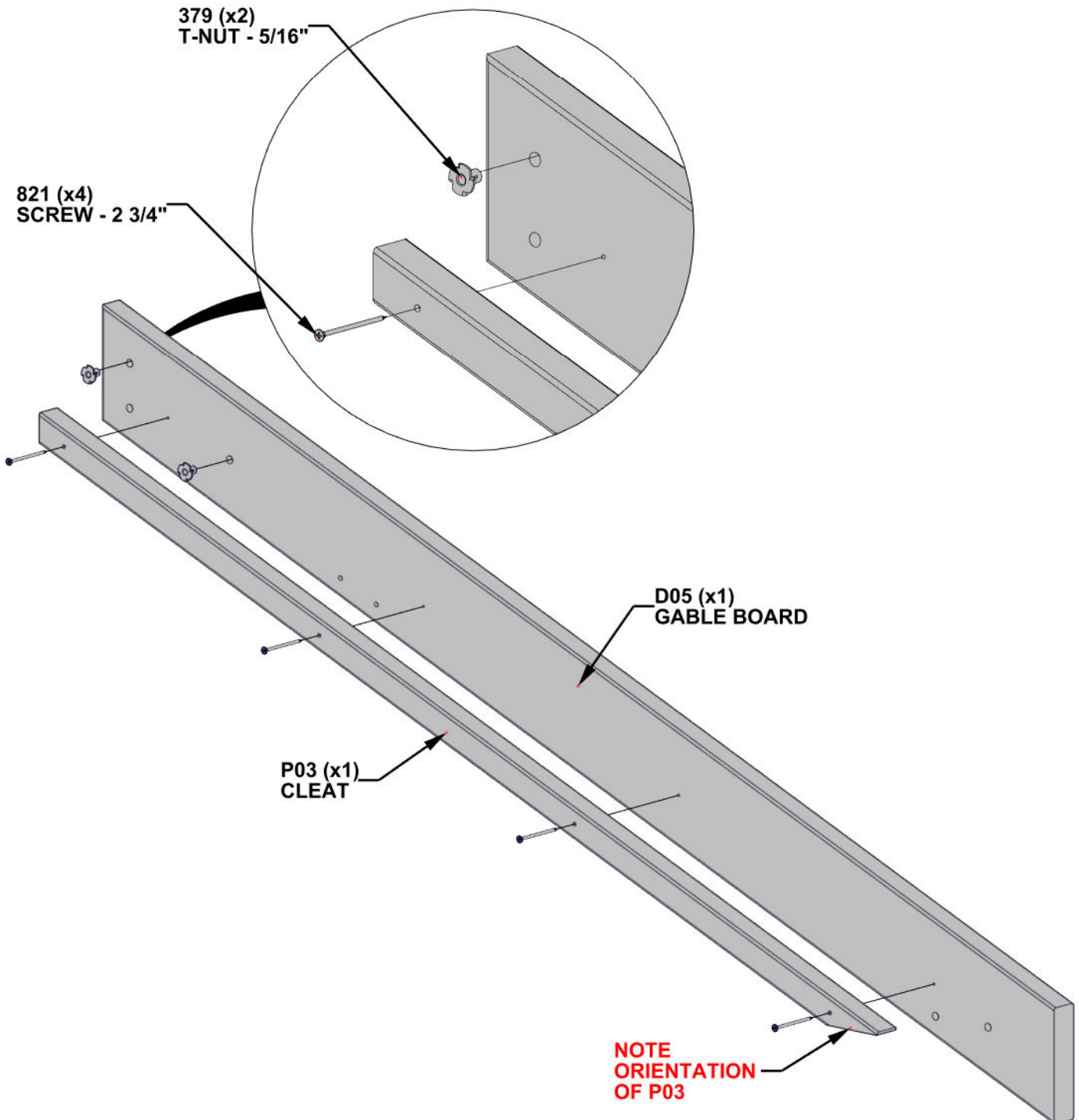

STEP 31 - ROOF ASSEMBLY

Qty	PartNo	Description
2	H100198	WASHER LOCK EXT BLK
2	H100407	BOLT WH 5/16x1 1/2 BLK
2	H100854	LAG SCREW WH 5/16x1 BLK
2	H101058	BOLT WH 5/16x8 3/4 BLK

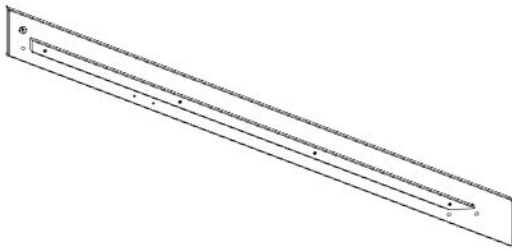

GABLE ASSEMBLY FROM STEP 30

- ALIGN SCREWS WITH PILOT HOLES IN GABLE ASSEMBLY.
- **TIGHTEN ALL HARDWARE.**

TEMPORARILY INSERT H100415 BOLT TO ALIGN GABLE ASSEMBLY WITH GABLE BRACKET AND VERTICAL GABLE SUPPORT

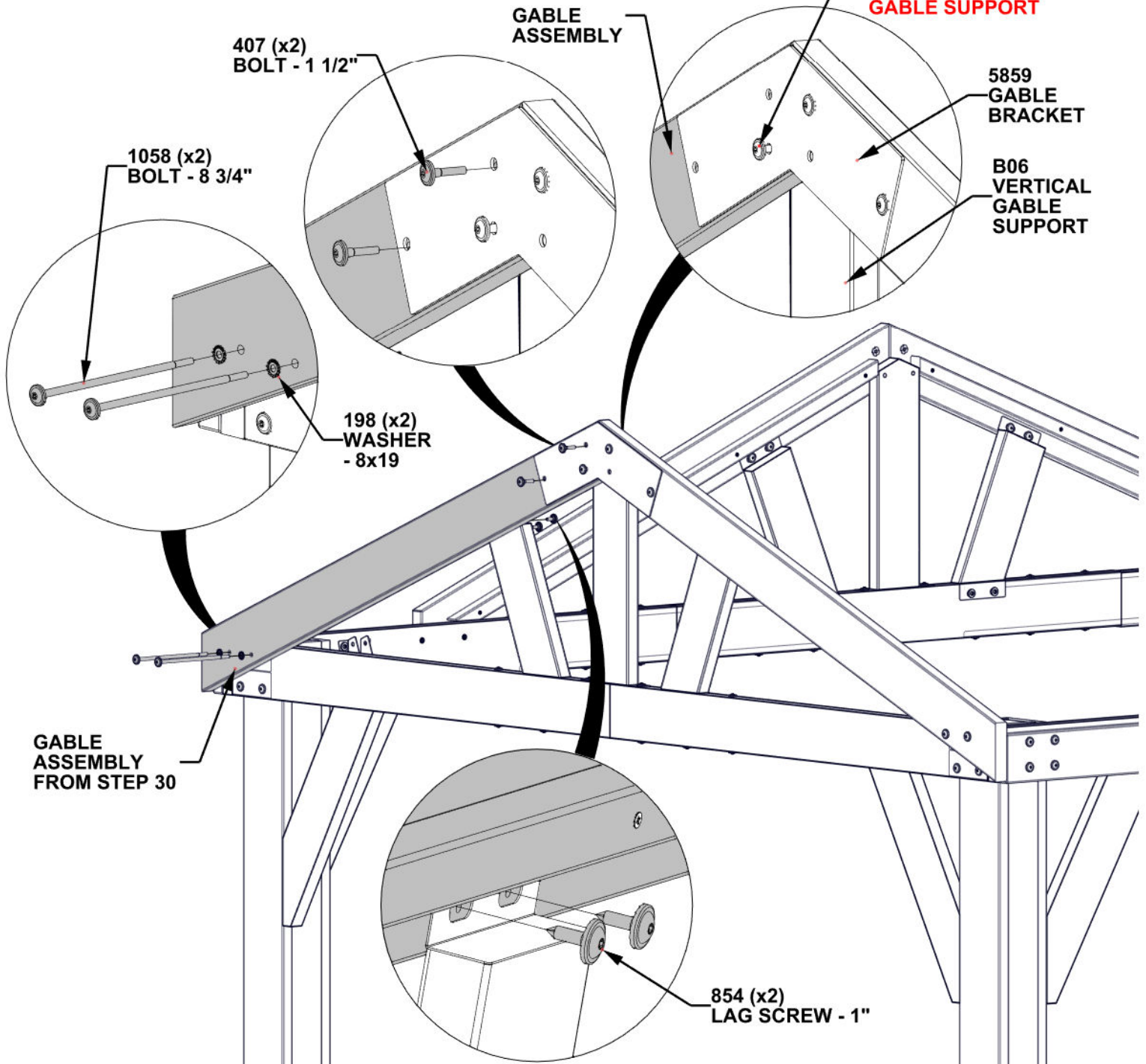

**REPEAT ROOF ASSEMBLY STEPS 26 - 31
TO INSTALL GABLE ON OPPOSITE SIDE**

STEP 32A - RIDGE BEAM ASSEMBLY

Qty	PartNo	Description
8	H100379	T-NUT 5/16 BLK



H01 RIDGE BEAM - W4L21709
(x1) 15/16"x3 3/8"x89 1/2" (24x86x2274)



H02 RIDGE BEAM - W4L21710
(x1) 15/16"x3 3/8"x74 7/16" (24x86x1890)

- INSERT T-NUTS FIRST.

- FOR EASE OF ASSEMBLY, WE RECOMMEND USING SAW HORSES FOR STEP 32A-33.

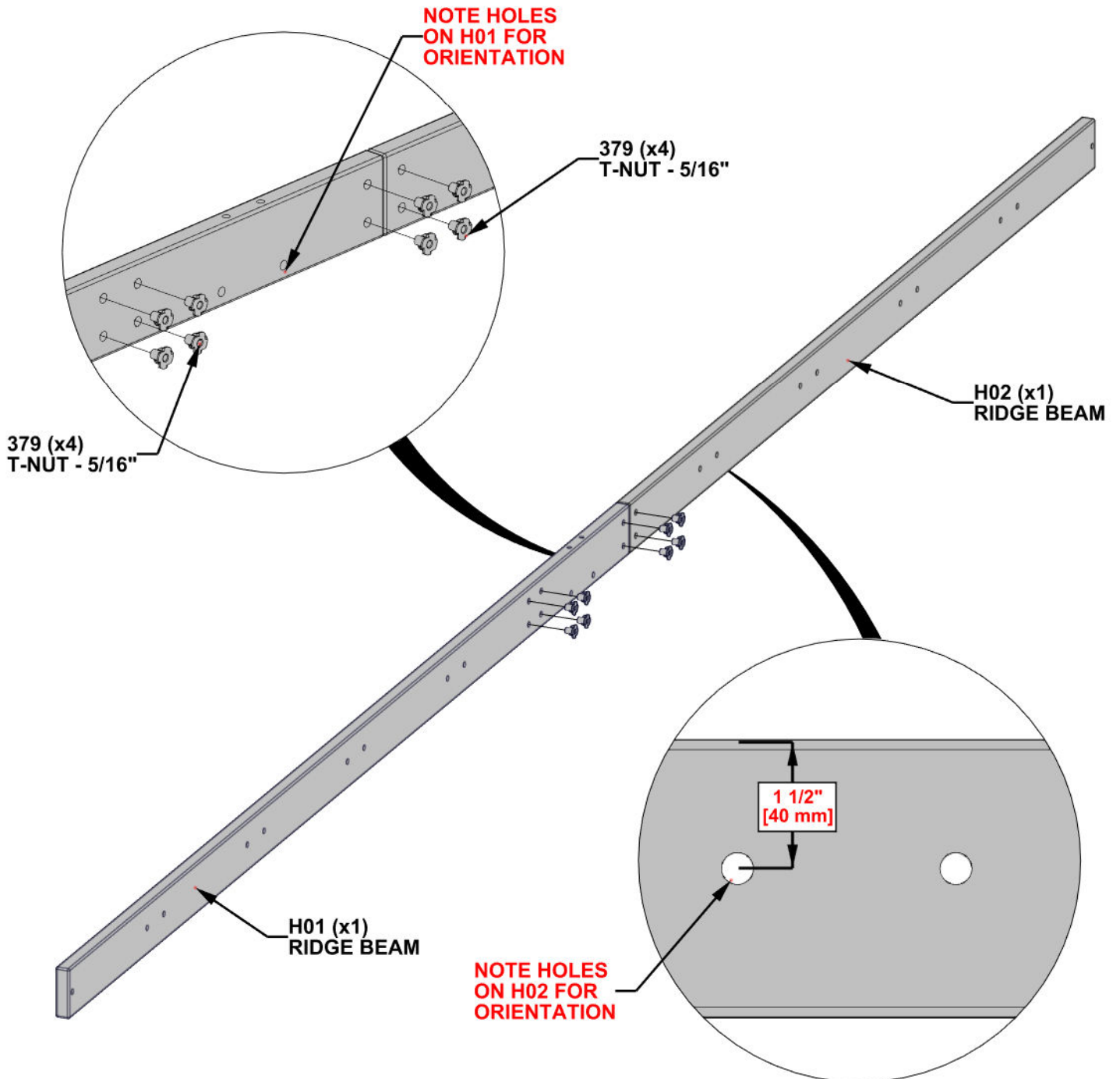

STEP 32B - RIDGE BEAM ASSEMBLY

Qty	PartNo	Description
8	H100198	WASHER LOCK EXT BLK
8	H100378	BOLT WH 5/16x1 3/4 BLK



H01 RIDGE BEAM - W4L21709
(x1) 15/16"x3 3/8"x89 1/2" (24x86x2274)



H02 RIDGE BEAM - W4L21710
(x1) 15/16"x3 3/8"x74 7/16" (24x86x1890)

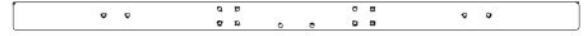

A4M05260 RIDGE BRACE
(x1)

- ALIGN THRU HOLES IN RIDGE BRACE WITH THE HOLES IN FOUR RIDGE BEAMS.

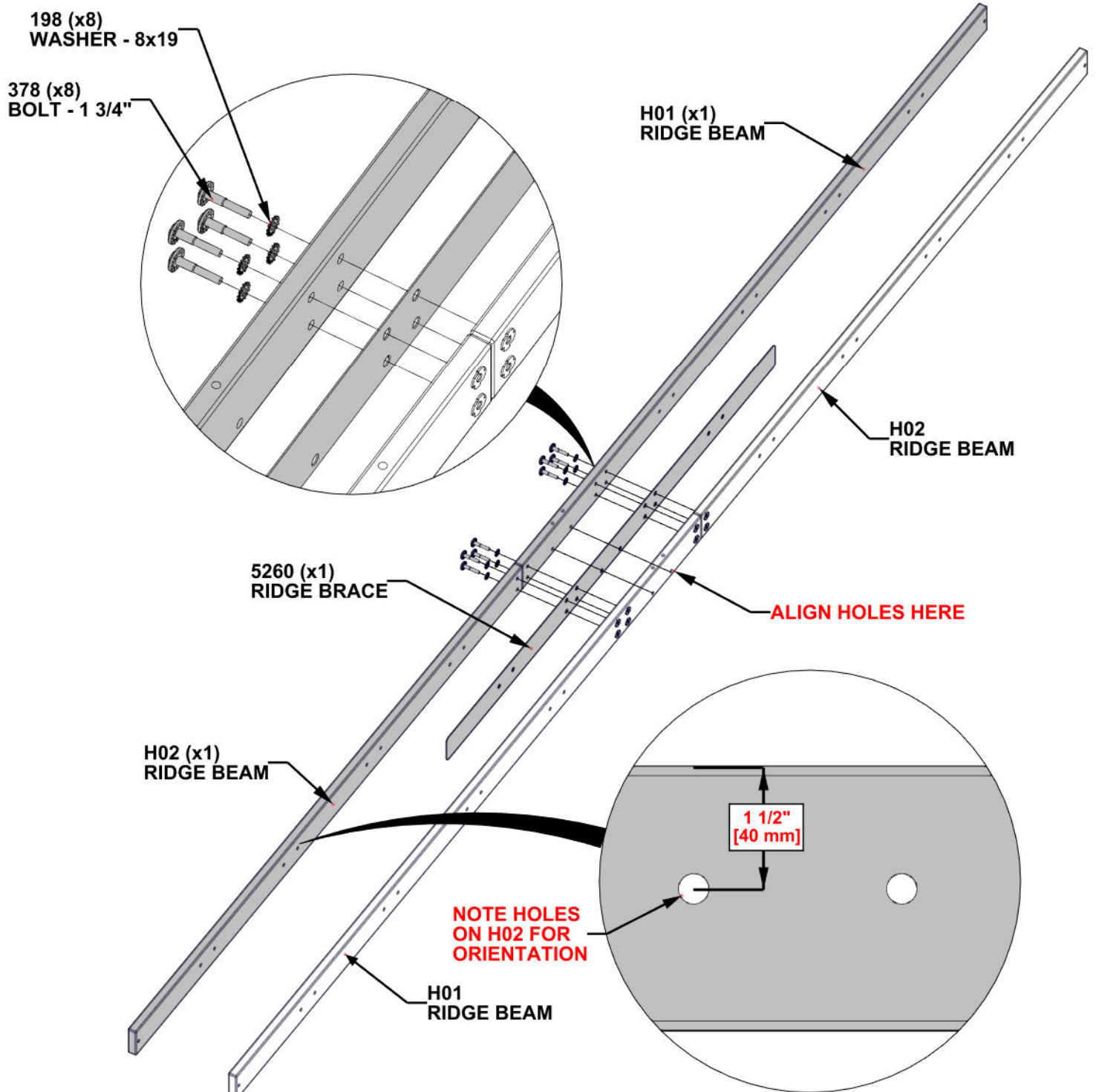

STEP 32C - RIDGE BEAM ASSEMBLY

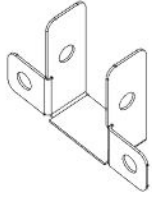

A4M01148 TRUSS BRACKET
(x2)

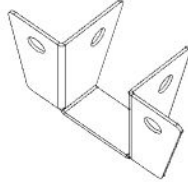

A4M05266 RAFTER BRACKET
(x16)

Qty	PartNo	Description
16	H100194	BOLT WH 5/16x2 1/2 BLK
2	H100195	BOLT WH 5/16x2 3/4 BLK
2	H100478	WASHER FLAT 8x27 BLK
18	H100479	NUT LOCK 5/16 BLK
16	H100770	WASHER FLAT 5/16 BLK

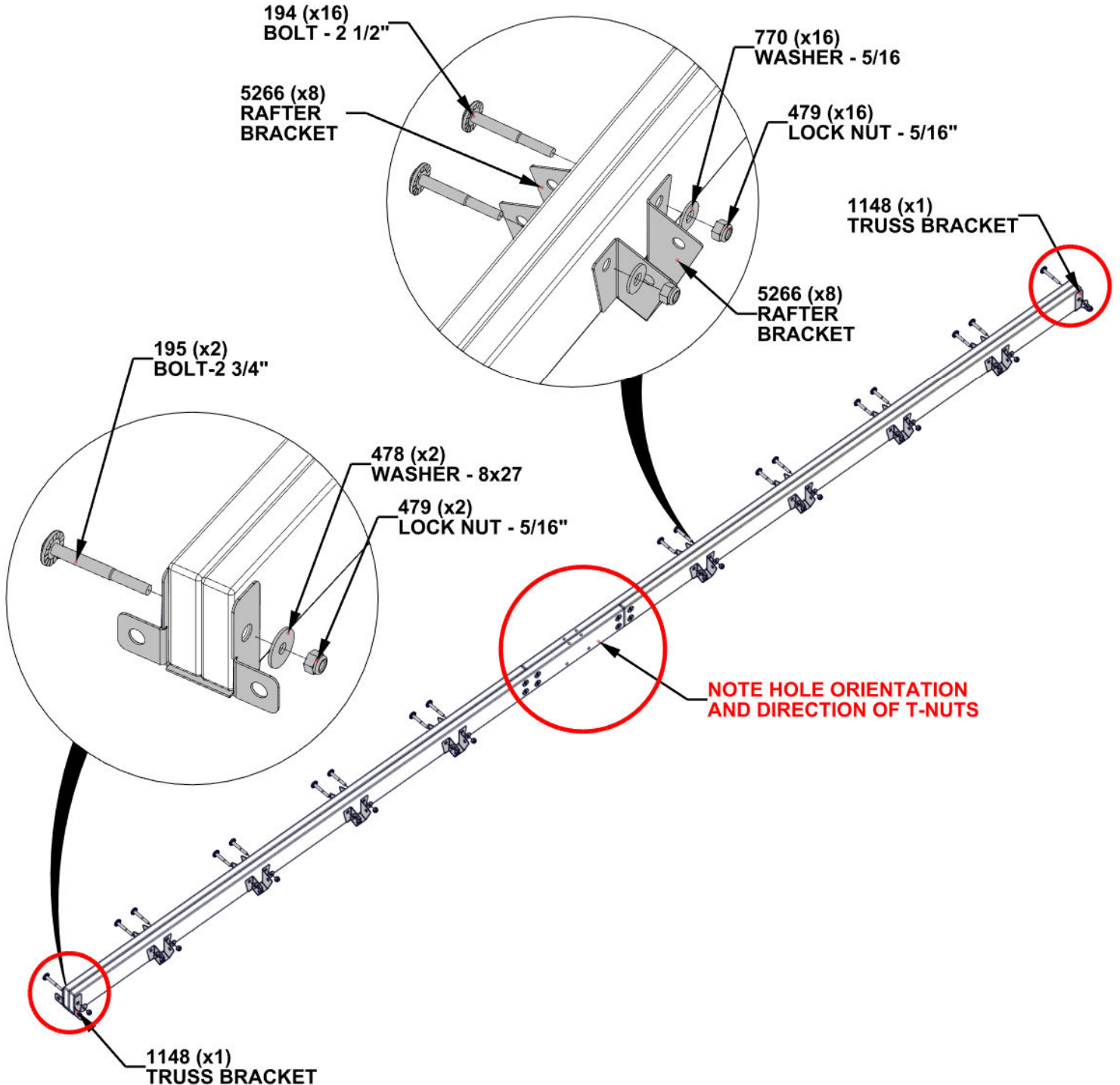

STEP 32D - RIDGE BEAM ASSEMBLY

Qty	PartNo	Description
4	H100630	WASHER FLAT 8x19 BLK
4	H100653	NUT LOCK 1/4 BLK
4	H101461	BOLT CARRIAGE 5/16X 6 1/2 BLK

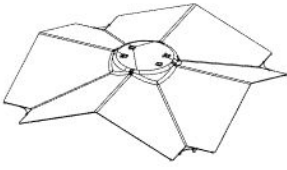

A4M05858 RIDGE CAP SPLICE
(x1)

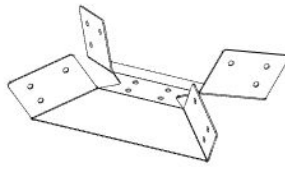

A4M04103 RIDGE TIE BRACKET
(x1)



A4M05857 SUPPORT RING
(x4)

- HAND TIGHTEN ONLY.

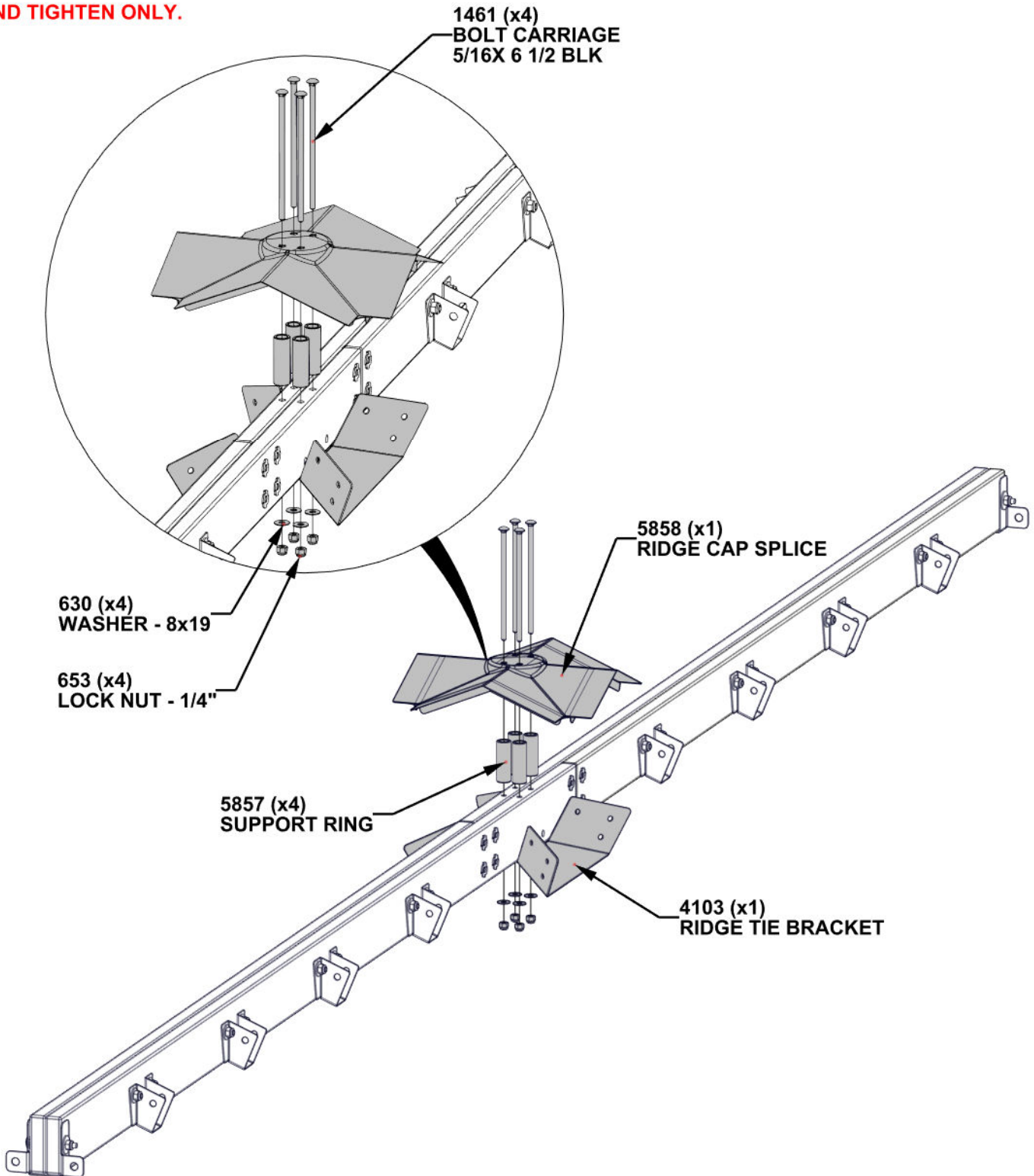

STEP 33 - RIDGE BEAM ASSEMBLY



H03 RIDGE BEAM - W4L21711
(x4) 15/16"x3 3/8"x56 1/16" (24x86x1424)

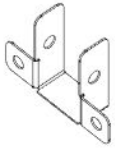

A4M01148 TRUSS BRACKET
(x4)

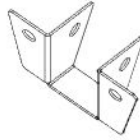

A4M05266 RAFTER BRACKET
(x12)

Qty	PartNo	Description
12	H100194	BOLT WH 5/16x2 1/2 BLK
4	H100195	BOLT WH 5/16x2 3/4 BLK
2	H100478	WASHER FLAT 8x27 BLK
16	H100479	NUT LOCK 5/16 BLK
14	H100770	WASHER FLAT

- REPEAT THIS STEP 2 TIMES.

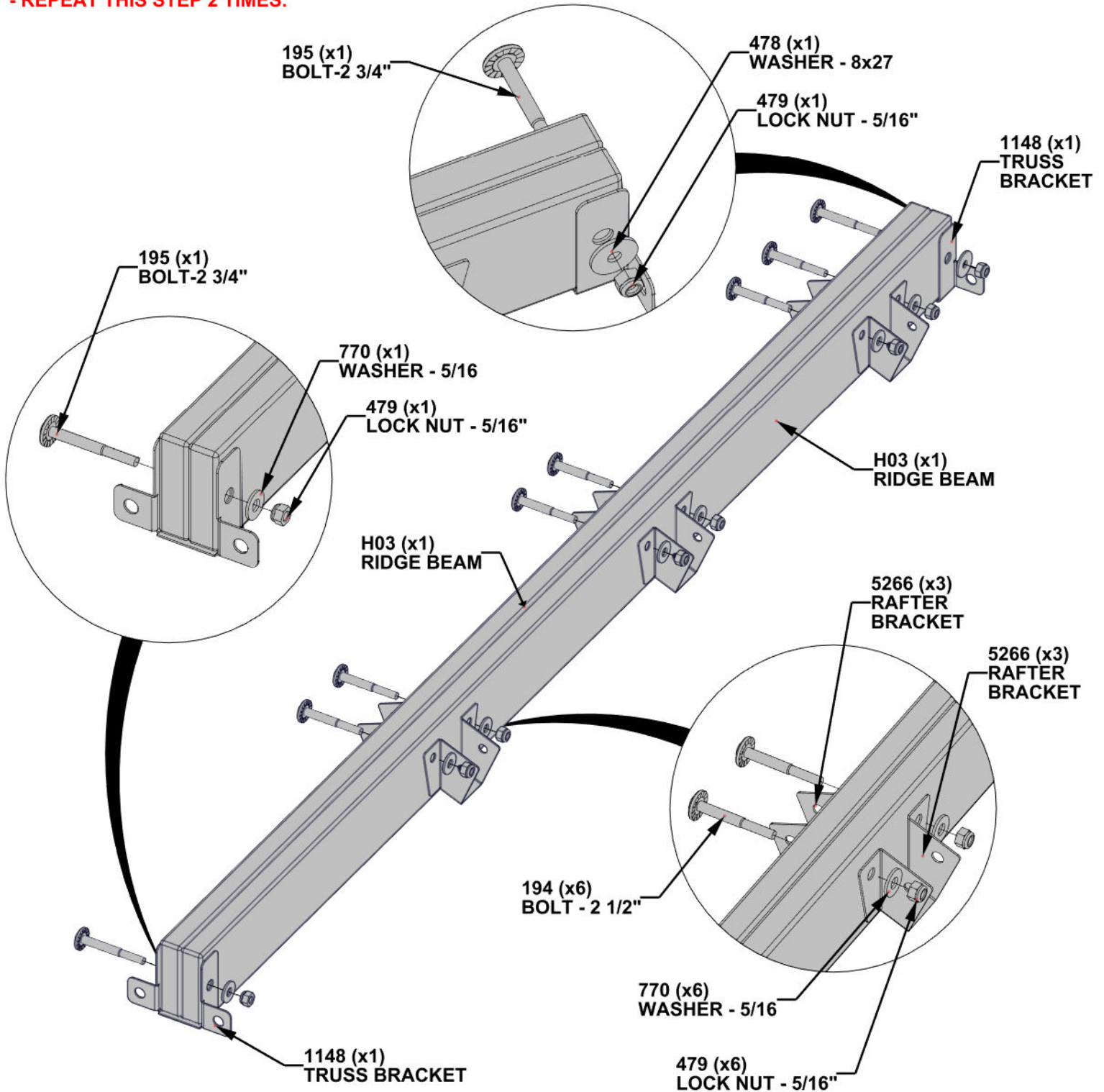

STEP 34 - ROOF ASSEMBLY

Qty	PartNo	Description
4	H100415	BOLT WH 5/16x3 3/4 BLK
4	H100479	NUT LOCK 5/16 BLK
4	H100770	WASHER FLAT 5/16 BLK

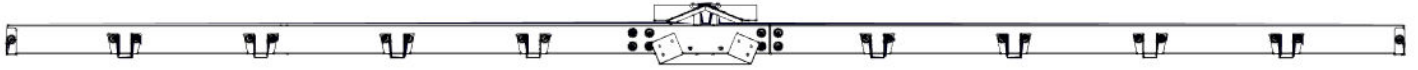

RIDGE BEAM ASSEMBLY FROM STEP 32A-32D

- WITH AT LEAST TWO OTHER PEOPLE, ALIGN HOLES IN TRUSS BRACKET AND GABLE ASSEMBLY, ATTACH RIDGE BEAM TO GABLE.

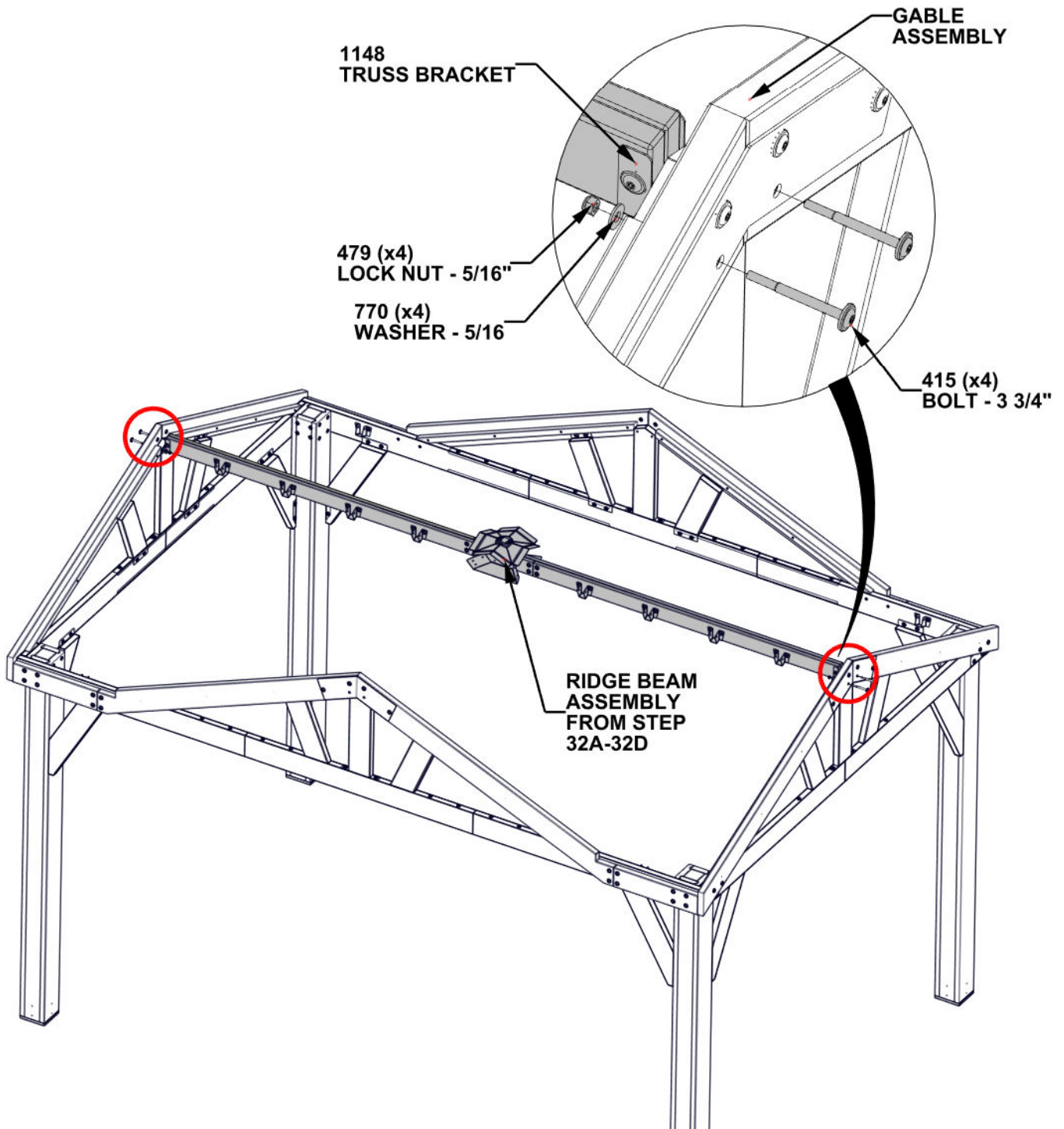

STEP 35 - ROOF ASSEMBLY

Qty	PartNo	Description
2	H100195	BOLT WH 5/16x2 3/4 BLK
4	H100415	BOLT WH 5/16x3 3/4 BLK
6	H100479	NUT LOCK 5/16 BLK
6	H100770	WASHER FLAT 5/16 BLK

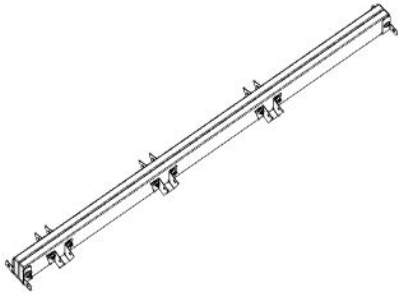

RIDGE BEAM ASSEMBLY FROM STEP 33

- WITH AT LEAST TWO OTHER PEOPLE, ALIGN HOLES IN TRUSS BRACKET AND RIDGE BEAM ASSEMBLY (H03), ALIGN HOLES IN TRUSS BRACKET AND GABLE ASSEMBLY.
- ATTACH RIDGE BEAM TO RIDGE BEAM ASSEMBLY (H03) AND GABLE.

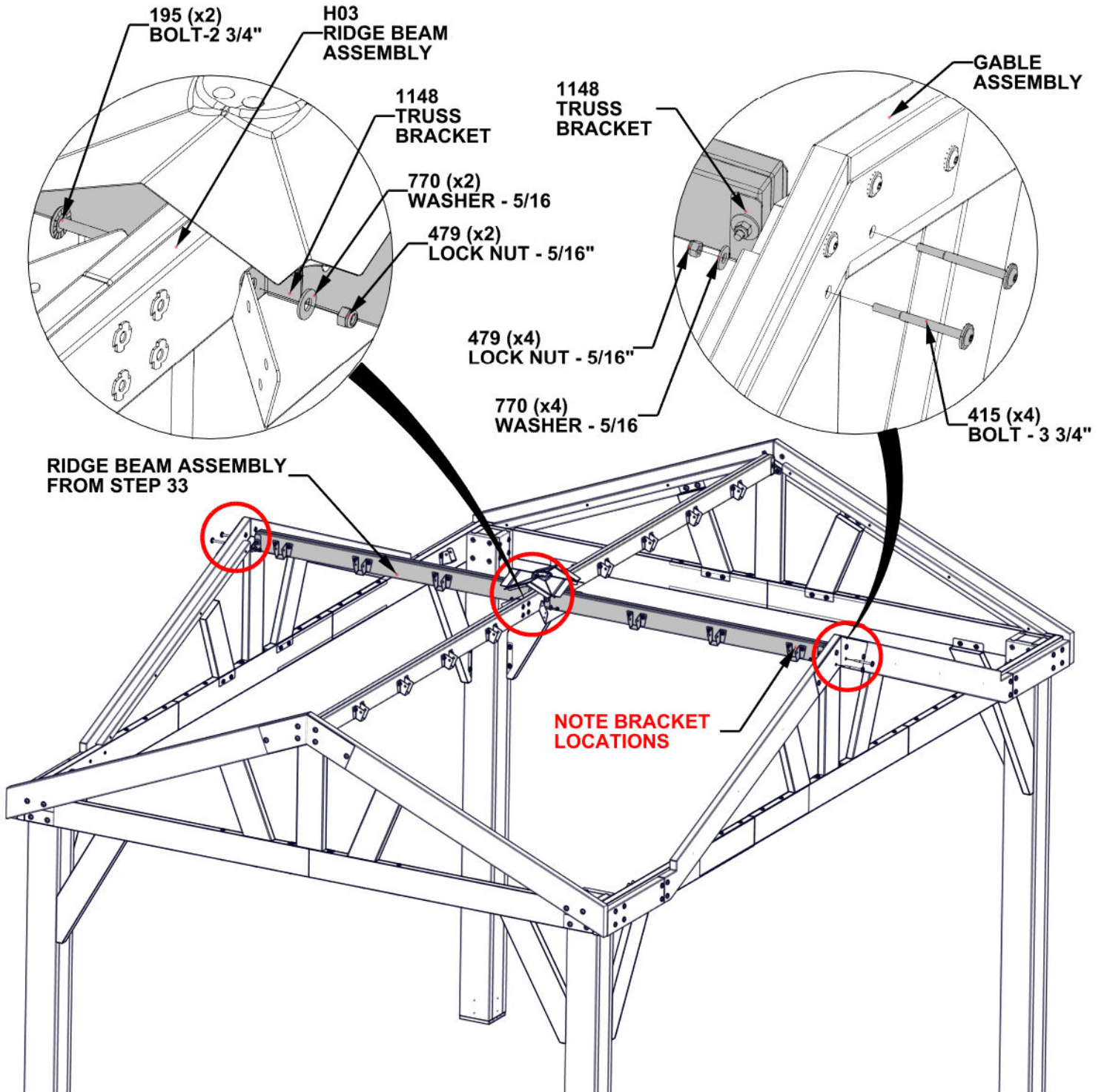

STEP 36 - VALLEY BOARD ASSEMBLY

Qty	PartNo	Description
12	H100205	BOLT WH 5/16x2 1/4 BLK
6	H100398	TNUT-1/4" BLK
12	H100478	WASHER FLAT 8x27 BLK
12	H100479	NUT LOCK 5/16 BLK

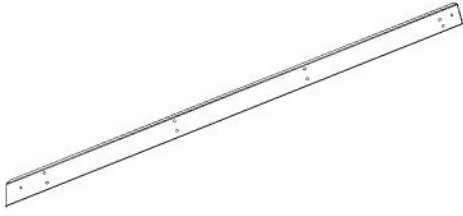

E01 VALLEY BOARD - W4L21712
(x2) 1 7/16"x3 3/8"x82 15/16" (36x86x2104)

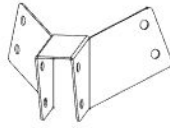

A4M05845 RAFTER TIE
(x6)

- INSERT T-NUTS FIRST.
- REPEAT THIS STEP 2 TIMES.

- FOR EASE OF ASSEMBLY, WE RECOMMEND USING SAW HORSES FOR STEP 36-37.

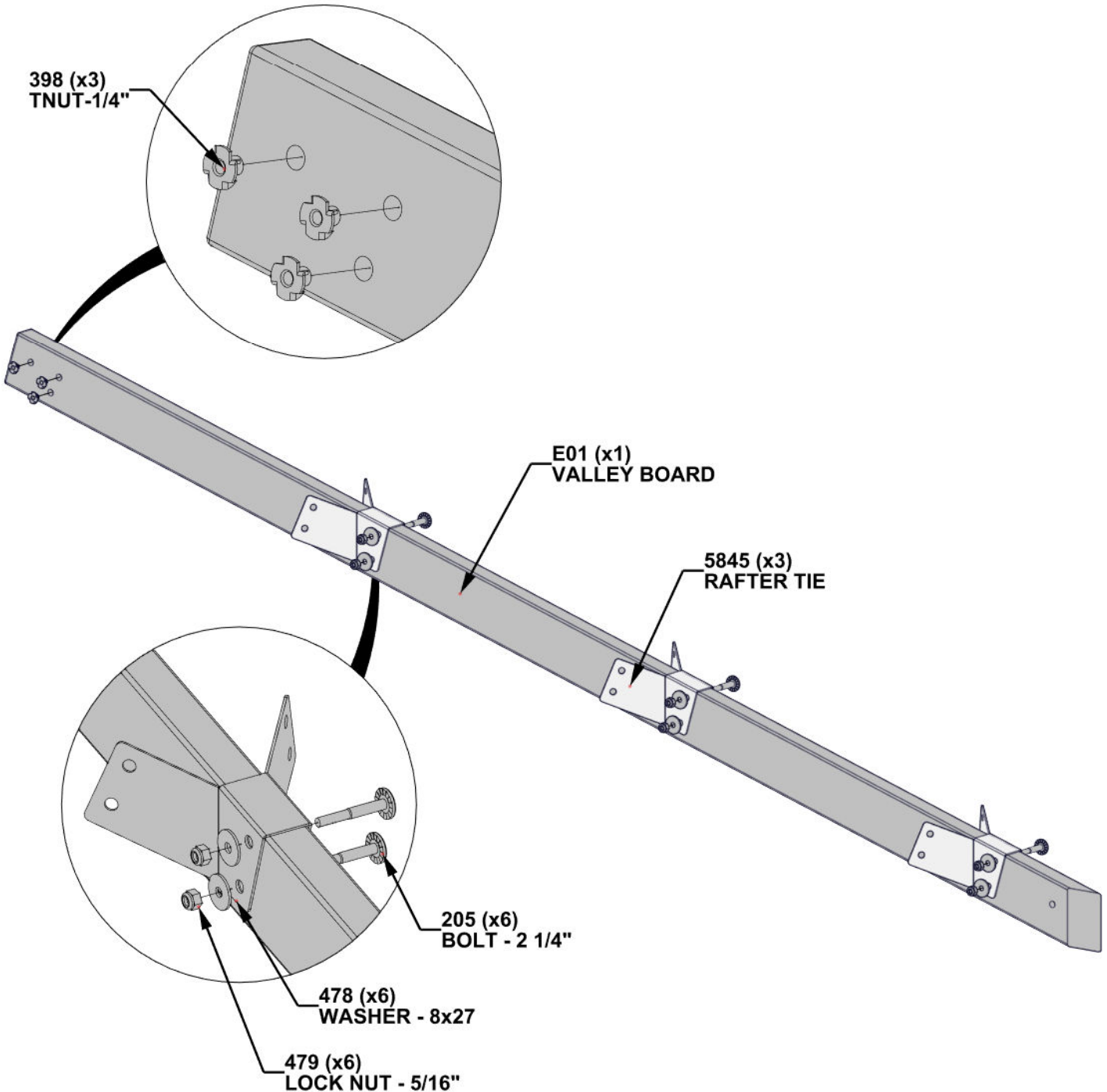

STEP 37 - VALLEY BOARD ASSEMBLY

Qty	PartNo	Description
12	H100205	BOLT WH 5/16x2 1/4 BLK
6	H100398	TNUT-1/4" BLK
12	H100478	WASHER FLAT 8x27 BLK
12	H100479	NUT LOCK 5/16 BLK

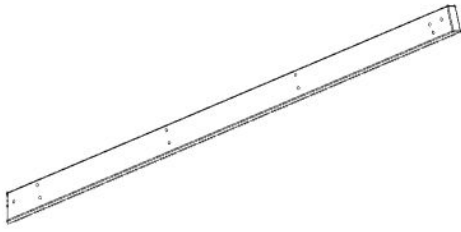

E15 VALLEY BOARD - W4L22269
(x2) 1 7/16"x3 3/8"x83 1/4" (36x86x2104)

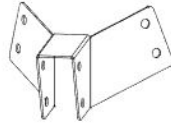

A4M05845 RAFTER TIE
(x6)

- INSERT T-NUTS FIRST.
- REPEAT THIS STEP 2 TIMES.

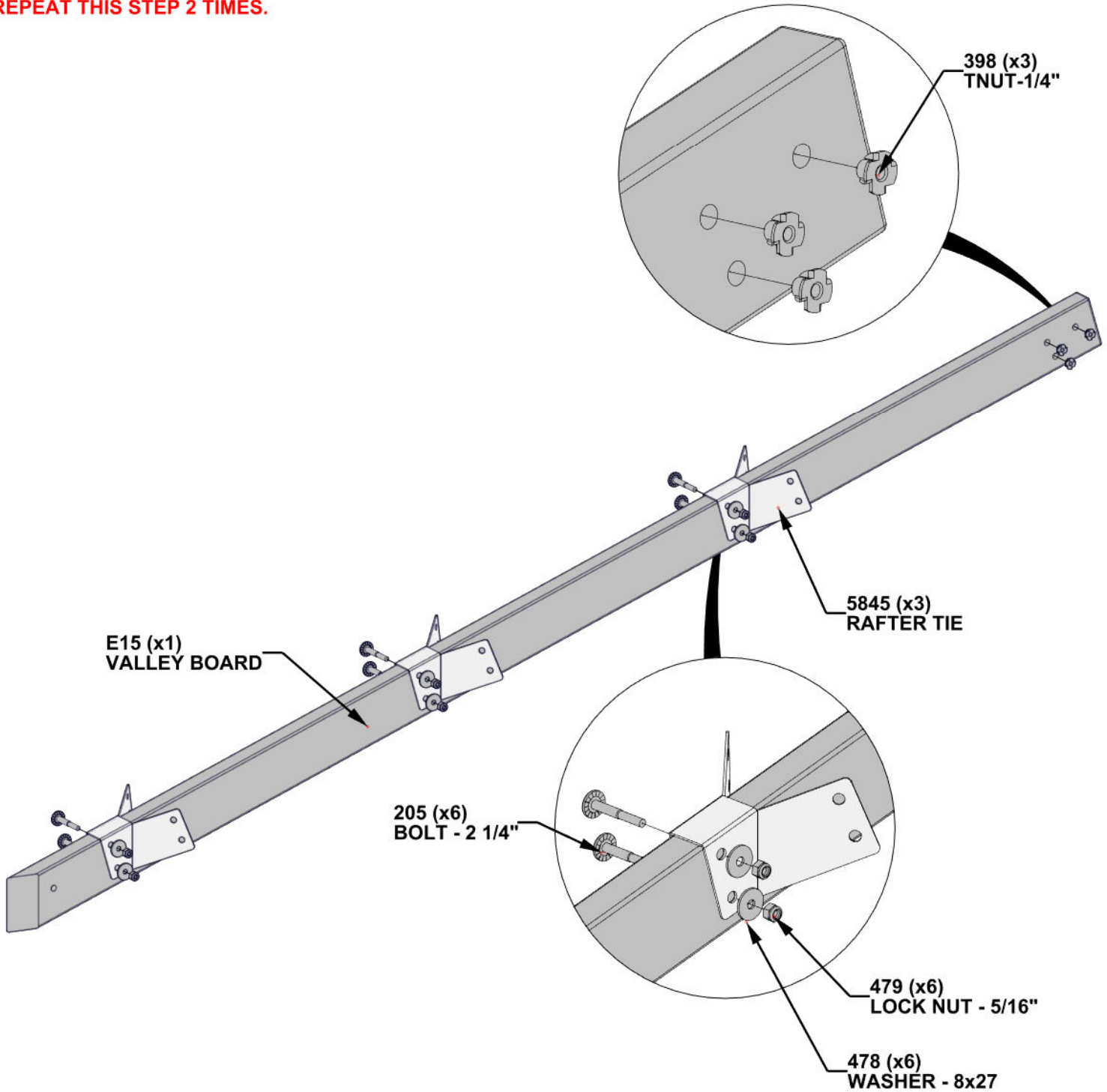

STEP 38A - ROOF ASSEMBLY

Qty	PartNo	Description
8	H101202	TORX PAN HEAD 1/4-20x3/4 ASSY

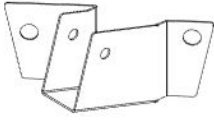

A4M05846 VALLEY CLIP
(x2)

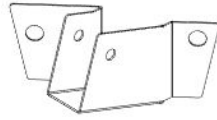

A4M05847 VALLEY CLIP
(x2)

**BRACKET HOLES
WILL FIT AROUND
THREADED INSERTS**

1202 (x4)
TORX PAN HEAD
1/4-20x3/4 ASSY

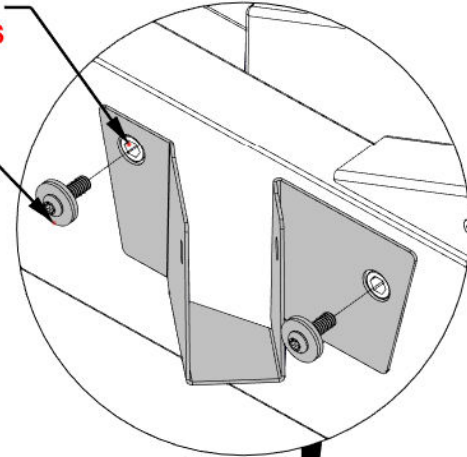

1202 (x4)
TORX PAN HEAD
1/4-20x3/4 ASSY

**BRACKET HOLES
WILL FIT AROUND
THREADED INSERTS**

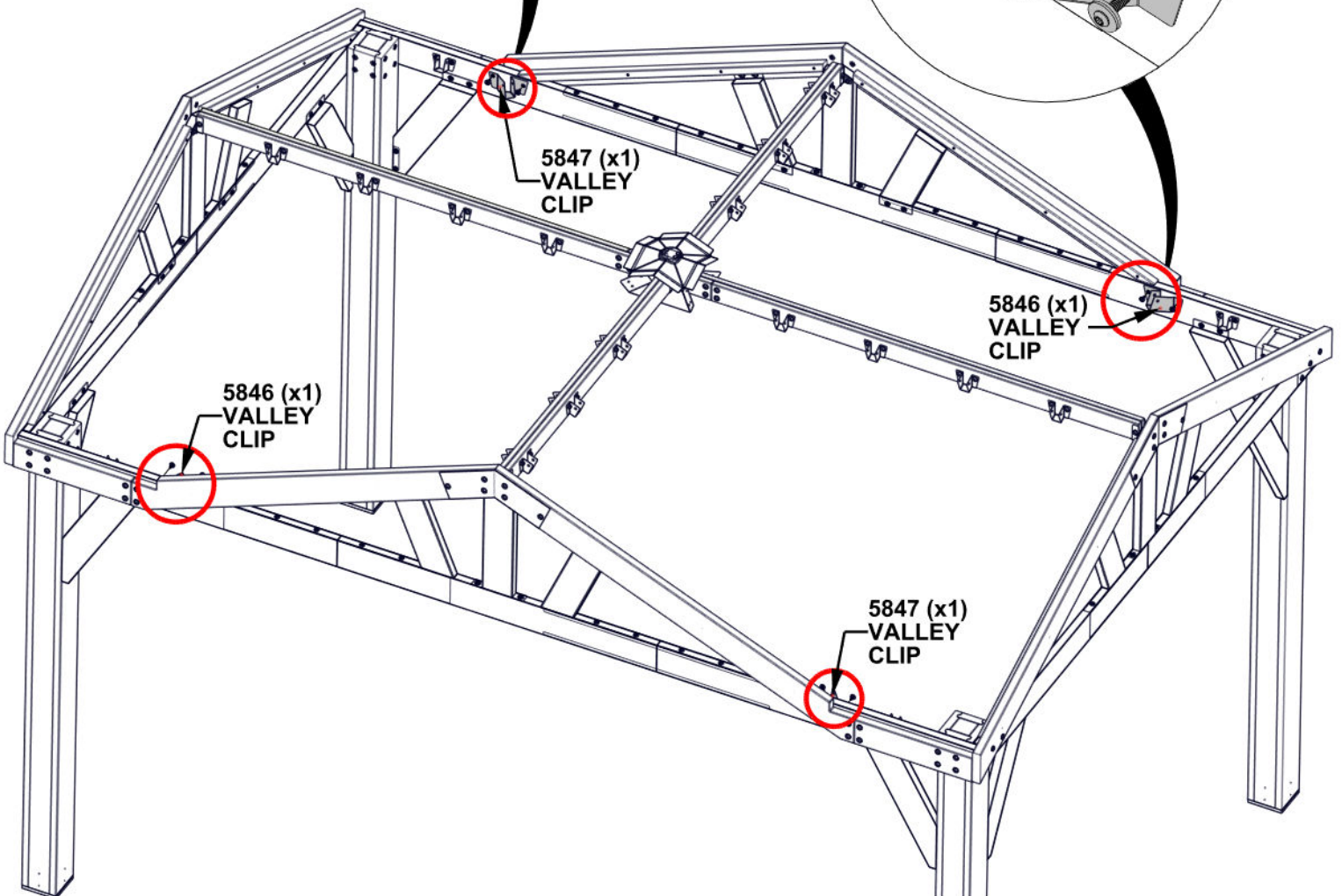
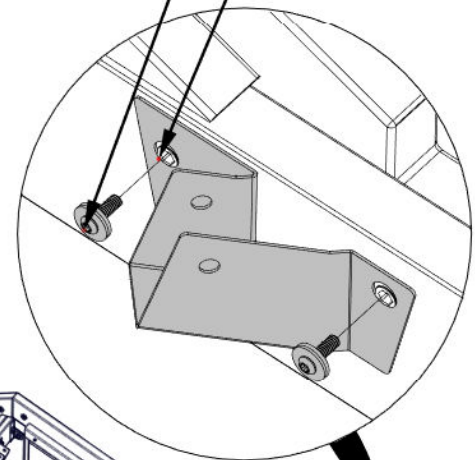

STEP 38B - ROOF ASSEMBLY

Qty	PartNo	Description
2	H100205	BOLT WH 5/16x2 1/4 BLK
6	H100406	BOLT WH 1/4x1 1/2 BLK LT
2	H100478	WASHER FLAT 8x27 BLK
2	H100479	NUT LOCK 5/16 BLK

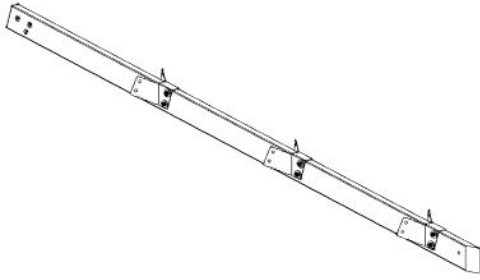

VALLEY BOARD ASSEMBLY FROM STEP 36

- WITH AT LEAST TWO OTHER PEOPLE, ALIGN HOLES IN VALLEY CLIP AND VALLEY BOARD, ALIGN HOLES IN VALLEY BOARD AND RIDGE TIE BRACKET.
- ATTACH VALLEY BOARD TO VALLEY CLIP AND RIDGE TIE BRACKET.

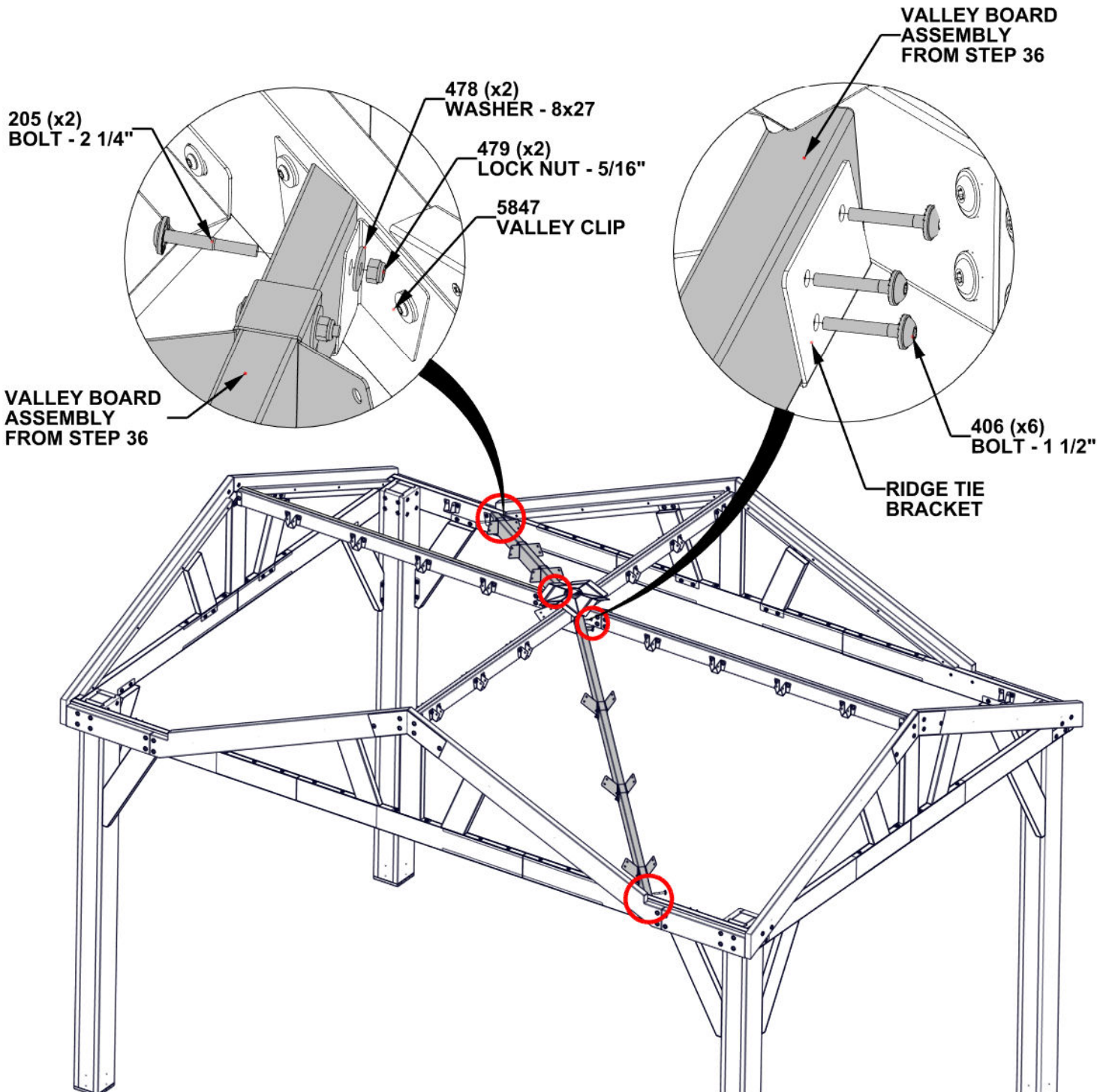

STEP 38C - ROOF ASSEMBLY

Qty	PartNo	Description
2	H100205	BOLT WH 5/16x2 1/4 BLK
6	H100406	BOLT WH 1/4x1 1/2 BLK LT
2	H100478	WASHER FLAT 8x27 BLK
2	H100479	NUT LOCK 5/16 BLK

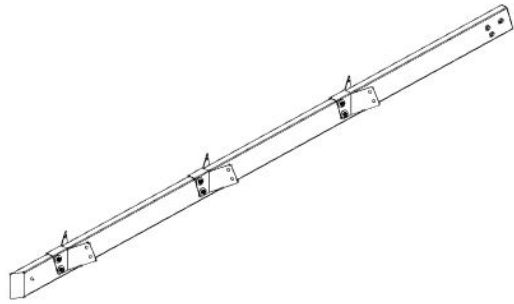

VALLEY BOARD ASSEMBLY FROM STEP 37

- WITH AT LEAST TWO OTHER PEOPLE, ALIGN HOLES IN VALLEY CLIP AND VALLEY BOARD, ALIGN HOLES IN VALLEY BOARD AND RIDGE TIE BRACKET.
- ATTACH VALLEY BOARD TO VALLEY CLIP AND RIDGE TIE BRACKET.

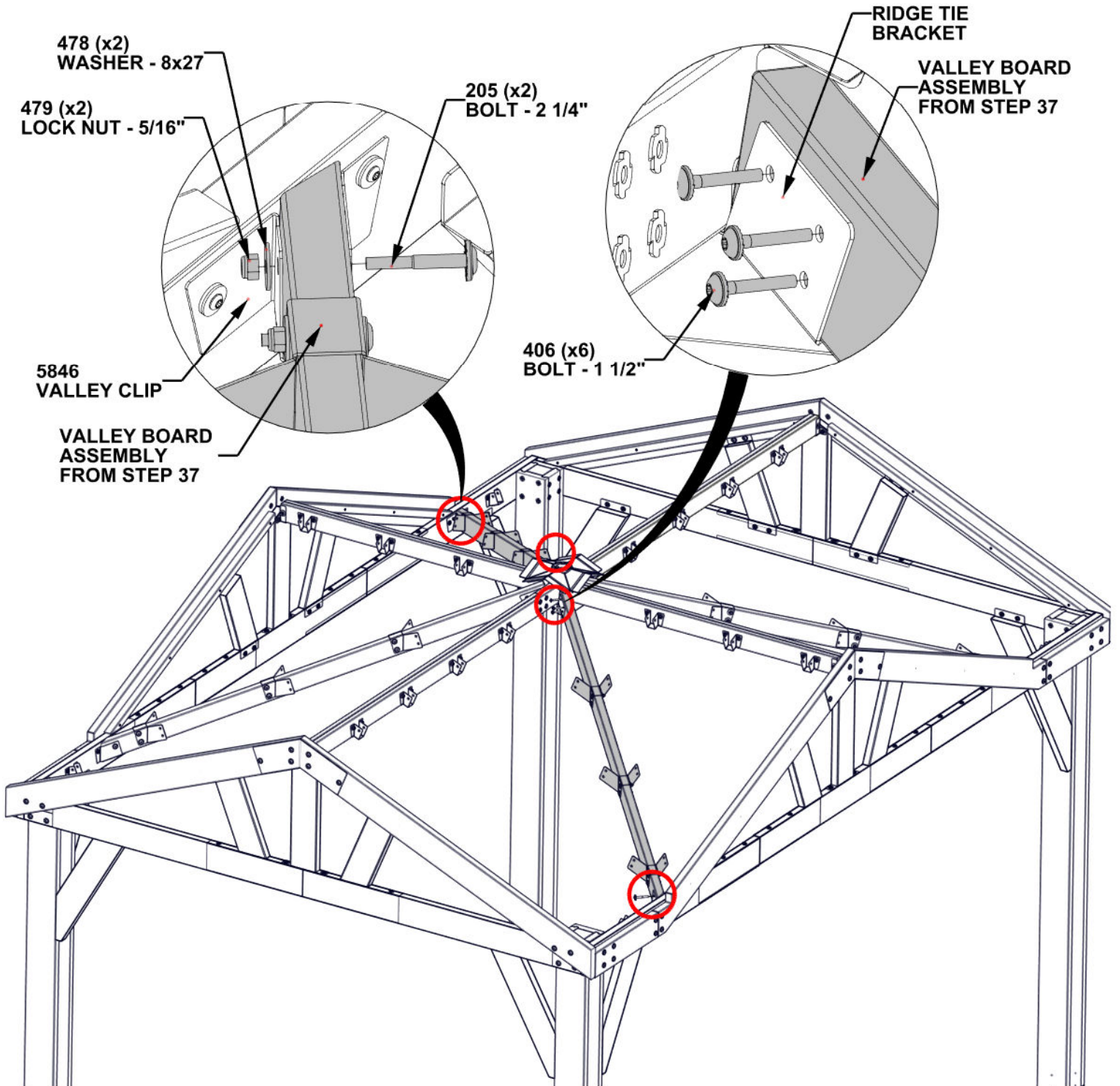

STEP 39A - ROOF ASSEMBLY

Qty	PartNo	Description
6	H100379	T-NUT 5/16 BLK

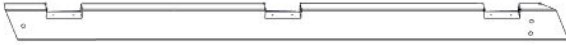

E06 RAFTER - W4L21720
(x1) 1 7/16"x3 3/8"x55 7/8" (36x86x1415)



E07 RAFTER - W4L21721
(x1) 1 7/16"x3 3/8"x38 9/16" (36x86x976)



E08 RAFTER - W4L21722
(x1) 1 7/16"x3 3/8"x21 1/4" (36x86x536)

- INSERT T-NUTS FIRST.

- FOR EASE OF ASSEMBLY, WE RECOMMEND USING SAW HORSES FOR THIS STEP.

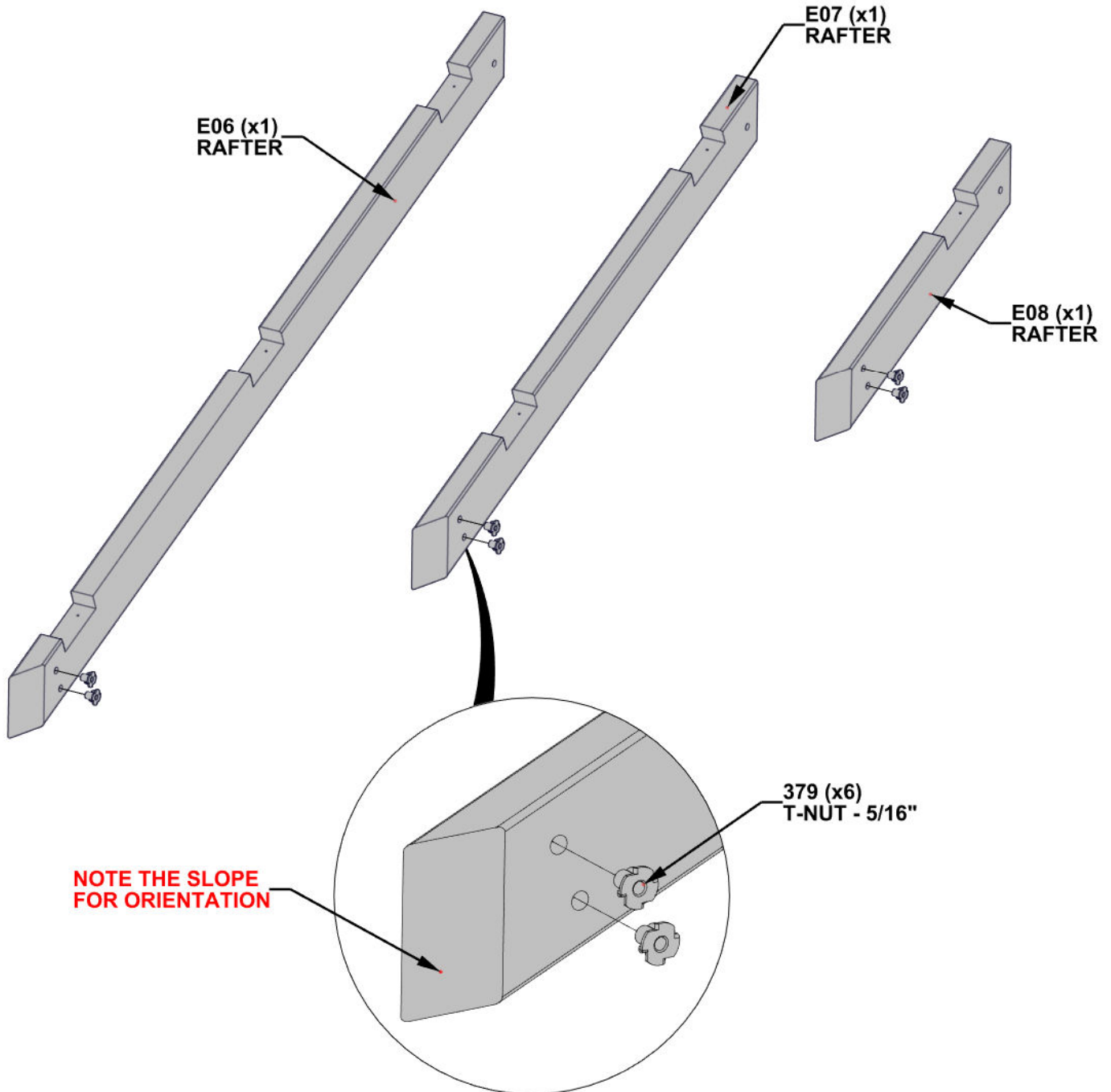

STEP 39B - ROOF ASSEMBLY

Qty	PartNo	Description
5	H100205	BOLT WH 5/16x2 1/4 BLK
6	H100407	BOLT WH 5/16x1 1/2 BLK
5	H100479	NUT LOCK 5/16 BLK
5	H100770	WASHER FLAT 5/16 BLK

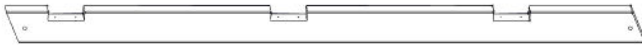

E03 RAFTER - W4L21717
 (x1) 1 7/16"x3 3/8"x62 1/4" (36x86x1579)

- WITH ONE EXTRA PERSON, ALIGN THE ONE THRU HOLE ENDS WITH RAFTER BRACKETS, ALIGN THE T-NUT ENDS WITH RAFTER TIES.
- ATTACH RAFTERS FROM CENTER TO OUTSIDE.

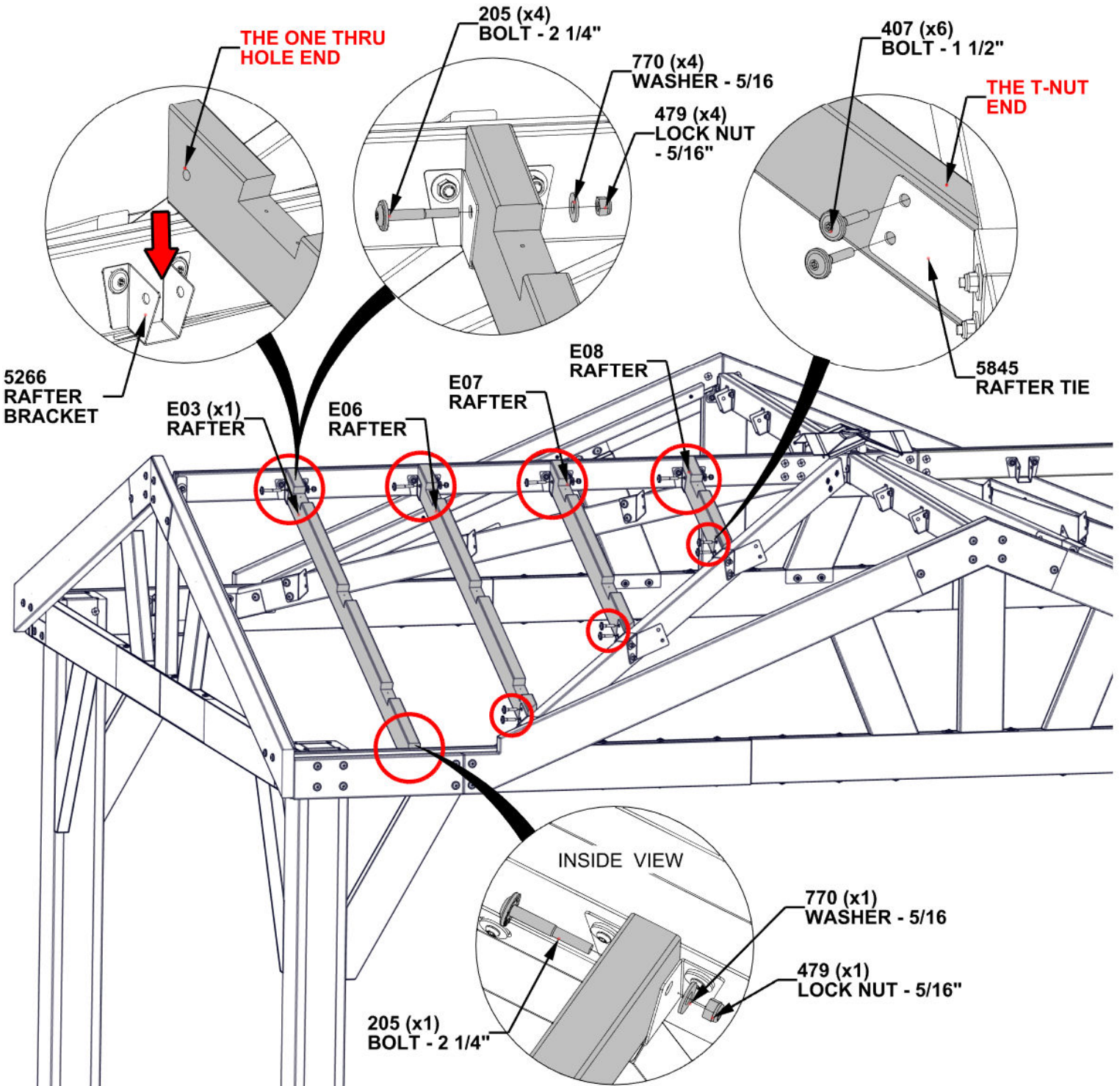

STEP 40A - ROOF ASSEMBLY

Qty	PartNo	Description
6	H100379	T-NUT 5/16 BLK

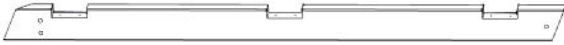

E09 RAFTER - W4L21723
(x1) 1 7/16"x3 3/8"x56 9/16" (36x86x1432)



E10 RAFTER - W4L21724
(x1) 1 7/16"x3 3/8"x39 3/16" (36x86x992)



E11 RAFTER - W4L21725
(x1) 1 7/16"x3 3/8"x21 7/8" (36x86x552)

- INSERT T-NUTS FIRST.

- FOR EASE OF ASSEMBLY, WE RECOMMEND USING SAW HORSES FOR THIS STEP.

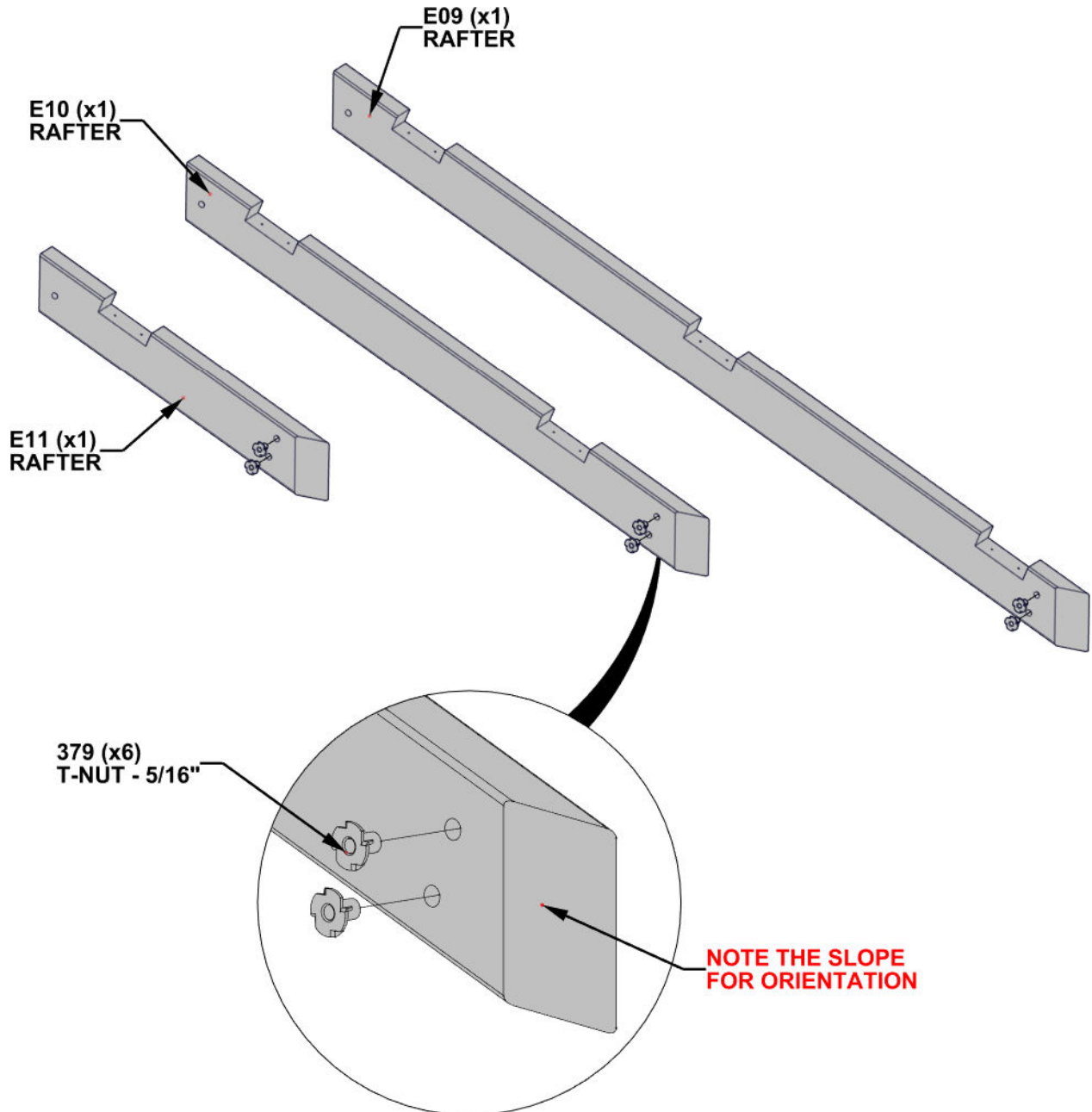

STEP 40B - ROOF ASSEMBLY

Qty	PartNo	Description
3	H100205	BOLT WH 5/16x2 1/4 BLK
6	H100407	BOLT WH 5/16x1 1/2 BLK
3	H100479	NUT LOCK 5/16 BLK
3	H100770	WASHER FLAT 5/16 BLK

- WITH ONE EXTRA PERSON, ALIGN THE ONE THRU HOLE ENDS WITH RAFTER BRACKETS, ALIGN THE T-NUT ENDS WITH RAFTER TIES.
- ATTACH RAFTERS FROM CENTER TO OUTSIDE.

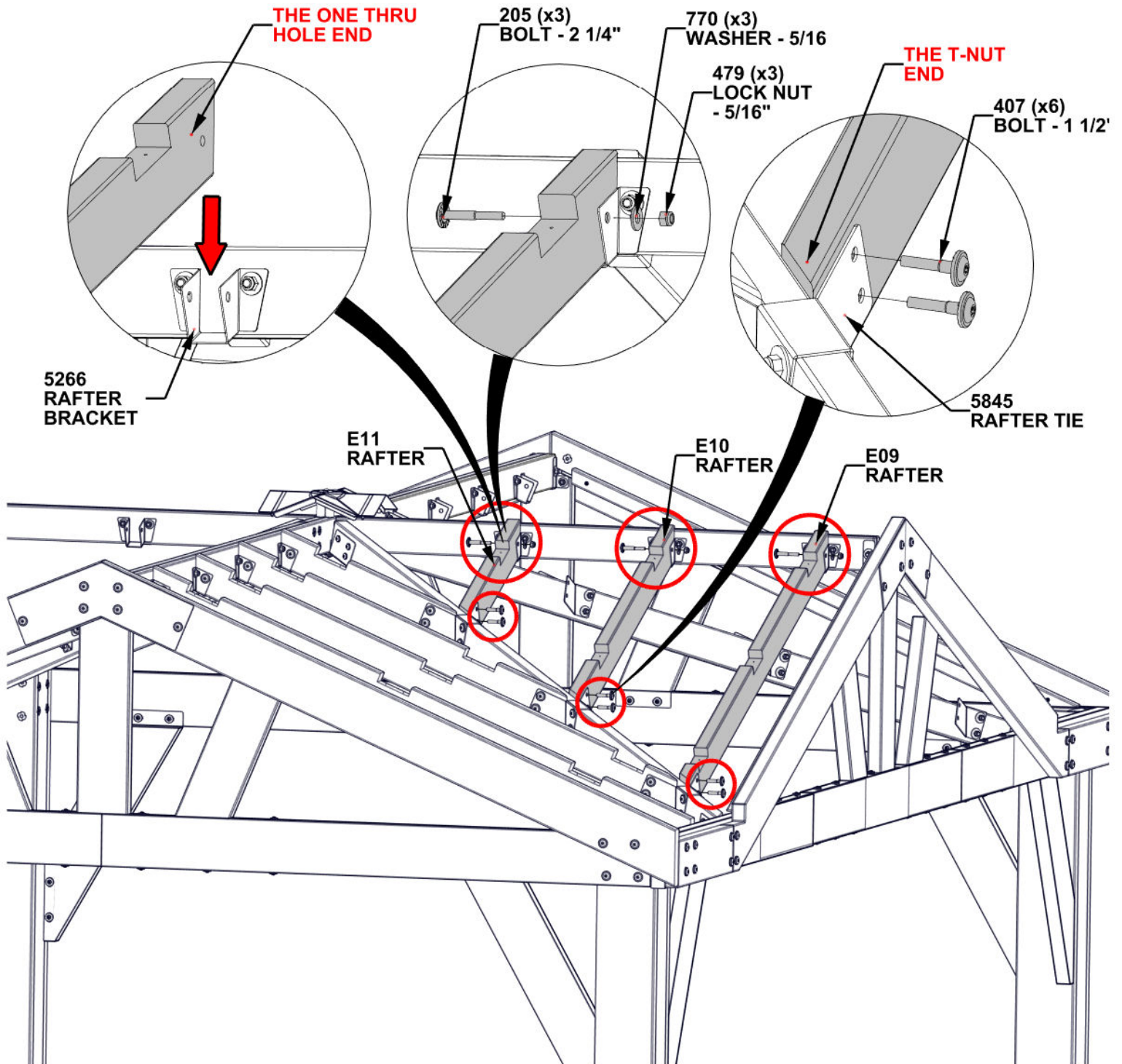

STEP 41A - ROOF ASSEMBLY

Qty	PartNo	Description
6	H100379	T-NUT 5/16 BLK

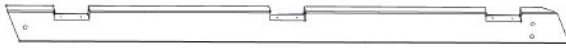

E12 RAFTER - W4L21726
(x1) 1 7/16"x3 3/8"x56 9/16" (36x86x1432)



E13 RAFTER - W4L21727
(x1) 1 7/16"x3 3/8"x39 3/16" (36x86x992)



E14 RAFTER - W4L21728
(x1) 1 7/16"x3 3/8"x21 7/8" (36x86x552)

- INSERT T-NUTS FIRST.

- FOR EASE OF ASSEMBLY, WE RECOMMEND USING SAW HORSES FOR THIS STEP.

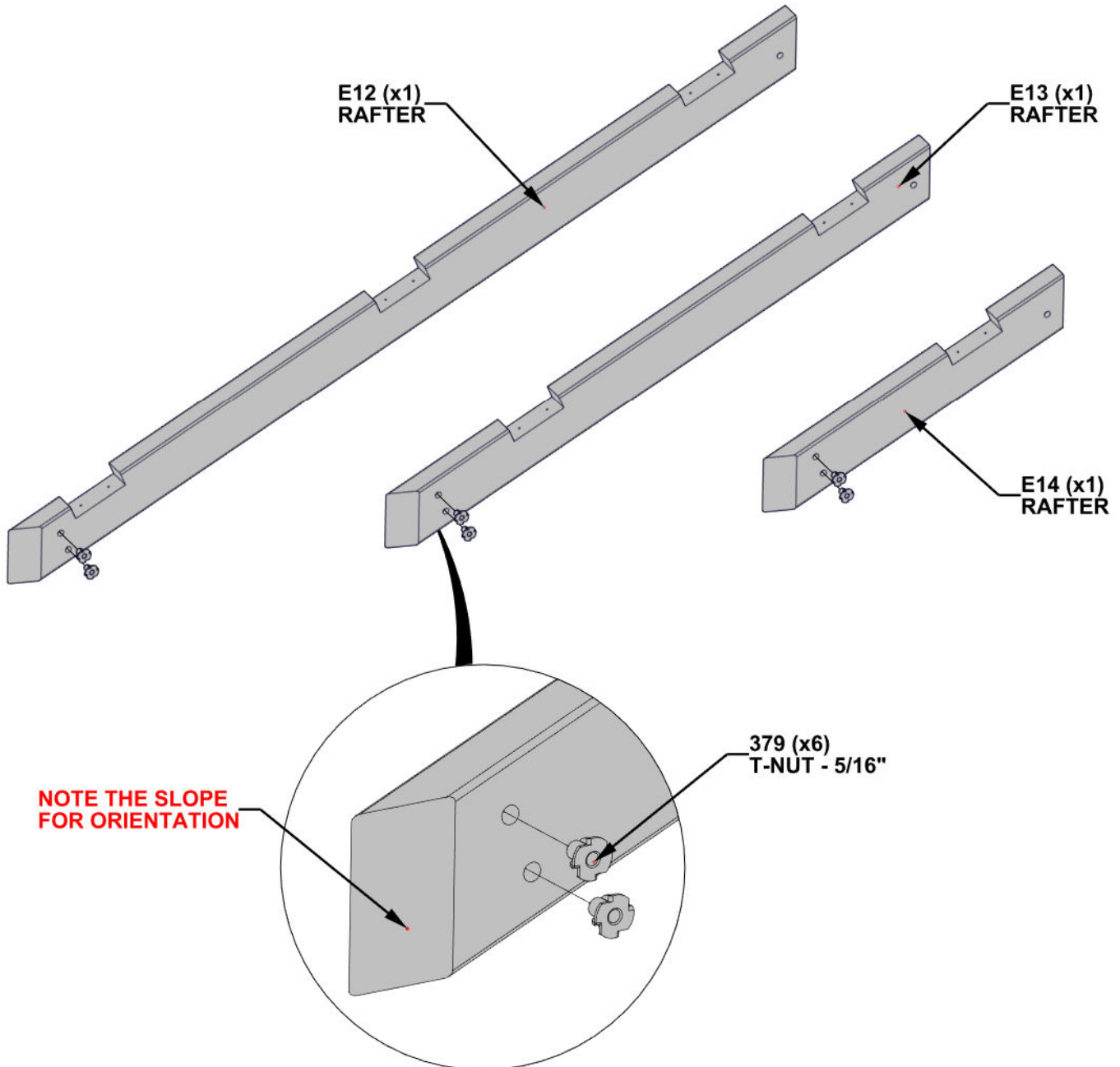

STEP 41B - ROOF ASSEMBLY

Qty	PartNo	Description
3	H100205	BOLT WH 5/16x2 1/4 BLK
6	H100407	BOLT WH 5/16x1 1/2 BLK
3	H100479	NUT LOCK 5/16 BLK
3	H100770	WASHER FLAT 5/16 BLK

- WITH ONE EXTRA PERSON, ALIGN THE ONE THRU HOLE ENDS WITH RAFTER BRACKETS, ALIGN THE T-NUT ENDS WITH RAFTER TIES.
- ATTACH RAFTERS FROM CENTER TO OUTSIDE.

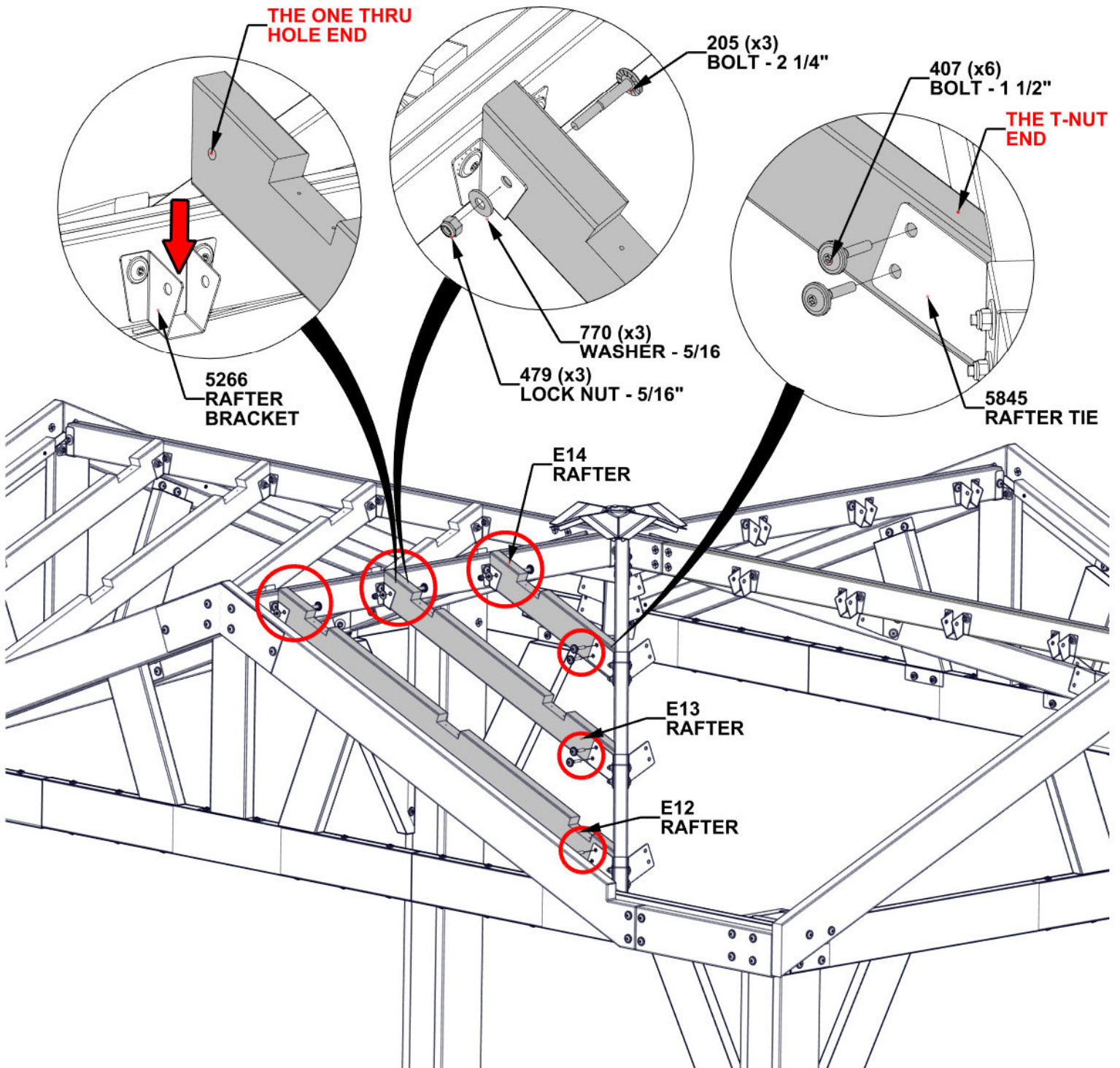

STEP 42A - ROOF ASSEMBLY

Qty	PartNo	Description
6	H100379	T-NUT 5/16 BLK



E02 RAFTER - W4L21716
(x1) 1 7/16"x3 3/8"x55 7/8" (36x86x1415)



E04 RAFTER - W4L21718
(x1) 1 7/16"x3 3/8"x38 9/16" (36x86x976)



E05 RAFTER - W4L21719
(x1) 1 7/16"x3 3/8"x21 1/4" (36x86x536)

- INSERT T-NUTS FIRST.

- FOR EASE OF ASSEMBLY, WE RECOMMEND USING SAW HORSES FOR THIS STEP.

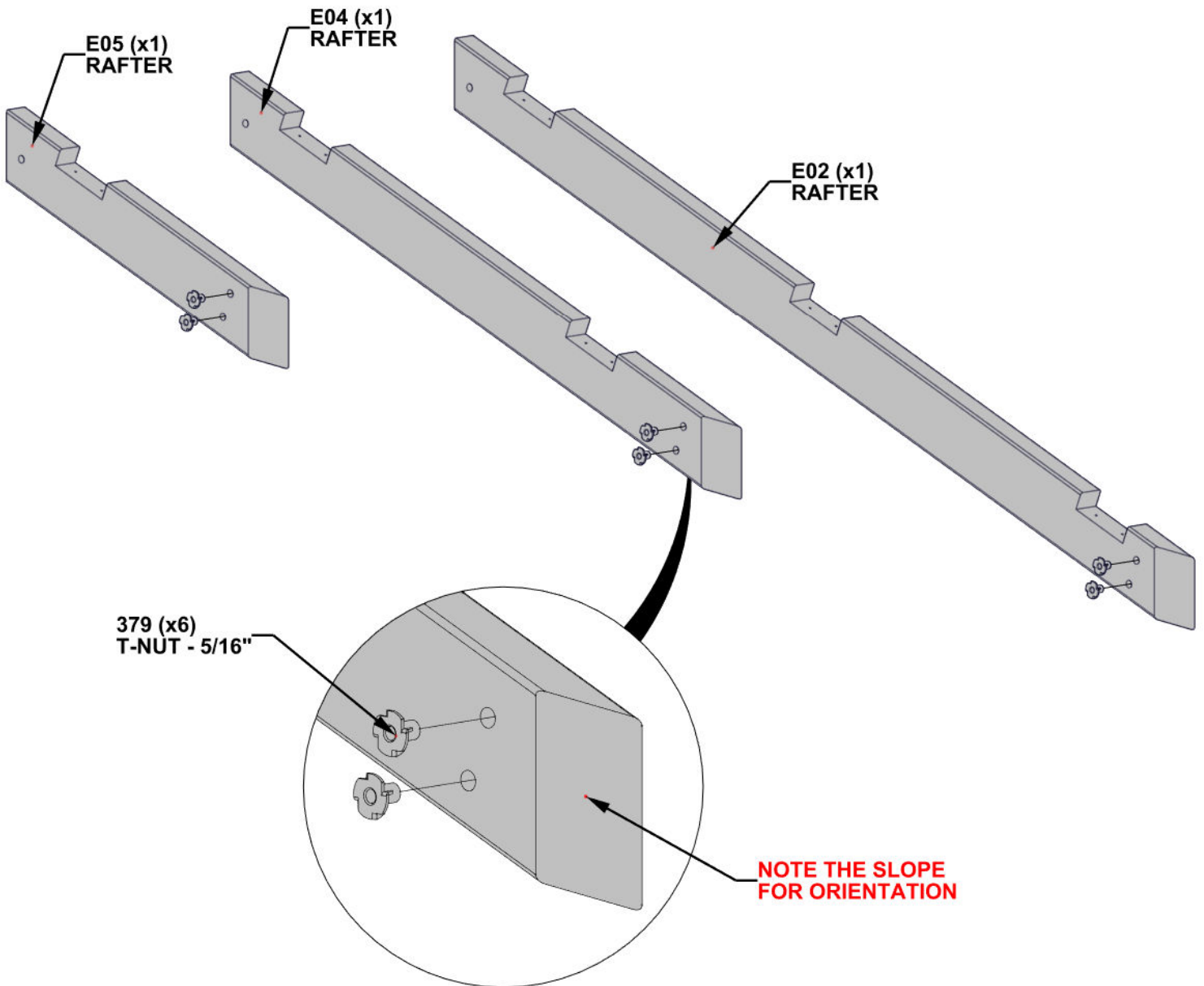

STEP 42B - ROOF ASSEMBLY

Qty	PartNo	Description
5	H100205	BOLT WH 5/16x2 1/4 BLK
6	H100407	BOLT WH 5/16x1 1/2 BLK
5	H100479	NUT LOCK 5/16 BLK
5	H100770	WASHER FLAT 5/16 BLK



E03 RAFTER - W4L21717
(x1) 1 7/16"x3 3/8"x62 1/4" (36x86x1579)

- WITH ONE EXTRA PERSON, ALIGN THE ONE THRU HOLE ENDS WITH RAFTER BRACKETS, ALIGN THE T-NUT ENDS WITH RAFTER TIES.
- ATTACH RAFTERS FROM CENTER TO OUTSIDE.

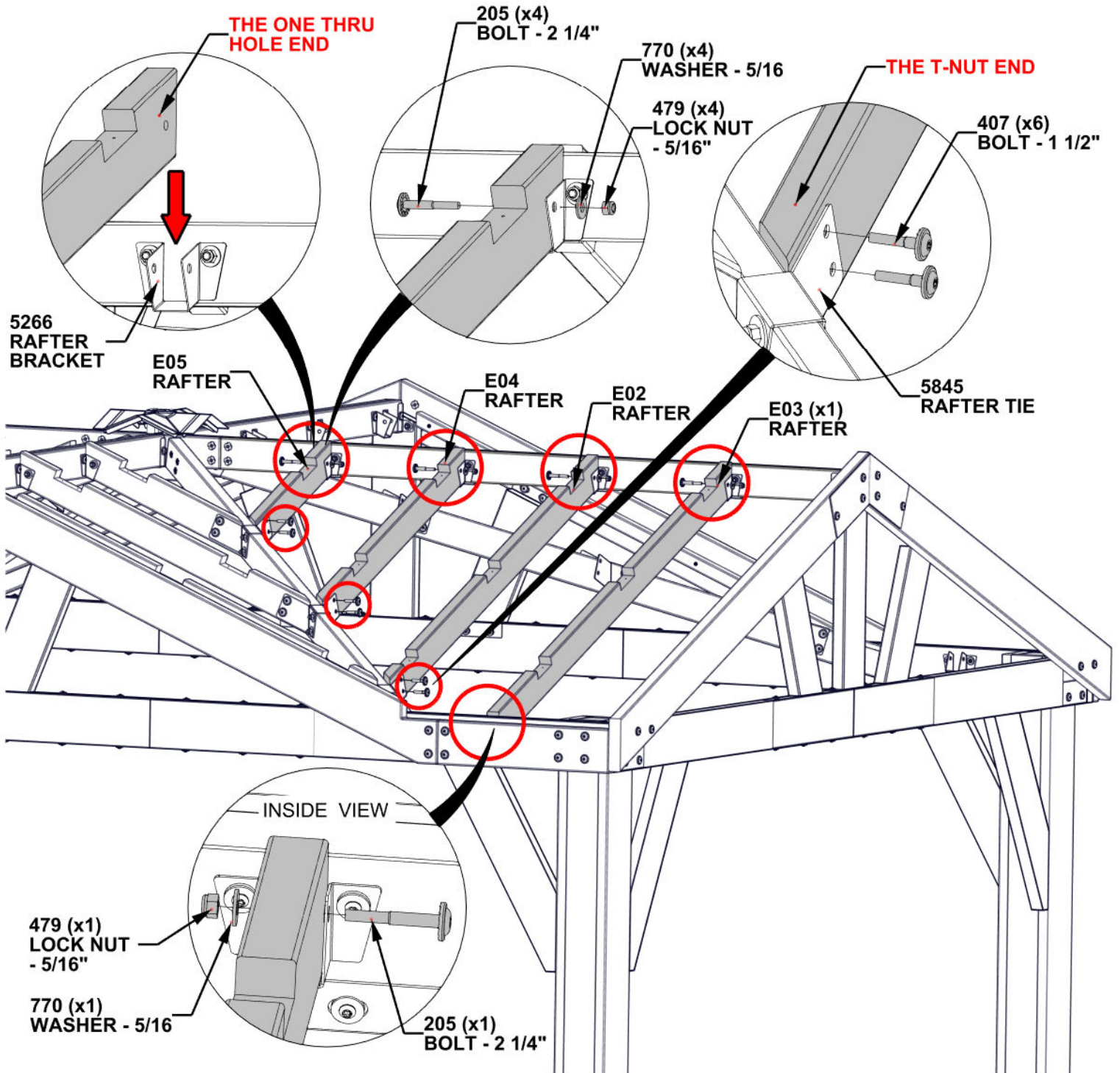

**REPEAT ROOF ASSEMBLY STEPS 39A - 42B
TO INSTALL RAFTER ON OPPOSITE SIDE OF ROOF**

STEP 43 - ROOF ASSEMBLY

Qty	PartNo	Description
24	H100391	SCREW PFH 8x2 BLK



H04 SHEATHING BOARD - W4L21713
(x1) 15/16"x3 3/8"x77" (24x86x1956)



H05 SHEATHING BOARD - W4L21714
(x1) 15/16"x3 3/8"x57 1/16" (24x86x1450)



H06 SHEATHING BOARD - W4L21715
(x1) 15/16"x3 3/8"x37" (24x86x940)

- WITH ONE EXTRA PERSON, ALIGN PILOT HOLES AND ATTACH SHEATHING BOARDS TO RAFTERS.

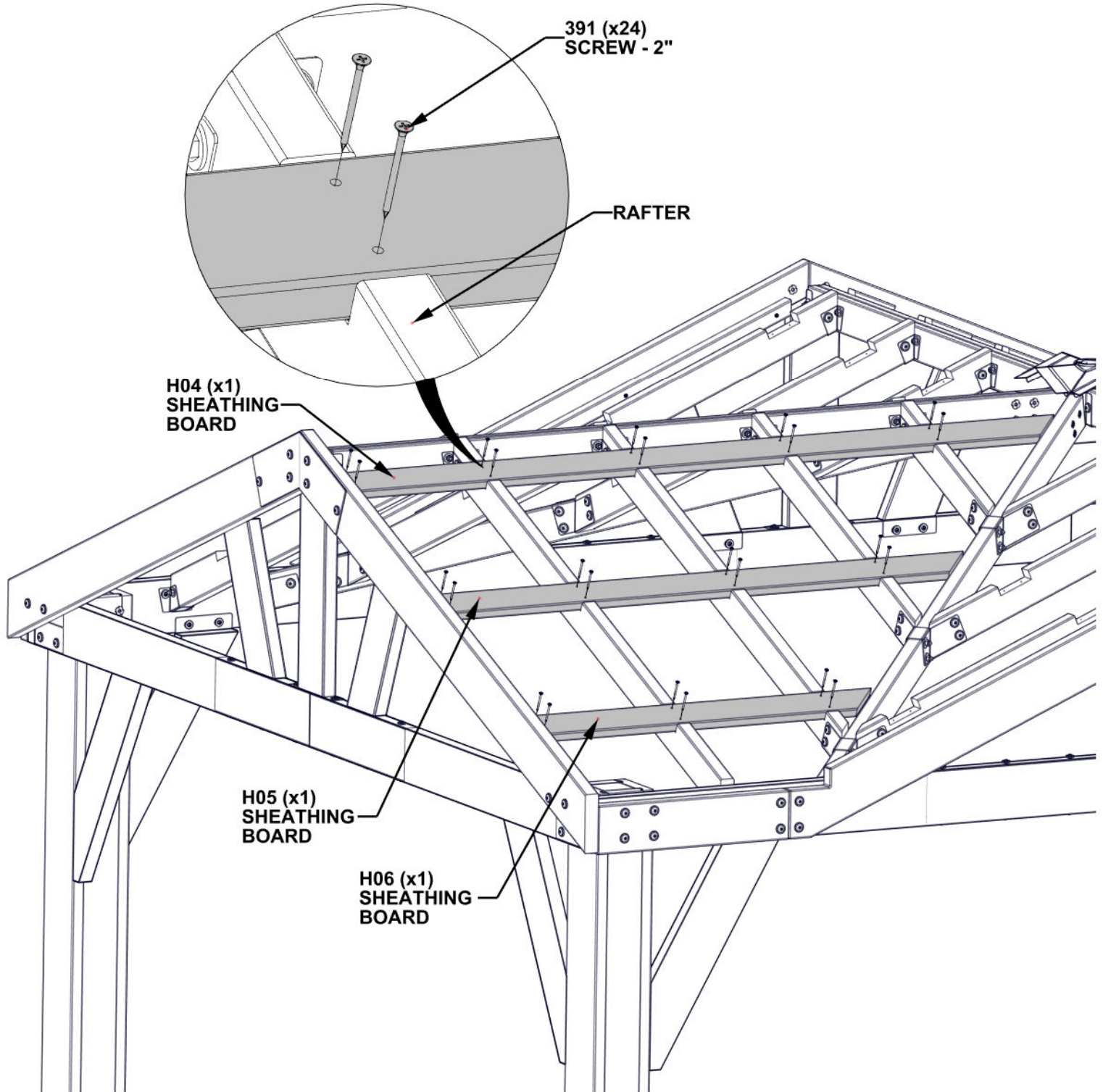

STEP 44 - ROOF ASSEMBLY

Qty	PartNo	Description
18	H100391	SCREW PFH 8x2 BLK



H07 SHEATHING BOARD - W4L21729
(x1) 15/16"x3 3/8"x52 11/16" (24x86x1339)



H08 SHEATHING BOARD - W4L21730
(x1) 15/16"x3 3/8"x32 3/4" (24x86x832)



H09 SHEATHING BOARD - W4L22265
(x1) 15/16"x3 3/8"x12 1/8" (24x86x325)

- WITH ONE EXTRA PERSON, ALIGN PILOT HOLES AND ATTACH SHEATHING BOARDS TO RAFTERS.

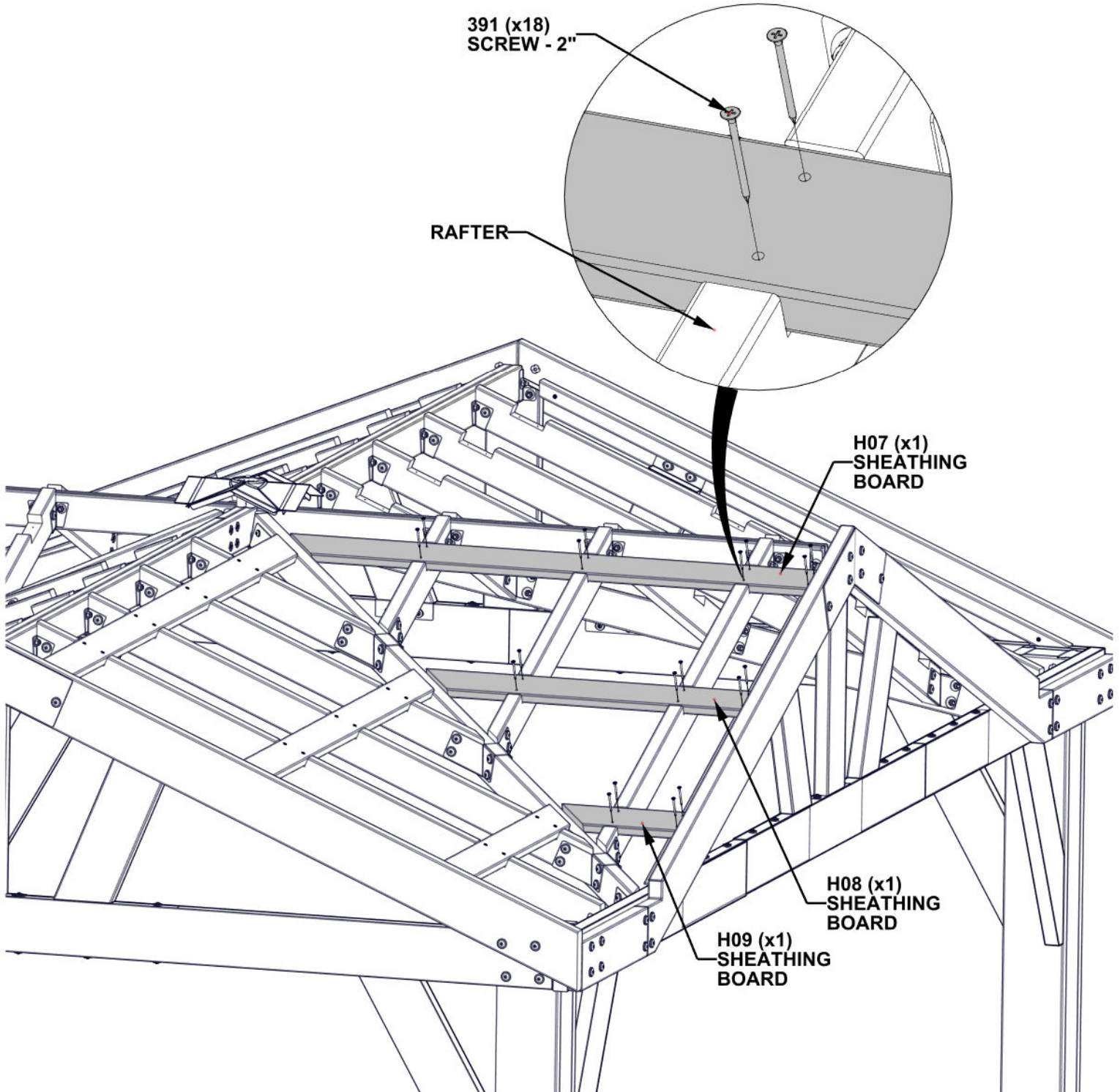

STEP 45 - ROOF ASSEMBLY

Qty	PartNo	Description
18	H100391	SCREW PFH 8x2 BLK



H07 SHEATHING BOARD - W4L21729
(x1) 15/16"x3 3/8"x52 11/16" (24x86x1339)



H08 SHEATHING BOARD - W4L21730
(x1) 15/16"x3 3/8"x32 3/4" (24x86x832)



H09 SHEATHING BOARD - W4L22265
(x1) 15/16"x3 3/8"x12 1/8" (24x86x325)

- WITH ONE EXTRA PERSON, ALIGN PILOT HOLES AND ATTACH SHEATHING BOARDS TO RAFTERS.

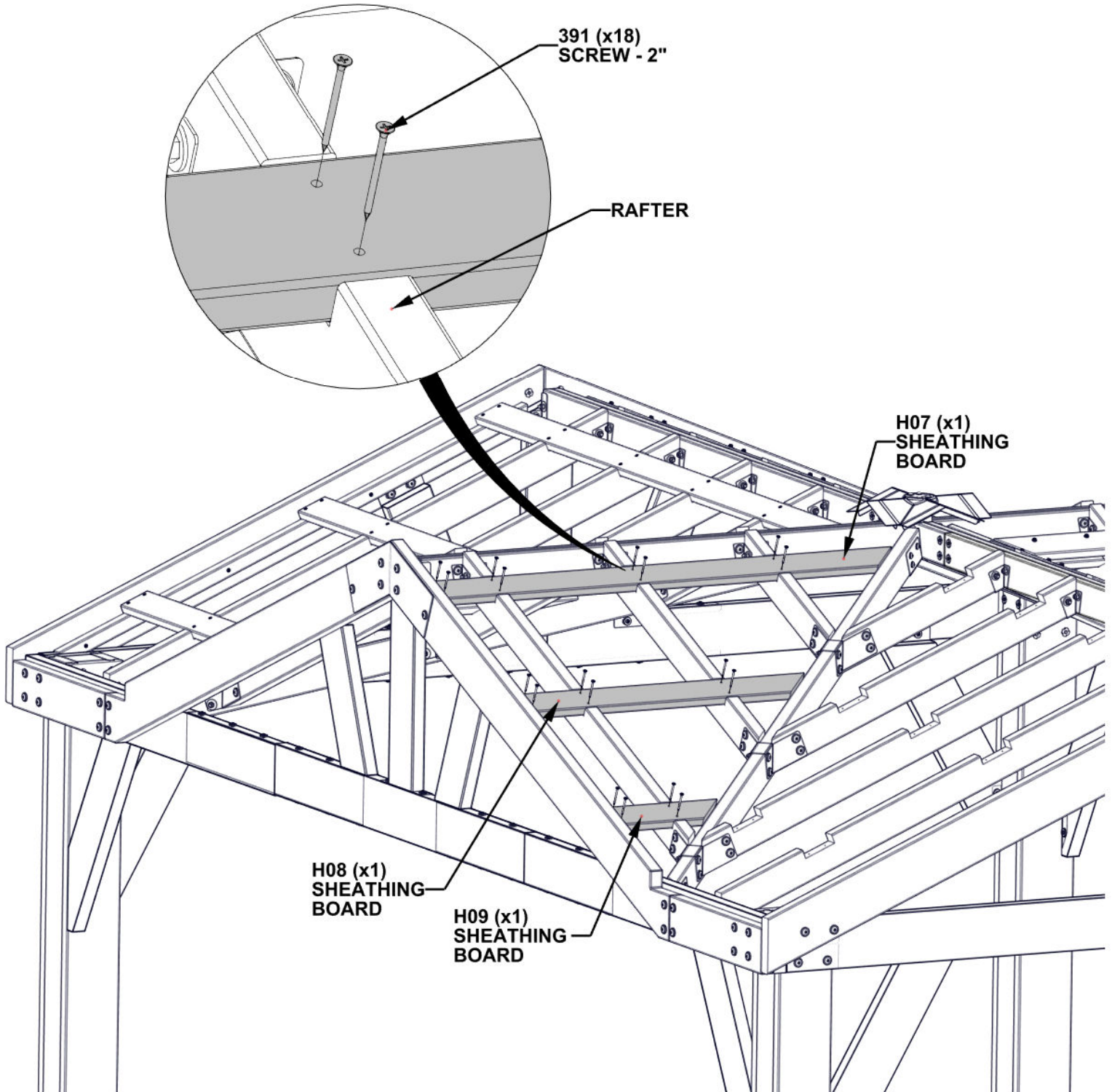

STEP 46 - ROOF ASSEMBLY

Qty	PartNo	Description
24	H100391	CREW PFH 8x2 BLK



H04 SHEATHING BOARD - W4L21713
(x1) 15/16"x3 3/8"x77" (24x86x1956)



H05 SHEATHING BOARD - W4L21714
(x1) 15/16"x3 3/8"x57 1/16" (24x86x1450)



H06 SHEATHING BOARD - W4L21715
(x1) 15/16"x3 3/8"x37" (24x86x940)

- WITH ONE EXTRA PERSON, ALIGN PILOT HOLES AND ATTACH SHEATHING BOARDS TO RAFTERS.

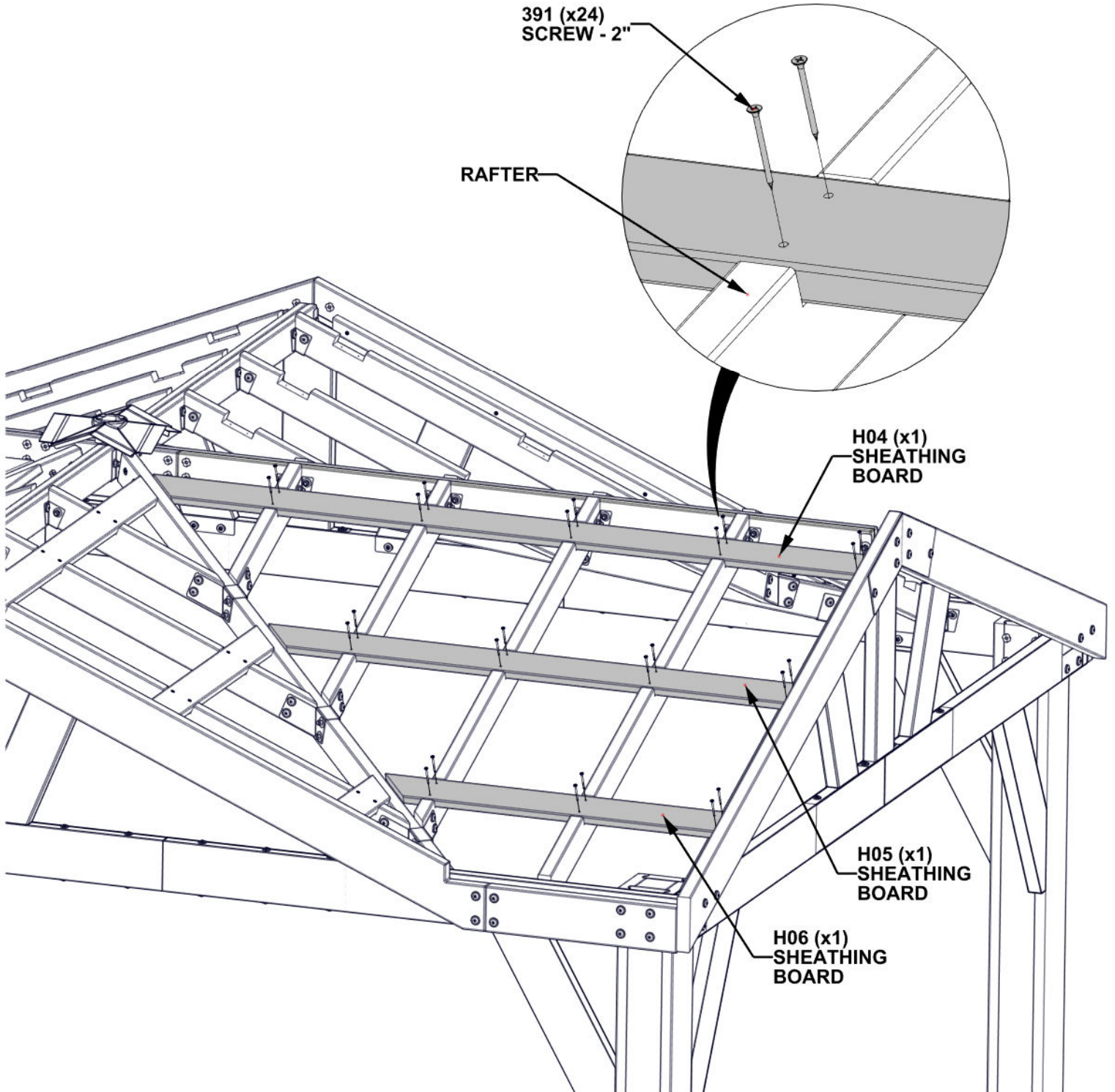

**REPEAT ROOF ASSEMBLY STEPS 43 - 46
TO INSTALL SHEATHING BOARD ON OPPOSITE SIDE OF ROOF**

STEP 47 - ROOF ASSEMBLY

Qty	PartNo	Description
6	H101117	SCREW WOODGRIP 10-16x3/4" BLK

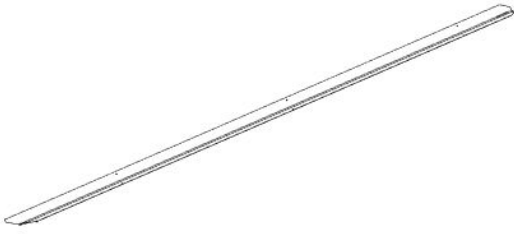

A4M05848 VALLEY FLASHING
(x1)

- REMOVE PROTECTIVE FILM.
- SLIDE VALLEY FLASHING UNDER THE RIDGE CAP SPLICE, ATTACH SCREWS AND TIGHTEN ALL HARDWARE.
- **WARNING: GLOVES ARE RECOMMENDED WHEN HANDLING STEEL ROOF PIECES.**

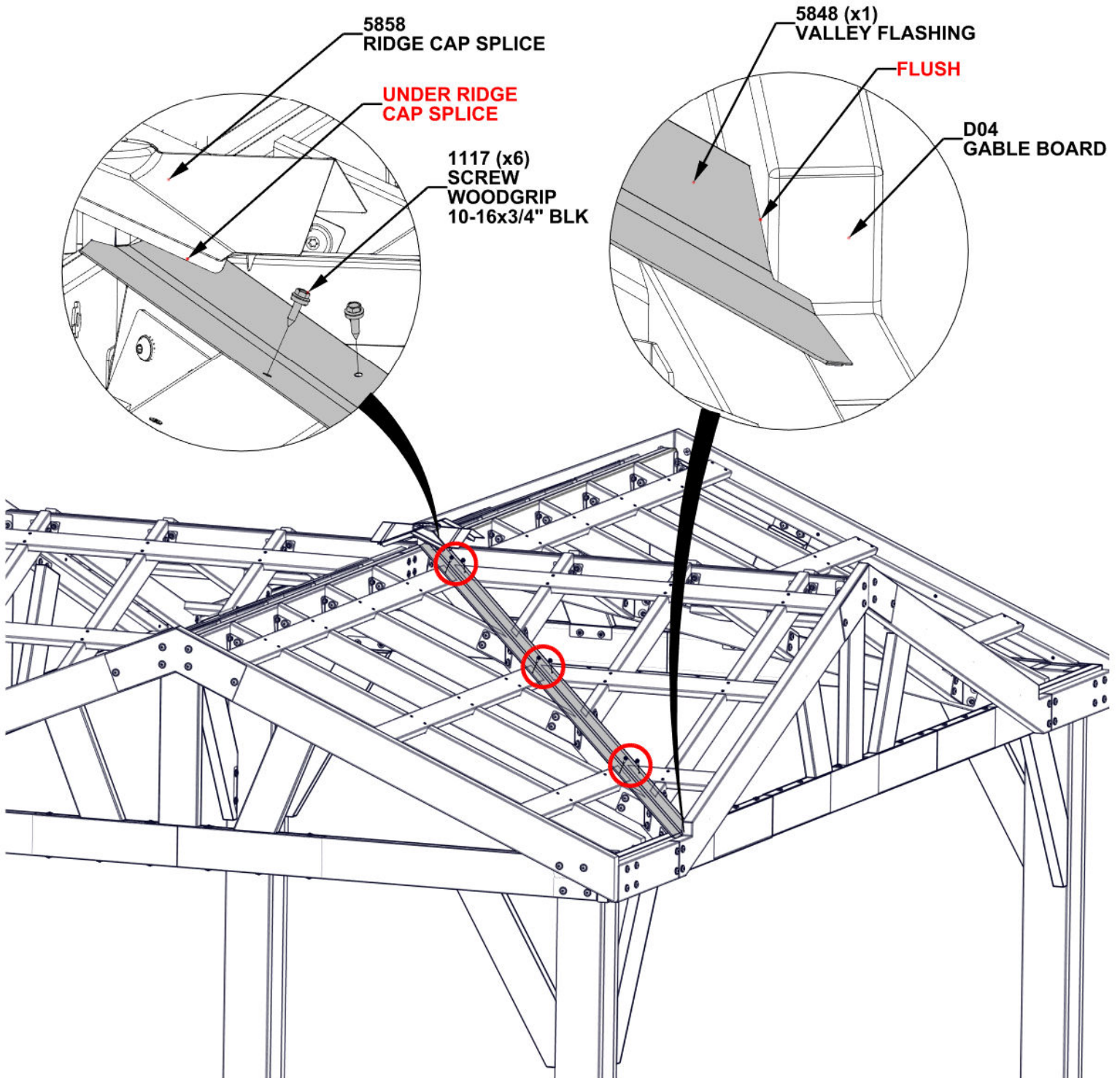

STEP 48A - ROOF ASSEMBLY

Qty	PartNo	Description
2	H101117	SCREW WOODGRIP 10-16x3/4" BLK

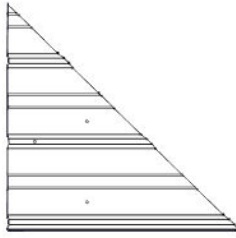

A4M05907-2 29 GA STEEL SHEETING
(x1)

- REMOVE PROTECTIVE FILM.
- SLIDE SHEET UNDER THE RIDGE CAP SPLICE, MAKING SURE THE LOWER END IS ON THE GROOVE OF VALLEY FLASHING.
- ATTACH SCREWS AND TIGHTEN ALL HARDWARE.
- **WARNING: GLOVES ARE RECOMMENDED WHEN HANDLING STEEL ROOF PIECES.**

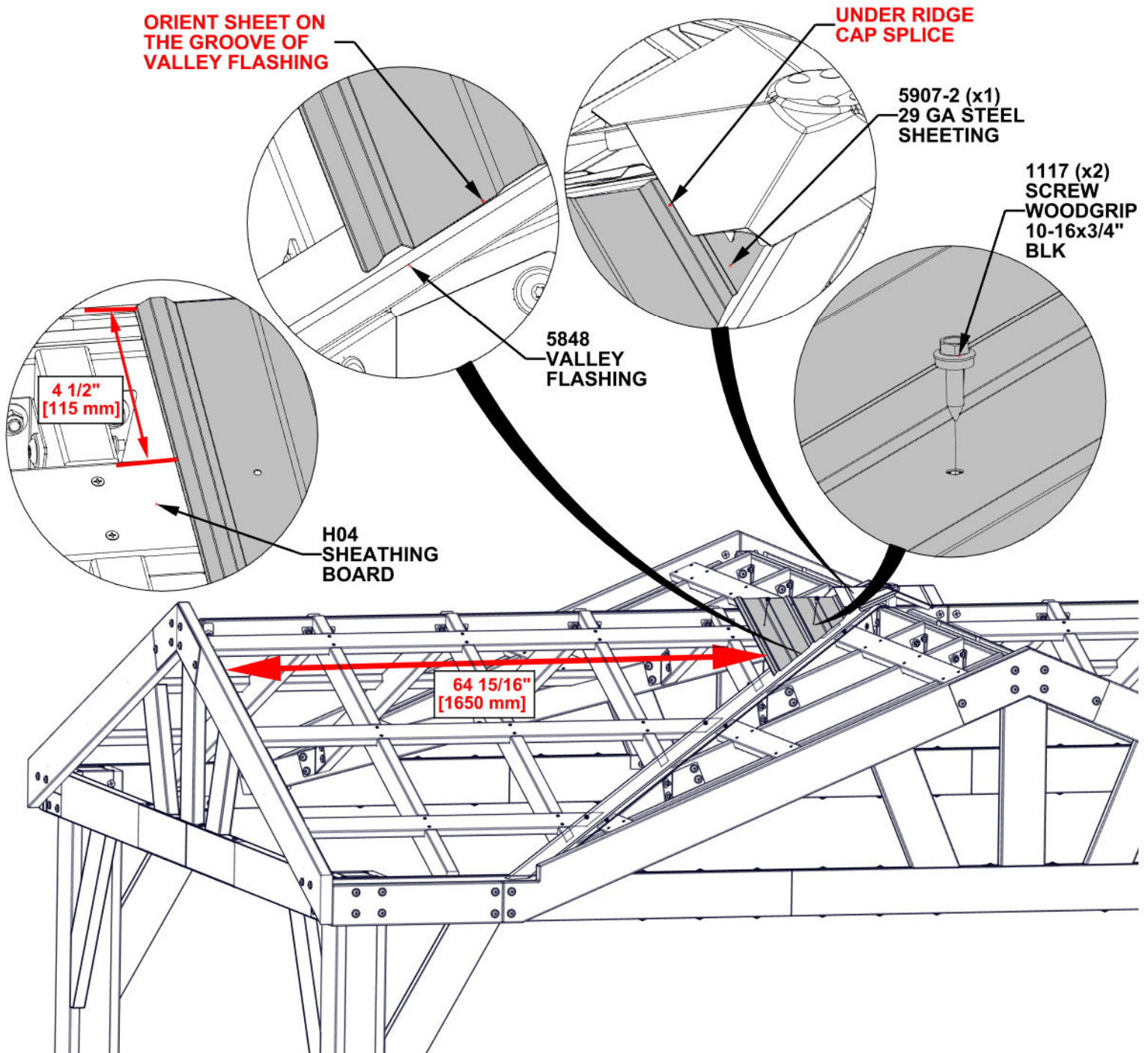

STEP 48B - ROOF ASSEMBLY

Qty	PartNo	Description
3	H101117	SCREW WOODGRIP 10-16x3/4" BLK

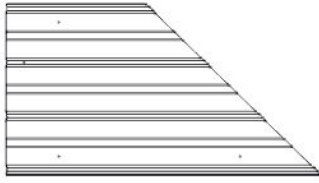

A4M05907-1 29 GA STEEL SHEETING
(x1)

- REMOVE PROTECTIVE FILM.
- SLIDE SHEET FROM OUTSIDE TO CENTER, MAKING SURE THE LOWER END IS ON THE GROOVE OF VALLEY FLASHING AND TOP OF SHEETS ARE FLUSH.
- ATTACH SCREWS AND TIGHTEN ALL HARDWARE.
- **WARNING: GLOVES ARE RECOMMENDED WHEN HANDLING STEEL ROOF PIECES.**

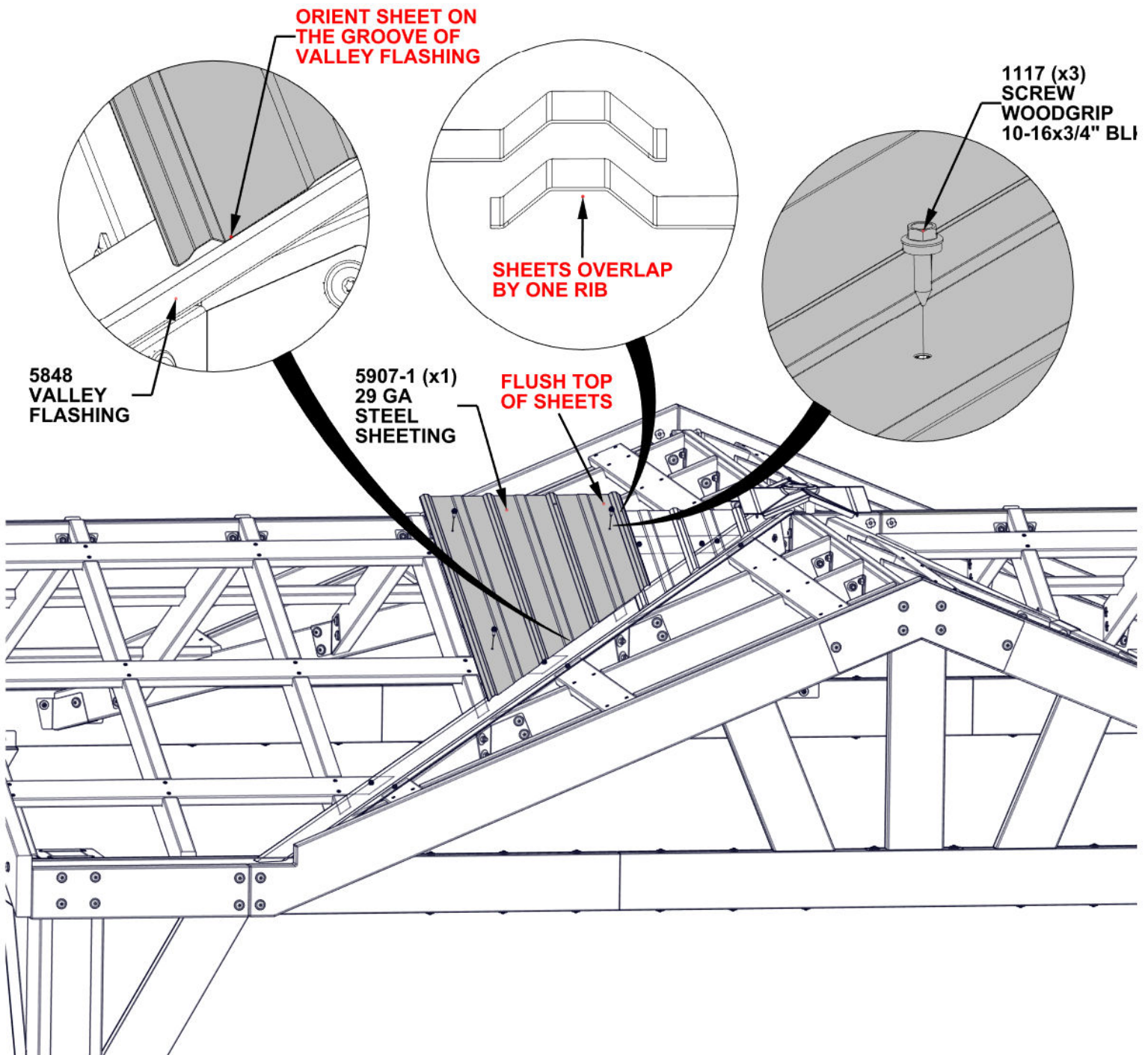

STEP 48C - ROOF ASSEMBLY

Qty	PartNo	Description
17	H101117	SCREW WOODGRIP 10-16x3/4" BLK



A4M05257 29 GA SHEETING (x1)



A4M05789 29 GA SHEETING (x1)

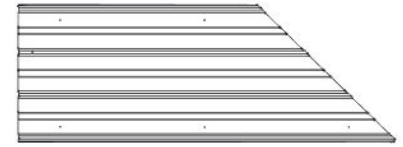

A4M05790 29 GA SHEETING (x1)

- REMOVE PROTECTIVE FILM.
- INSTALL THREE SHEETS IN THE SAME WAY AS THE PREVIOUS STEP.
- ATTACH AND FULLY TIGHTEN ALL SCREWS ON EACH ROOF SHEET BEFORE ATTACHING THE NEXT ONE. THIS MAKES IT POSSIBLE TO REACH ALL THE SCREWS WITHOUT GETTING ON THE ROOF.
- **WARNING: GLOVES ARE RECOMMENDED WHEN HANDLING STEEL ROOF PIECES.**

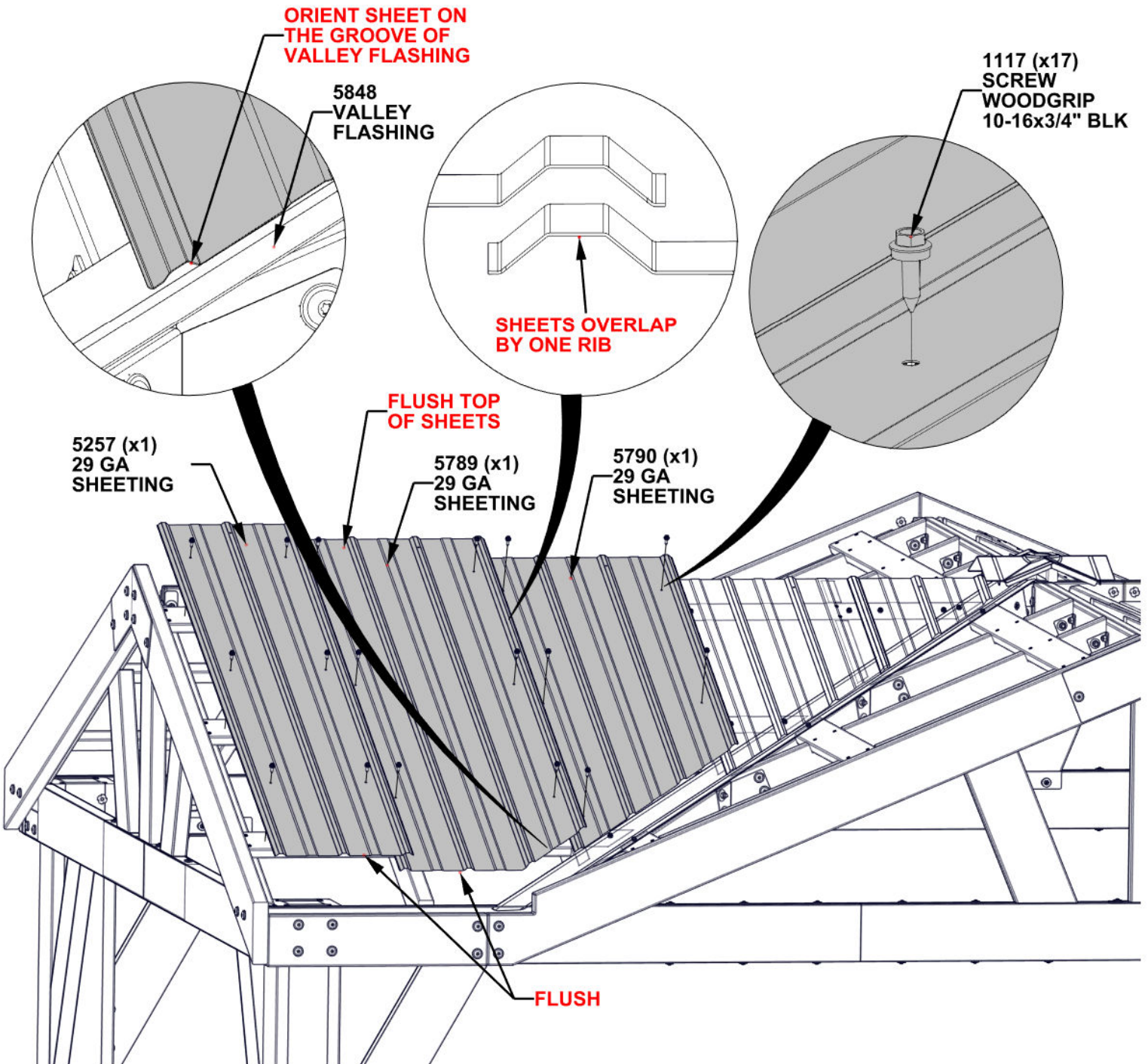

STEP 49A - ROOF ASSEMBLY

Qty	PartNo	Description
2	H101117	SCREW WOODGRIP 10-16x3/4" BLK

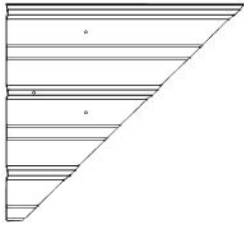

A4M05910-2 29 GA STEEL SHEETING
(x1)

- REMOVE PROTECTIVE FILM.
- SLIDE SHEET UNDER THE RIDGE CAP SPLICE, MAKING SURE THE LOWER END IS ON THE GROOVE OF VALLEY FLASHING.
- ATTACH SCREWS AND TIGHTEN ALL HARDWARE.
- **WARNING: GLOVES ARE RECOMMENDED WHEN HANDLING STEEL ROOF PIECES.**

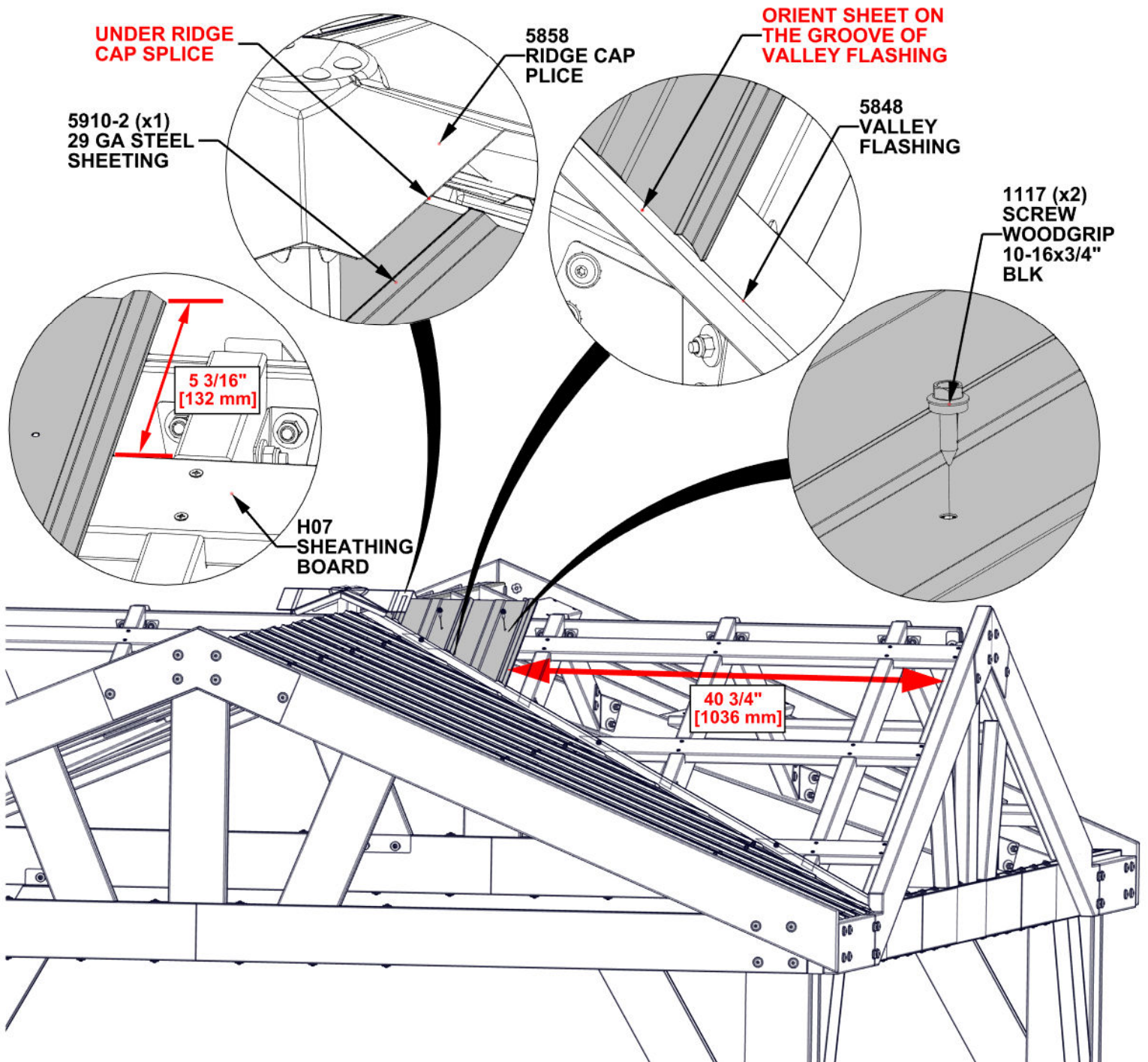

STEP 49B - ROOF ASSEMBLY

Qty	PartNo	Description
3	H101117	SCREW WOODGRIP 10-16x3/4" BLK

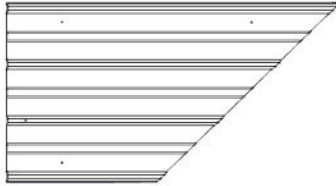

A4M05910-1 29 GA STEEL SHEETING
(x1)

- REMOVE PROTECTIVE FILM.
- SLIDE SHEET FROM OUTSIDE TO CENTER, MAKING SURE THE LOWER END IS ON THE GROOVE OF VALLEY FLASHING AND TOP OF SHEETS ARE FLUSH.
- ATTACH SCREWS AND TIGHTEN ALL HARDWARE.
- **WARNING: GLOVES ARE RECOMMENDED WHEN HANDLING STEEL ROOF PIECES.**

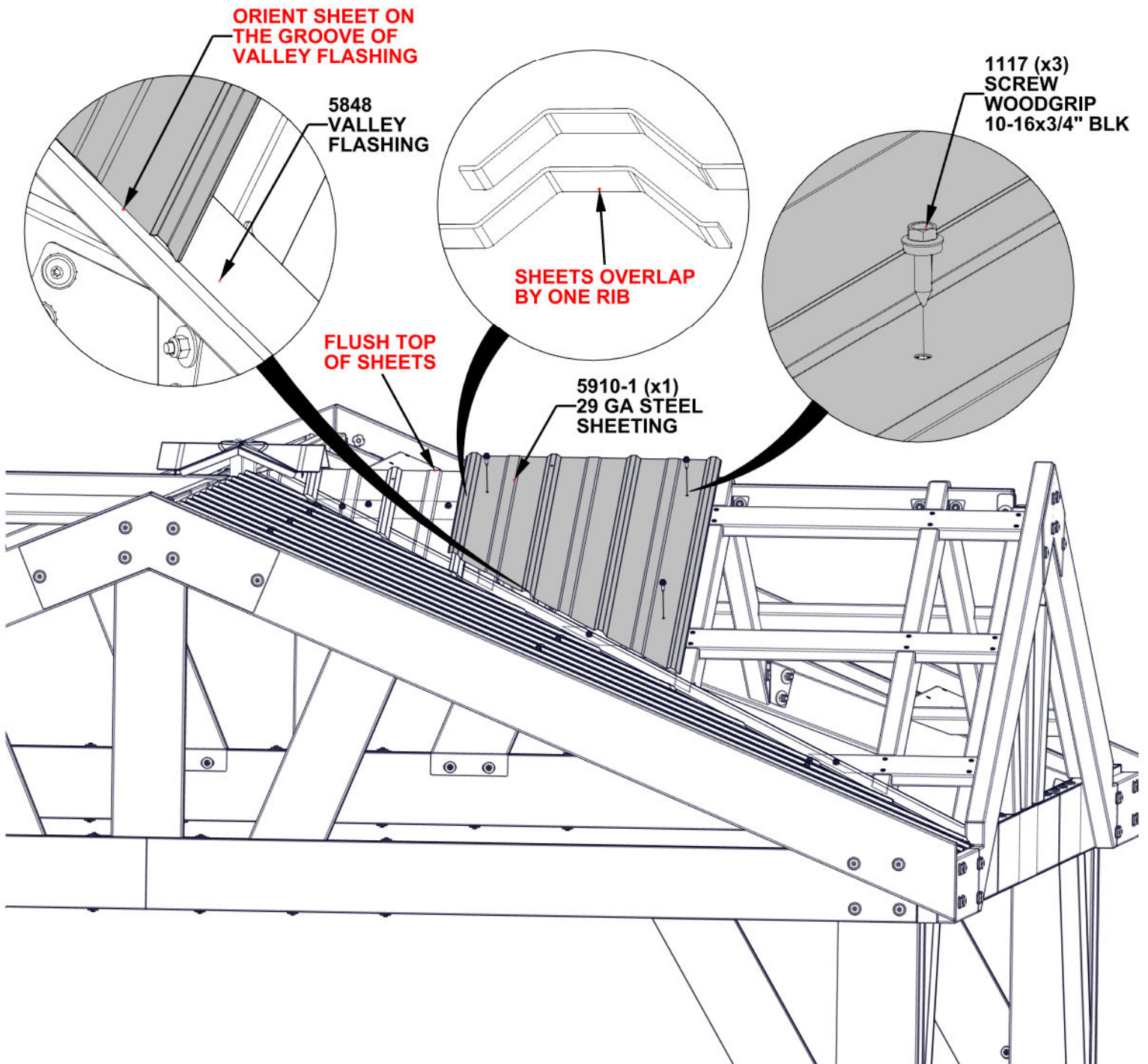

STEP 49C - ROOF ASSEMBLY

Qty	PartNo	Description
11	H101117	SCREW WOODGRIP 10-16x3/4" BLK



A4M05911-1 29 GA SHEETING
(x1)

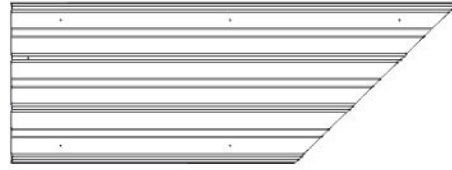

A4M05793 29 GA SHEETING
(x1)

- REMOVE PROTECTIVE FILM.
- INSTALL TWO SHEETS IN THE SAME WAY AS THE PREVIOUS STEP.
- ATTACH AND FULLY TIGHTEN ALL SCREWS ON EACH ROOF SHEET BEFORE ATTACHING THE NEXT ONE. THIS MAKES IT POSSIBLE TO REACH ALL THE SCREWS WITHOUT GETTING ON THE ROOF.
- **WARNING: GLOVES ARE RECOMMENDED WHEN HANDLING STEEL ROOF PIECES.**

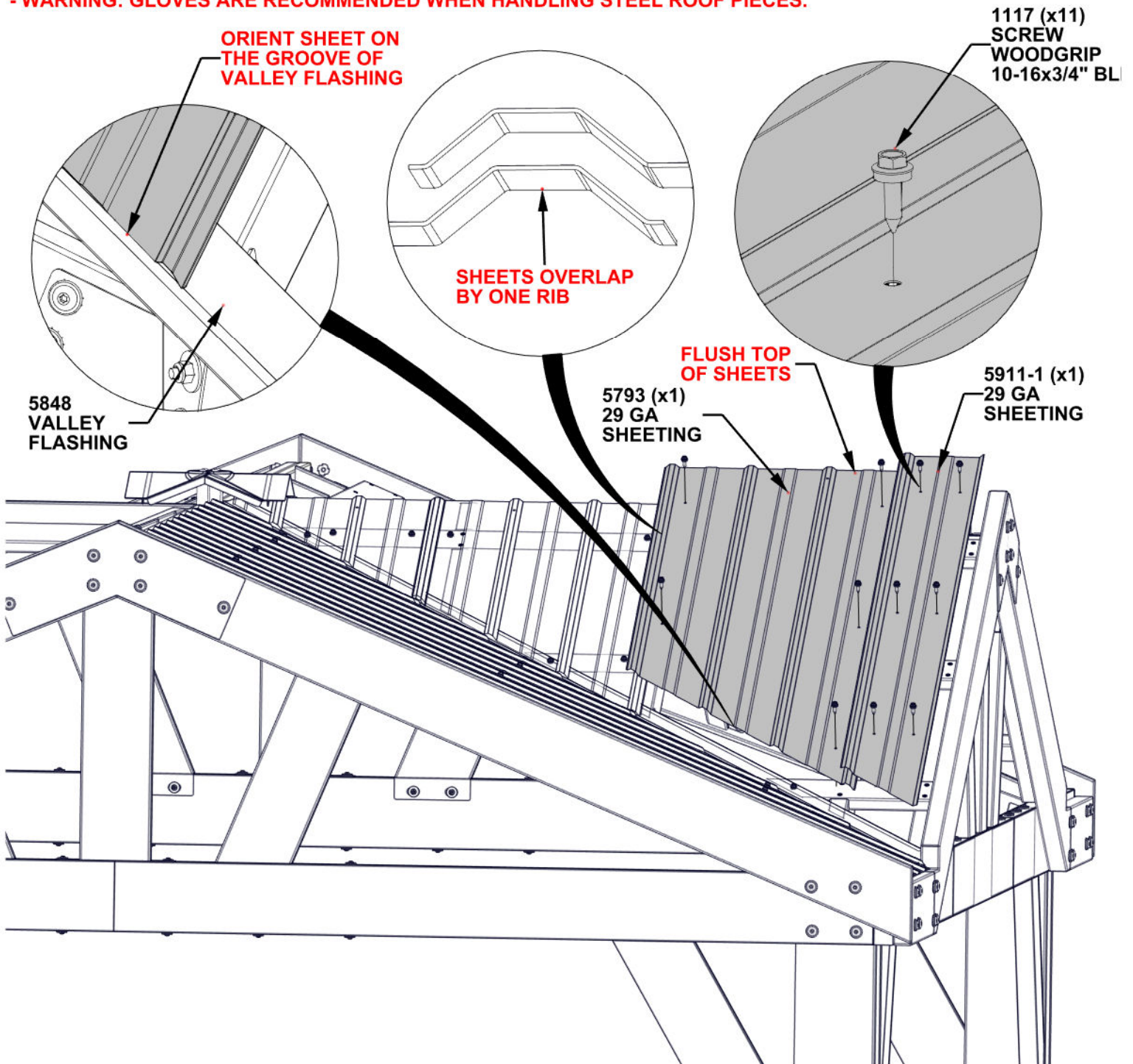

STEP 50 - ROOF ASSEMBLY

Qty	PartNo	Description
6	H101117	SCREW WOODGRIP 10-16x3/4" BLK

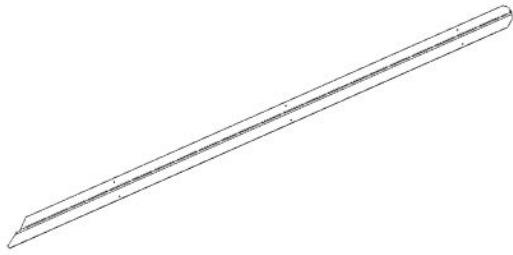

A4M05849 VALLEY FLASHING
(x1)

- REMOVE PROTECTIVE FILM.
- SLIDE VALLEY FLASHING UNDER THE RIDGE CAP SPLICE, ATTACH SCREWS AND TIGHTEN ALL HARDWARE.
- **WARNING: GLOVES ARE RECOMMENDED WHEN HANDLING STEEL ROOF PIECES.**

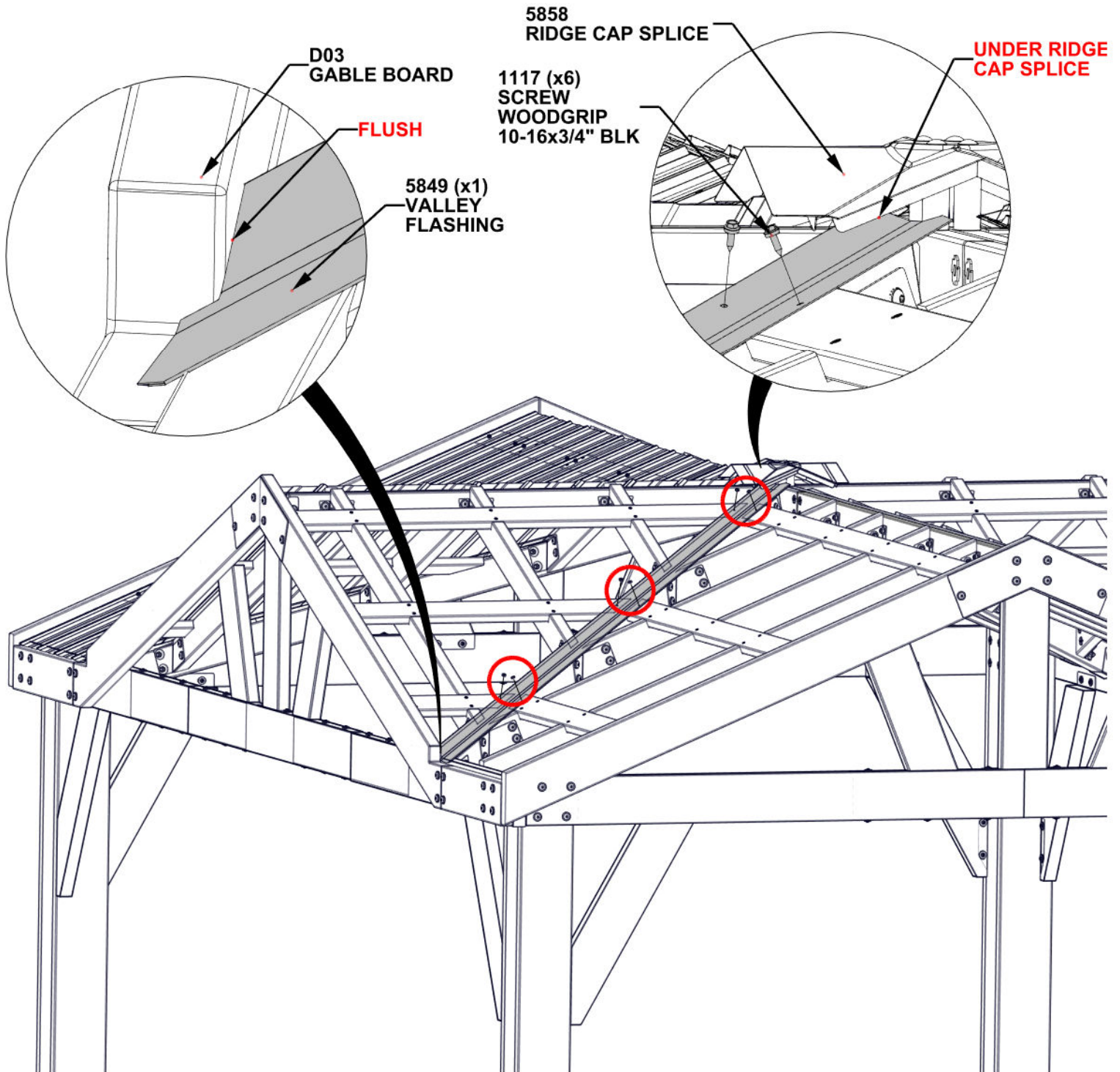

STEP 51A - ROOF ASSEMBLY

Qty	PartNo	Description
2	H101117	SCREW WOODGRIP 10-16x3/4" BLK

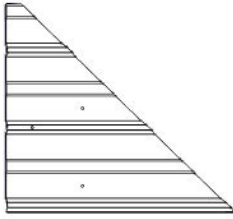

A4M05909-2 29 GA STEEL SHEETING
(x1)

- REMOVE PROTECTIVE FILM.
- SLIDE SHEET UNDER THE RIDGE CAP SPLICE, MAKING SURE THE LOWER END IS ON THE GROOVE OF VALLEY FLASHING.
- ATTACH SCREWS AND TIGHTEN ALL HARDWARE.
- **WARNING: GLOVES ARE RECOMMENDED WHEN HANDLING STEEL ROOF PIECES.**

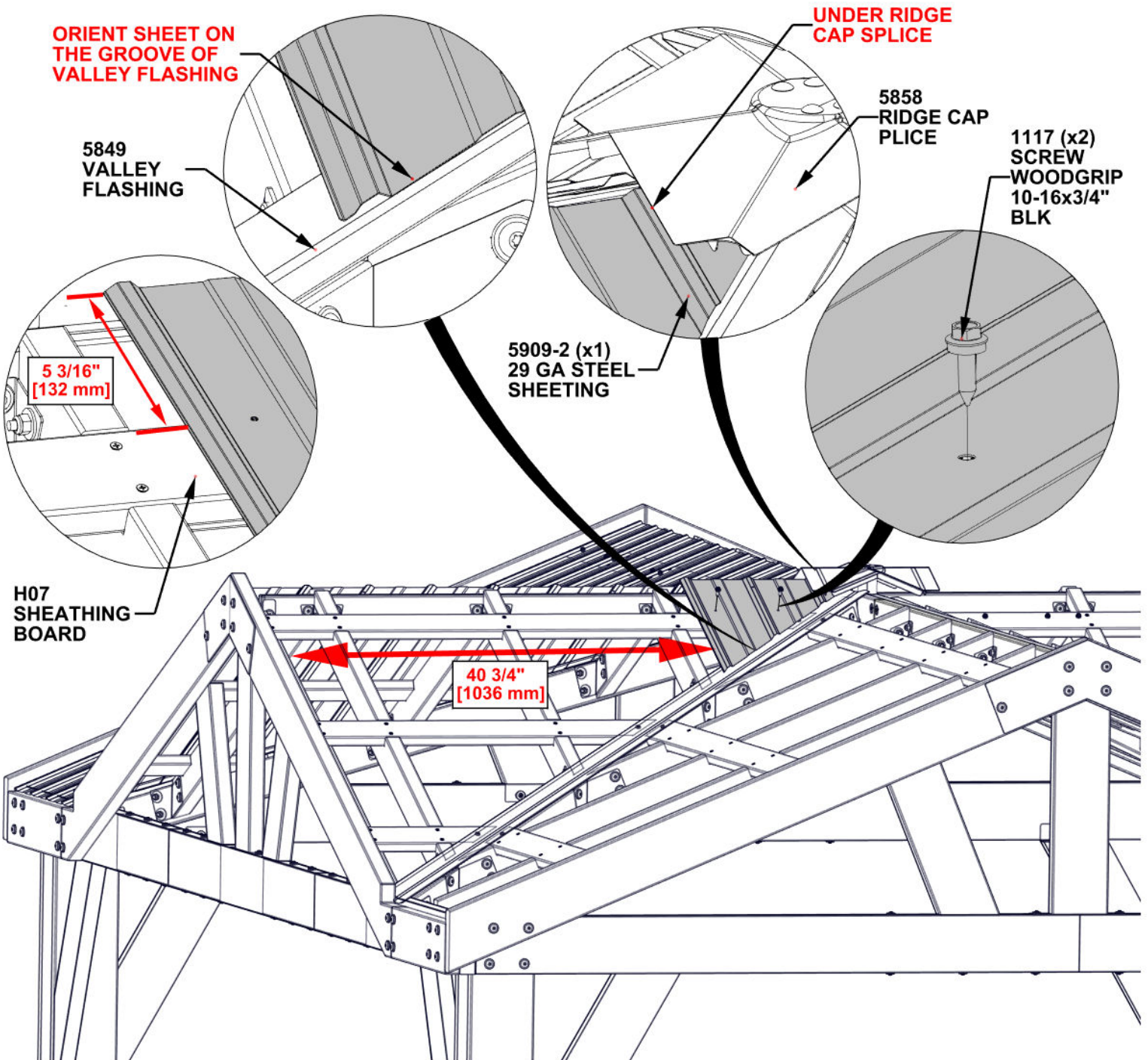

STEP 51B - ROOF ASSEMBLY

Qty	PartNo	Description
3	H101117	SCREW WOODGRIP 10-16x3/4" BLK

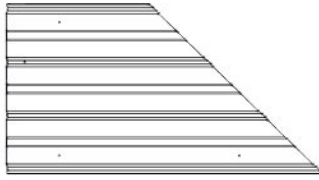

A4M05909-1 29 GA STEEL SHEETING
(x1)

- REMOVE PROTECTIVE FILM.
- SLIDE SHEET FROM OUTSIDE TO CENTER, MAKING SURE THE LOWER END IS ON THE GROOVE OF VALLEY FLASHING AND TOP OF SHEETS ARE FLUSH.
- ATTACH SCREWS AND TIGHTEN ALL HARDWARE.
- **WARNING: GLOVES ARE RECOMMENDED WHEN HANDLING STEEL ROOF PIECES.**

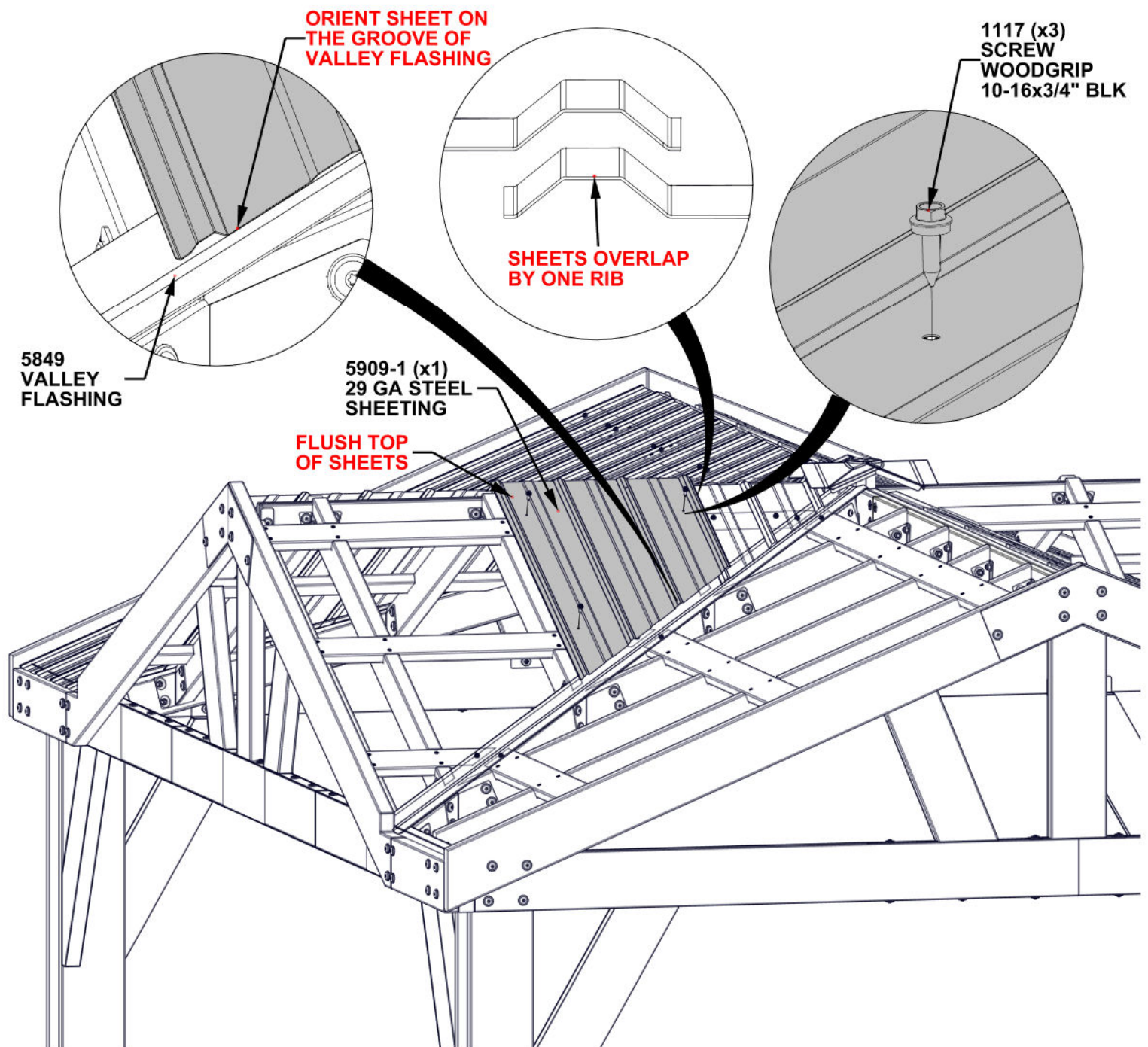

STEP 51C - ROOF ASSEMBLY

Qty	PartNo	Description
11	H101117	SCREW WOODGRIP 10-16x3/4" BLK

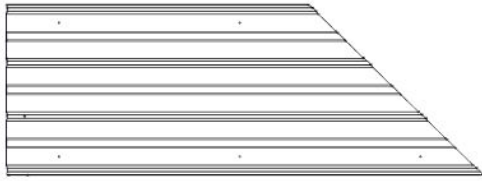

A4M05842 29 GA SHEETING
(x1)



A4M05911-2 29 GA SHEETING
(x1)

- REMOVE PROTECTIVE FILM.
- INSTALL TWO SHEETS IN THE SAME WAY AS THE PREVIOUS STEP.
- ATTACH AND FULLY TIGHTEN ALL SCREWS ON EACH ROOF SHEET BEFORE ATTACHING THE NEXT ONE. THIS MAKES IT POSSIBLE TO REACH ALL THE SCREWS WITHOUT GETTING ON THE ROOF.
- **WARNING: GLOVES ARE RECOMMENDED WHEN HANDLING STEEL ROOF PIECES.**

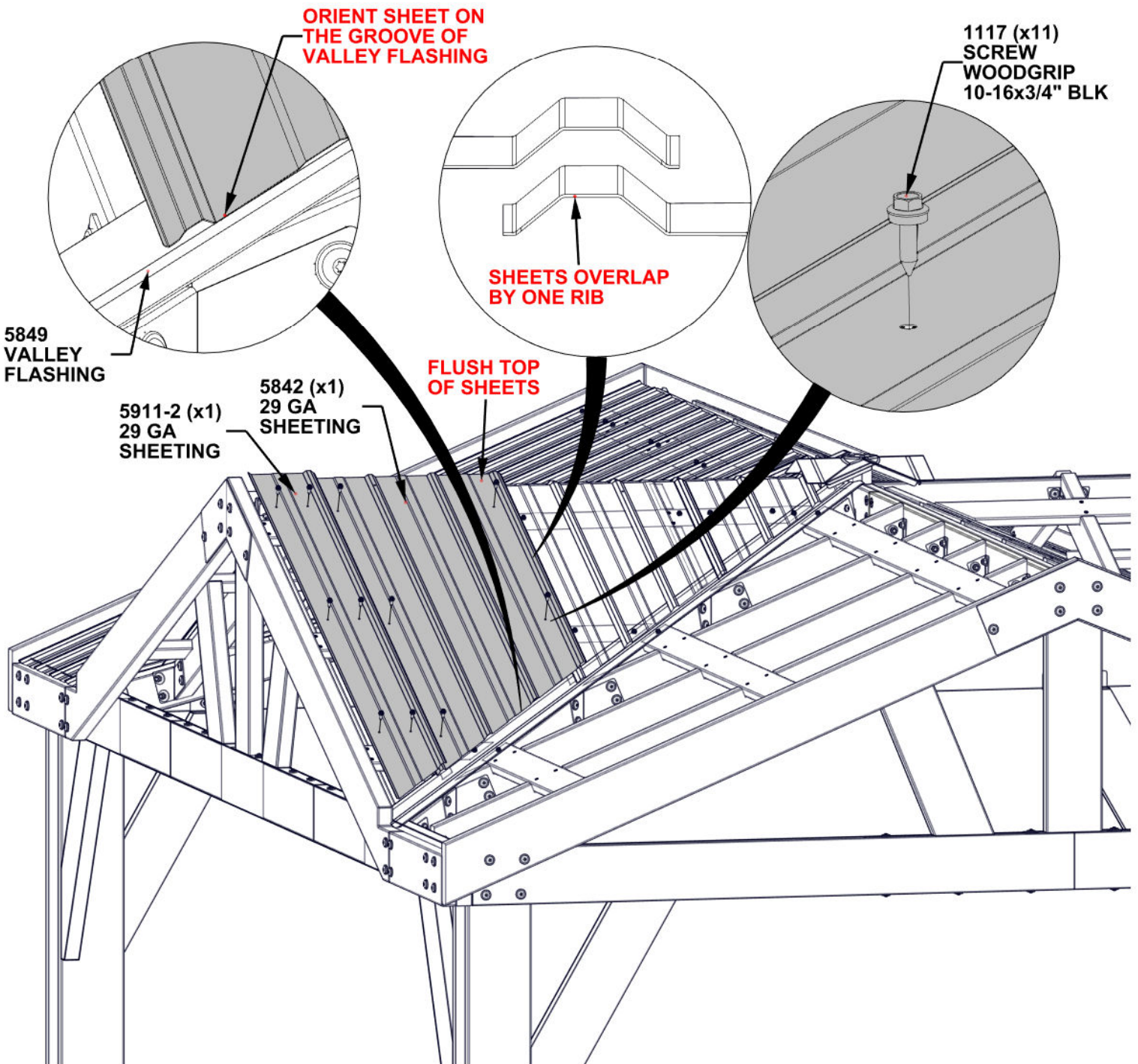

STEP 52A - ROOF ASSEMBLY

Qty	PartNo	Description
2	H101117	SCREW WOODGRIP 10-16x3/4" BLK

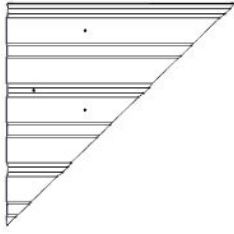

A4M05908-2 29 GA STEEL SHEETING
(x1)

- REMOVE PROTECTIVE FILM.
- SLIDE SHEET UNDER THE RIDGE CAP SPLICE, MAKING SURE THE LOWER END IS ON THE GROOVE OF VALLEY FLASHING.
- ATTACH SCREWS AND TIGHTEN ALL HARDWARE.
- **WARNING: GLOVES ARE RECOMMENDED WHEN HANDLING STEEL ROOF PIECES.**

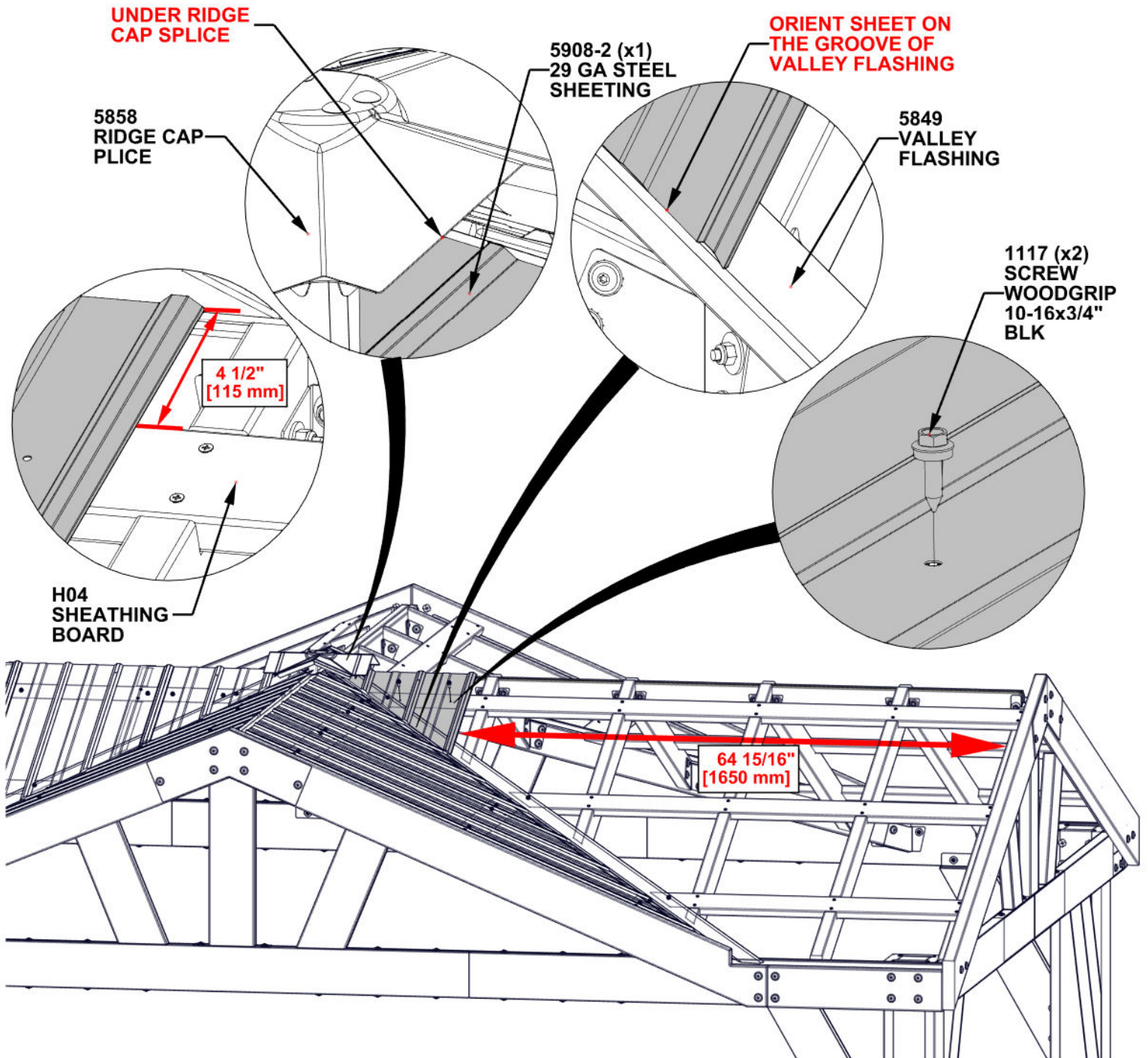

STEP 52B - ROOF ASSEMBLY

Qty	PartNo	Description
3	H101117	SCREW WOODGRIP 10-16x3/4" BLK

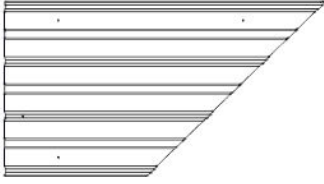

A4M05908-1 29 GA STEEL SHEETING
(x1)

- REMOVE PROTECTIVE FILM.
- SLIDE SHEET FROM OUTSIDE TO CENTER, MAKING SURE THE LOWER END IS ON THE GROOVE OF VALLEY FLASHING AND TOP OF SHEETS ARE FLUSH.
- ATTACH SCREWS AND TIGHTEN ALL HARDWARE.
- **WARNING: GLOVES ARE RECOMMENDED WHEN HANDLING STEEL ROOF PIECES.**

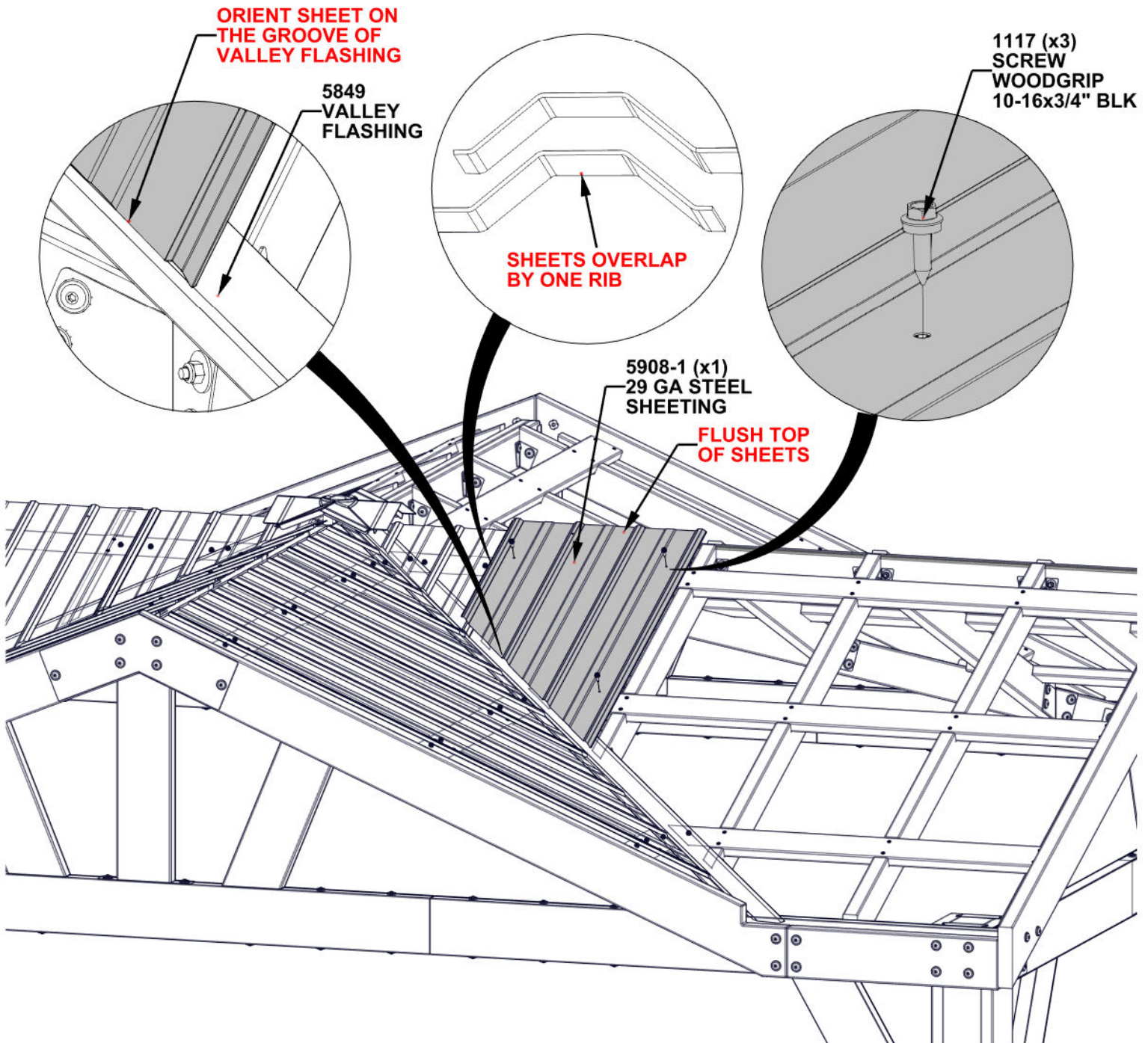

STEP 52C - ROOF ASSEMBLY

Qty	PartNo	Description
17	H101117	SCREW WOODGRIP 10-16x3/4" BLK

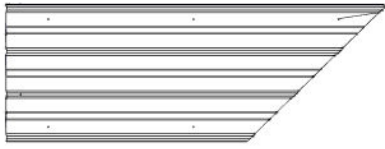

A4M05786 29 GA SHEETING
(x1)

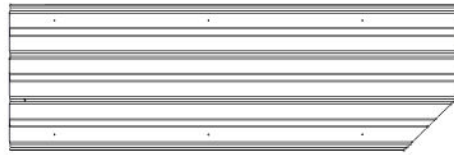

A4M05256 29 GA SHEETING
(x1)

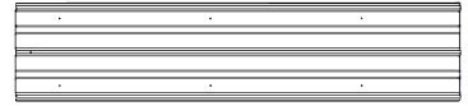

A4M05257 29 GA SHEETING
(x1)

- REMOVE PROTECTIVE FILM.
- INSTALL THREE SHEETS IN THE SAME WAY AS THE PREVIOUS STEP.
- ATTACH AND FULLY TIGHTEN ALL SCREWS ON EACH ROOF SHEET BEFORE ATTACHING THE NEXT ONE. THIS MAKES IT POSSIBLE TO REACH ALL THE SCREWS WITHOUT GETTING ON THE ROOF.
- **WARNING: GLOVES ARE RECOMMENDED WHEN HANDLING STEEL ROOF PIECES.**

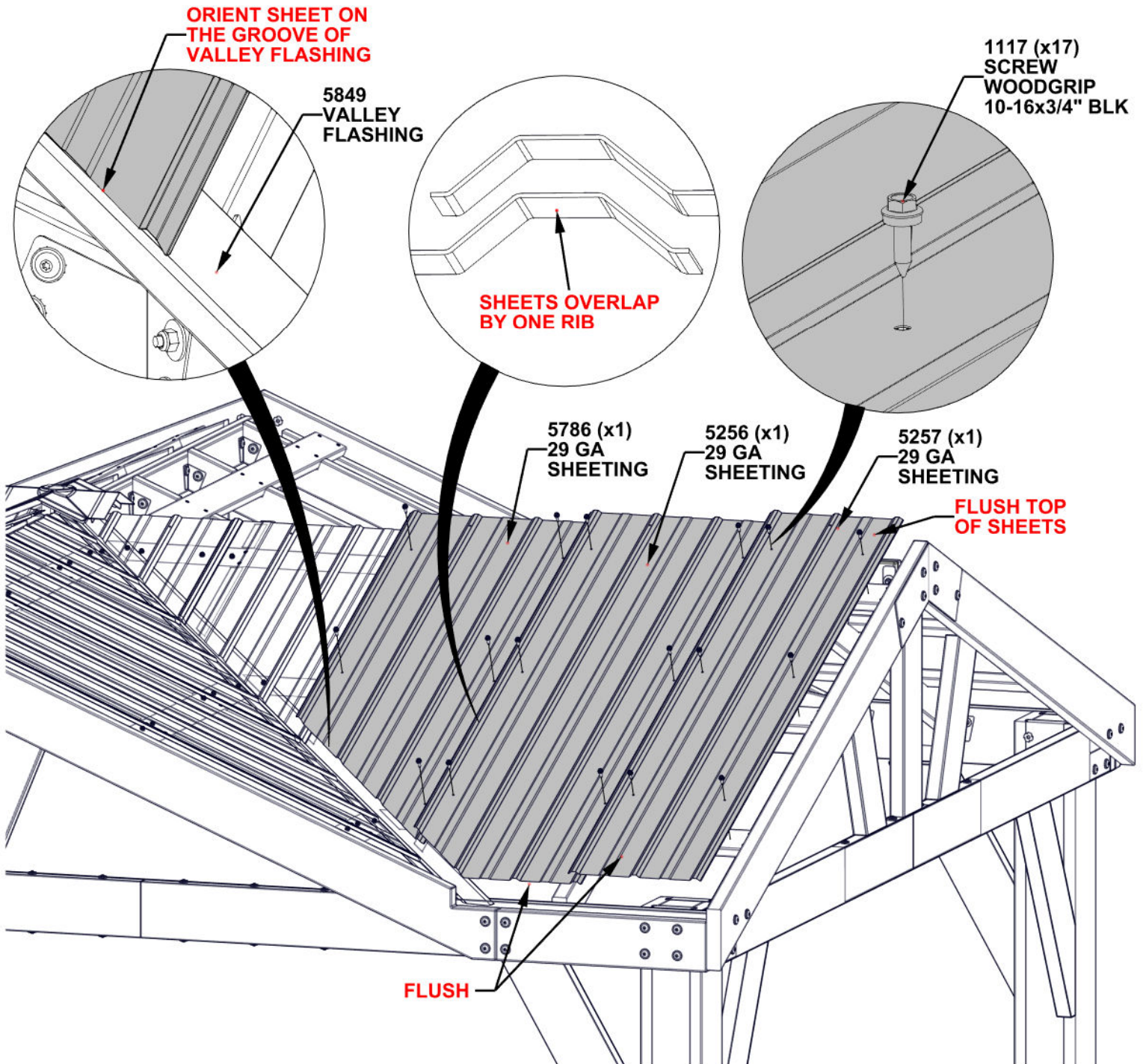

**REPEAT ROOF ASSEMBLY STEPS 47 - 52C
TO INSTALL VALLEY SPLICE COVERL AND SHEETMETAL
ON OPPOSITE SIDE OF ROOF**

STEP 53 - ROOF ASSEMBLY

Qty	PartNo	Description
8	H101116	SCREW SELF TAPPING 1/4x1 BLK

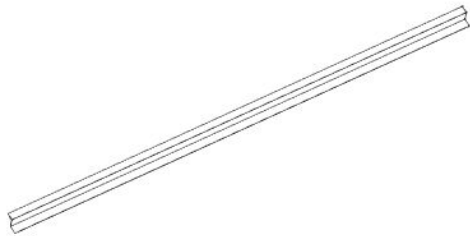

A4M05852 Z-TRIM
(x1)

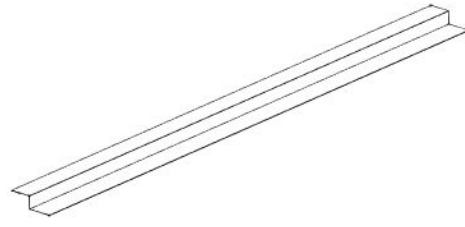

A4M05853 Z-TRIM
(x1)

- DUE TO MULTIPLE LAYERS OF METAL ON THE DRIP EDGE, IT IS RECOMMENDED THAT A 1/8" (3mm) DRILL BIT BE USED TO CREATE STARTER HOLES.
- WARNING: GLOVES ARE RECOMMENDED WHEN HANDLING STEEL ROOF PIECES.
- REMOVE PROTECTIVE FILM.
- WITH ONE EXTRA PERSON, ORIENT 5852, 5853 AS BELOW SHOWN.

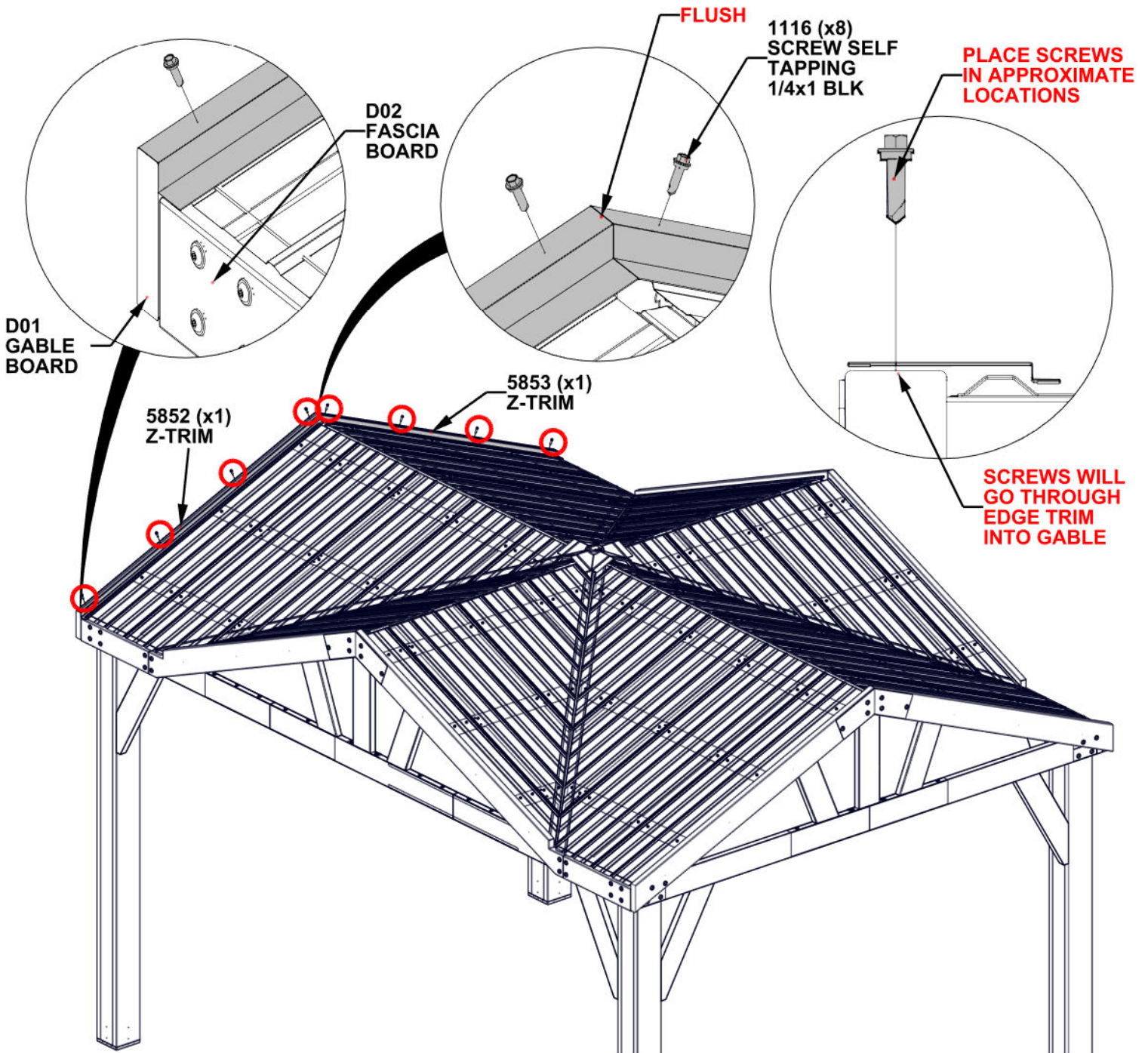

STEP 54 - ROOF ASSEMBLY

Qty	PartNo	Description
8	H101116	SCREW SELF TAPPING 1/4x1 BLK

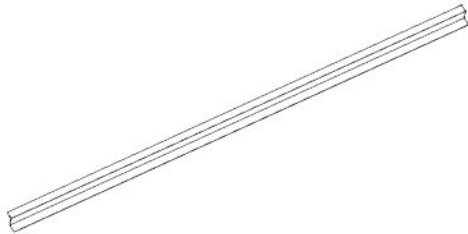

A4M05852 Z-TRIM
(x1)

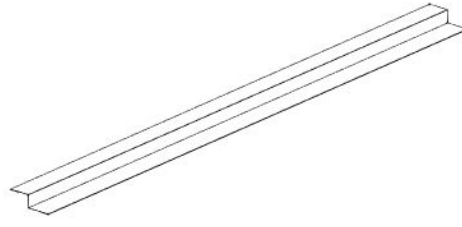

A4M05853 Z-TRIM
(x1)

- DUE TO MULTIPLE LAYERS OF METAL ON THE DRIP EDGE, IT IS RECOMMENDED THAT A 1/8" (3mm) DRILL BIT BE USED TO CREATE STARTER HOLES.
- WARNING: GLOVES ARE RECOMMENDED WHEN HANDLING STEEL ROOF PIECES.
- REMOVE PROTECTIVE FILM.
- WITH ONE EXTRA PERSON, ORIENT 5852, 5853 AS BELOW SHOWN.

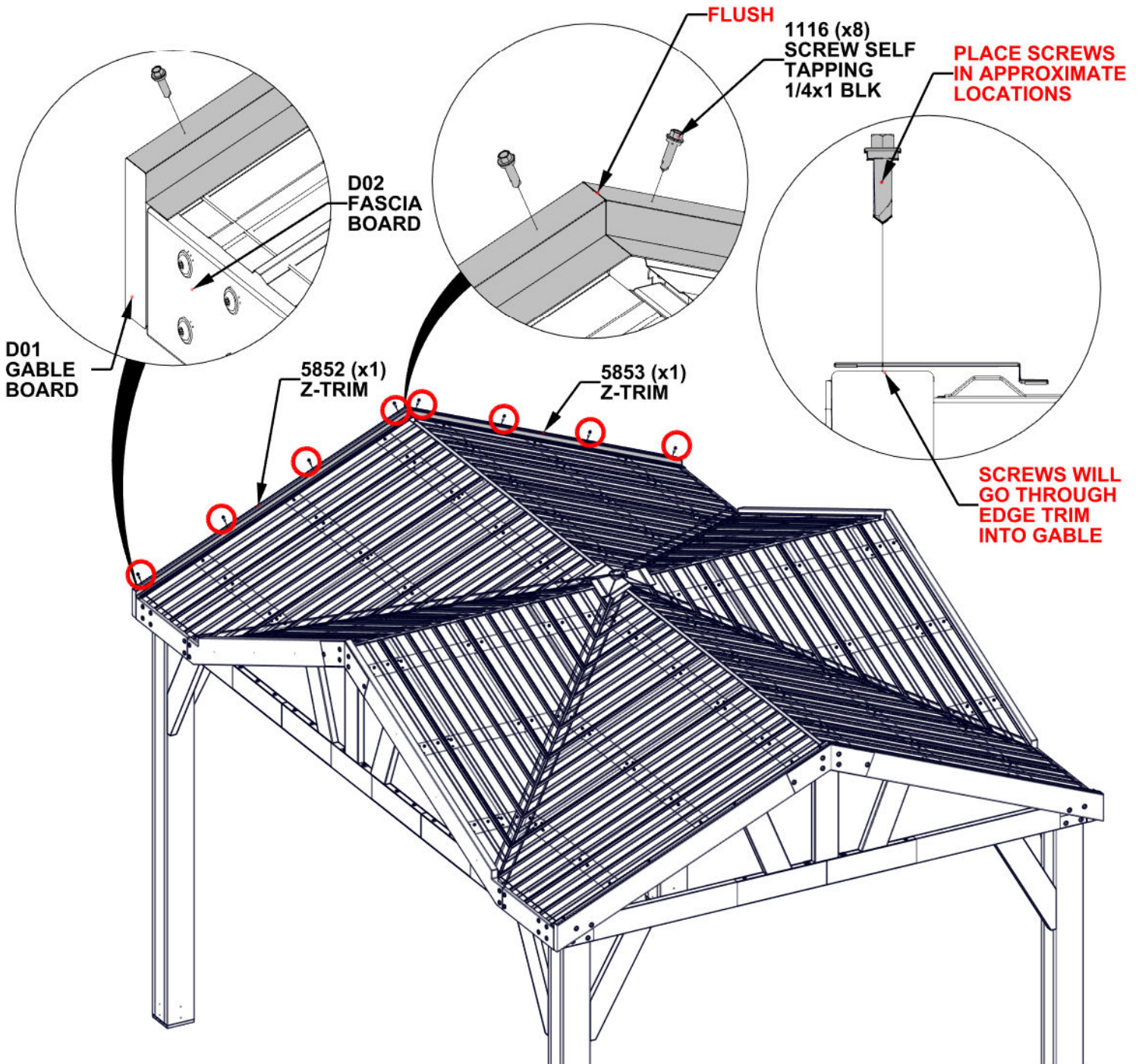

STEP 55 - ROOF ASSEMBLY

Qty	PartNo	Description
16	H101116	SCREW SELF TAPPING 1/4x1 BLK

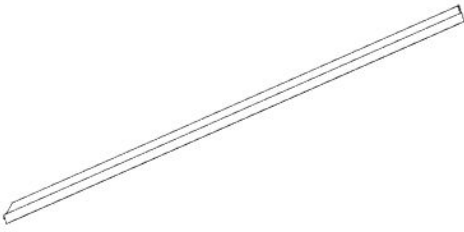

A4M05854 Z-TRIM
(x1)

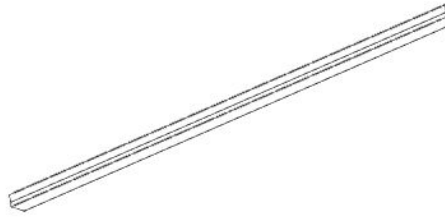

A4M05855 Z-TRIM
(x1)

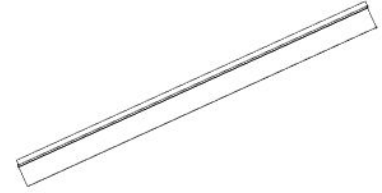

A4M05856 DRIP TRIM
(x2)

- DUE TO MULTIPLE LAYERS OF METAL ON THE DRIP EDGE, IT IS RECOMMENDED THAT A 1/8" (3mm) DRILL BIT BE USED TO CREATE STARTER HOLES.
- WARNING: GLOVES ARE RECOMMENDED WHEN HANDLING STEEL ROOF PIECES.
- REMOVE PROTECTIVE FILM.
- WITH ONE EXTRA PERSON, ORIENT 5856, 5854, 5855 AS BELOW SHOWN.

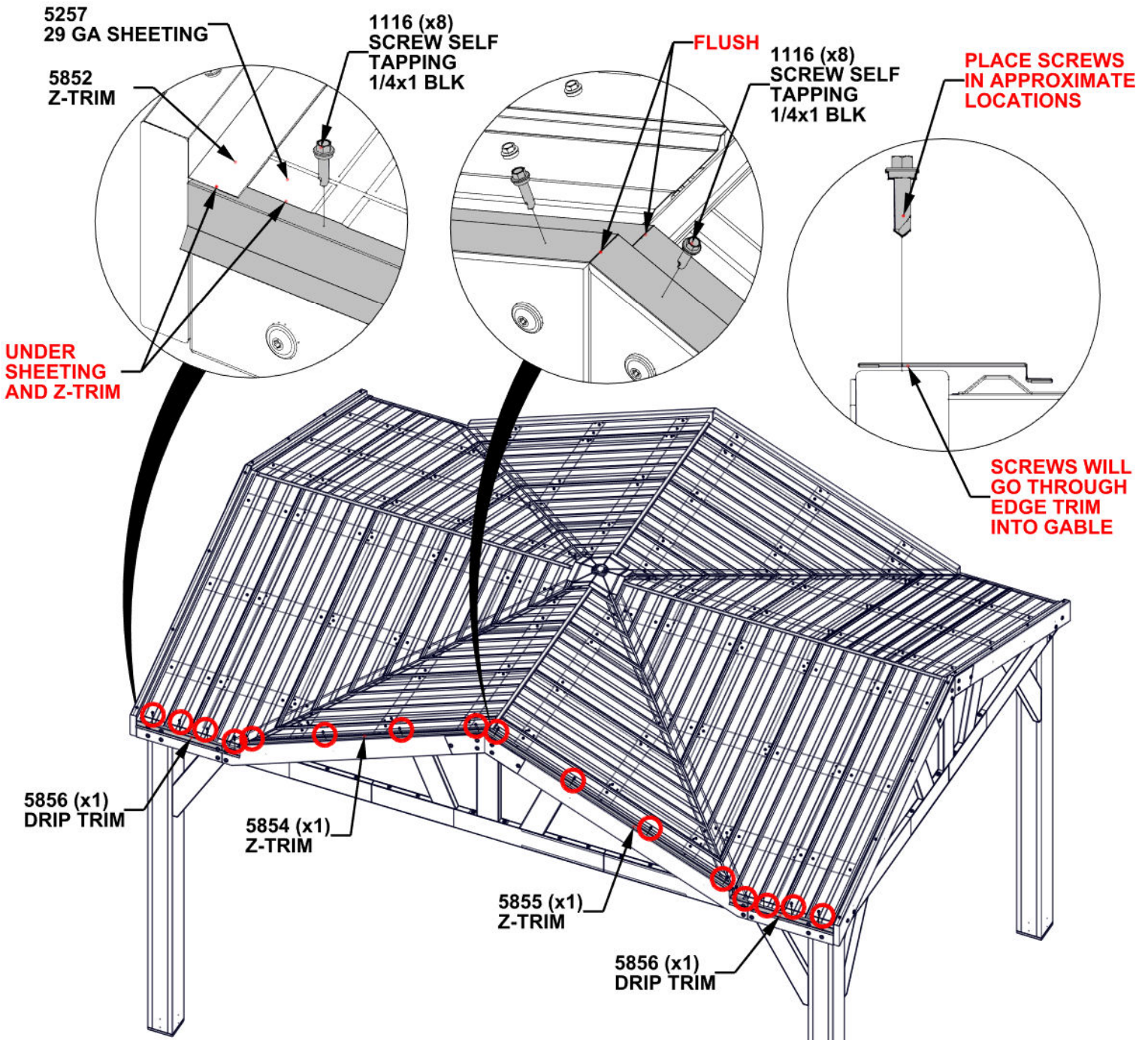

STEP 56 - ROOF ASSEMBLY

Qty	PartNo	Description
16	H101116	SCREW SELF TAPPING 1/4x1 BLK

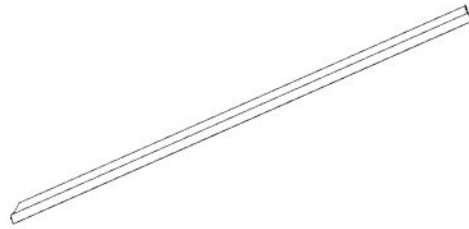

A4M05854 Z-TRIM
(x1)

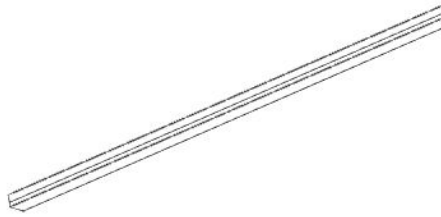

A4M05855 Z-TRIM
(x1)

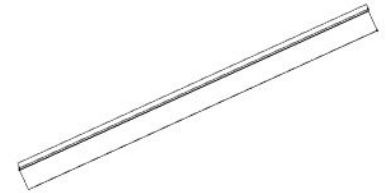

A4M05856 DRIP TRIM
(x2)

- DUE TO MULTIPLE LAYERS OF METAL ON THE DRIP EDGE, IT IS RECOMMENDED THAT A 1/8" (3mm) DRILL BIT BE USED TO CREATE STARTER HOLES.
- WARNING: GLOVES ARE RECOMMENDED WHEN HANDLING STEEL ROOF PIECES.
- REMOVE PROTECTIVE FILM.
- WITH ONE EXTRA PERSON, ORIENT 5856, 5854, 5855 AS BELOW SHOWN.

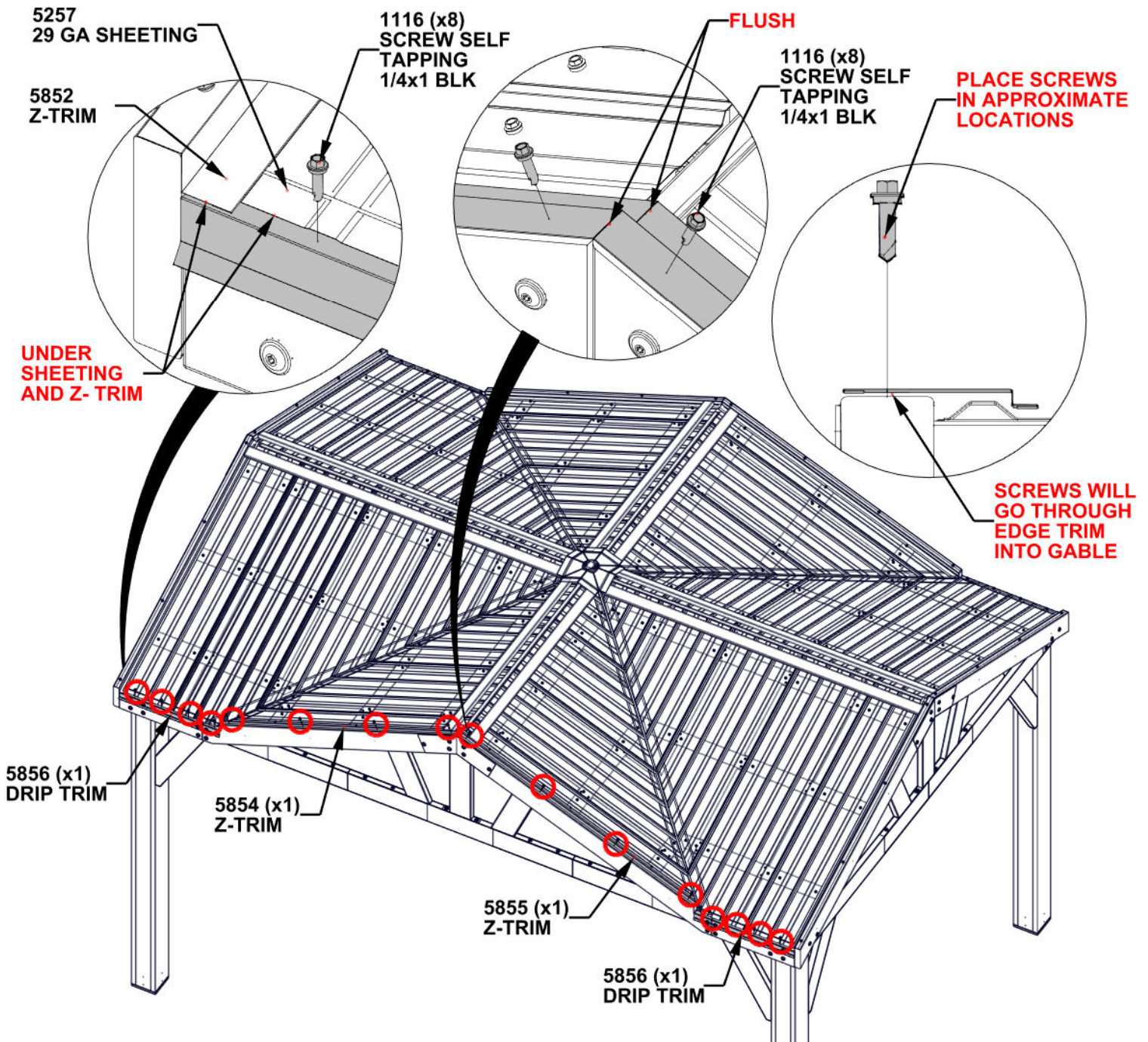

STEP 57A - RIDGE CAP ASSEMBLY

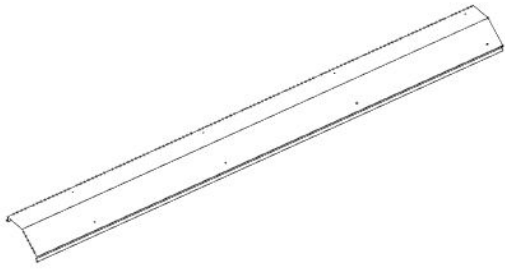

A4M05850 RIDGE CAP
(x2)

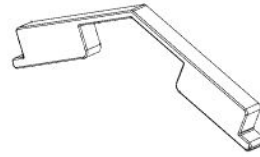

A6P00398 RIDGE CAP PROTECTOR
(x4)



J01 RIDGE CAP STIFFENER - W4L22270
(x4) 1"X2 3/8"X78 1/2" (24x60x1993)

- POSITION RIDGE CAP STIFFENERS AS SHOWN BELOW.
 - REMOVE SPACERS FROM RIDGE CAP PROTECTORS BEFORE INSTALLING.
 - SLIDE RIDGE CAP PROTECTOR ONTO RIDGE CAP AND RIDGE CAP STIFFENER.
 - GENTLY TAP ENDS OF ASSEMBLY WITH RUBBER Mallet UNTIL GAP CLOSES.
- REPEAT THIS STEP 2 TIMES.**

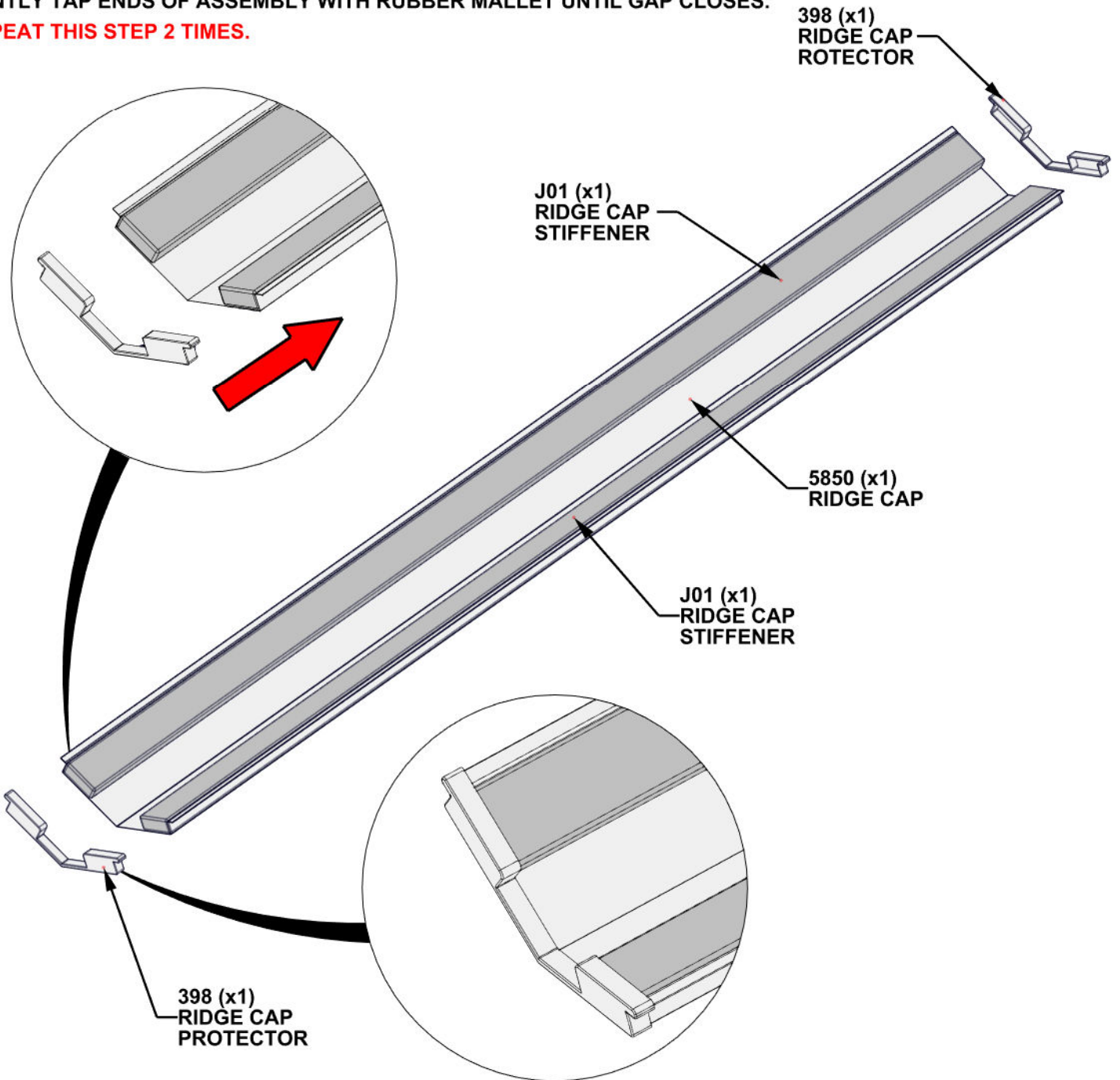

STEP 57B - RIDGE CAP ASSEMBLY

Qty	PartNo	Description
16	H101117	SCREW WOODGRIP 10-16x3/4" BLK

- ALIGN PILOT HOLES AND TIGHTEN ALL SCREWS.
- REPEAT THIS STEP 2 TIMES.

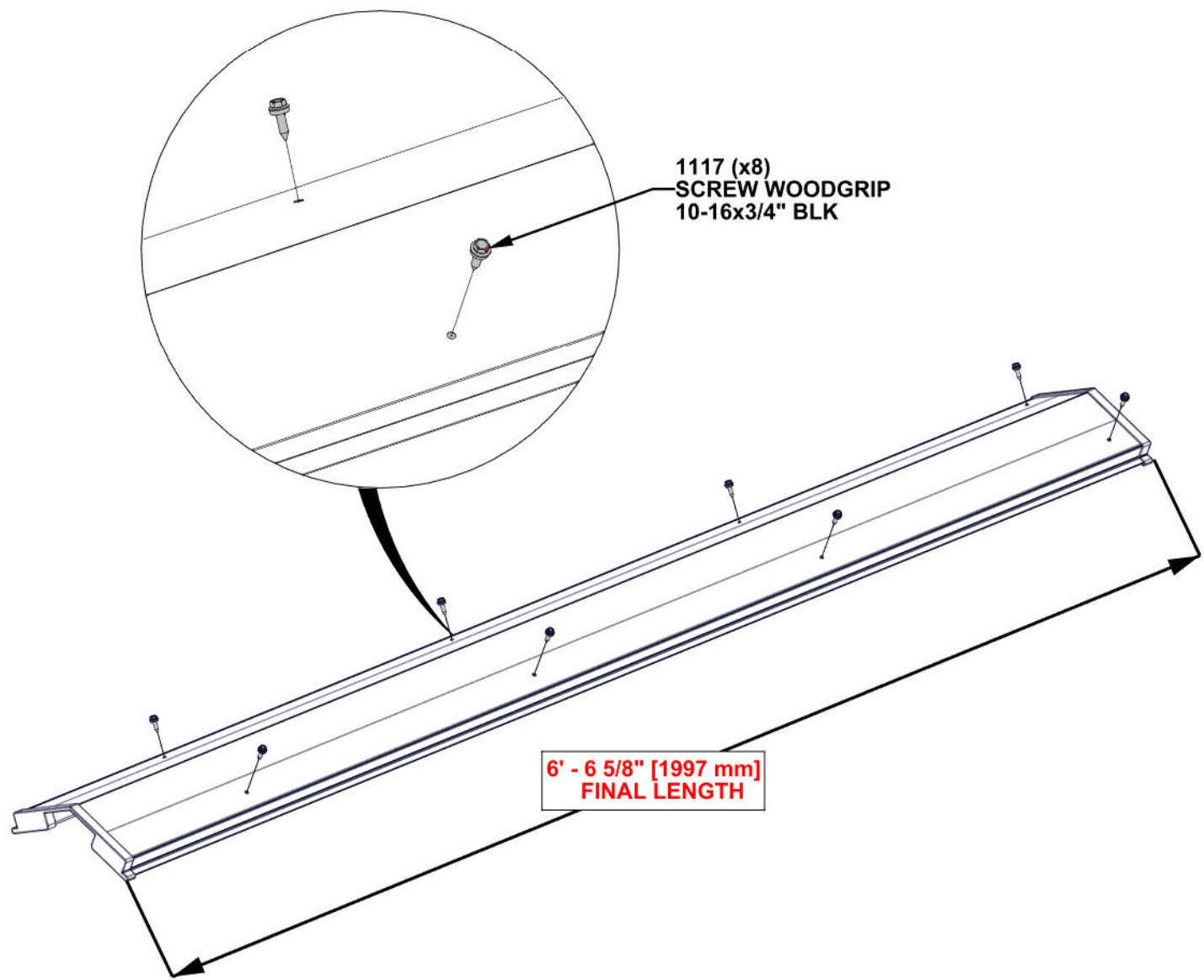

STEP 58A - RIDGE CAP ASSEMBLY

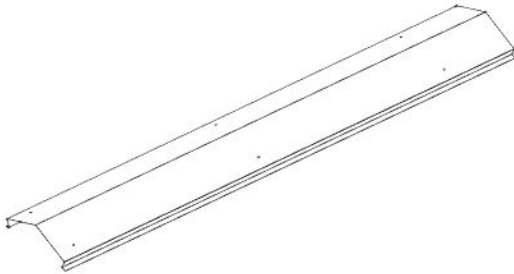

A4M05851 RIDGE CAP
(x2)

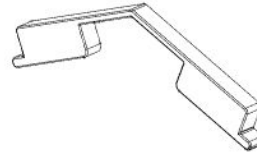

A6P00398 RIDGE CAP PROTECTOR
(x4)



J02 RIDGE CAP STIFFENER - W4L22271
(x4) 1"X2 3/8"X53 1/2" (24x60x1360)

- POSITION RIDGE CAP STIFFENERS AS SHOWN BELOW.
- REMOVE SPACERS FROM RIDGE CAP PROTECTORS BEFORE INSTALLING.
- SLIDE RIDGE CAP PROTECTOR ONTO RIDGE CAP AND RIDGE CAP STIFFENER.
- GENTLY TAP ENDS OF ASSEMBLY WITH RUBBER Mallet UNTIL GAP CLOSES.

- REPEAT THIS STEP 2 TIMES.

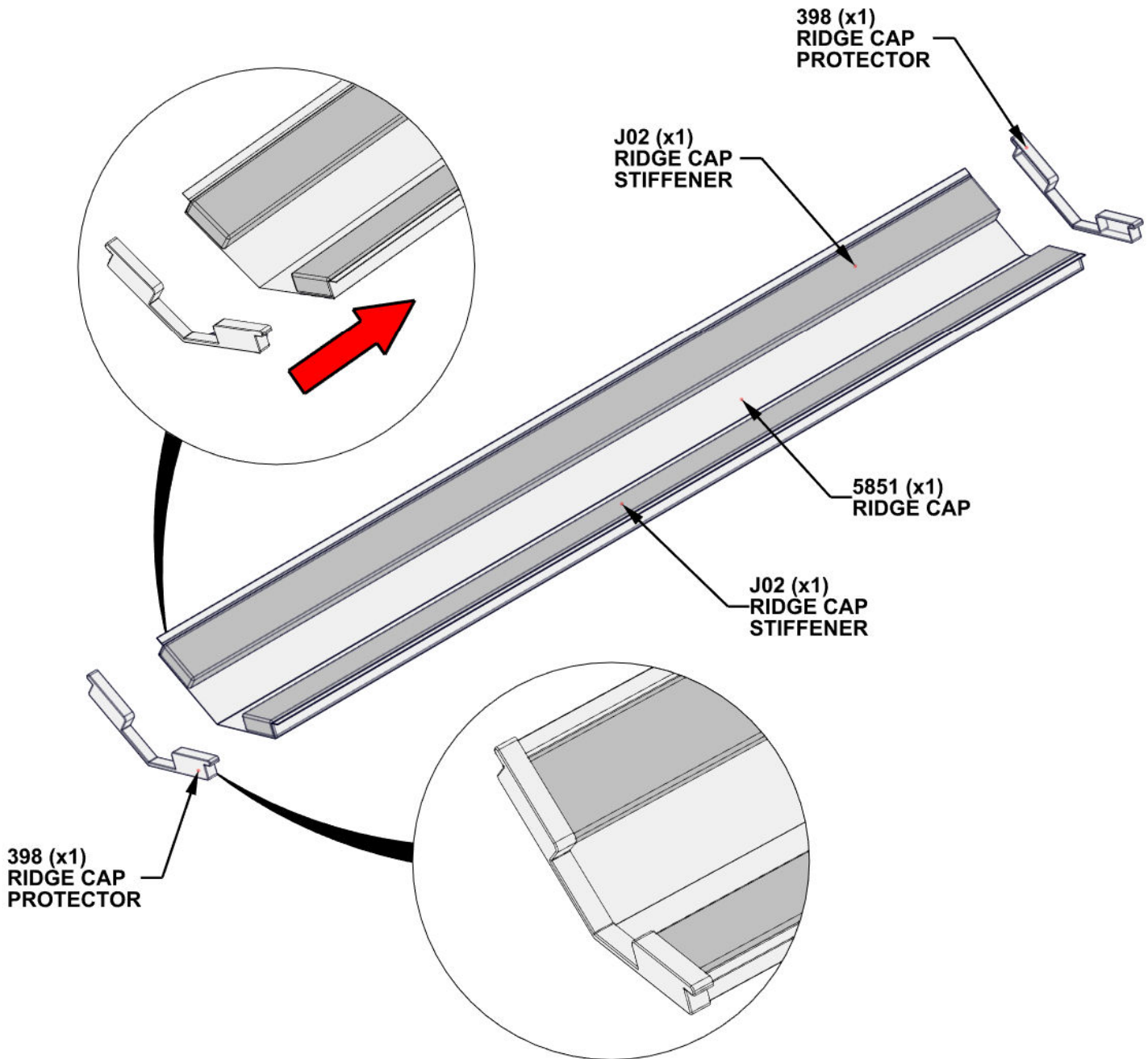

STEP 58B - RIDGE CAP ASSEMBLY

Qty	PartNo	Description
12	H101117	SCREW WOODGRIP 10-16x3/4" BLK

- ALIGN PILOT HOLES AND TIGHTEN ALL SCREWS.
- REPEAT THIS STEP 2 TIMES.

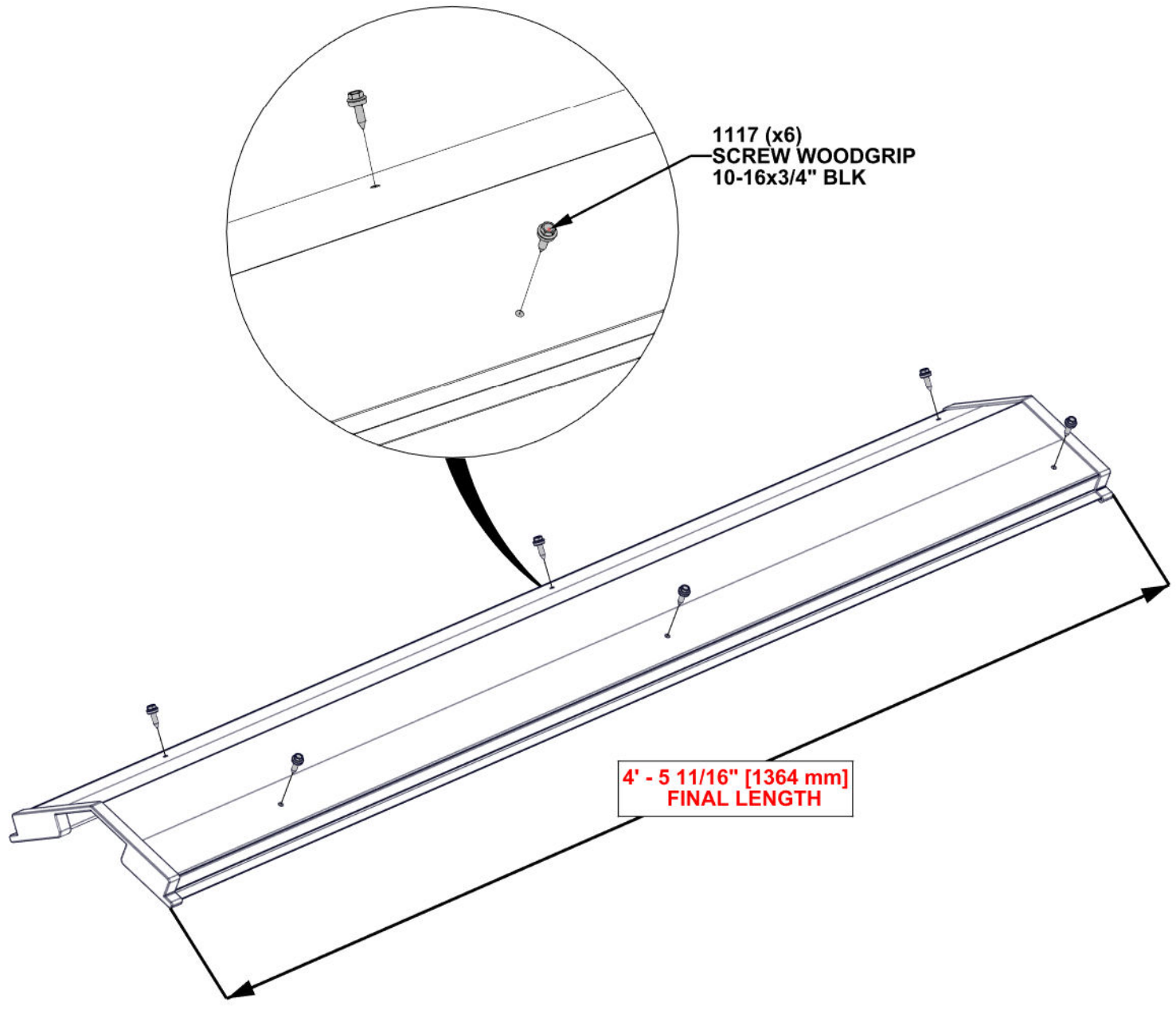

STEP 59 - ROOF ASSEMBLY

Qty	PartNo	Description
12	H100392	SCREW PWH 8x3/4 BLK

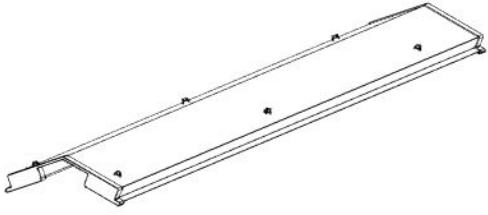

RIDGE CAP ASSEMBLY FROM STEP 58A-58B

- SLIDE RIDGE CAP UNDER RIDGE CAP SPLICE.
- ADD SCREWS UNDER GAZEBO AND TIGHTEN ALL HARDWARE.

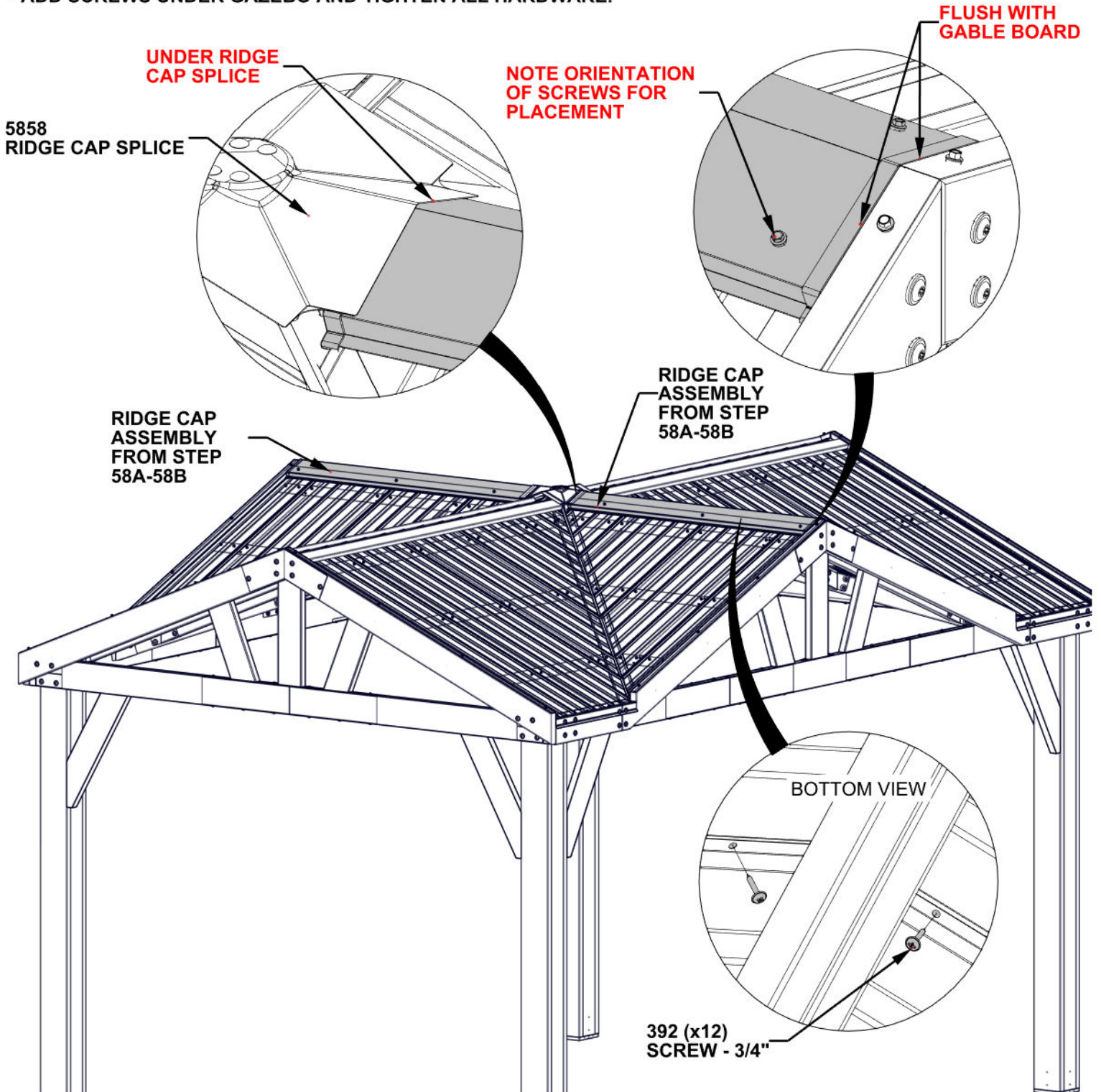

STEP 60 - ROOF ASSEMBLY

Qty	PartNo	Description
20	H100392	SCREW PWH 8x3/4 BLK

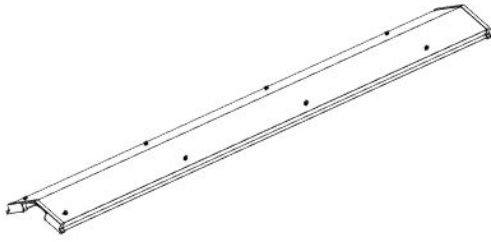

RIDGE CAP ASSEMBLY FROM STEP 57A-57B

- SLIDE RIDGE CAP UNDER RIDGE CAP SPLICE.
- ADD SCREWS UNDER GAZEBO AND TIGHTEN ALL HARDWARE.

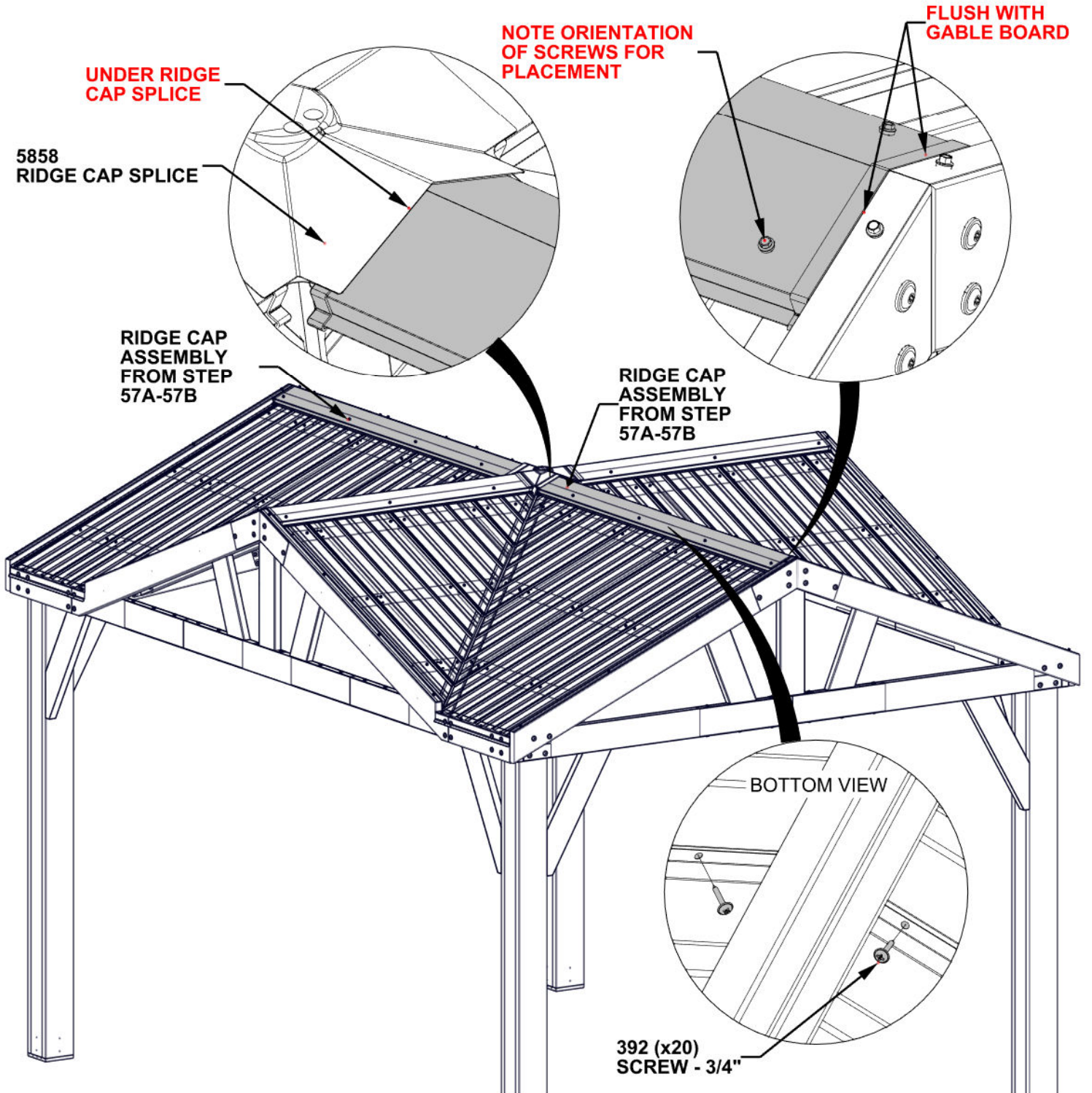

STEP 61 - ANCHORING

Qty	PartNo	Description
32	H100854	LAG SCREW WH 5/16x1 BLK

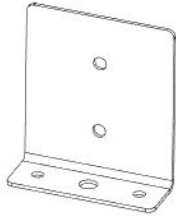

A4M00977 POST ANCHORING PLATE WITH FLANGE
(x8)

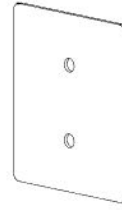

A4M00978 POST PLATE
(x8)

- ALIGN ANCHOR PLATES WITH PILOT HOLES IN EACH POST.

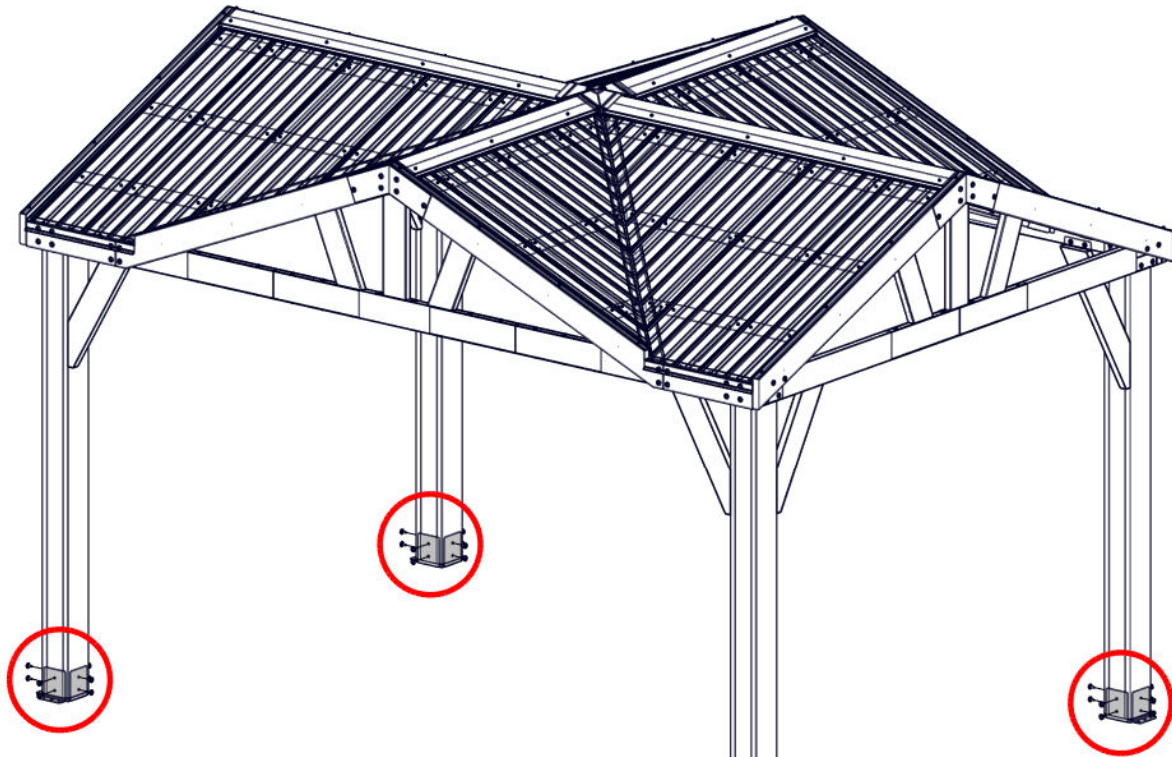

977 (x8)
POST
ANCHORING
PLATE WITH
FLANGE

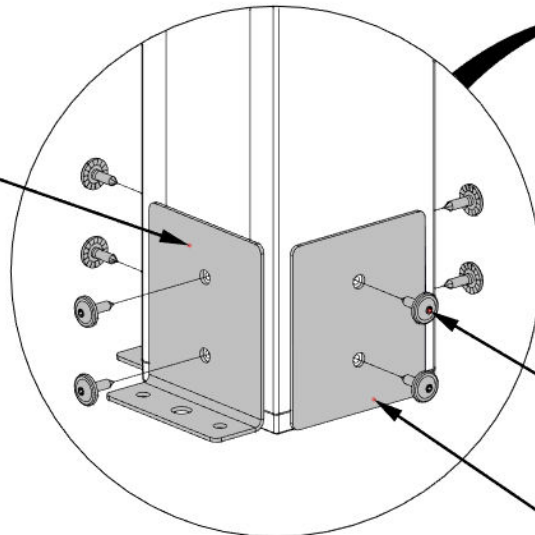

854 (x32)
LAG SCREW - 1"

978 (x8)
POST PLATE

STEP 62 - ANCHORING

Qty	PartNo	Description
16	H100120	CONCRETE ANCHOR
16	H100630	WASHER FLAT 8x19 BLK

- MANUFACTURER RECOMMENDS INSTALLATION ON CONCRETE SURFACE OR CONCRETE POST PADS. SEE BELOW.
- FOR INSTALLATION ON WOOD DECKS, YOU MUST ENSURE THERE IS AMPLE STRUCTURAL SUPPORT UNDER DECK.
- REPEAT THIS STEP FOR ALL FOUR POST.

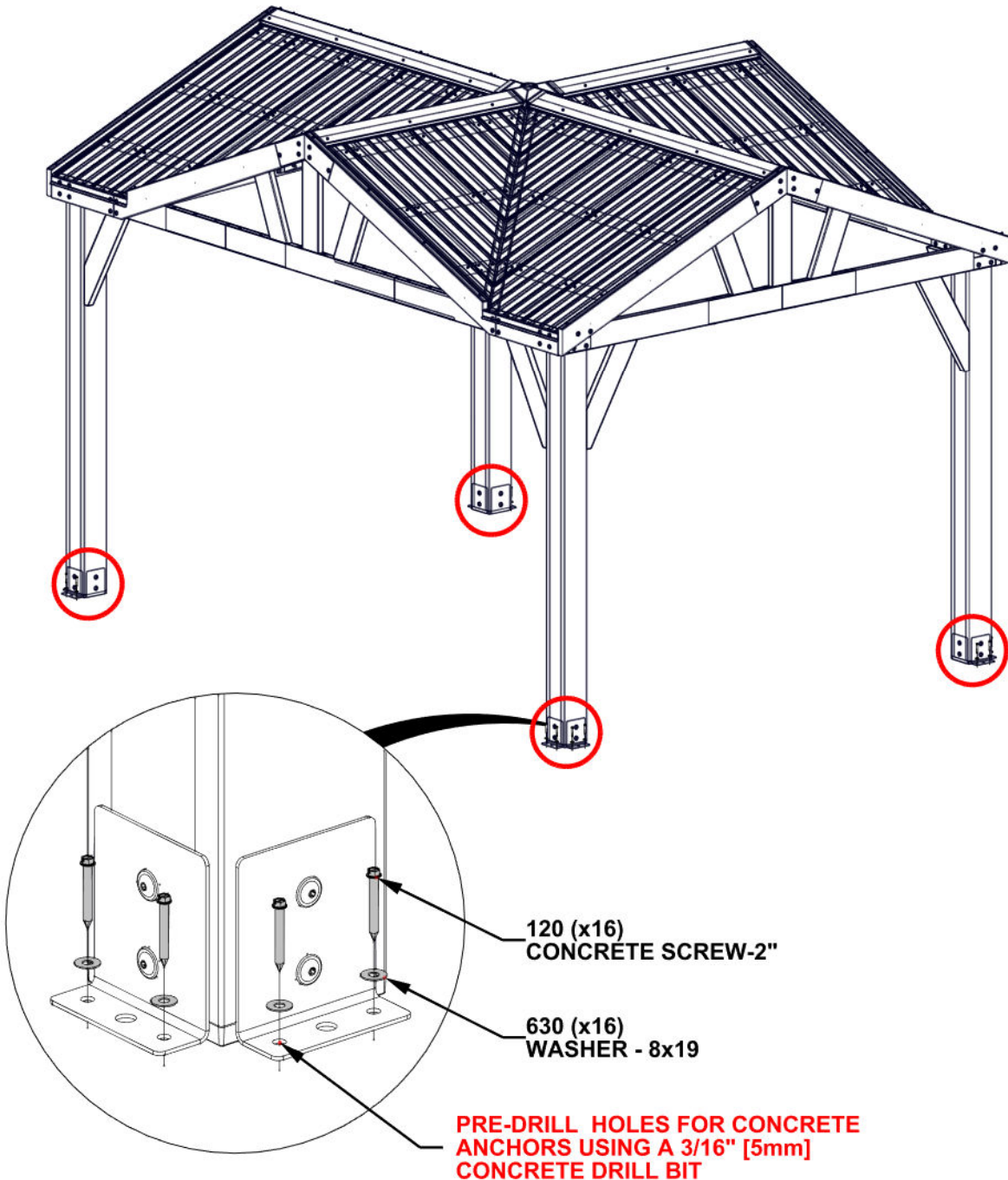

STEP 63 - ID TAG INSTALLATION

Qty	PartNo	Description
4	H100392	SCREW PWH 8x3/4 BLK



A4M02158 BYD ID TAG PATIO
(x1)

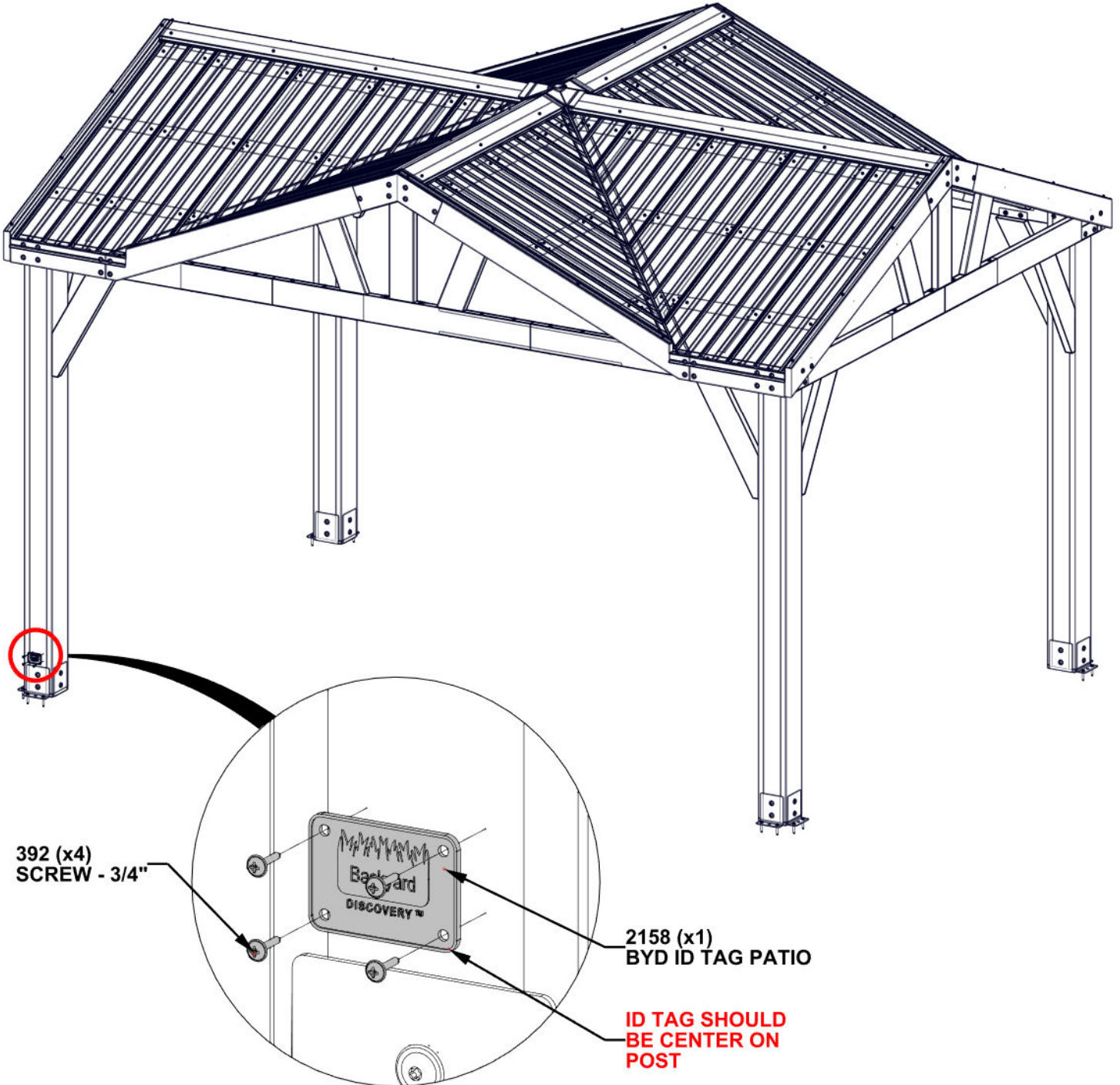

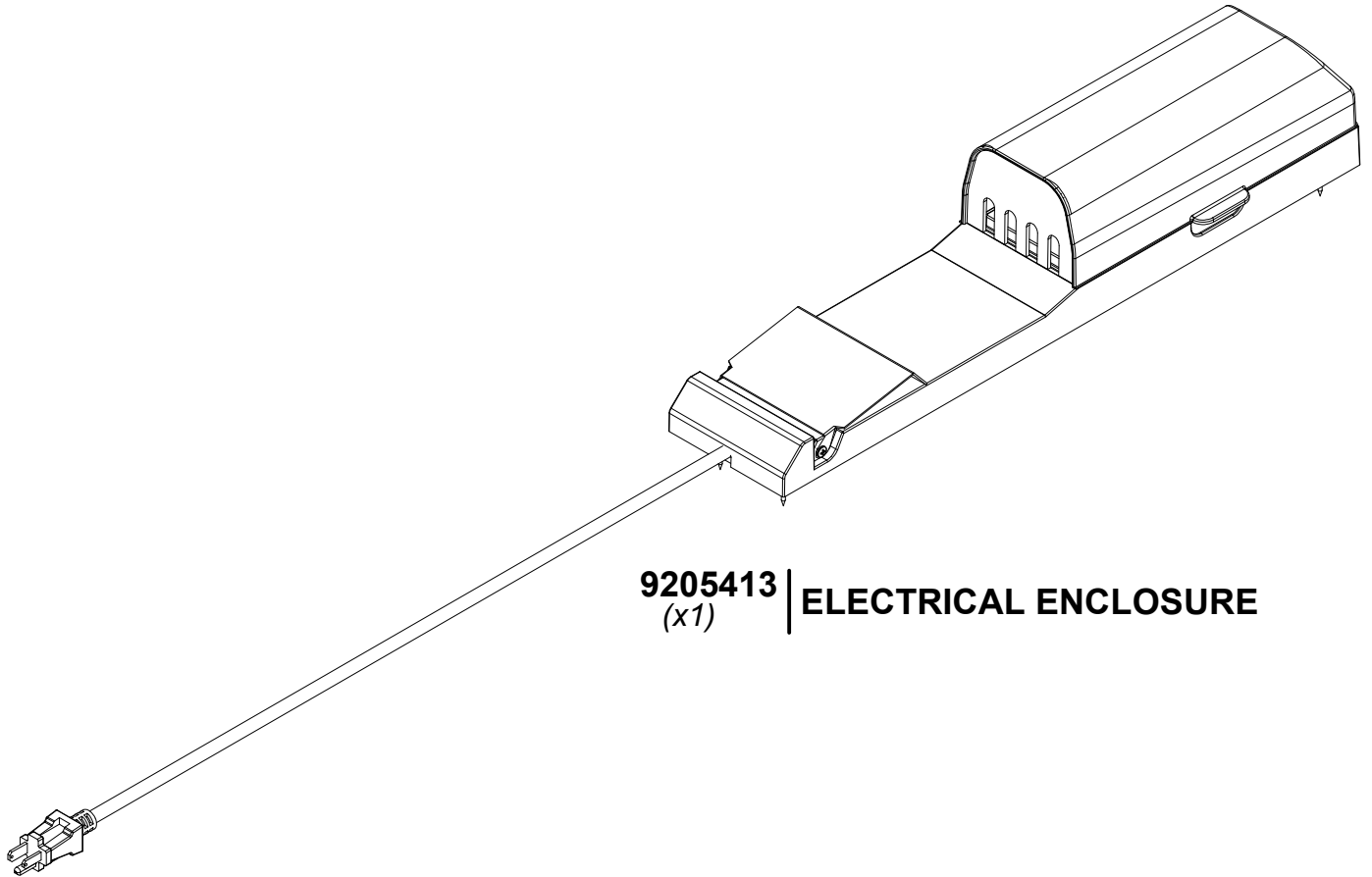

9205413 | **ELECTRICAL ENCLOSURE**
(x1)

FOR POWERPORT INSTALLATION REFER TO ASSEMBLY INSTRUCTIONS THAT COME PACKAGED WITH THE POWERPORT KIT. INSTALL ON ANY EXTERIOR POST THAT IS DESIRED. FOLLOW DIRECTIONS FOR PROPER INSTALLATION.