



Manufactured by:
Backyard Discovery
3305 Airport Drive, Pittsburg, KS 66762
800-856-4445

Basepoint Business Centre: Rivermead Drive, Westlea, Swindon SN5 7EX Phone: 0800-118-2476
J.P. Coenstraat 7, The Bridge, The Hague, 2595 WP, Netherlands Phone: 08005678990

TIMBERLAKE

PLAYHOUSE

MODEL: # 65314



WARNING

Adult Assembly Required.

The assembly manual must be retained since it contains important information
Not suitable for children under two years due to sharp points and small parts.
FOR DOMESTIC USE ONLY. INTENDED FOR OUTDOOR USE.



Please visit www.backyarddiscovery.com

For the most up to date assembly manual, to register your product, or to order replacement parts

Para obtener instrucciones en español, visite www.backyarddiscovery.com



EASY STEP-BY-STEP
3D INTERACTIVE INSTRUCTIONS
DOWNLOAD THE FREE APP



SAFETY AND ASSEMBLY INFORMATION

SELECTING THE CORRECT LOCATION FOR YOUR PLAY PRODUCT IS IMPORTANT FOR YOUR CHILDREN'S SAFETY AND THE PRODUCT'S LONGEVITY

Dimensions:

- The Timberlake has one layout option.

Layout Ground Dimension
3'-6" x 3'-10 11/16" x 56" Tall

Safe Play Area*
15'-6" x 15'-10 3/4"

*Level Ground Surface - See below

General Information:

Your set has been designed and engineered for children only and for residential use only. A maximum of 150 lbs. per child is recommended for play activities designed for individual use. A maximum of 120 lbs. per child is recommended for play activities designed for multiple child use. A maximum of 6 children is recommended for this unit.

Safe Play Area:

- The safe play area refers to a zone extending 6' beyond the play product on all sides, including the space above the play product.
- The ground surface **must be level**. Installing your play product on sloping ground can cause it to lean or "rack". This leaning puts additional stress on all connections and joints and in time will cause those connections to loosen and fail.
- The safe play area must be free of all structures, landscaping, trees and branches, rocks, wires, and other obstacles to safe play. Children can be seriously injured running or swinging into these obstacles.
- Remove all tripping hazards from the safe play area. Tripping hazards include: roots, stumps, rocks, landscaping, sprinkler heads, railroad ties, plumbing and electrical connections.
- Play product needs to be installed on solid ground.

SAFE PLAY AREA DIAGRAM

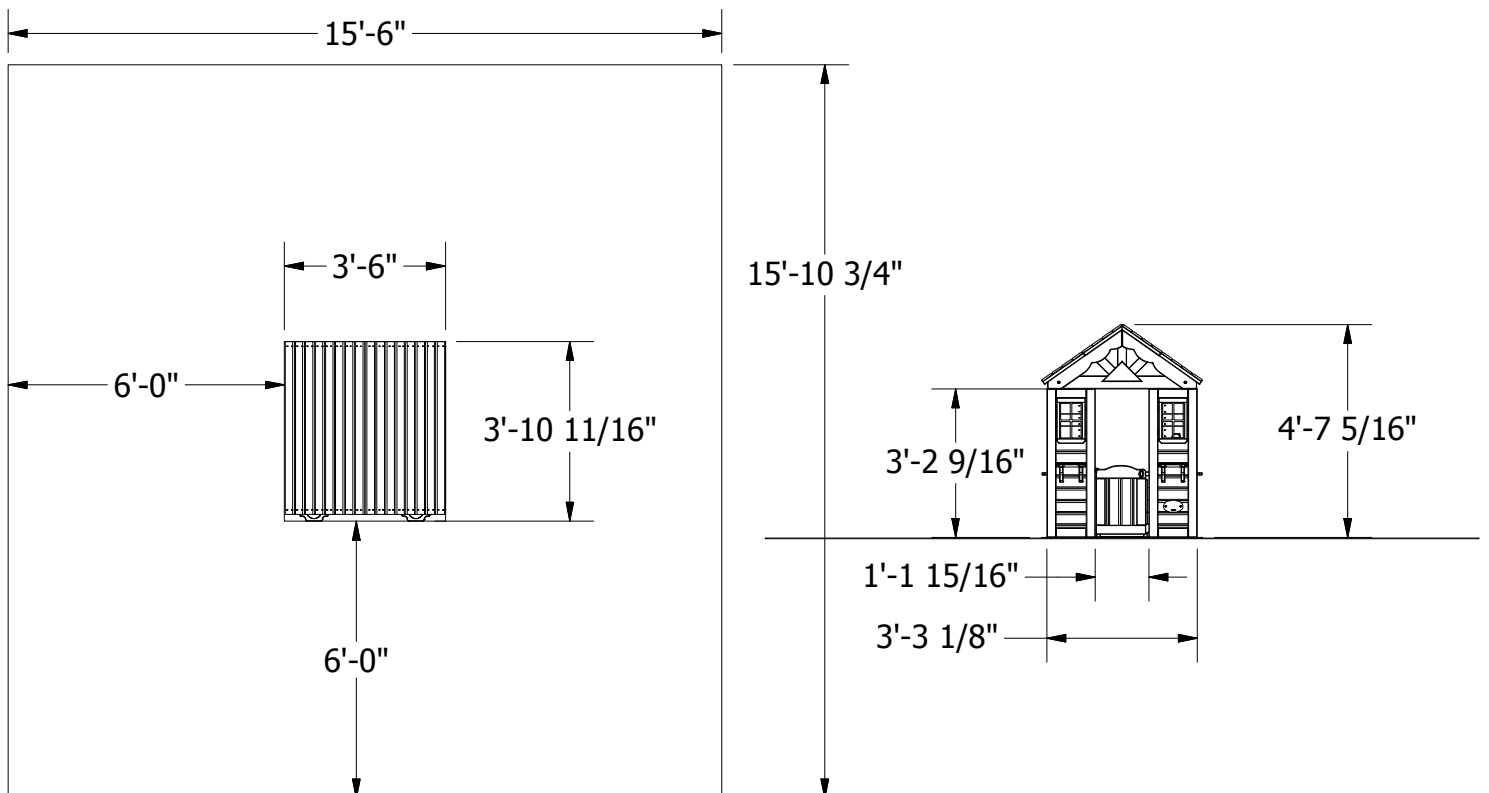

Parts Identification

Wood Components

(NOT TO SCALE)

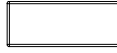

- (1) **J1 - COUNTER TOP SUPPORT - W4L04753**
1"x2 3/8"x5 7/8" (24x60x150)

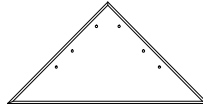

- (2) **K1 - TRIANGLE SUNBURST - W4L04871**
5/8"x5 1/4"x10 3/8" (16x134x265)

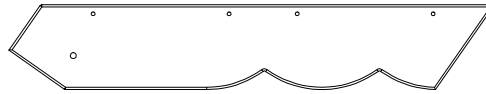

- (4) **L1 - GABLE BOARD - W4L04755**
5/8"x4 3/8"x25 3/8" (16x112x643)



- (2) **M1 - COUNTER TOP - W4L04754**
5/8"x3 3/8"x23 5/8" (16x86x600)

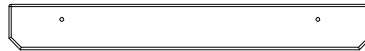

- (2) **N1 - SIDE WINDOW SHELF - W4L04751**
5/8"x2 3/8"x18 7/8" (16x60x479)



- (1) **N2 - REAR WINDOW SHELF - W4L04760**
5/8"x2 3/8"x19 1/8" (16x60x485)



- (1) **N3 - DOOR STOP - W4L04761**
5/8"x2 3/8"x3 7/8" (16x60x100)



- (8) **N4 - TIE STRAP - W102424**
5/8"x2"x3 1/8" (16x50x80)



- (2) **N5 - SUNBURST LEG - W4L04872**
5/8"x2 3/8"x10 1/4" (16x60x260)

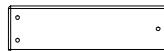

- (4) **N6 - SUNBURST LEG - W4L04873**
5/8"x2 3/8"x8 1/4" (16x60x210)



- (1) **Q1 - COUNTER TOP SUPPORT - W4L04752**
1"x4 3/8"x5 7/8" (24x112x150)

Parts Identification

Wood Components

(NOT TO SCALE)

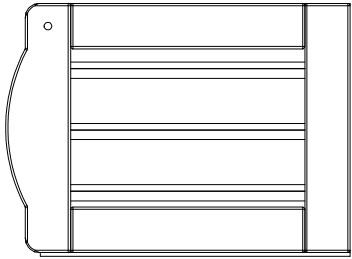

(1) DP1 - DOOR ASSEMBLY - W2A01511

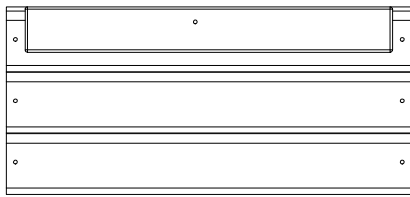

(1) WP7 - UPPER REAR CENTER WALL
- W2A01522

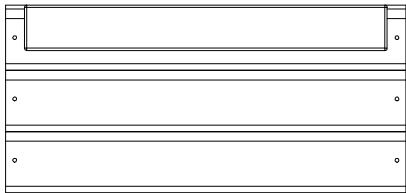

(2) WP6 - UPPER CENTER WALL
- W2A01510

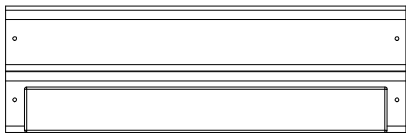

(2) WP5 - LOWER CENTER WALL
- W2A01509

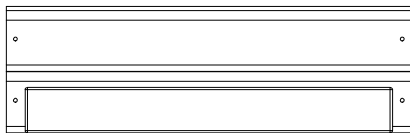

(1) WP8 - LOWER REAR CENTER WALL
- W2A01523

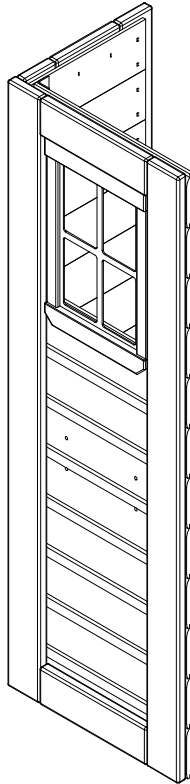

(1) WP1 - LEFT FRONT CORNER PANEL
- W2A01524

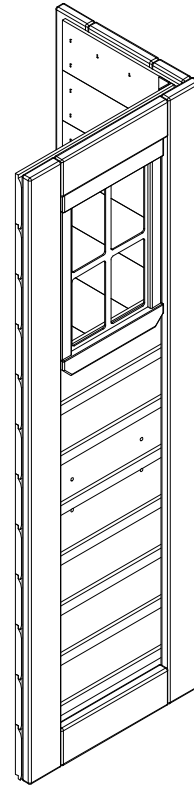

(1) WP2 - RIGHT FRONT CORNER PANEL
- W2A01525

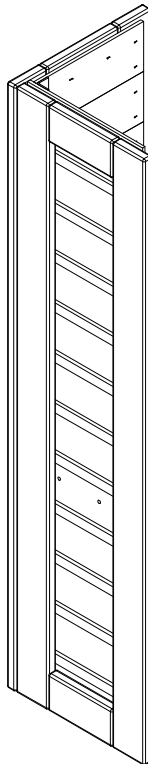

(1) WP3 - LEFT REAR CORNER PANEL
- W2A01526

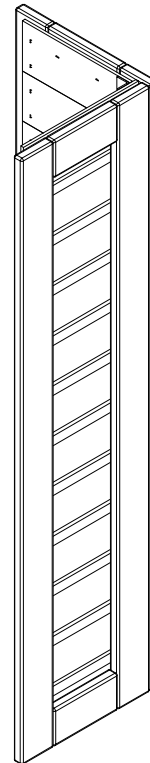

(1) WP4 - RIGHT REAR CORNER PANEL
- W2A01527

Parts Identification
Wood Components
(NOT TO SCALE)

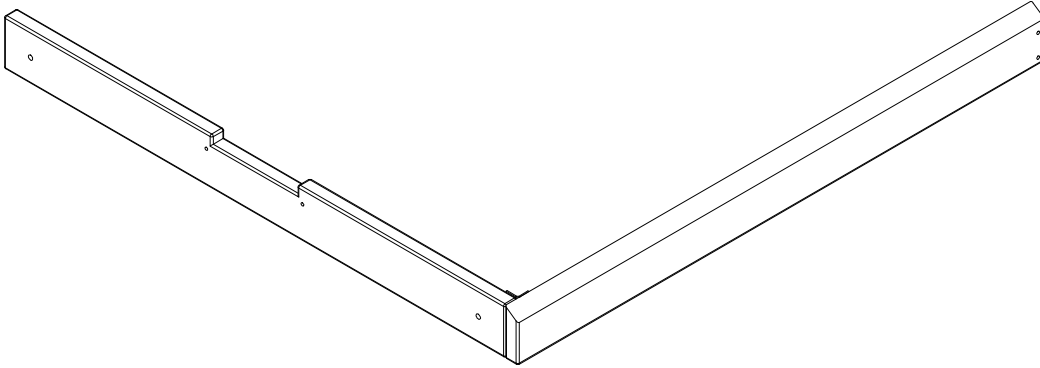

(2) WP9 - HEADER ASSEMBLY - W2A01539

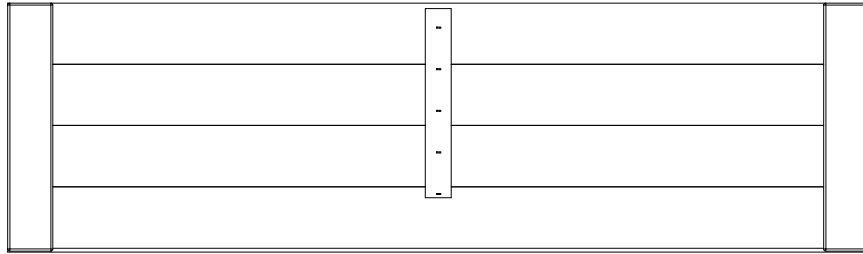

(2) RP1 - LOWER ROOF PANEL - W2A01513

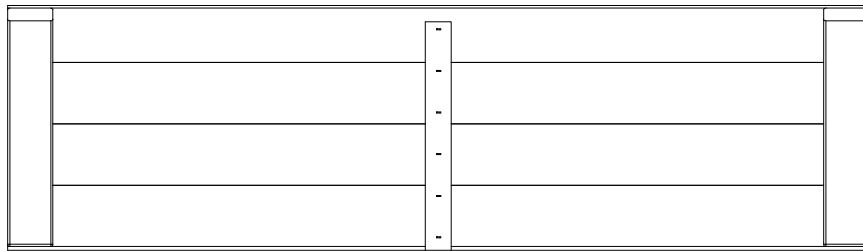

(2) RP2 - UPPER ROOF PANEL - W2A01514

Parts Identification

Hardware



(2) SCREW PFH 8x1/2 - H100124



(41) SCREW PFH 8x1 - H100085



(33) SCREW PFH 8x1 1/8 - H100088



(51) SCREW PFH 8x1 1/4 - H100087



(24) SCREW PFH 8x1 1/2 - H100086



(1) SCREW PFH 8x2 - H100111



(4) SCREW PFH 8x2 1/2 - H100090



(2) SCREW PWH 8x7/16 - H100361



(4) SCREW PWH 8x5/8 - H100128



(9) SCREW PWH 8x3/4 - H100070

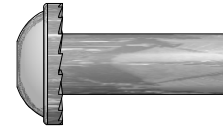

(4) NUT BARREL WH 1/4x7/8 - H100140

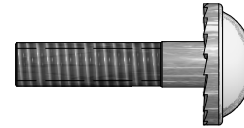

(4) BOLT WH 1/4x1 - H100137

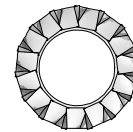

(4) WASHER LOCK EXT 8x15 - H100139

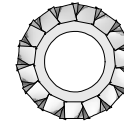

(4) WASHER LOCK EXT 6x15 - H100138

9220119
(1) TOOL KIT

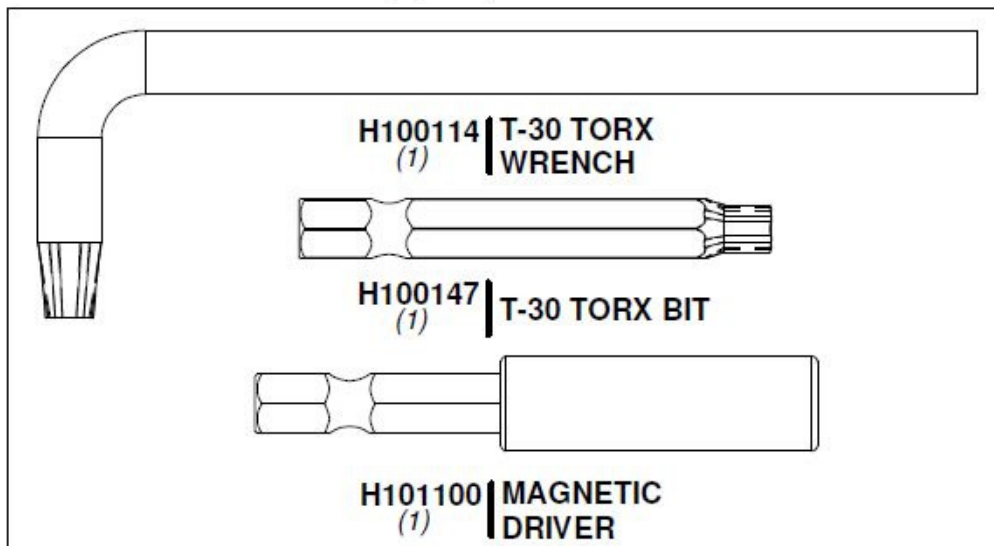

Parts Identification

Accessories

(NOT TO SCALE)



(1) PHONE KIT - A100132

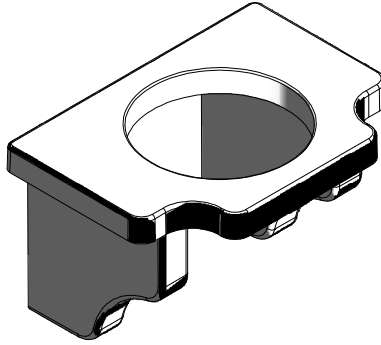

(2) FLOWER POT HOLDER - A6P00023

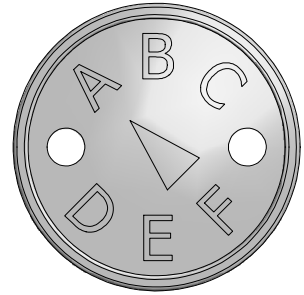

(1) "A" REVISION TAG - A100314

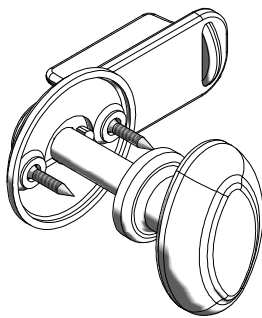

(1) KNOB KIT - A6P00020

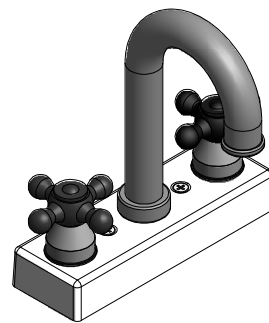

(1) FAUCET KIT - A6P00024

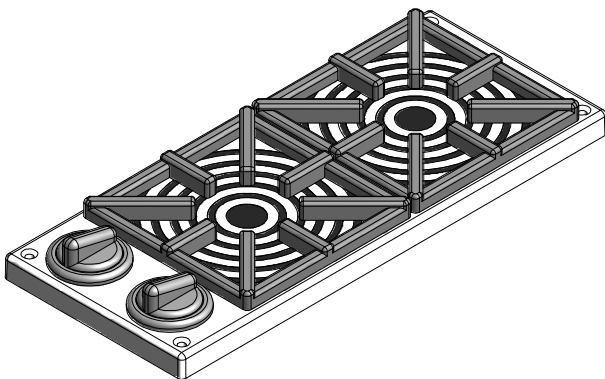

(1) STOVE KIT - A6P00025



(1) BYD ID TAG (MEDIUM) AGES 2 TO 10 - A4M00528

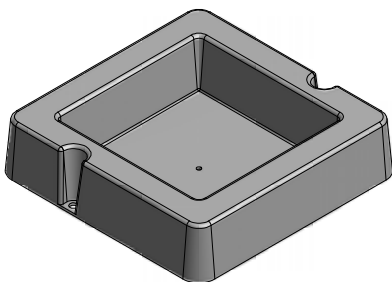

(1) SURFACE MOUNT BASIN - A6P00032

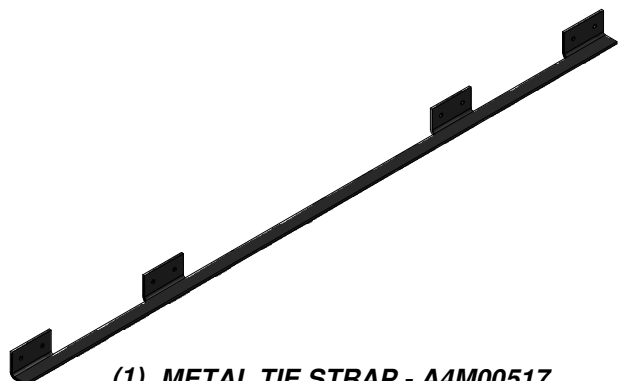

(1) METAL TIE STRAP - A4M00517

PRE-ASSEMBLY STEP 1 - SORTING PARTS

It is critical for ease of assembly that you take the time to sort and organize the wood and hardware.

WOOD PARTS:

- Organize wood parts by the three-digit, alpha-numeric number stamped on each board (ex. P01).
- If there are multiple boards with the same stamped number, stack those pieces together.
- Stamps can be found on the flat surface of the boards or on the end of the boards.
- Allow yourself plenty of room - the wood pieces can take up a significant amount of space.

NOTE: CARTONS ARE NOT ORGANIZED BY BOARD NUMBER.

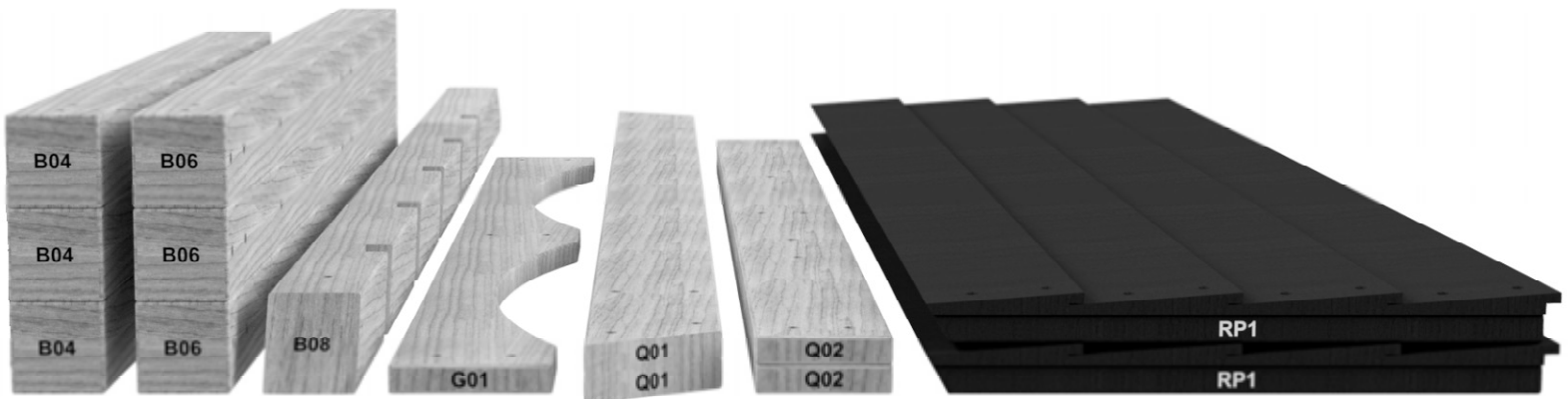

HARDWARE PARTS:

- We recommend that you have a separate table to organize the hardware.
- Hardware bags are printed with a seven-digit, alpha-numeric part number.
- You can organize your hardware by part number or group by hardware type (i.e. bolts, nuts, etc.).
- During assembly you only need to reference the last four digits of the number.

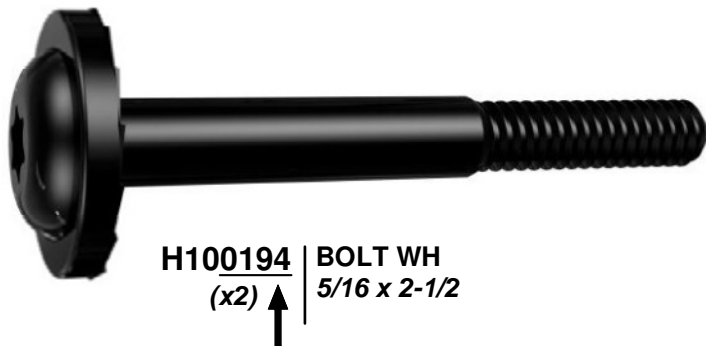

PRE-ASSEMBLY STEP 2 - TOOLS REQUIRED



**Cordless Drill or
Electric Drill**



**Drill Attachments:
Phillips Head**



**1/8", 3/16", 3/8" & 7/16"
Drill Bits**



Phillips Screw Driver



Open End Wrenches 1/2" & 9/16"



**3/8" Drive Ratchet, 1/2" &
9/16" STD Sockets 1/2" & 9/16" Deep
Sockets**



Claw Hammer



Rubber Mallet - Optional



Tape Measure

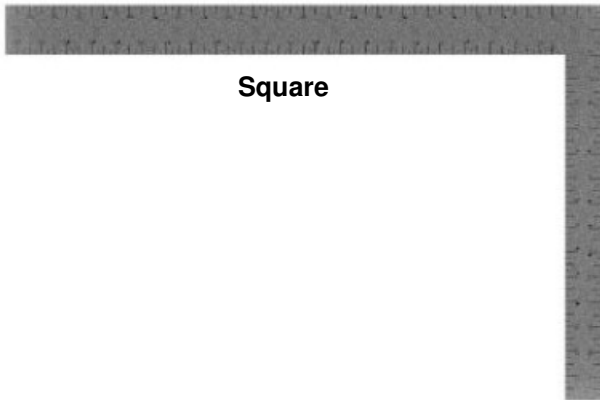

Square



Level 24"

PRE-ASSEMBLY STEP 3 - CHOOSE YOUR ASSEMBLY METHOD

There are several types of assembly instructions available to you.

1. Printed Assembly Manual included with your set
2. BILT APP - 3D interactive instructions
3. Combination of the Printed Manual and BILT APP (Note: Step numbers can differ between the two methods)

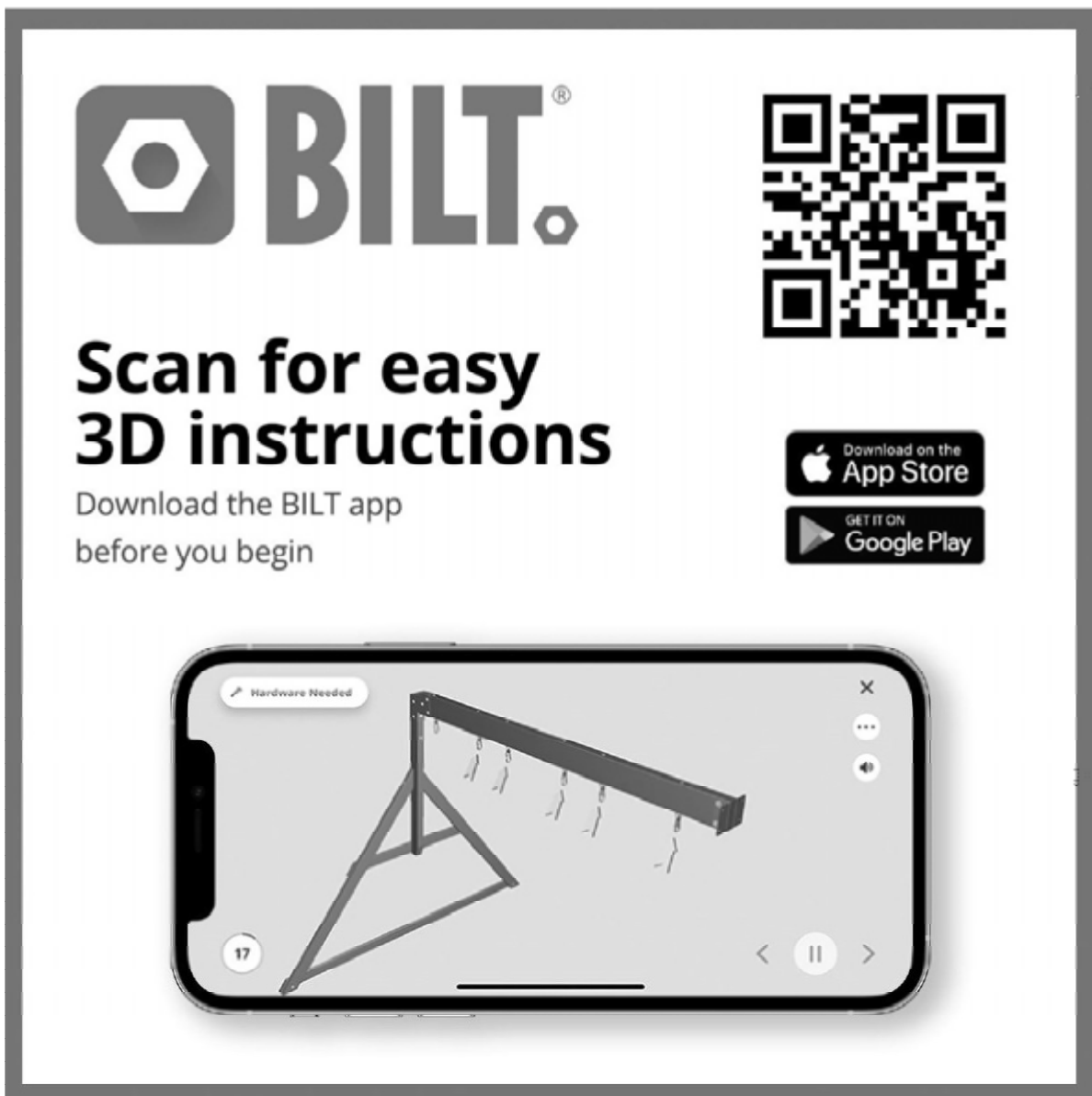

BILT.[®]

Scan for easy
3D instructions

Download the BILT app
before you begin

Download on the
App Store

GET IT ON
Google Play

Hardware Needed

17

< || >

Playhouse Assembly

STEP 1:
STAND THE (4) CORNER WALL ASSEMBLIES AS SHOWN BELOW.

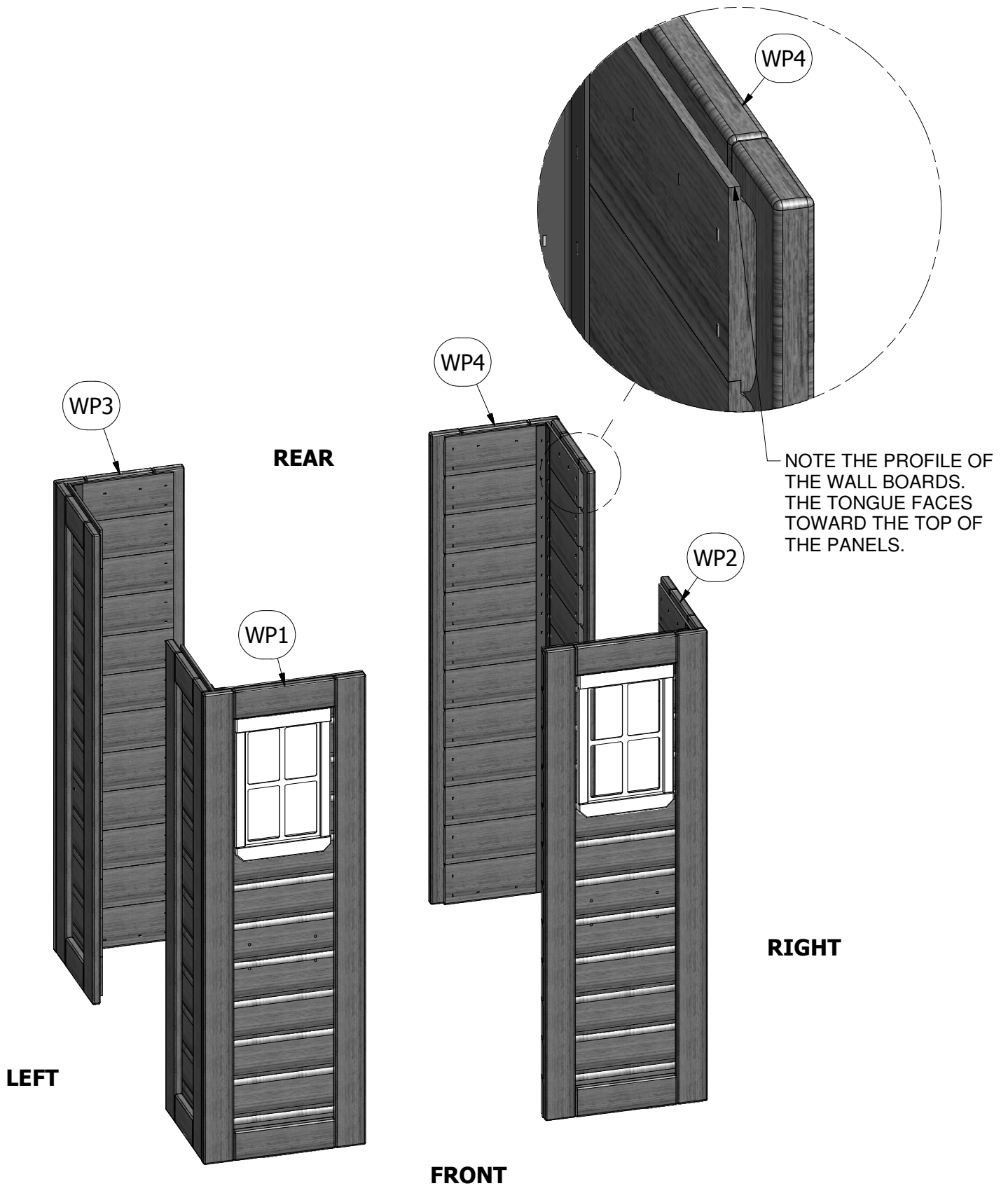

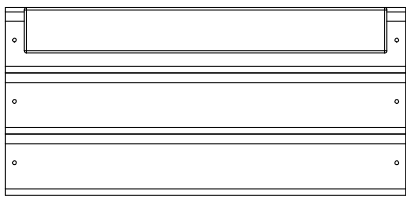

(1) WP6 - UPPER CENTER WALL
- W2A01510

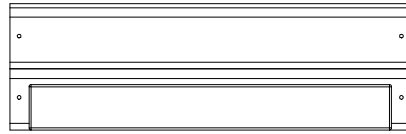

(1) WP5 - LOWER CENTER WALL
- W2A01509

STEP 2:

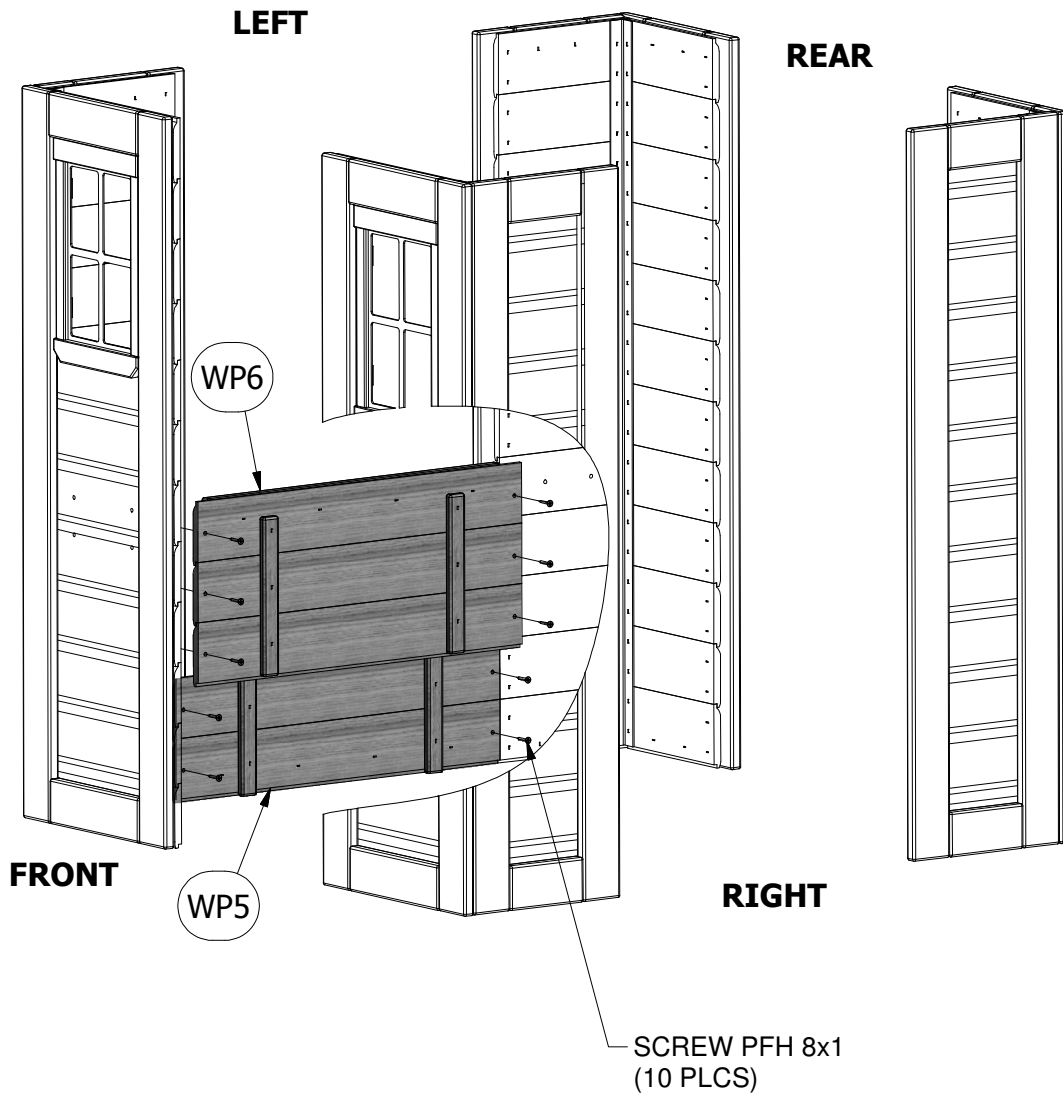
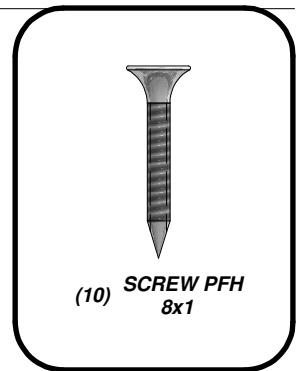

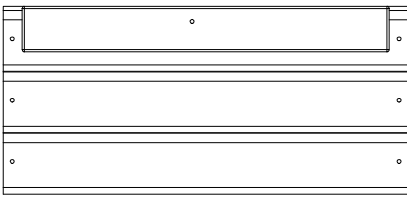

(1) WP7 - UPPER REAR CENTER WALL
- W2A01522

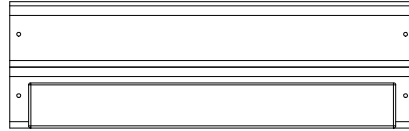

(1) WP8 - LOWER REAR CENTER WALL
- W2A01523

STEP 3:

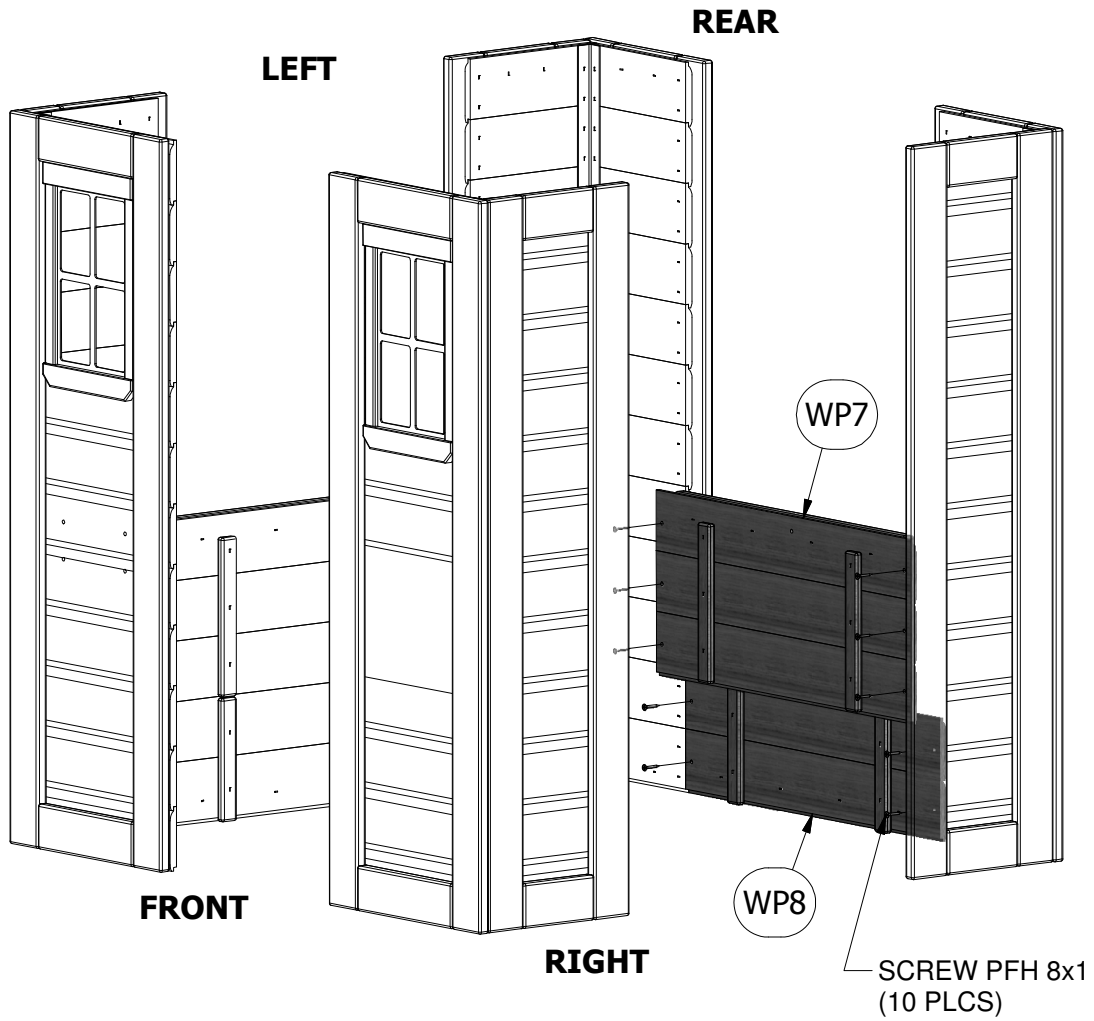
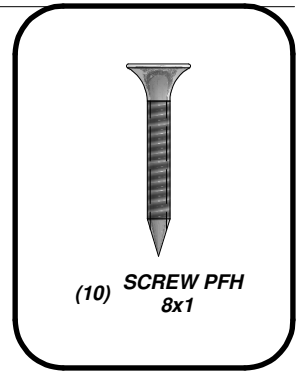

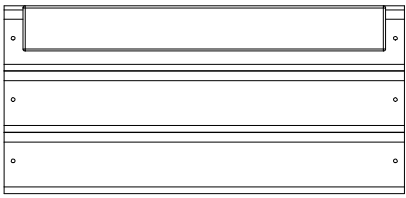

(1) WP6 - UPPER CENTER WALL
- W2A01510

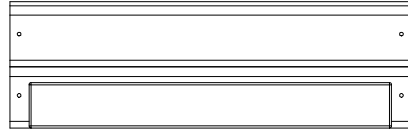

(1) WP5 - LOWER CENTER WALL
- W2A01509

STEP 4:

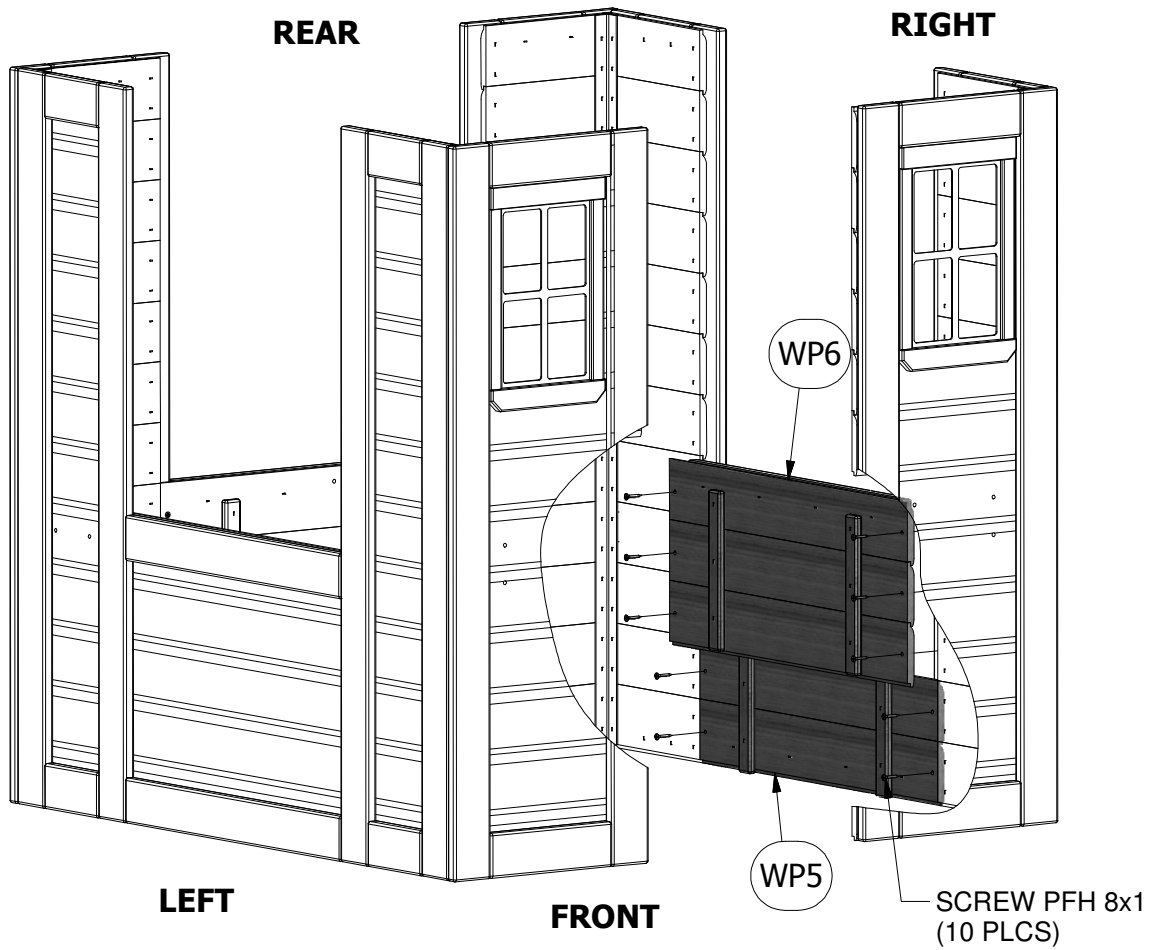
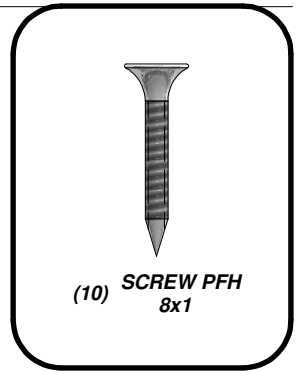

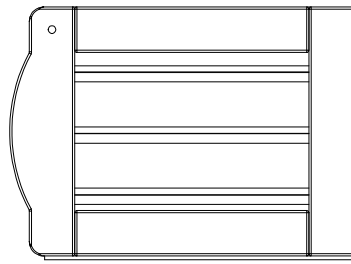

(1) DP1 - DOOR ASSEMBLY - W2A01511

STEP 5:

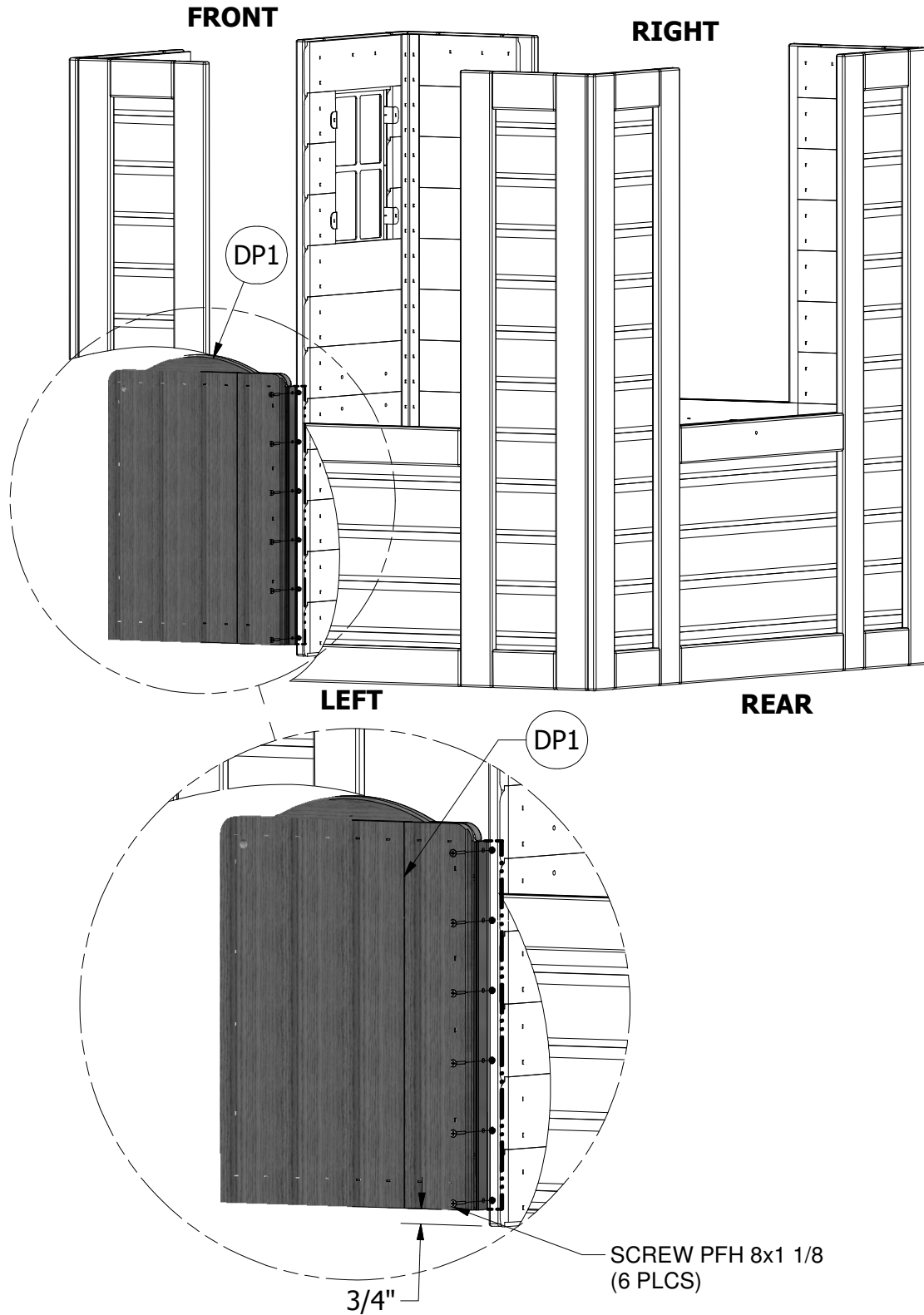
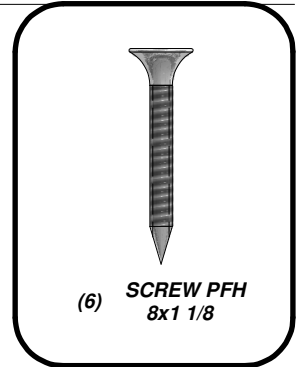



(1) METAL TIE STRAP - A4M00517

STEP 6:

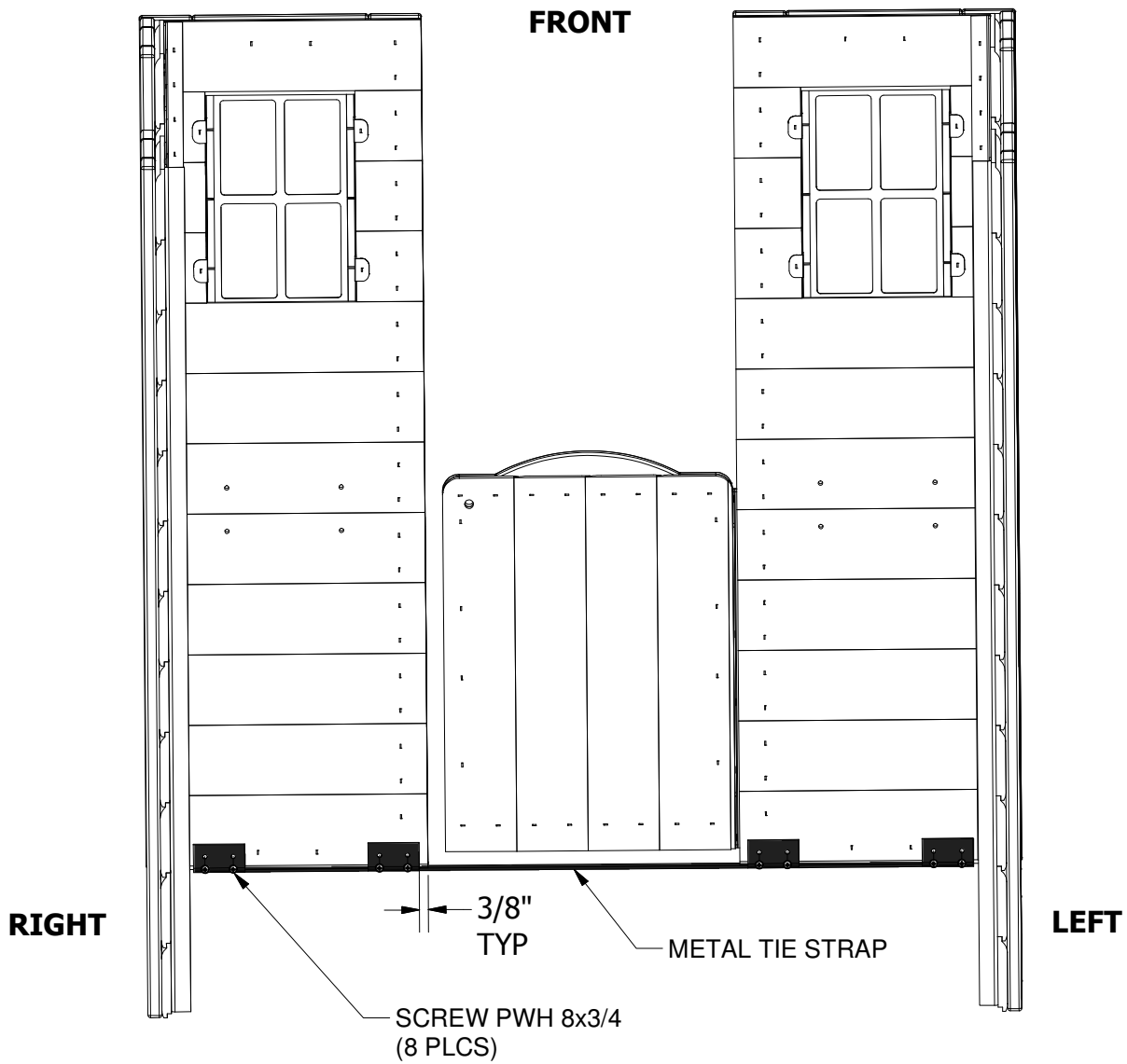
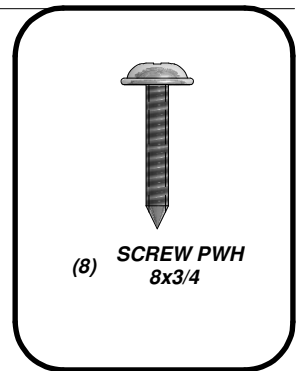

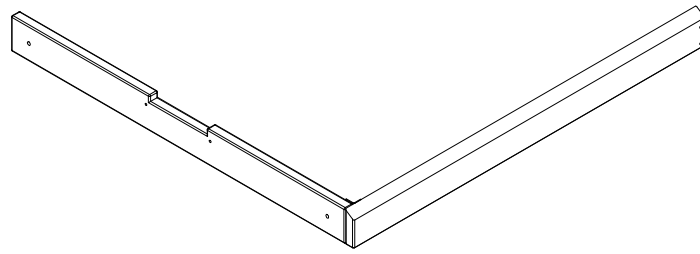

(2) WP9 - HEADER ASSEMBLY - W2A01512

STEP 7:

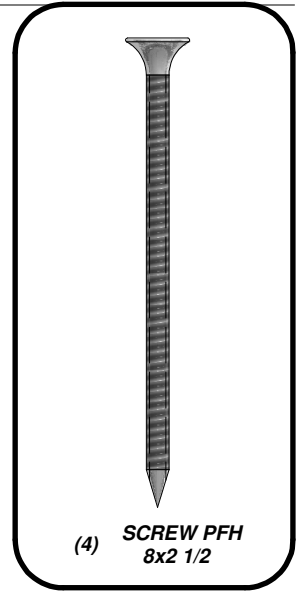
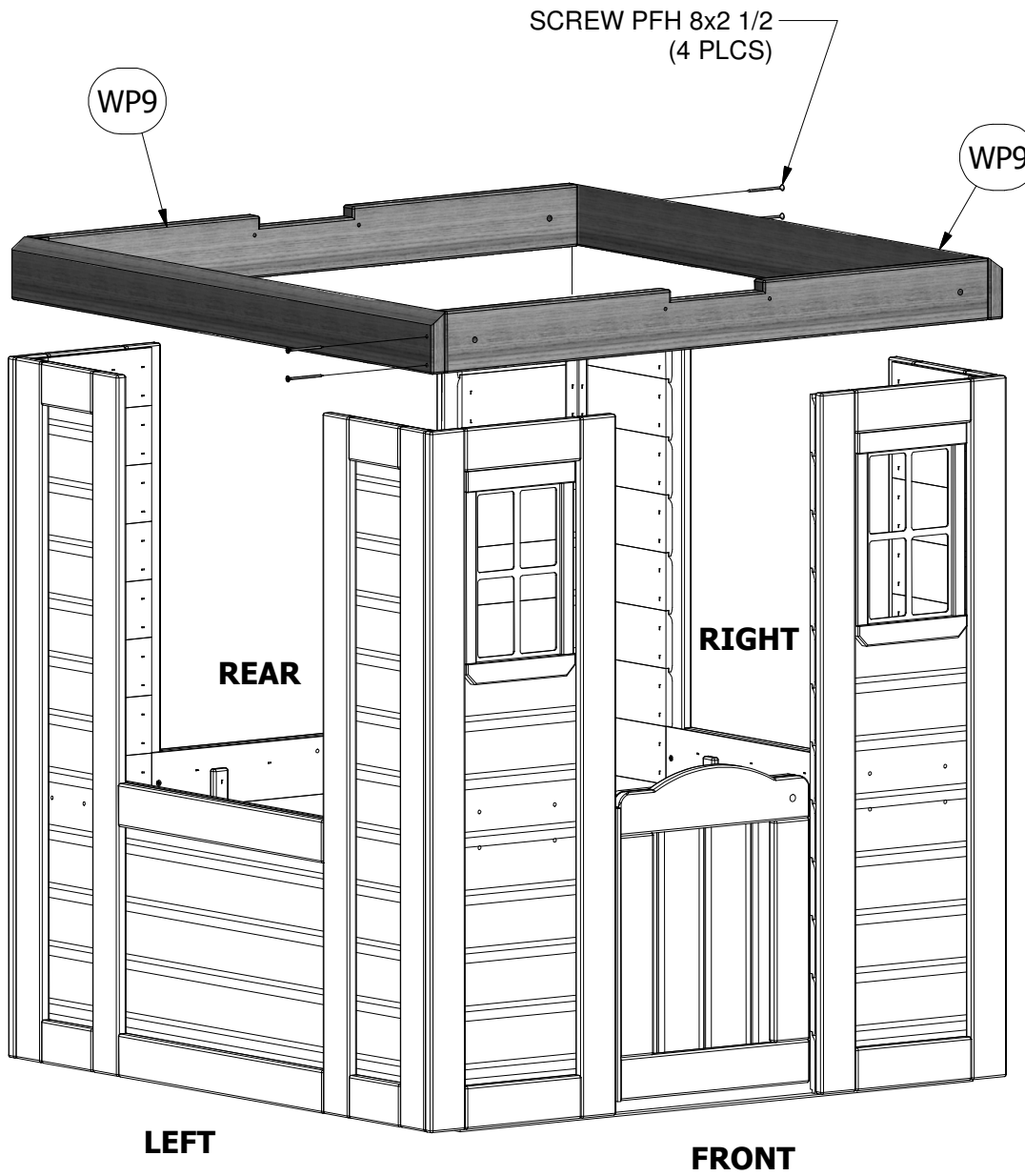

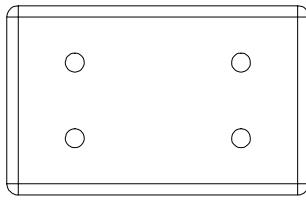

(8) **N4 - TIE STRAP - W102424**
5/8"x2"x3 1/8" (16x50x80)

STEP 8:

SCREW PFH 8x1 1/4
(32 PLCS)

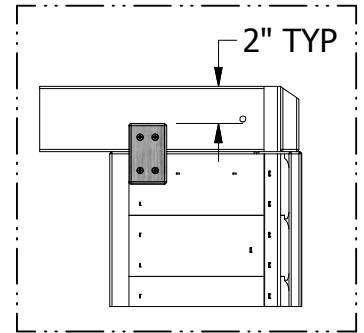
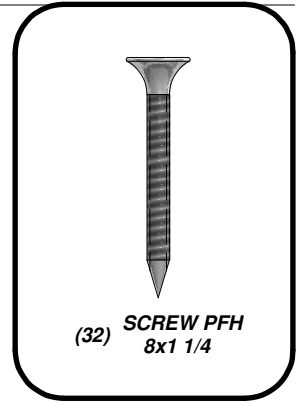
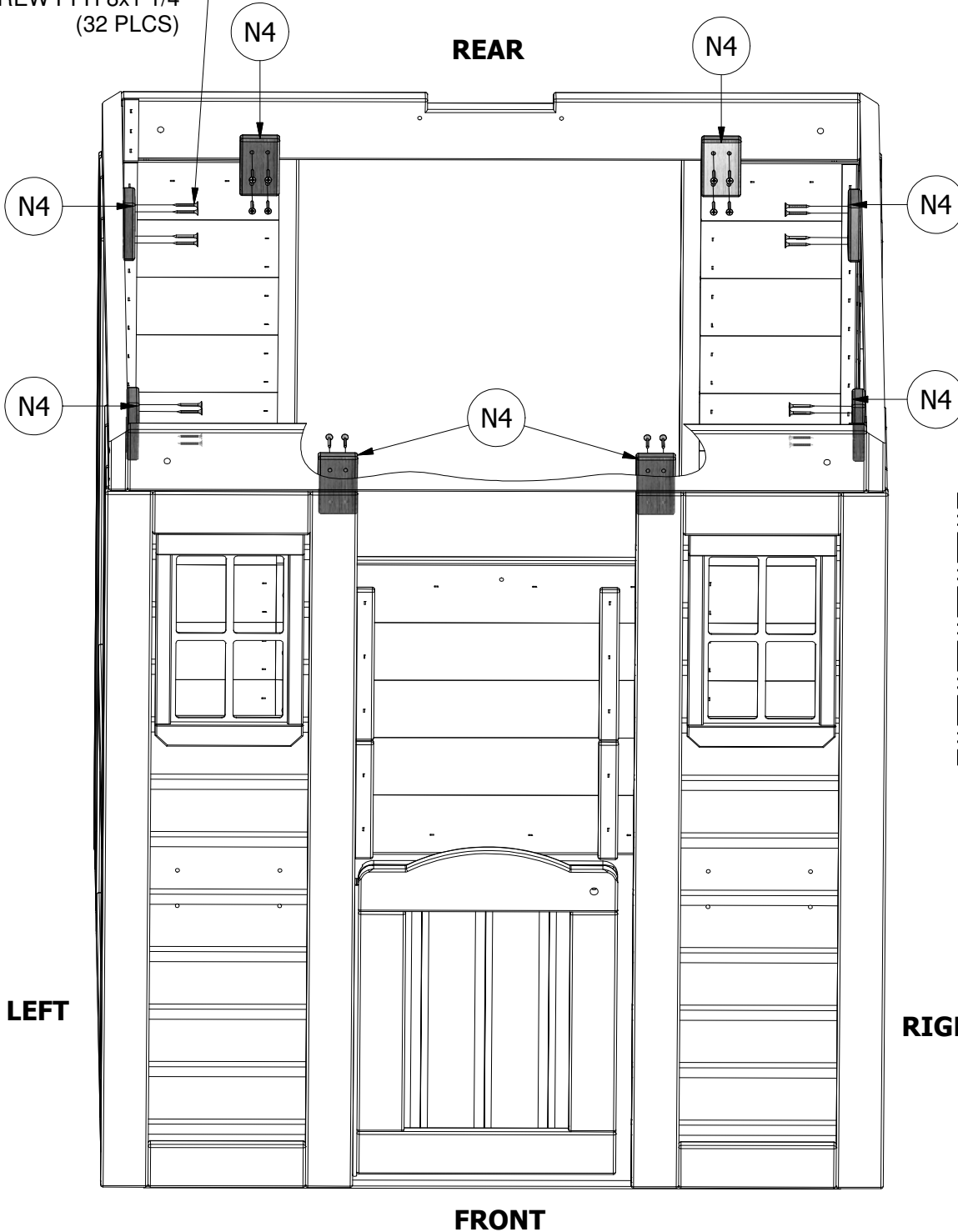

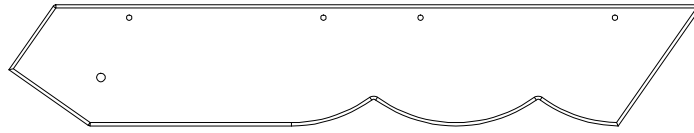

(4) **L1 - GABLE BOARD - W4L04755**
 5/8"x4 3/8"x25 3/8" (16x112x643)

STEP 9:

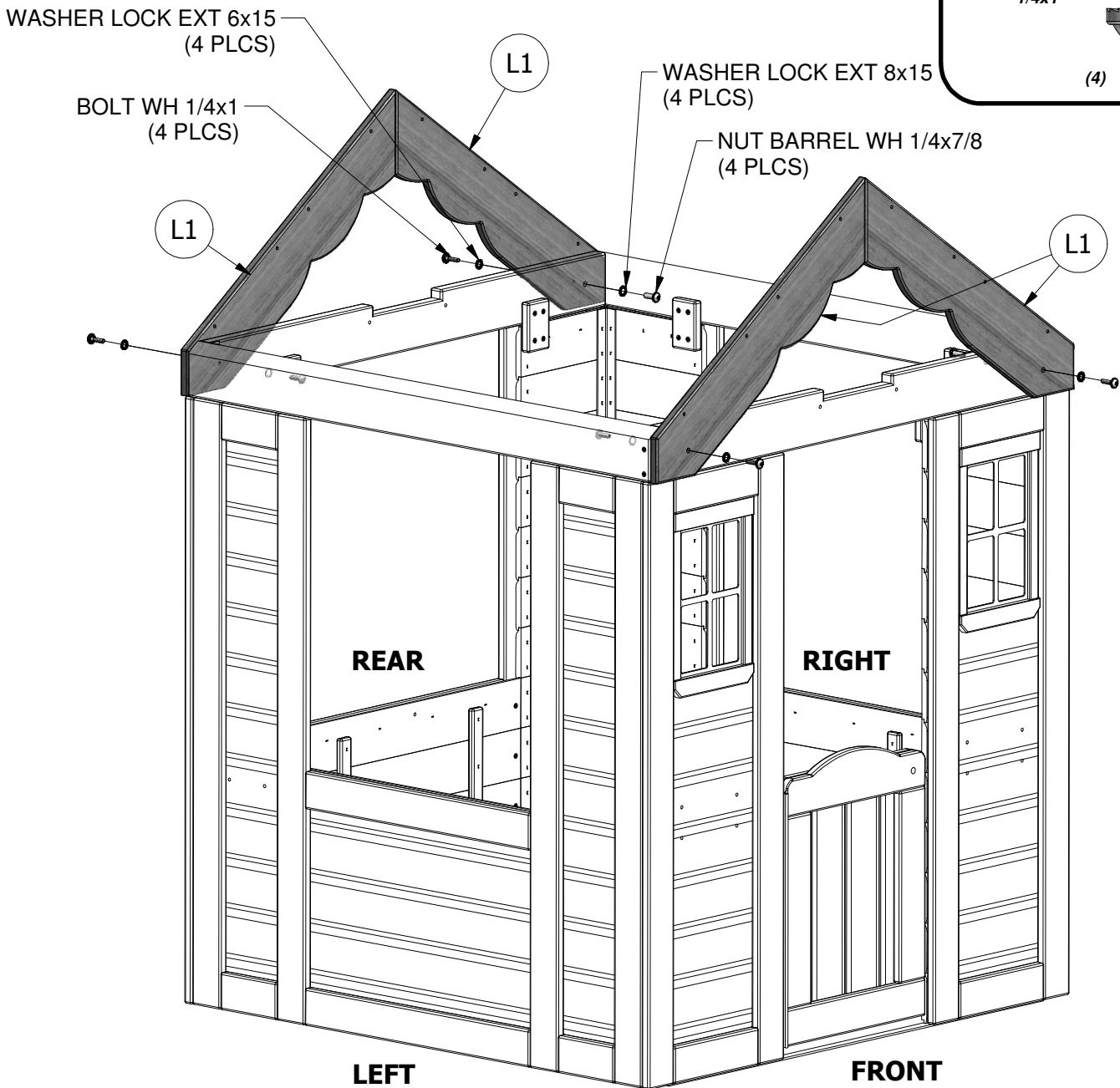
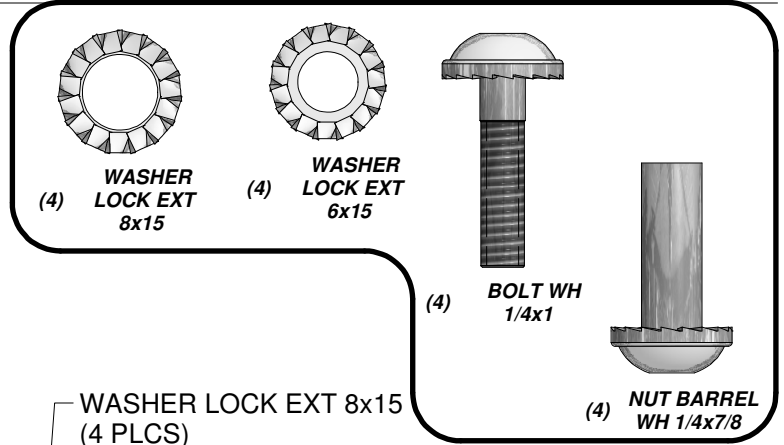

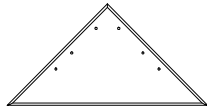

(2) **K1 - TRIANGLE SUNBURST - W4L04871**
 5/8"x5 1/4"x10 3/8" (16x134x265)



(2) **N5 - SUNBURST LEG - W4L04872**
 5/8"x2 3/8"x10 1/4" (16x60x260)



(4) **N6 - SUNBURST LEG - W4L04873**
 5/8"x2 3/8"x8 1/4" (16x60x210)

STEP 10:

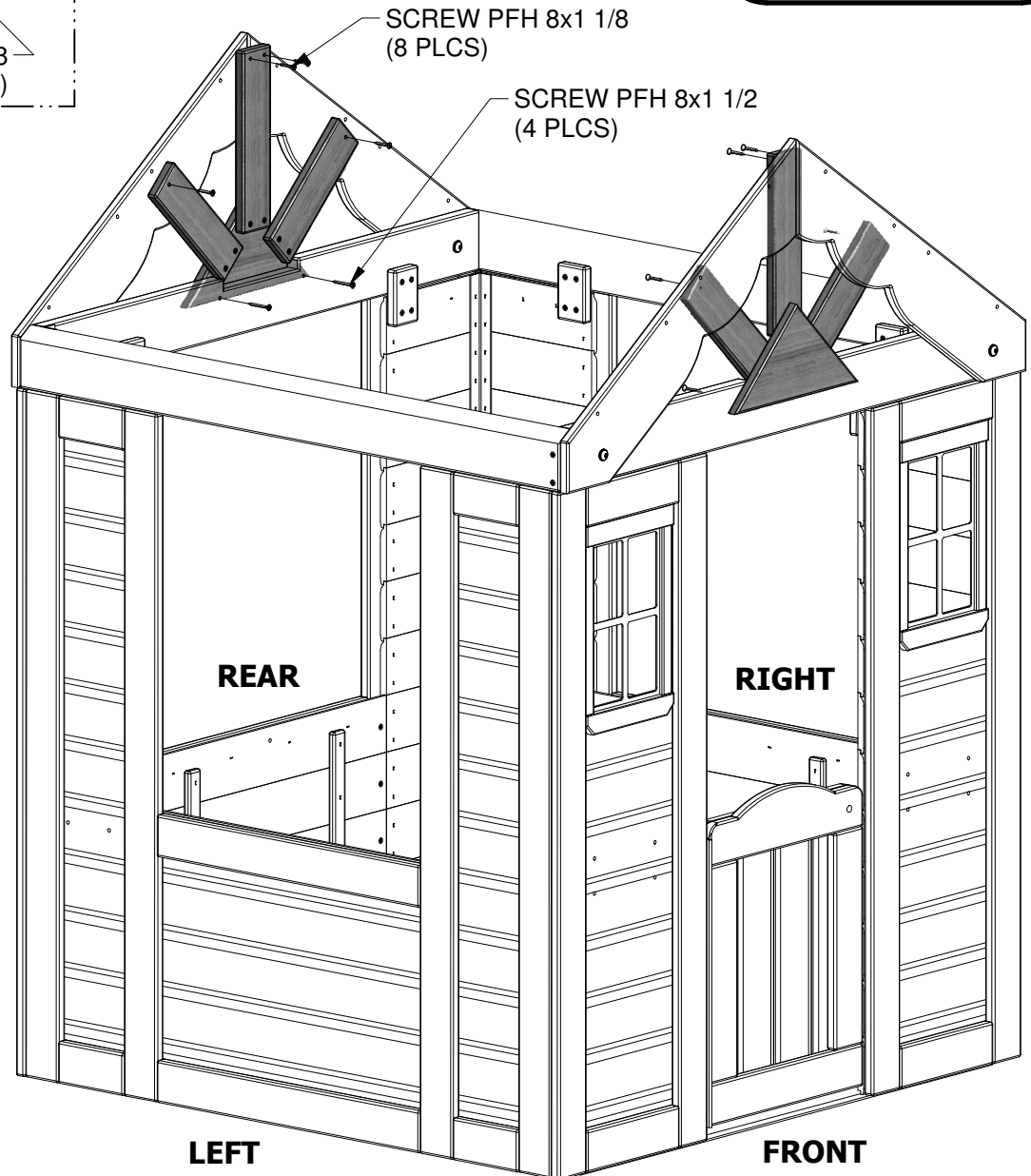
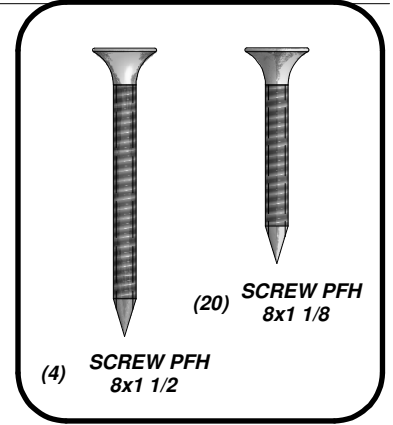
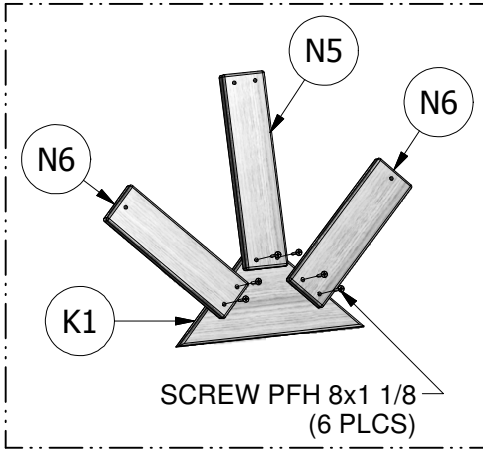

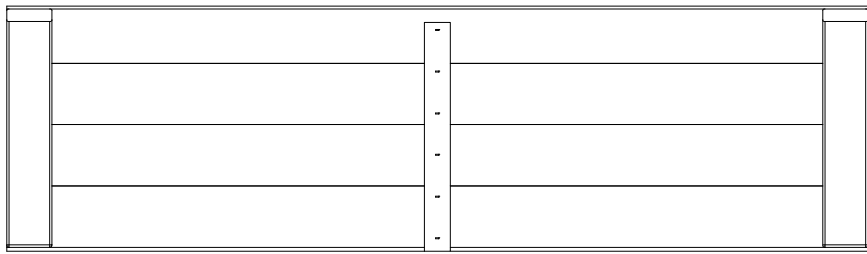

(2) RP2 - UPPER ROOF PANEL - W2A01514

STEP 11:

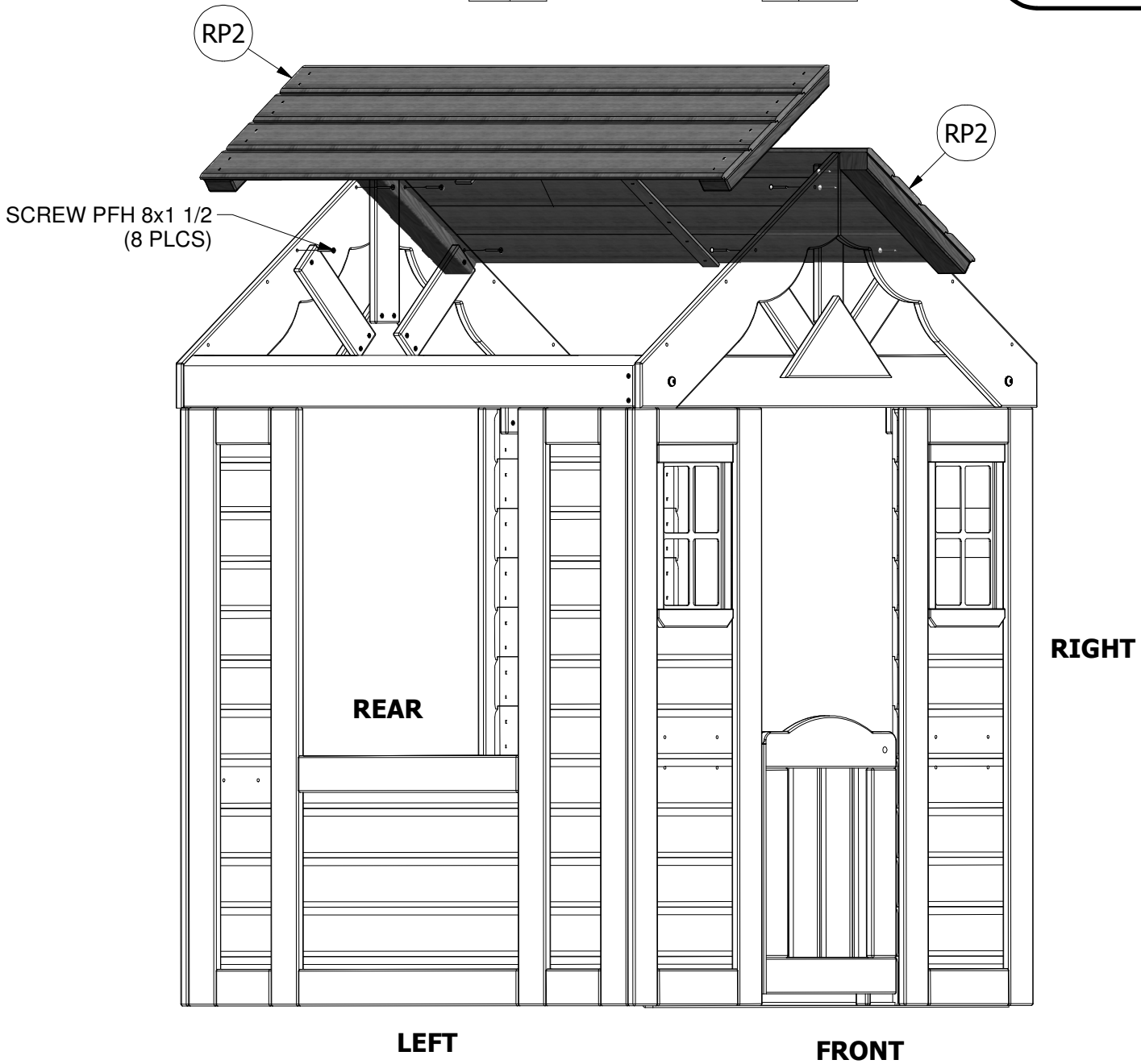
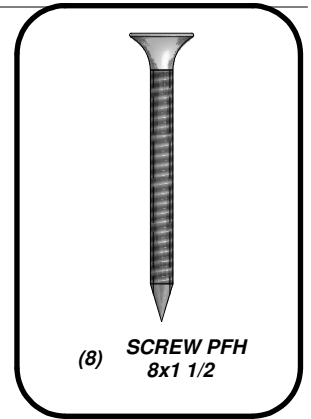
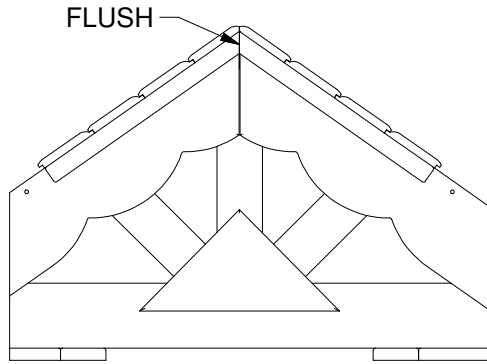

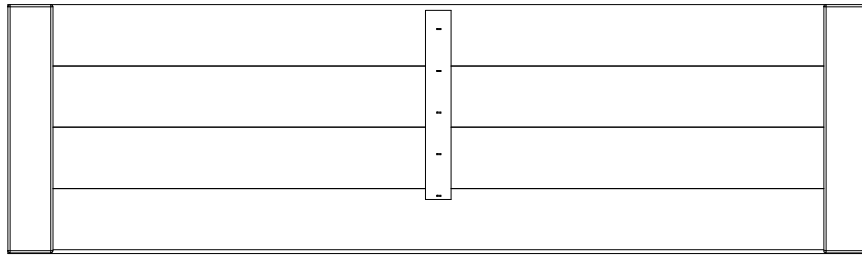

(2) RP1 - LOWER ROOF PANEL - W2A01513

STEP 12:

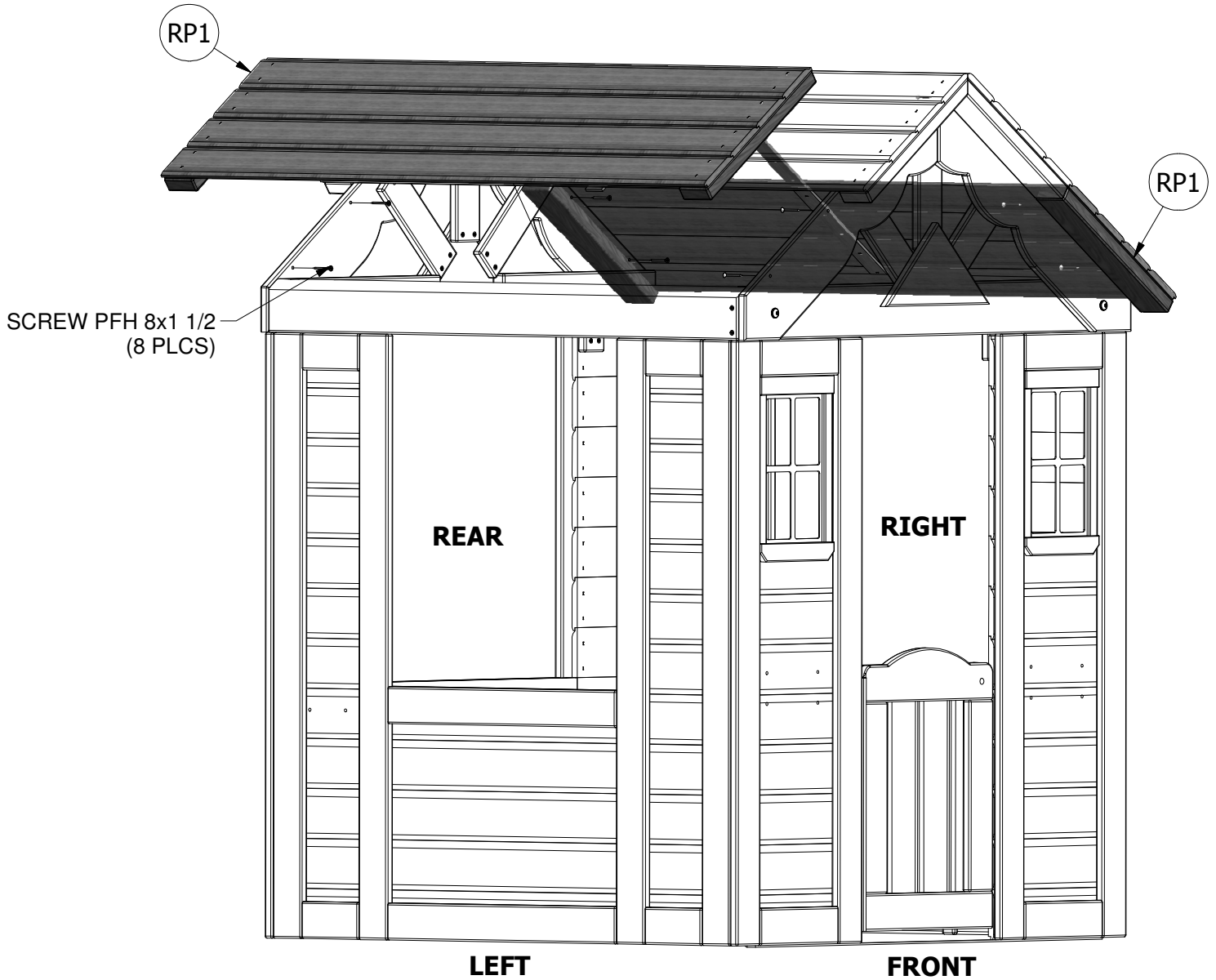
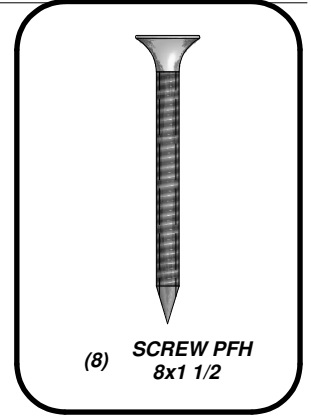

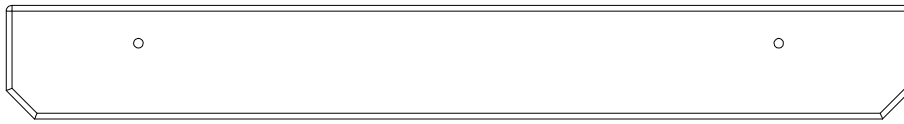

(1) **N1 - SIDE WINDOW SHELF - W4L04751**
5/8"x2 3/8"x18 7/8" (16x60x479)

STEP 13:

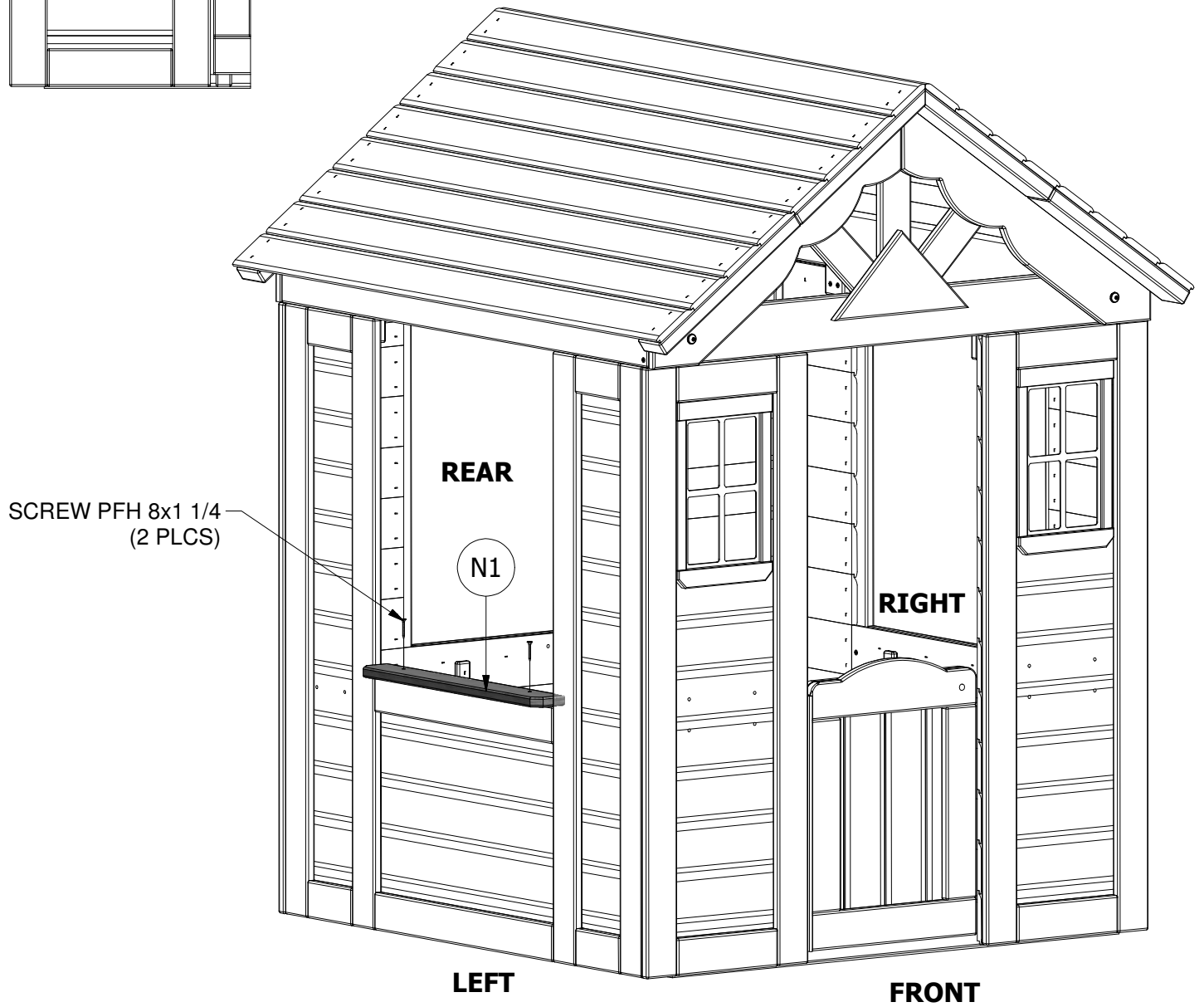
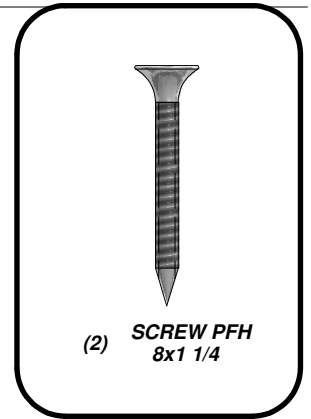
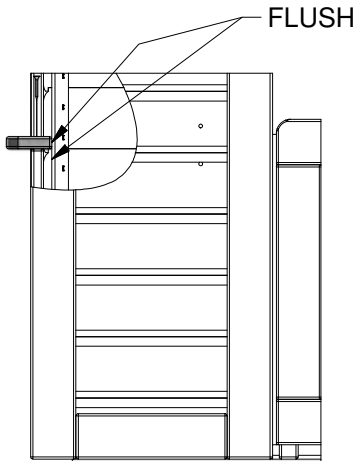

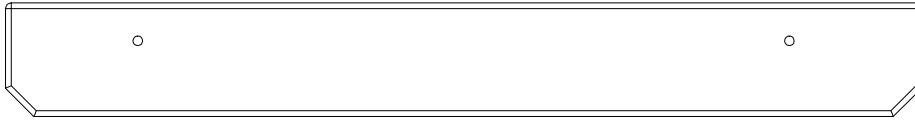

(1) **N2 - REAR WINDOW SHELF - W4L04760**
5/8"x2 3/8"x19 1/8" (16x60x485)

STEP 14:

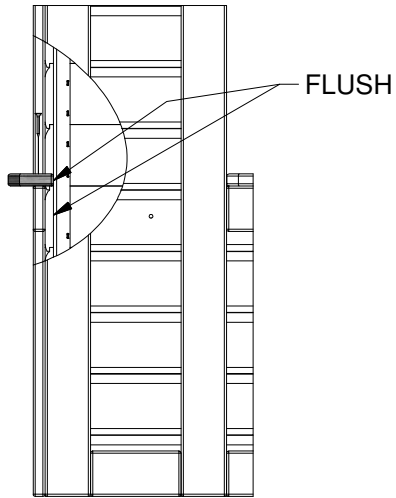

FLUSH

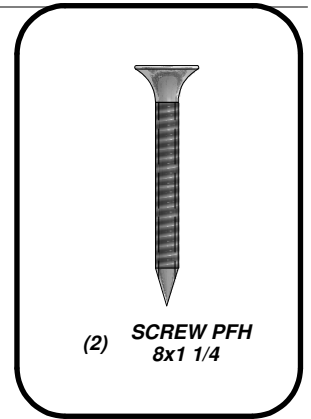

(2) **SCREW PFH**
8x1 1/4

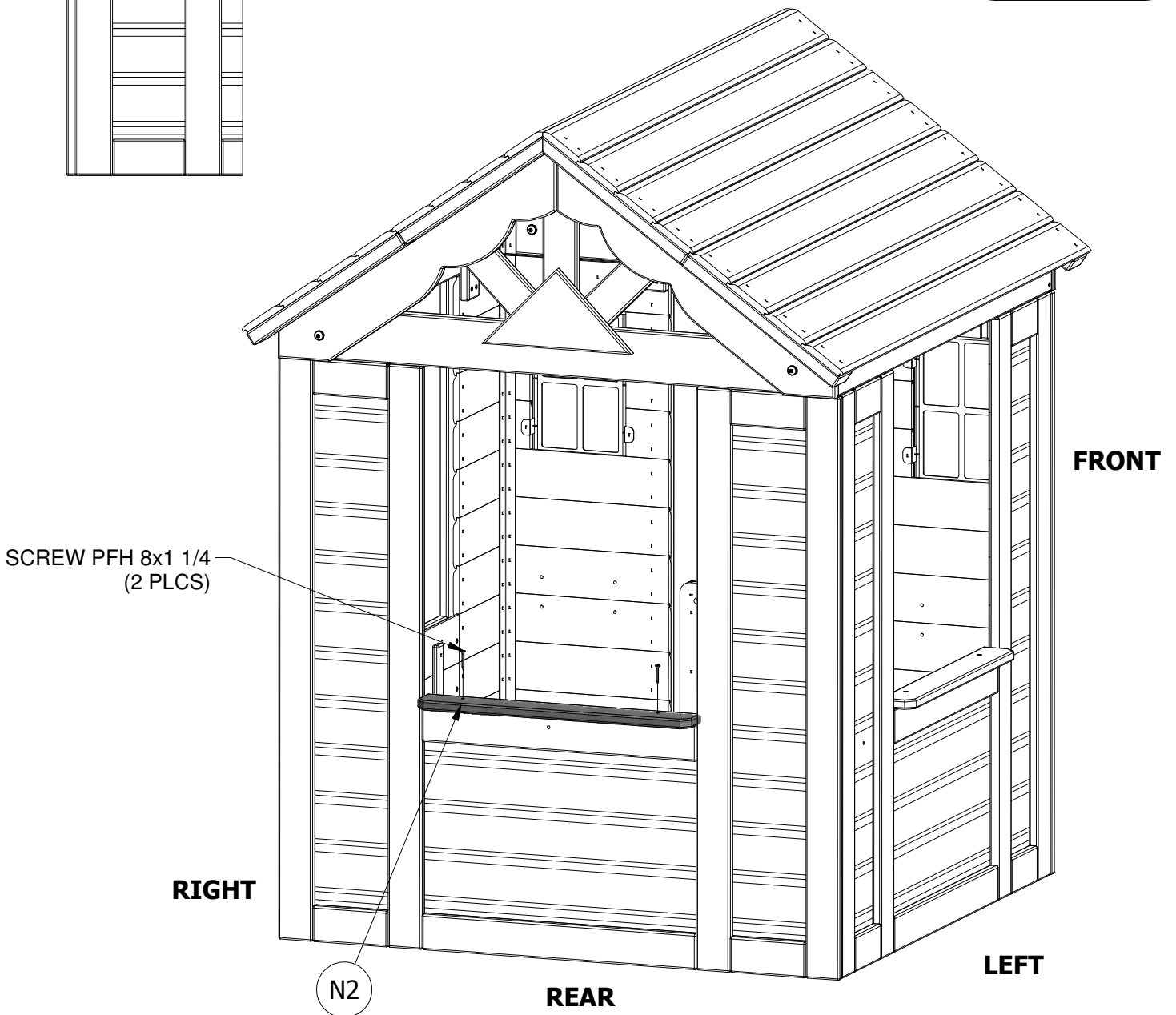



(1) **N1 - SIDE WINDOW SHELF - W4L04751**
5/8"x2 3/8"x18 7/8" (16x60x479)

STEP 15:

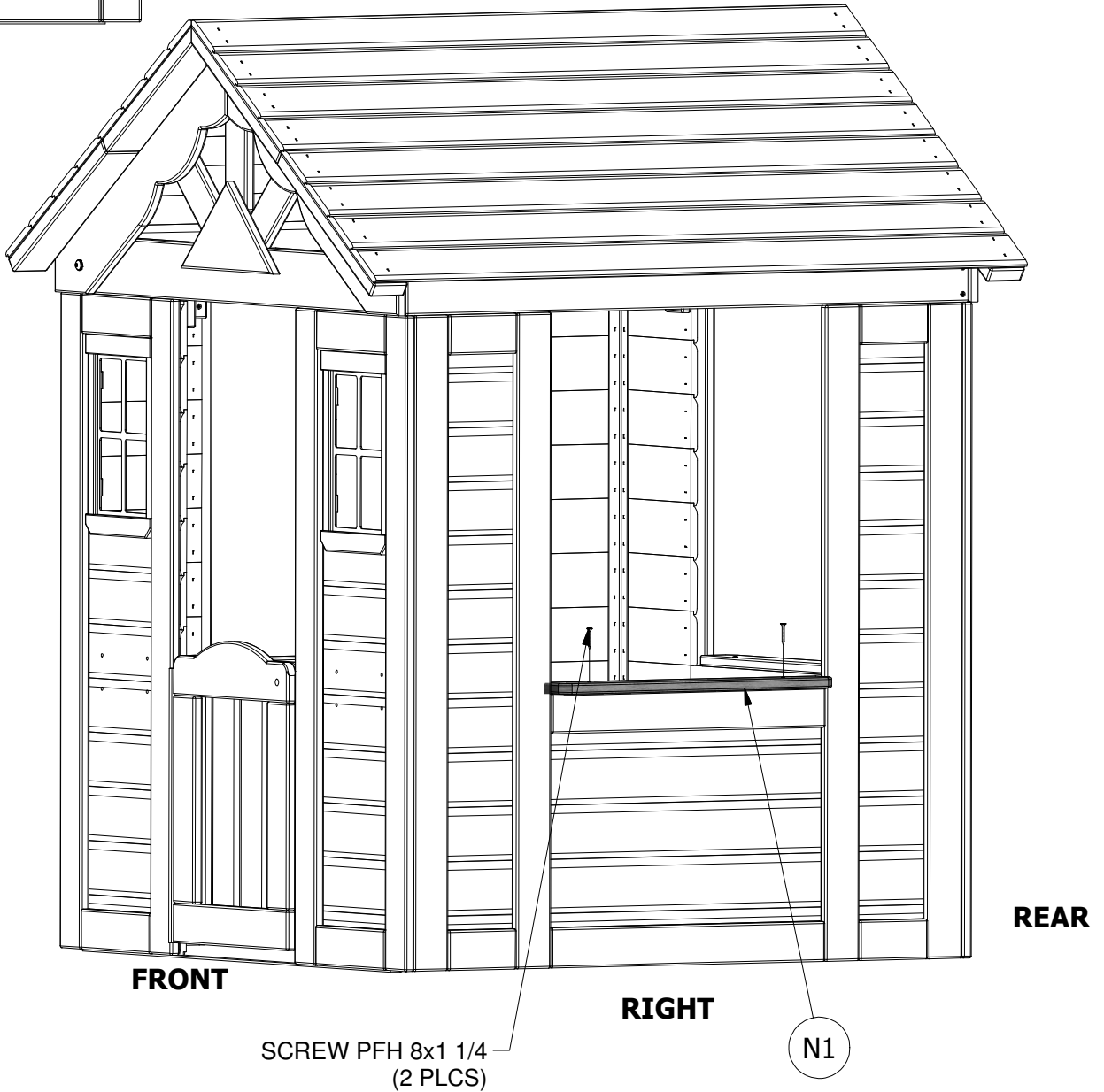
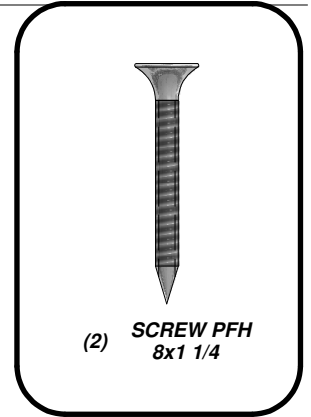
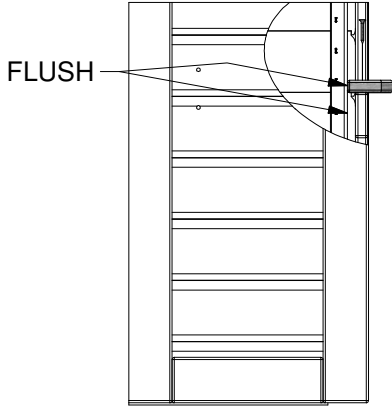

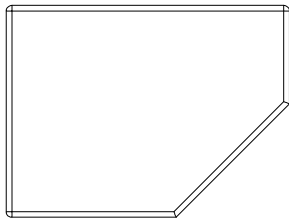

(1) **Q1 - COUNTER TOP SUPPORT - W4L04752**
1"x4 3/8"x5 7/8" (24x112x150)

STEP 16:

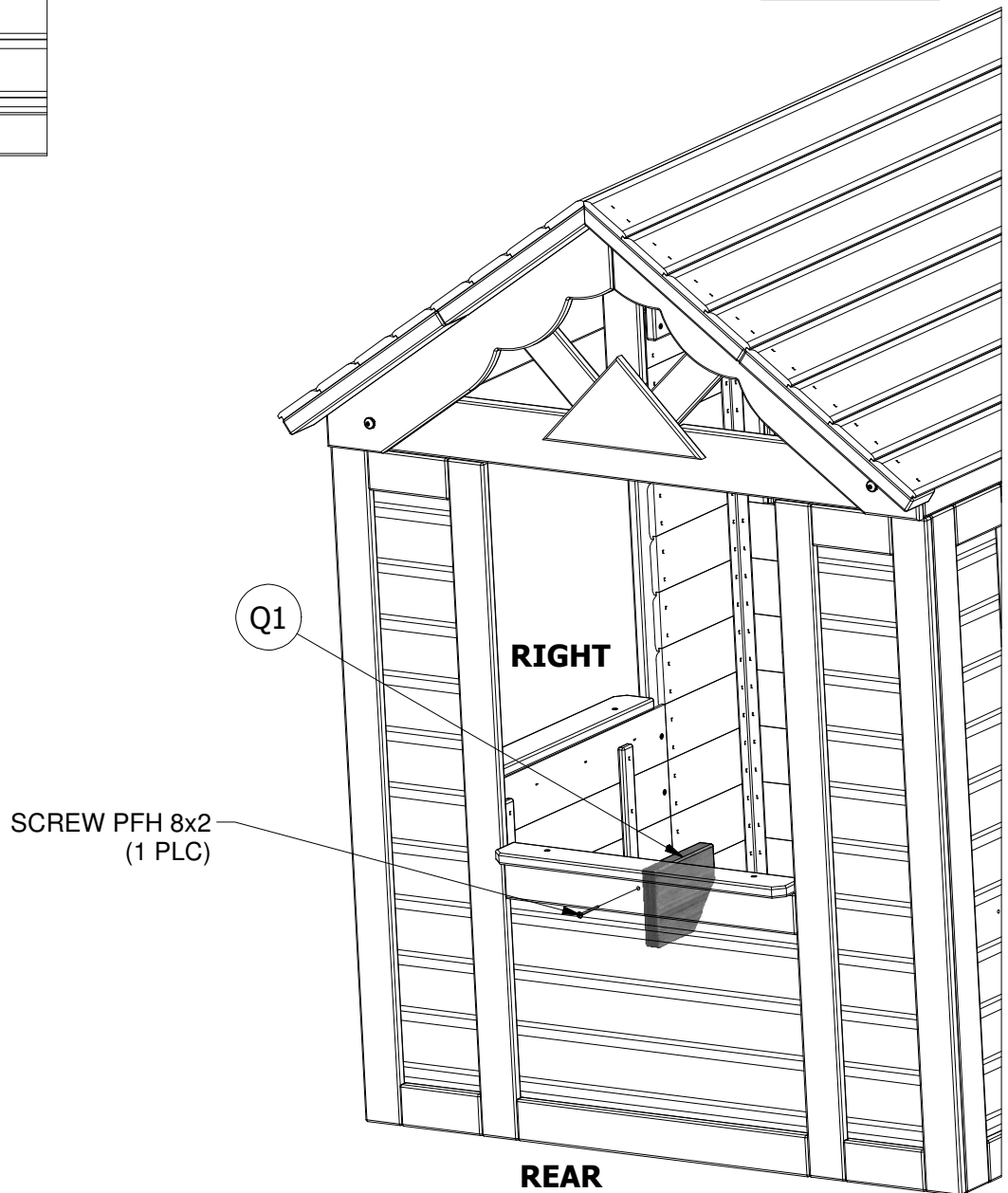
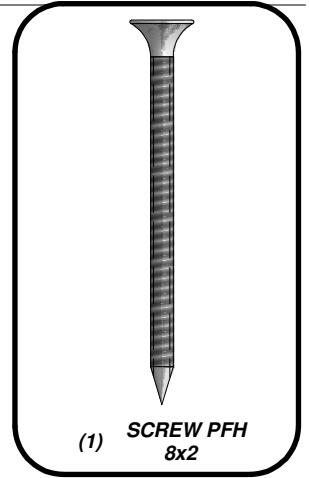
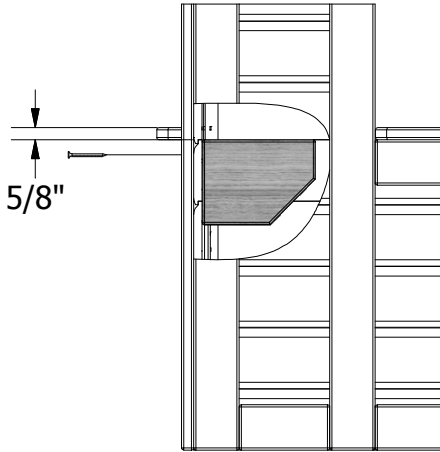

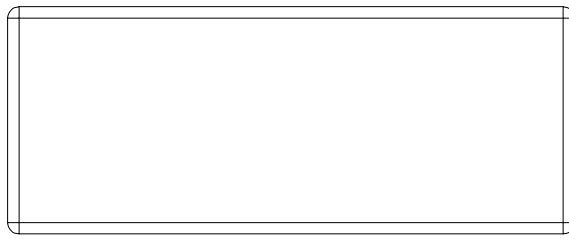

(1) **J1 - COUNTER TOP SUPPORT - W4L04753**
1"x2 3/8"x5 7/8" (24x60x150)

STEP 17:

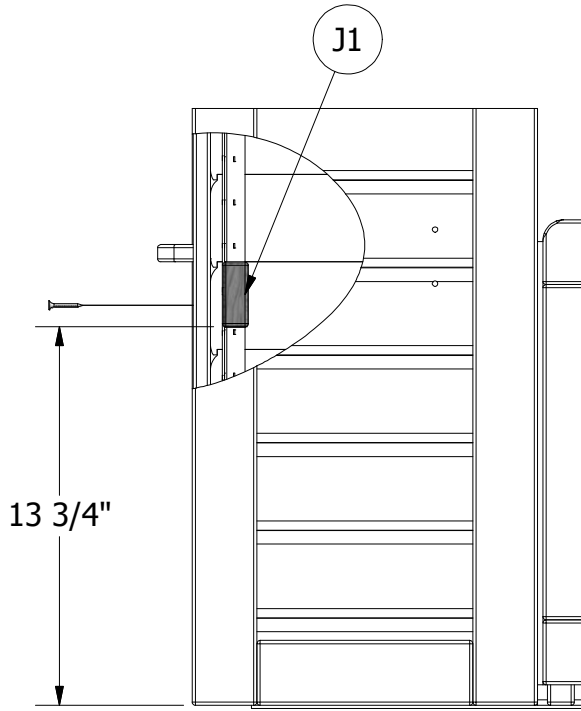

FRONT

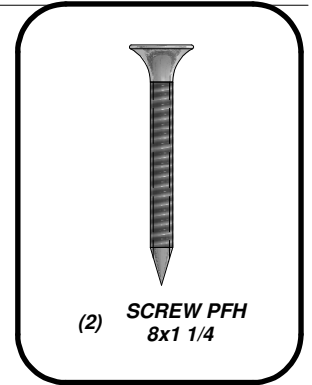

(2) **SCREW PFH**
8x1 1/4

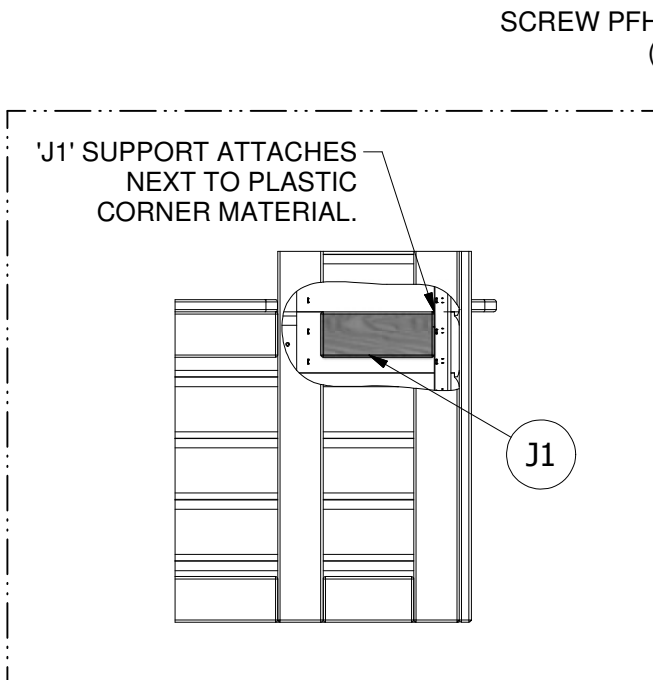

SCREW PFH 8x1 1/4
(2 PLCS)

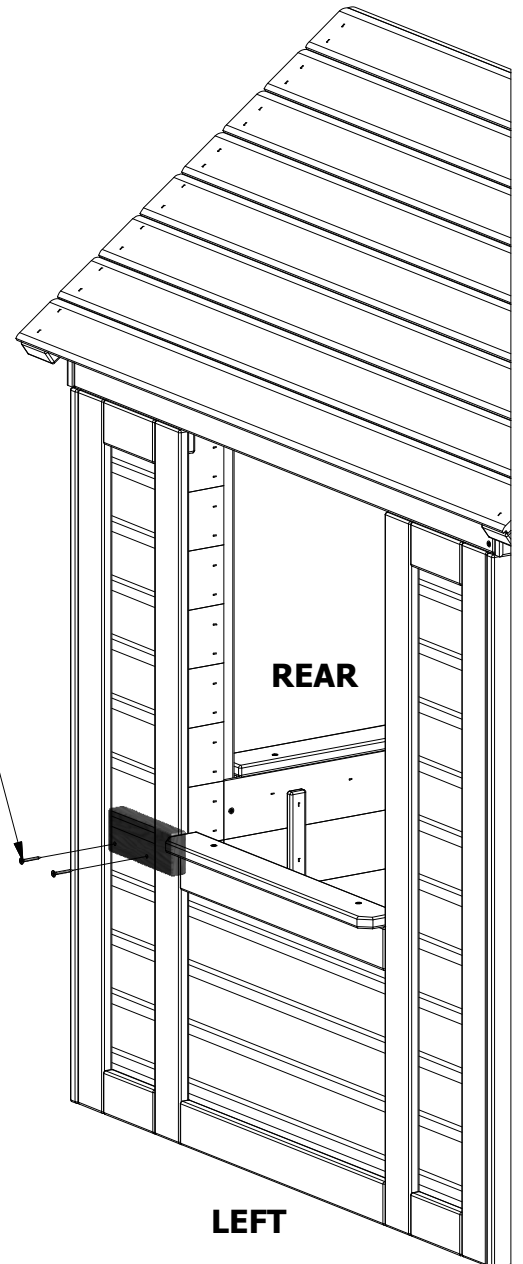

REAR

LEFT

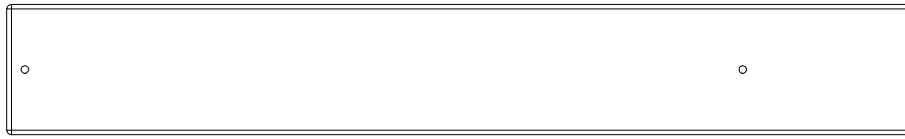

(2) **M1 - COUNTER TOP - W4L04754**
5/8"x3 3/8"x23 5/8" (16x86x600)

STEP 18:

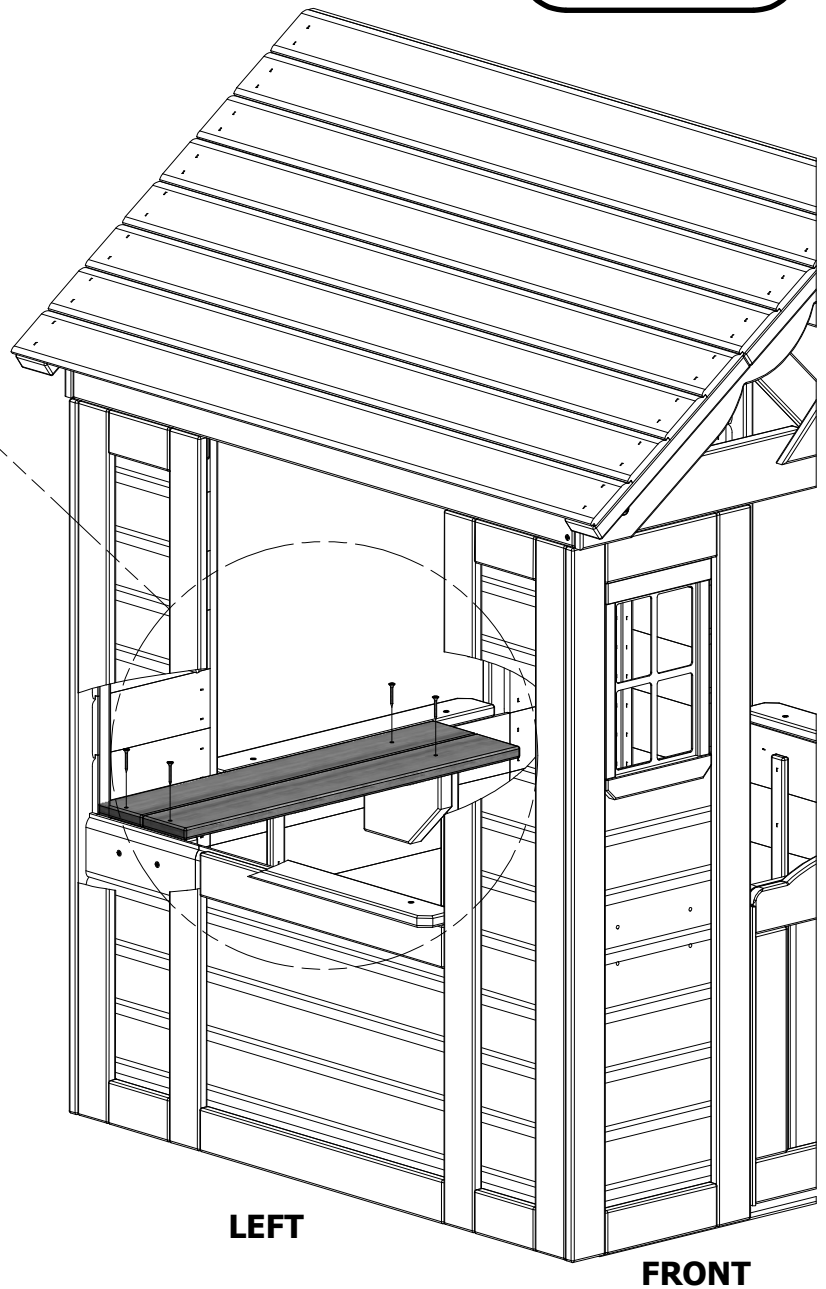
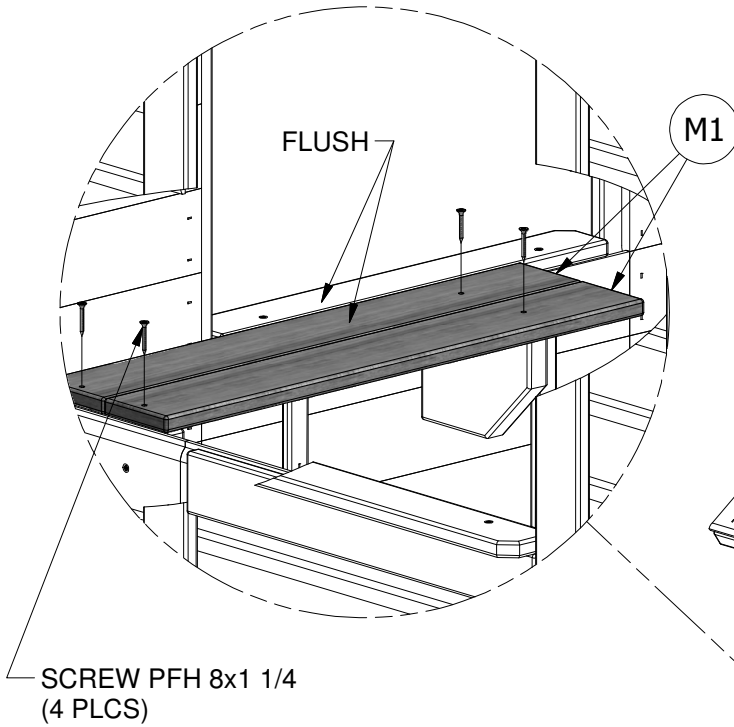
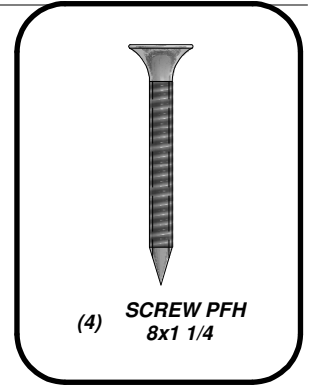

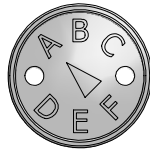

(1) "A" REVISION TAG - A100314

STEP 19:

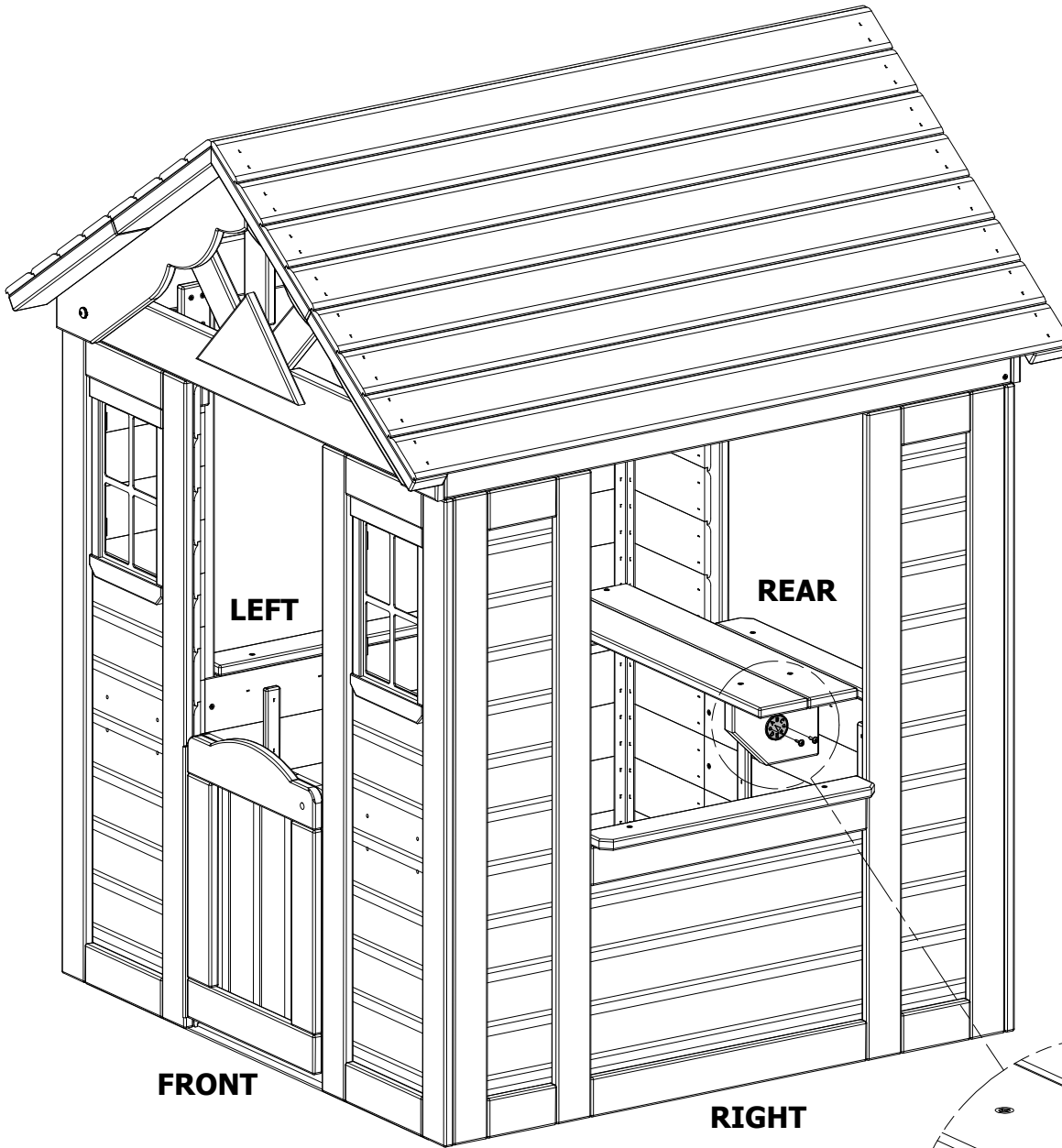
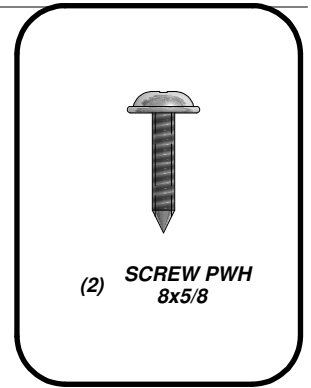

SCREW PWH 8x5/8
(2 PLCS)

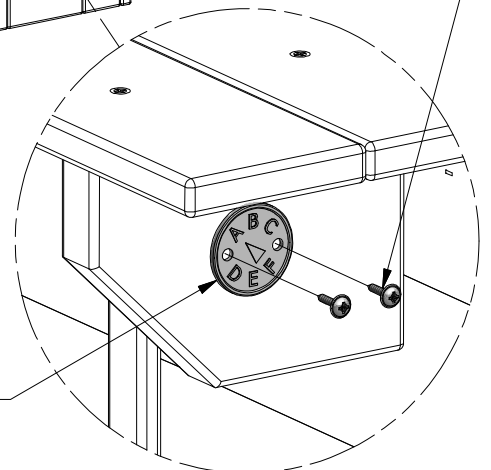

"A" REVISION TAG

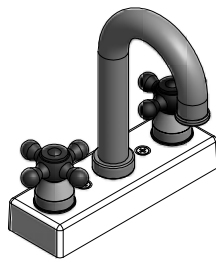

(1) FAUCET KIT - A6P00024

STEP 20:

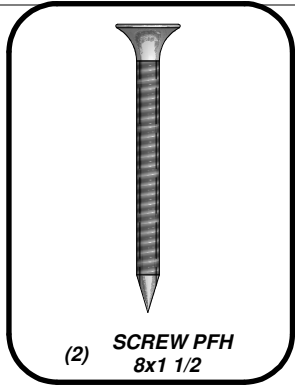
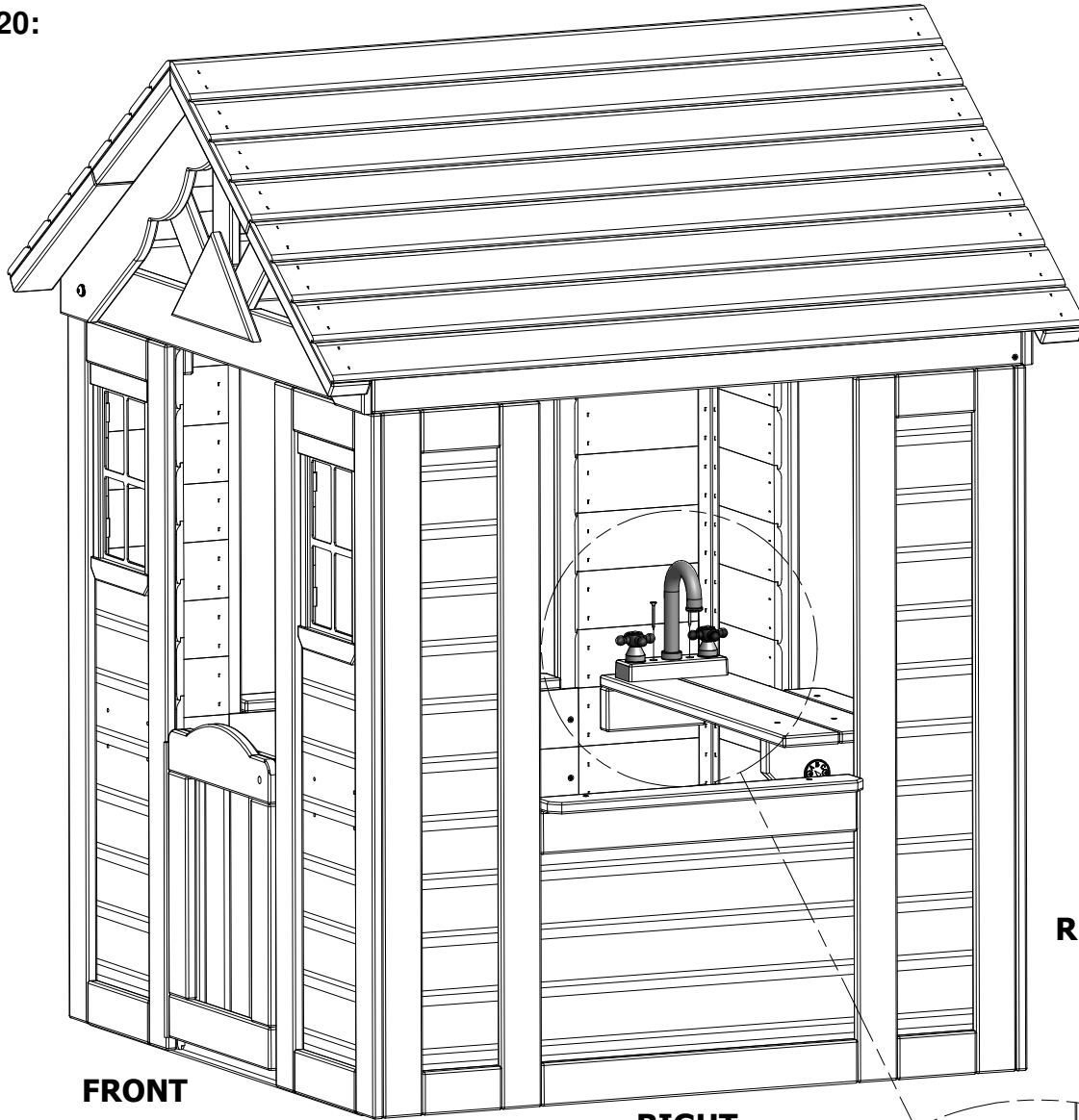

(2) SCREW PFH
8x1 1/2

FRONT

RIGHT

REAR

SCREW PFH 8x1 1/2
(2 PLCS)

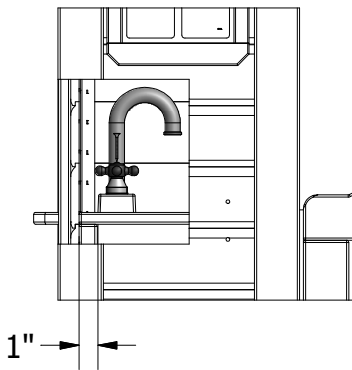

1"

FAUCET KIT

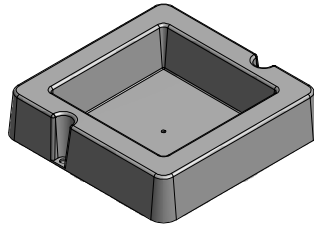

(1) SURFACE MOUNT BASIN - A6P00032

STEP 21:

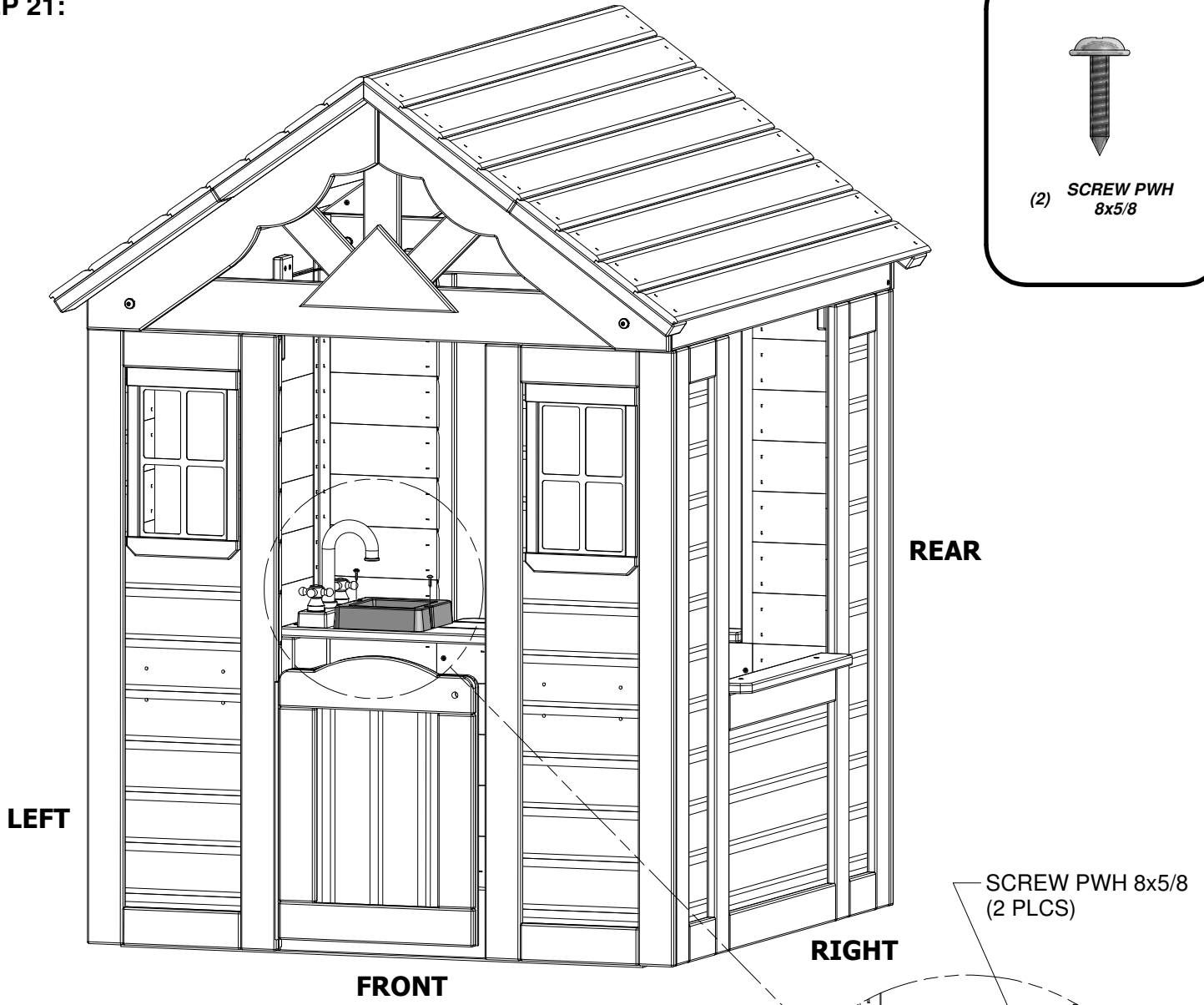
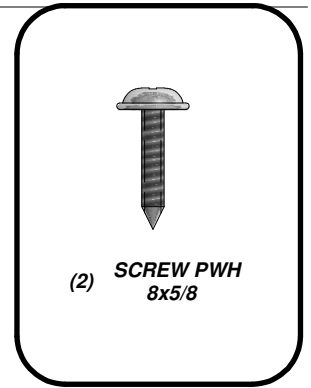

SCREW PWH 8x5/8
(2 PLCS)

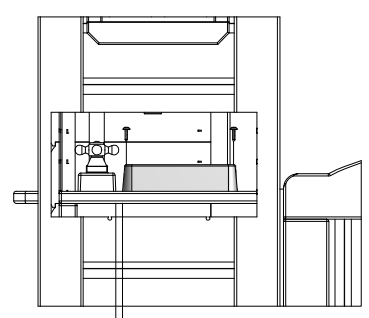

3/8" →

SURFACE MOUNT BASIN

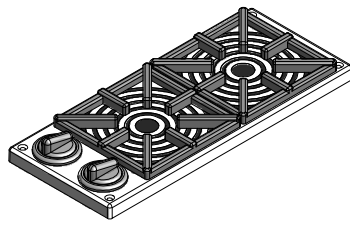

(1) STOVE KIT - A6P00025

STEP 22:

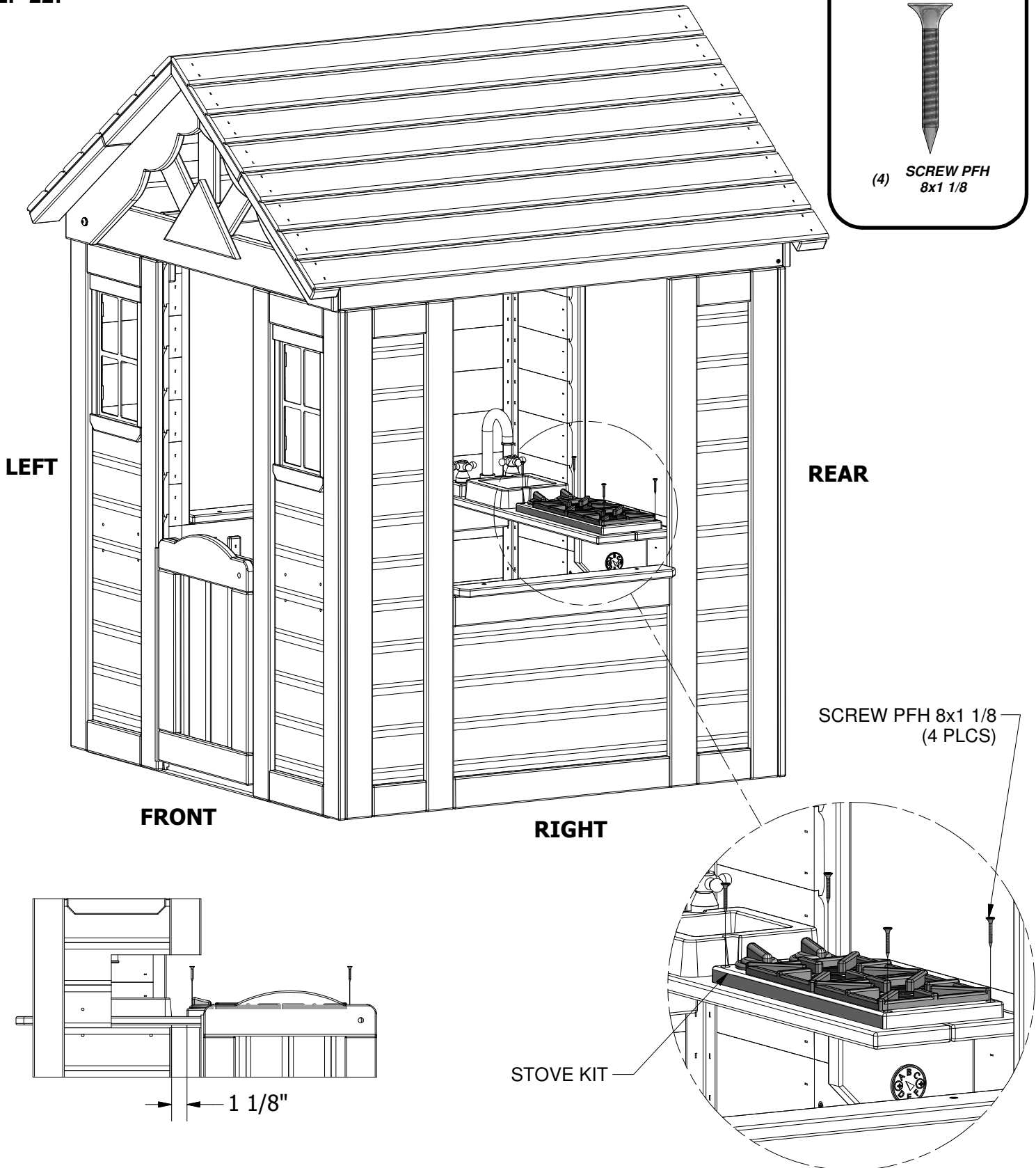

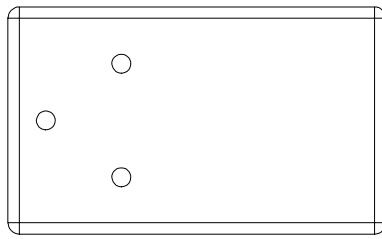

(1) **N3 - DOOR STOP - W4L04761**
5/8"x2 3/8"x3 7/8" (16x60x100)

STEP 23:

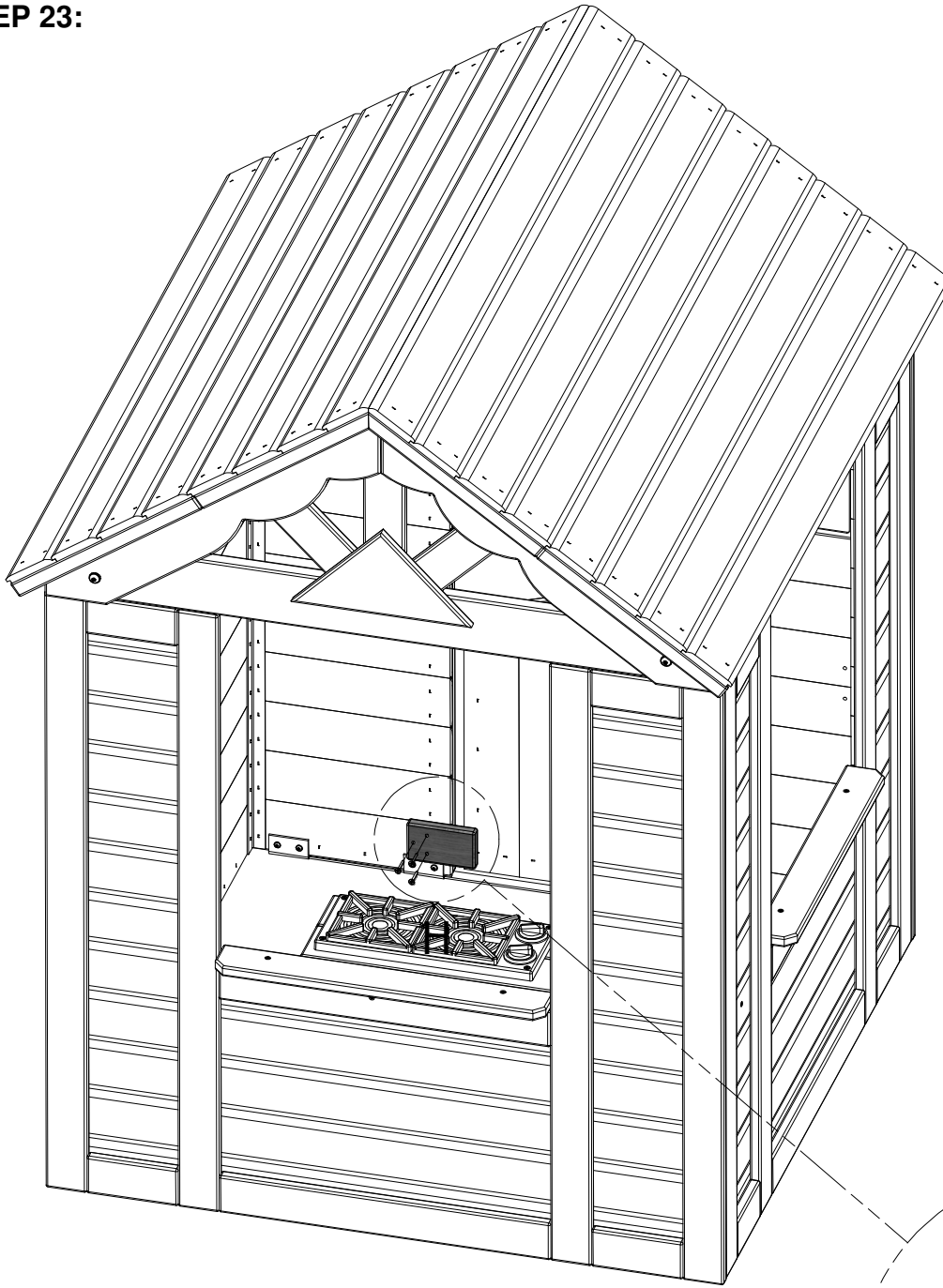
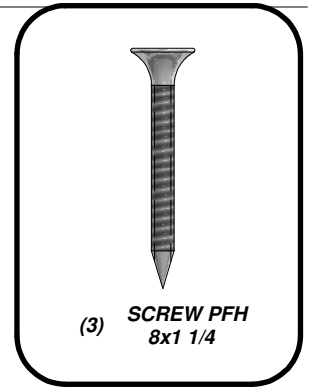

SCREW PFH 8x1 1/4
(3 PLCS)

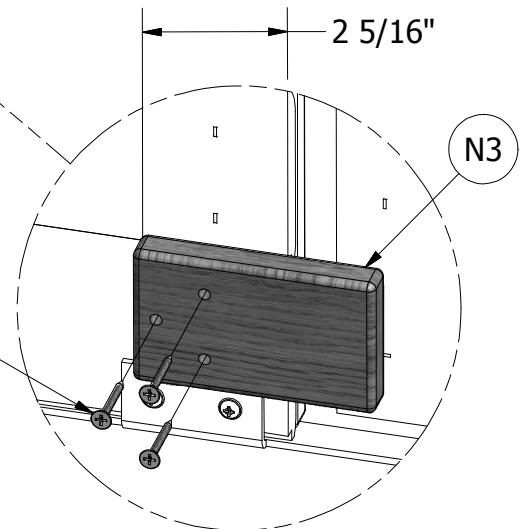

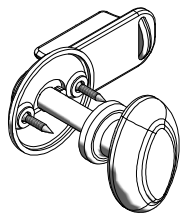

(1) KNOB KIT - A6P00020

STEP 24:

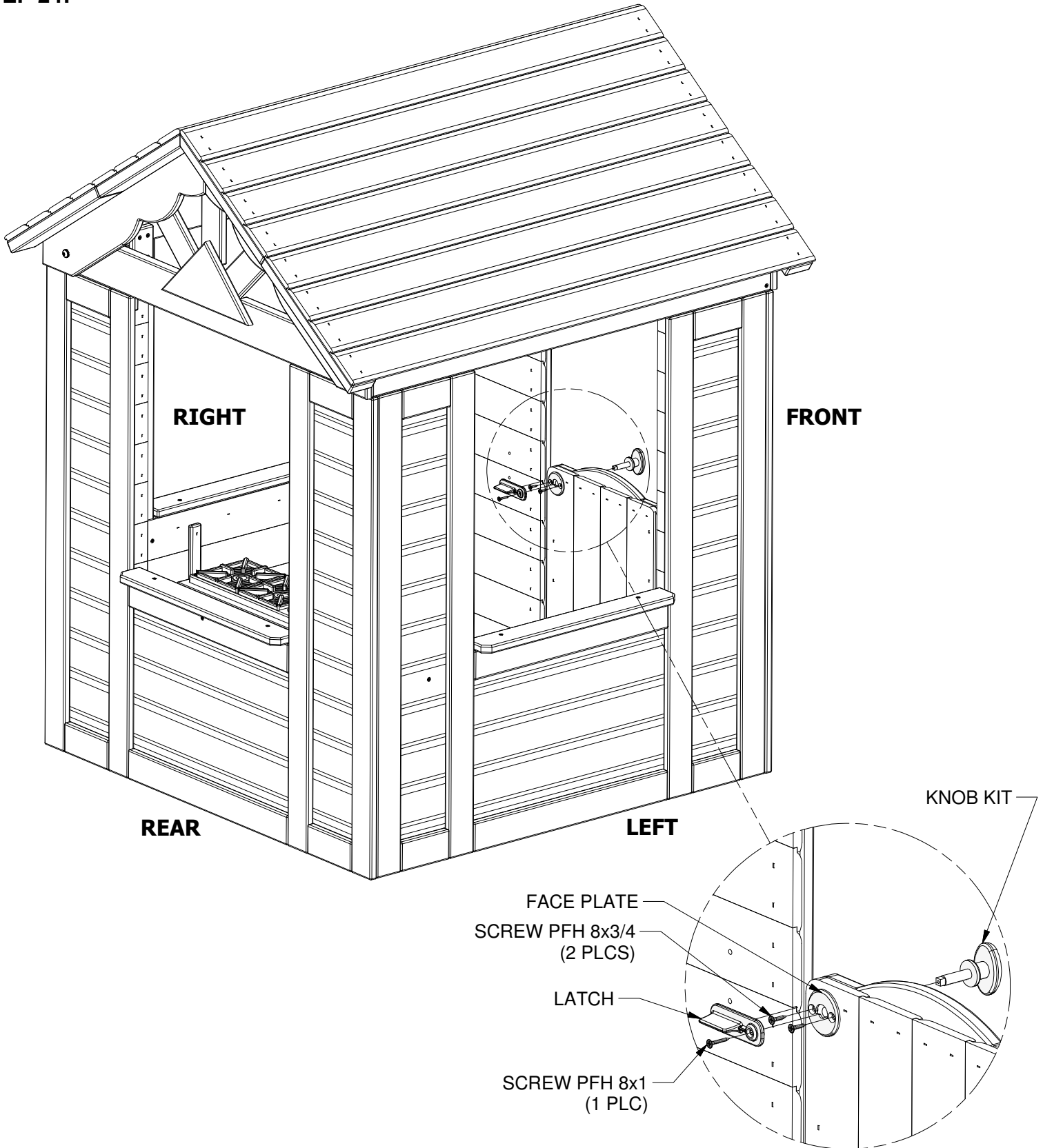



(1) PHONE KIT - A100132

STEP 25:

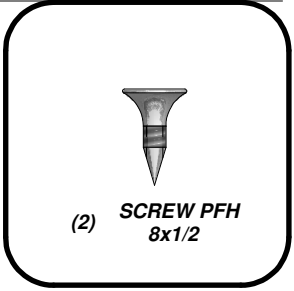

(2) SCREW PFH
8x1/2

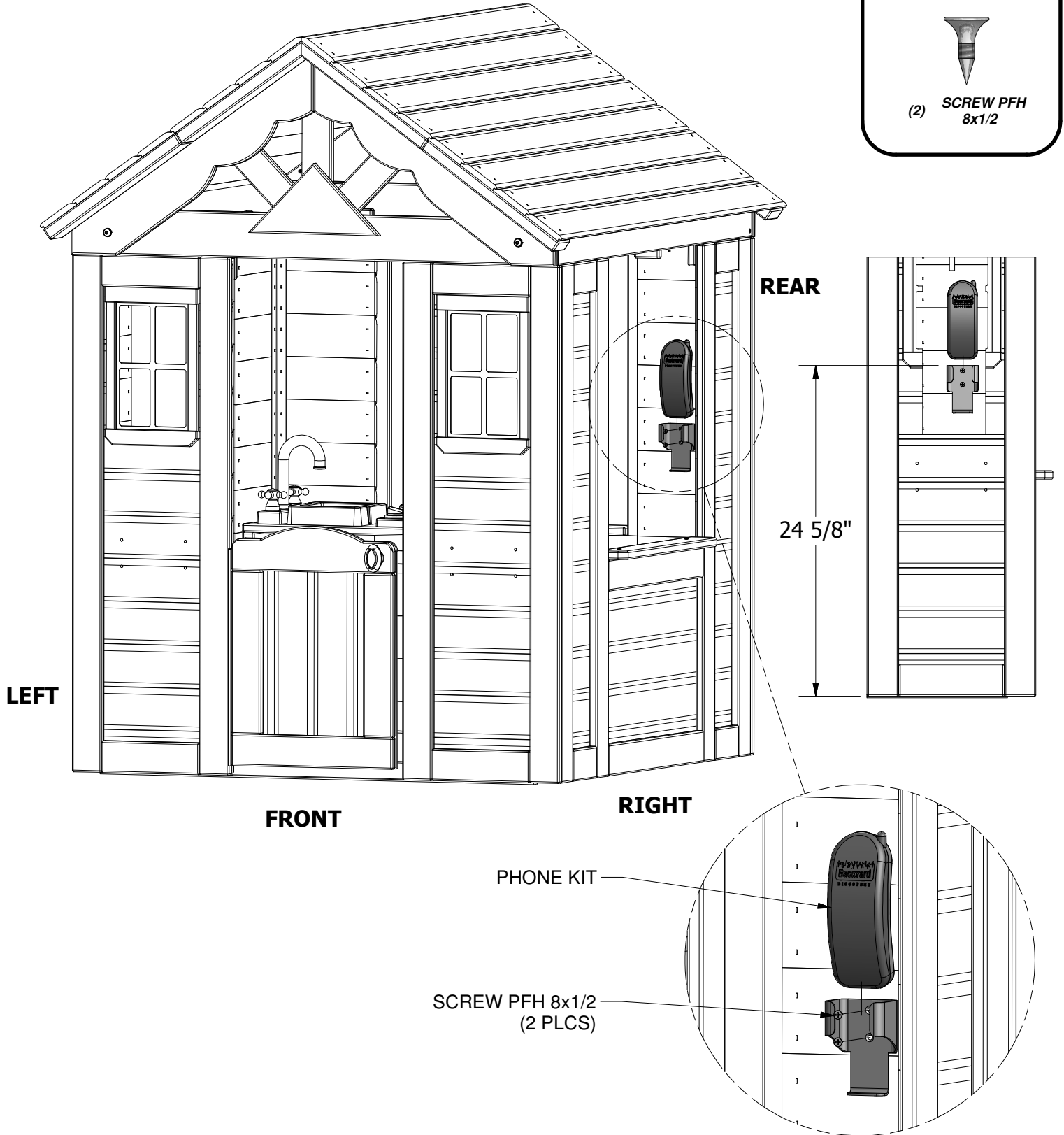

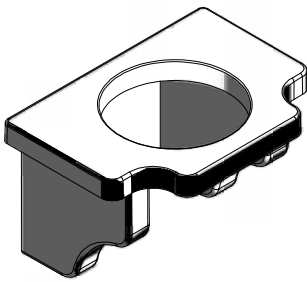

(2) FLOWER POT HOLDER - A6P00023

STEP 26:

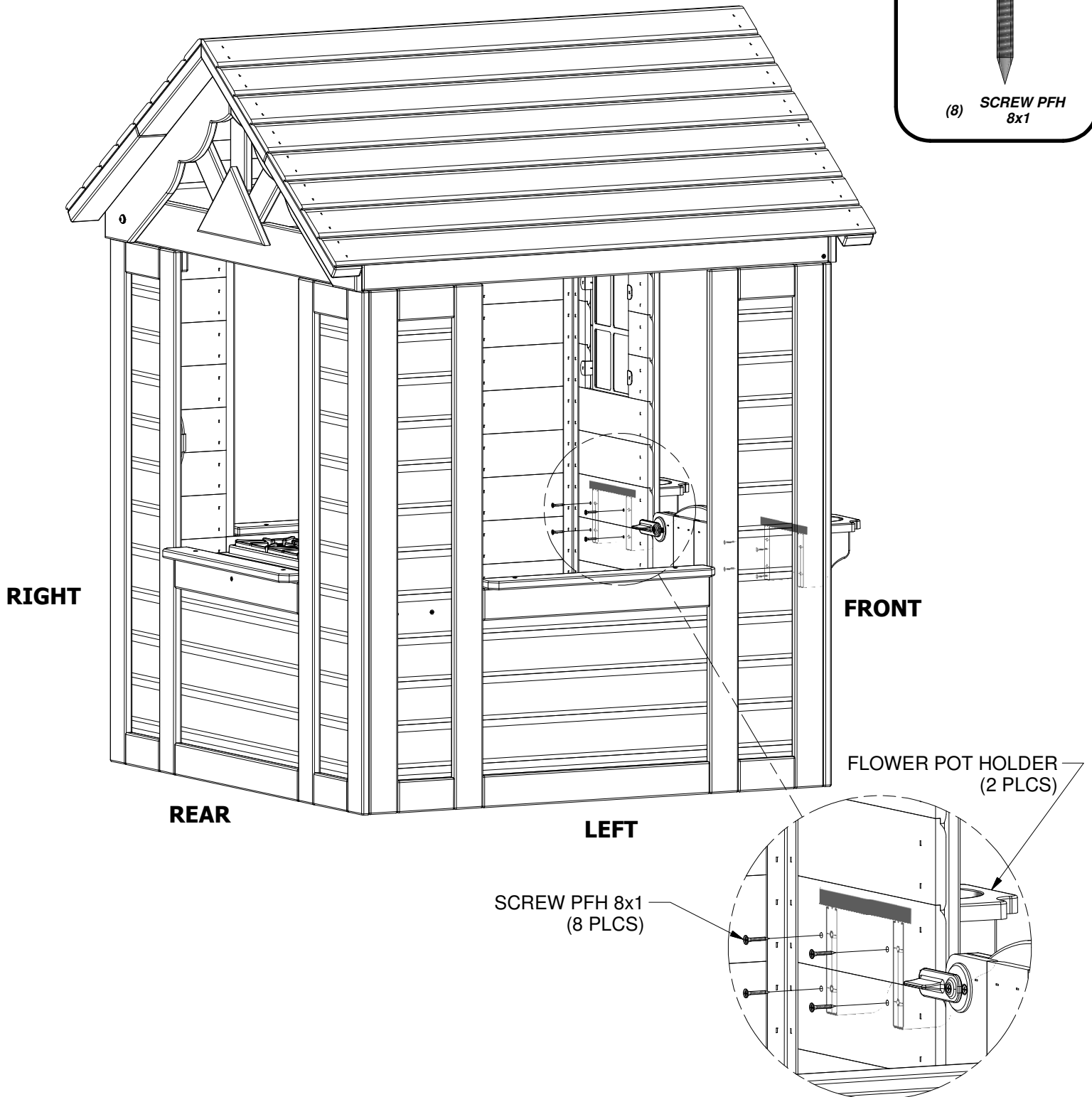
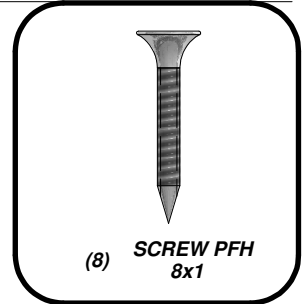



(1) **BYD ID TAG (MEDIUM) AGES 2 TO 10 - A4M00528**

STEP 27:

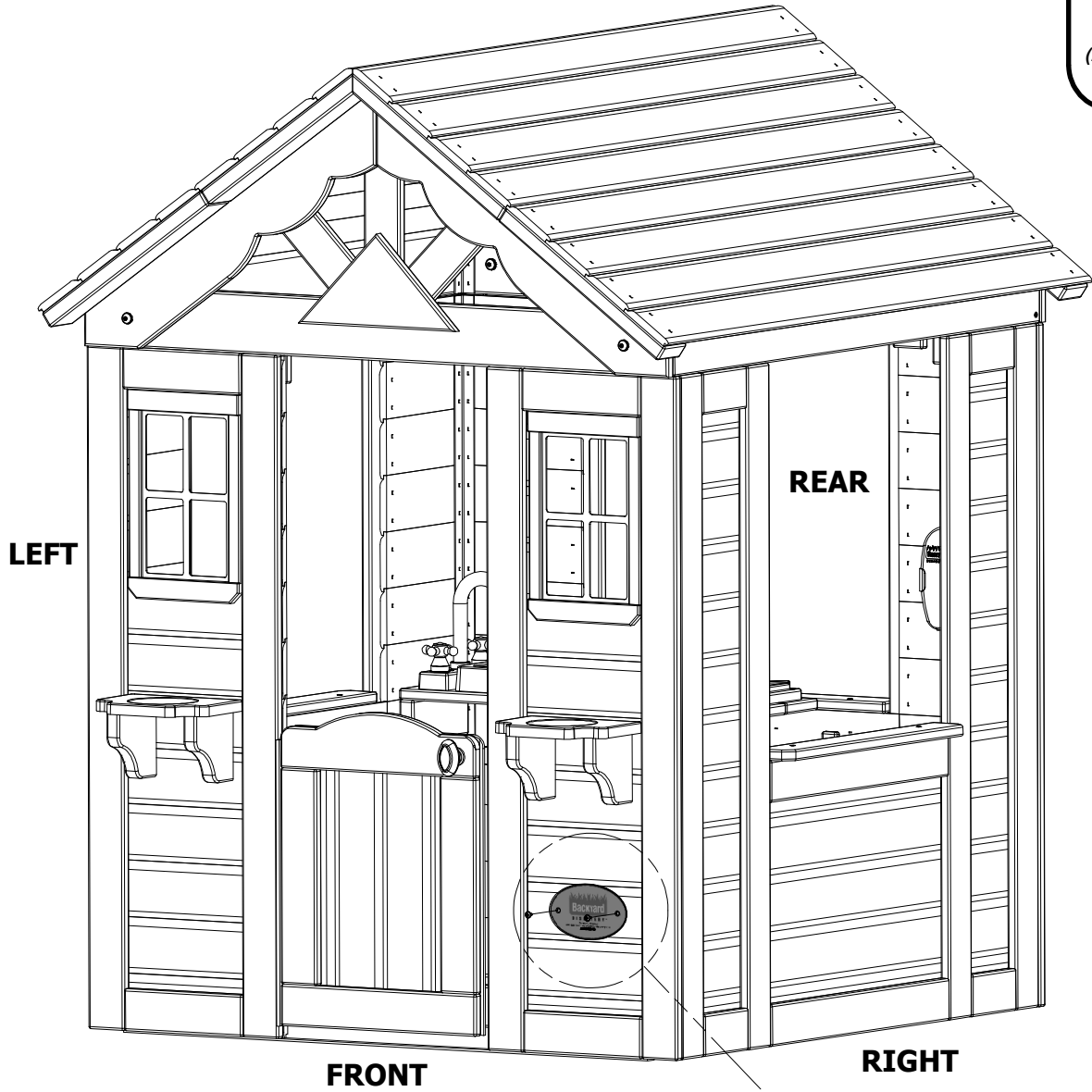

SCREW PWH 8x7/16
(2 PLCS)

