



### WARNING

**Adult Assembly Required.**  
**Not suitable for children under two years,**  
**due to sharp points and small parts.**



**INSTALLATION  
SERVICES  
AVAILABLE!\***

*Need a helping hand?*

Let our team of professionals handle the installation for you!

**GOCONFIGURE**  
888-888-5424

\*Installation services are only available to U.S. customers.

average 2 person assembly time



assembly time may vary based on skill level

*Before you begin* >>>

**FOR QUICK &  
EASY ASSEMBLY**  
FIND 3D INSTRUCTIONS  
FOR THIS PRODUCT IN

**BILT.®**

DOWNLOAD THE FREE APP



For the most up to date assembly manual,  
to register your set, or to order replacement parts please visit

**[www.backyarddiscovery.com](http://www.backyarddiscovery.com)**

**SAVE THIS ASSEMBLY MANUAL FOR FUTURE REFERENCE IN THE  
EVENT THAT YOU NEED TO ORDER REPLACEMENT PARTS.**



**GOCONFIGURE**  
*Putting it all together for you*

# INSTALLATION SERVICES AVAILABLE!\*

*Need a helping hand?*

Let our team of professionals handle the installation for you!

**GOCONFIGURE**  
**888-888-5424**

*\*Installation services are only available  
to U.S. customers.*

With Go Configure, we bring you 18 years of experience right to your doorstep. We service a wide array of indoor and outdoor recreation products that most consumers don't have the time or ability to deliver & install themselves.

**We do the heavy lifting, so you don't have to!**

- 18+ Years of Experience Servicing Big Box Retailers and Direct Consumers
- Highly Skilled, Specialized, Courteous, Professional Service Technicians
- Over 140,000 Installations Annually
- White Glove Service

- Satisfaction Guarantee
- Flexible Appointments, including weekends
- Coverage across the nation

**Visit [www.goconfigure.com](http://www.goconfigure.com) for more info!**

*\*Installation services are only available to U.S. customers.*



The store where you made your purchase does not stock parts for this item. If you have assembly questions or you are missing or have damaged parts, please call

**1-800-856-4445**

you can also visit [www.backyarddiscovery.com](http://www.backyarddiscovery.com)  
or e-mail [customerservice@backyarddiscovery.com](mailto:customerservice@backyarddiscovery.com)

**Please have the following information ready when you make your call:**

- Model Number of the product located on the front of the assembly manual
  - The item description and number from the parts list from the manual that was included in your box
- 
- Read entire assembly manual, paying special attention to the important tips and safety information.
  - To ensure there are no missing pieces do a complete inventory by first separating and identifying all parts.
  - Make sure to check packing material for small parts that may have fallen out during shipment.
  - Structures are not intended for public use. The Company does not warranty any of its residential structures subjected to commercial use.
  - This manual contains helpful information concerning assembly preparation, installation procedure and required maintenance.
  - Always keep safety in mind as your structure is being built.
  - Keep these instructions for future reference.



Please read entire booklet completely before beginning the assembly process

Please retain these instructions and your receipt for future reference. Keep them in a safe place where you can refer to them as needed. In order to provide you with the most efficient service, it is required that you provide us with the part numbers when ordering parts.

### For Your Records:

Please take time and fill out the information below. This information will be needed for warranty issues.

Where Purchased: \_\_\_\_\_  
 Date of Purchase: \_\_\_\_\_  
 Installation Date: \_\_\_\_\_  
 Installed by: \_\_\_\_\_  
 Tracking Number: \_\_\_\_\_

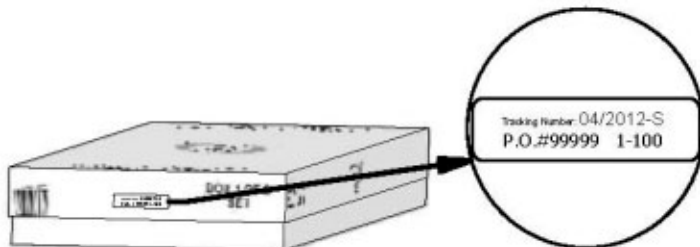

### Tracking Number Reference Label

Tracking ID number on the carton and on the bottom of the vertical ID plate are included for tracking purposes associated with warranty claims.

This Limited Warranty by Backyard Discovery applies to products manufactured under the Backyard Discovery brand or its other brands including but not limited to Backyard Botanical, Adventure Playsets, and Leisure Time Products.

Backyard Discovery warrants that this product is free from defect in materials and workmanship for a period of one (1) year from the original date of purchase. This one (1) year warranty covers all parts including wood, hardware, and accessories. All wood carries a five (5) year pro-rated warranty against rot and decay. Refer to the schedule below for charges associated with replacement of parts under this Limited Warranty. In addition, Backyard Discovery will replace any parts within the first 30 days from date of purchase found to be missing from or damaged in the original packaging.

This warranty applies to the original owner and registrant and is non-transferable. Regular maintenance is required to assure maximum life and performance of this product. Failure by the owner to maintain the product according to the maintenance requirements may void this warranty. Maintenance guidelines are provided in the Owner's Manual.

This Limited Warranty does not cover:

- Installation
- Labor for any inspection
- Labor for replacement of any defective item(s)
- Incidental or consequential damages
- Cosmetic defects which do not affect performance or integrity of a part or the entire product
- Vandalism, improper use, failure due to loading or use beyond the capacities stated in the applicable Assembly Manual.
- Acts of nature including but not limited to wind, storms, hail, floods, excessive water exposure
- Improper installation including but not limited to installation on uneven, unlevel, or soft ground
- Minor twisting, warping, checking, or any other natural occurring properties of wood that do not affect performance or integrity

Backyard Discovery products have been designed for safety and quality. Any modifications made to the original product could damage the structural integrity of the unit leading to failure and possible injury. Modification voids any and all warranties and Backyard Discovery assumes no liability for any modified products or consequences resulting from failure of a modified product.

This product is warranted for RESIDENTIAL USE ONLY. Under no circumstance should a Backyard Discovery product be used in public settings. Such use may lead to product failure and potential injury. Any and all public use will void this warranty. Backyard Discovery disclaims all other representations and warranties of any kind, express or implied.

### Pro Rated Part Replacement Schedule

<u>Product Age</u>	<u>Customer Pays</u>
<b>All Parts</b>	
0-30 days from date of purchase	\$0 and free shipping
31 days to 1 year	\$0 + S&H
<b>Wood Rot and Decay Only</b>	
1 year	\$0 and free shipping
2 year	20% + S&H
3 year	40% + S&H
4 year	60% + S&H
5 year	80% + S&H
Over 5 years	100% + S&H



### NOTE:

#### Your Children's Safety Is Our #1 Concern!

Observe the following statements and warnings to reduce the likelihood of serious or fatal injury. Please review these safety rules regularly with your children.



#### WARNING: BURN HAZARD

- Pay special attention to plastic and metal surfaces as they may be hot enough to cause burns.
- Always check the temperature of the product before letting your children play on it.
- Remember that the product may cause burns if left in direct sunlight.
- Always be aware of the sun and weather conditions, and do not assume that the equipment is safe because the air temperature is not very high.

- Equipment is recommended for use by children 2 to 10 years of age.
- On-site adult supervision is required.
- Instruct children not to climb when the equipment is wet.
- Instruct children to never crawl on top of a play house roof.
- The parents should have the children dress appropriately with well-fitting shoes. Loose clothing such as scarves and ponchos should not be worn. Always take off, tie up or tuck in cords and drawstrings on children's clothing. These things can get caught on playground equipment and strangle a child.
- Instruct children not to attach items to the equipment that are not specifically designed for use with that equipment (such as ropes, clothesline, pet leashes, etc.).
- Instruct children to remove their bike or other sports helmet before playing on the playground equipment.
- Instruct children to **always** go down slides feet first. Never slide head first.
- Instruct children to **look** before they slide to make sure no one is at the bottom.
- Do **not** allow children to run up a slide, as this increases their chances of falling.



### Positioning Your Playhouse

- The playhouse is designed to be installed on a level surface by an Adult with an Adult helper. Place in a flat area of your yard to minimize ground preparation.
- Choose a level location for the equipment. This can reduce the likelihood of the playhouse tipping over and loose-fill surfacing material washing away during heavy rains.
- Place the equipment not less than 6 ft (1.8 m) from any structure or obstruction such as a fence, garage, house, overhanging branches, laundry lines, or electrical wires.
- It is a good idea to place your playhouse in an area that is convenient for adults to watch children at play.
- Create a site free of obstacles that could cause injuries – such as low overhanging tree branches, overhead wires, tree stumps and/or roots, large rocks, bricks and concrete. We have additional suggestions in the Suggested Playground Surfacing Section.
- Do not build your playhouse on top of surfacing material.

### Suggested Playground Surfacing

- Do not install home playground equipment over concrete, asphalt, packed earth, grass, carpet, or any other hard surface. A fall onto a hard surface can result in serious injury to the equipment user.
- Do not install loose fill surfacing over hard surfaces such as concrete or asphalt.
- Shredded bark mulch, wood chips, fine sand and fine gravel, are added as shock absorbing materials after assembly. If used properly these materials can absorb some of the impact of a child's fall.
- All surface material should extend a minimum of 6 feet in all directions around the play area.
- Do not apply playground surfacing until after the unit is completely constructed. Play house should not be built on top of surfacing.
- Use containment, such as digging out around the perimeter and/or lining the perimeter with landscape edging.
- Installations of rubber tiles or poured-in-place surfaces (other than loose-fill materials) generally require a professional and are not "do-it-yourself" projects.
- Shall use Playground Surfacing Materials (other than loose-fill material) which comply with the safety standard ASTM F1292 Standard Specification of Impact Attenuation of Surfacing Materials within the Use Zone of Playground Equipment.

The following chart explains the fall height in feet from which a life threatening head injury would not be expected

### Critical Heights in feet (m) of Tested Materials

Material	Uncompressed Depth			Compressed Depth to 9" (228mm)
	6" (152mm)	9" (228mm)	12" (304mm)	
Wood Chips	7' (2.13m)	10-12' (3.0-3.6m)	11' (3.35m)	10' (3.05m)
Double-Shredded Bark Mulch	6' (1.83m)	10-12' (3.0-3.6m)	11' (3.35m)	7' (2.13m)
Engineered Wood Fibers	6' (1.83m)	7' (2.13m)	>12' (3.66m)	6' (1.83m)
Fine Sand	5' (1.52m)	5' (1.52m)	9' (2.74m)	5' (1.52m)
Coarse Sand	5' (1.52m)	5' (1.52m)	6' (1.83m)	4' (1.22m)
Fine Gravel	5' (1.52m)	7' (2.13m)	10' (3.05m)	6' (1.83m)
Medium Gravel	5' (1.52m)	5' (1.52m)	6' (1.83m)	5' (1.52m)
Shredded Tires*	10-12' (3.0-3.6m)	N/A	N/A	N/A

\*This data is from tests conducted by independent testing laboratories on a 6-inch depth of uncompressed shredded tire samples produced by four manufacturers. The tests reported critical heights, which varied from 10 feet to greater than 12 feet. It is recommended that persons seeking to install shredded tires as a protective surface request test data from the supplier showing the critical height of the material when it was tested in accordance with ASTM F1292.



### APPENDIX A

**The following information is from the United States Consumer Product Safety Commission's Information Sheet for playground surfacing material; also see the following website for additional information: [www.cpsc.gov](http://www.cpsc.gov)**

X3. SECTION 4 OF THE CONSUMER PRODUCT SAFETY COMMISSION'S OUTDOOR HOME PLAYGROUND SAFETY HANDBOOK<sup>9</sup>

X3.1 Select Protective Surfacing—One of the most important things you can do to reduce the likelihood of serious head injuries is to install shock-absorbing protective surfacing under and around your play equipment. The protective surfacing should be applied to a depth that is suitable for the equipment height in accordance with ASTM Specification F 1292. There are different types of surfacing to choose from; whichever product you select, follow these guidelines:

X3.1.1 Loose-Fill Materials:

X3.1.1.1 Maintain a minimum depth of 9 inches of loose-fill materials such as wood mulch/chips, engineered wood fiber (EWF), or shredded/recycled rubber mulch for equipment up to 8 feet high; and 9 inches of sand or pea gravel for equipment up to 5 feet high. NOTE: An initial fill level of 12 inches will compress to about a 9-inch depth of surfacing overtime. The surfacing will also compact, displace, and settle, and should be periodically refilled to maintain at least a 9-inch depth.

X3.1.2 Use a minimum of 6 inches of protective surfacing for play equipment less than 4 feet in height. If maintained properly, this should be adequate. (At depths less than 6 inches, the protective material is too easily displaced or compacted.)

NOTE: Do not install home playground equipment over concrete, asphalt, or any other hard surface. A fall onto a hard surface can result in serious injury to the equipment user. Grass and dirt are not considered protective surfacing because wear and environmental factors can reduce their shock absorbing effectiveness. Carpeting and thin mats are generally not adequate protective surfacing. Ground level equipment such as a sandbox, activity wall, playhouse or other equipment that has no elevated play surface – does not need any protective surfacing.

X3.1.3 Use containment, such as digging out around the perimeter and/or lining the perimeter with landscape edging. Don't forget to account for water drainage.

X3.1.3.1 Check and maintain the depth of the loose-fill surfacing material. To maintain the right amount of loose-fill materials, mark the correct level on play equipment support posts. That way you can easily see when to replenish and/or redistribute the surfacing.

X3.1.3.2 Do not install loose-fill surfacing over hard surfaces such as concrete or asphalt.

X3.1.4 Poured-In-Place Surfaces or Pre-Manufactured Rubber Tiles — You may be interested in using surfacing other than loose-fill materials – like rubber tiles or poured-in-place surfaces.

X3.1.4.1 Installations of these surfaces generally require a professional and are not “do-it-yourself” projects.

X3.1.4.2 Review surface specification before purchasing this type of surfacing. Ask the installer/manufacturer for a report showing that the product has been tested to the following safety standard: ASTM F 1292 Standard Specification for Impact Attenuation of Surfacing Materials within the Use Zone of Playground Equipment. This report should show the specific height for which the surface is intended to protect against serious head injury. This height should be equal to or greater than the fall height – vertical distance between a designated play surface (elevated surface for standing, sitting, or climbing) and the protective surfacing below – of your play equipment

X3.1.4.3 Check the protective surfacing frequently for wear.

X3.1.5 Placement — Proper placement and maintenance of protective surfacing is essential. Be sure to:

X3.1.5.1 Extend surfacing at least 6 feet from the equipment in all directions.

X3.1.5.2 For to-fro swings, extend protective surfacing in front of and behind the swing to a distance equal to twice the height of the top bar from which the swing is suspended.

<sup>9</sup>This information has been extracted from the CPSC publications “Playground Surfacing — Technical Information Guide” and “Handbook for Public Playground Safety.” Copies of these reports can be obtained by sending a postcard to the: Office of Public Affairs, U.S. Consumer Product Safety Commission, Washington, D.C., 20207 or call the toll-free hotline: 1-800-638-2772.

The American Society for Testing and Materials takes no position respecting the validity of any parent right asserted in connection with any item mentioned in this standard. Users of this standard are expressly advised that determination of the validity of any such parent rights, and the risk of infringement of such rights, are entirely their own responsibility.

The standard is subject to revision at any time by the responsible technical committee and must be reviewed every five years and if not revised, either approved or withdrawn. Your comments are invited either for revision of this standard or for additional standards and should be addressed to ASTM Headquarters. Your comments will receive careful consideration at a meeting of the responsible technical committee, which you may attend. If you feel that your comments have not received a fair hearing you should make your views known to the ASTM Committee on Standards. 100 Barr Harbor Drive, West Conshohocken, PA 19428.



**IT IS IMPORTANT TO CHECK AND TIGHTEN ALL HARDWARE AT THE BEGINNING AND DURING THE SEASON AS THEY MAY LOOSEN DUE TO WOOD EXPANSION AND CONTRACTION.**

### **At the beginning of each play season**

- Tighten all hardware.
- Lubricate all metallic moving parts per manufacturer's instructions.
- Check all protective coverings on bolts, pipes, edges, and corners. Replace if they are loose, cracked, or missing.
- Check all moving parts including swing seats, ropes, cables, and chains for wear, rust, or other deterioration. Replace as needed.
- Check metal parts for rust. If found, sand and repaint using a non lead-based paint meeting the requirements of 16 CFR 1303.
- Check all wood members for deterioration and splinters. Sand down splinters and replace deteriorating wood members.
- Reinstall any plastic parts, such as swing seats or any other items that were removed for the cold season.
- Rake and check depth of loose fill protective surfacing materials to prevent compaction and to maintain appropriate depth. Replace as necessary.

### **Twice a month during play season**

- Tighten all hardware.
- Check all protective coverings on bolts, pipes, edges, & corners. Replace if they are loose, cracked, or missing.
- Rake and check depth of loose fill protective surfacing materials to prevent compaction and to maintain appropriate depth. Replace as necessary.

### **Once a month during play season.**

- Lubricate all metallic moving parts per manufacturer's instructions.
- Check all moving parts including swing seats, ropes, cables, and chains for wear, rust, or other deterioration. Replace as needed.

### **At the end of each play season or when the temperature drops below 32° F**

- Remove plastic swing seats and other items as specified by the manufacturer and take indoors or do not use.
- Rake and check depth of loose fill protective surfacing materials to prevent compaction and to maintain appropriate depth. Replace as necessary.

### **Additional Maintenance**

- Check the swing beam and hardware every two weeks due to wood expansion and contraction. It is particularly important that this procedure be followed at the beginning of each season.
- Inspect wood parts monthly. The grain of the wood sometimes will lift in the dry season causing splinters to appear. Light sand may be necessary to maintain a safe playing environment. Treat your playset with stain regularly, to help prevent severe checking/ splitting and other weather damage.
- A waterborne transparent stain has been applied to your playset. This is done for color only. Once or twice a year, depending on your climate conditions, you must apply some type of protection (sealant) to the wood of your unit. Prior to the application of sealant, lightly sand any "rough" spots on your playset. Please note this is a requirement of your warranty.
- Assembling and maintaining the playset on a level location is very important. As your children play, your playset will slowly dig its way into the soil, and it is very important that it settles evenly. Make sure the playset is level and true one each year or at the beginning of each play season.

### **Disposal Instructions**

When the Playcenter use is no longer desired, it should be disassembled and disposed of in such a way that no unreasonable hazards will exist at the time the unit is discarded.

### **Third Party Assembly**

Customer may, in their sole discretion, elect to use a third party person or service to assemble this product. Backyard Discovery assumes no responsibility or liability for any charge incurred by the Customer for any assembly services'. Please see our warranty for more information about damaged and missing part replacement coverage. Backyard Discovery will not reimburse Customer for the price of parts purchased.

**OWNERS SHALL BE RESPONSIBLE FOR MAINTAINING THE LEGIBILITY OF THE WARNING LABELS**





***Your Backyard Discovery structure is designed and constructed of quality materials. As with all outdoor products it will weather and wear. To maximize the enjoyment, safety and life of your structure it is important that you properly maintain it.***

---

### About Our Wood

Backyard Discovery uses 100% Cedar (C. Lanceolata) wood. Although we take great care in selecting the best quality lumber available, wood is still a product of nature and susceptible to weathering which can change the appearance of your set.

#### **What causes weathering? Does it affect the strength of my product?**

One of the main reasons for weathering is the effects of water (moisture); the moisture content of the wood at the surface is different than the interior of the wood. As the climate changes, moisture moves in or out of the wood, causing tension which can result in checking and or warping. You can expect the following due to weathering. These changes will not affect the strength of the product:

**1. Checking** is surface cracks in the wood along the grain. A post (4" x 4") will experience more checking than a board (1" x 4") because the surface and interior moisture content will vary more widely than in thinner wood.

**2. Warping** results from any distortion (twisting, cupping) from the original plane of the board and often happens from rapid wetting and drying of the wood.

**3. Fading** happens as a natural change in the wood color as it is exposed to sun-light and will turn grey over time.

#### **How can I reduce the amount of weathering to wood product?**

**1.** Your wood product is coated with a water-based stain. Sunlight will break down the coating, so we recommend applying a water repellent or stain on a yearly basis (see your local stain and paint supplier for a recommended product). You must apply some type of protection (sealant) to the wood of your product. **Please note this is a requirement of your warranty.** Most weathering is just the normal result of nature and will not affect safety. However if you are concerned that a part has experienced a severe weathering problem please call our customer service department for further assistance.

**2.** Inspect wood parts monthly. The grain of the wood sometimes will lift in the dry season causing splinters to appear. Light sanding may be necessary to maintain a safe environment. Treating your Product with protection (sealant) after sanding will help prevent severe checking/ splitting and other weather damage.



### Protrusion Hazard

**Incorrect**

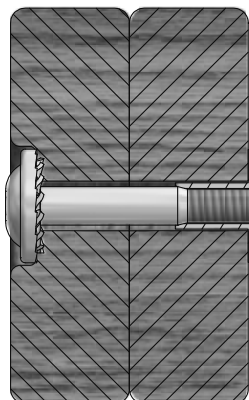

If you see exposed threads and your bolt protrudes beyond the T-Nut you may have overtightened the bolt or used incorrect hardware. If you've overtightened, remove the bolt and add washers to eliminate the protrusion.

**Correct**

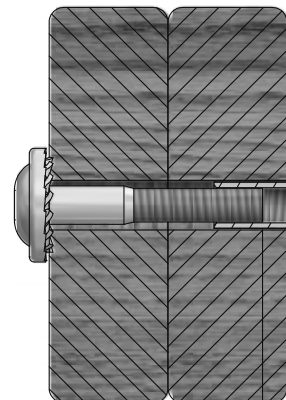

1/8"

## Proper Hardware Assembly

### Bolt and T-Nut Assembly

Tap T-nut into the provided hole. Insert your bolt through the lock washer and insert into the provided hole opposite from the T-Nut. Turn clockwise to thread into T-nut. Do not completely tighten until instructed.

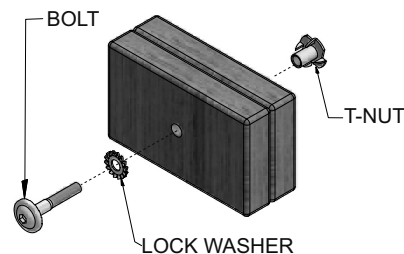

### Bolt and Barrel Nut Assembly

Insert barrel nut through the lock washer and press the pair through the provided hole. Insert your bolt through the second lock washer and insert the pair into the provided hole opposite from the barrel nut. Turn clockwise to thread into the barrel nut. Do not completely tighten until instructed.

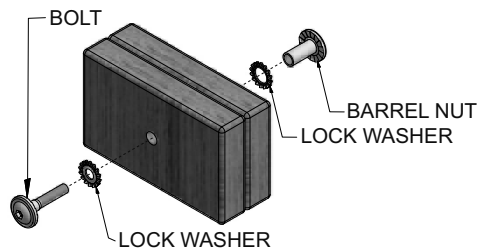

### Lag Assembly

Normally there will be a pre-drilled pilot hole on assemblies that require a Lag Screw. If there is no pilot hole, line up the two boards as they are to be attached and use the factory drilled hole as a guide to drill another pilot hole into the adjoining board. This will keep the wood from splitting. Only a lock washer is required for steps with Lag Screws.

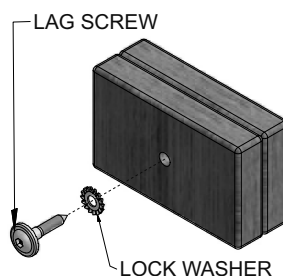



### ASSEMBLY TIP:

Keep an eye out for these boxes which will contain helpful pictures and information making the assembly process as quick and painless as possible.

## Sorting Wood

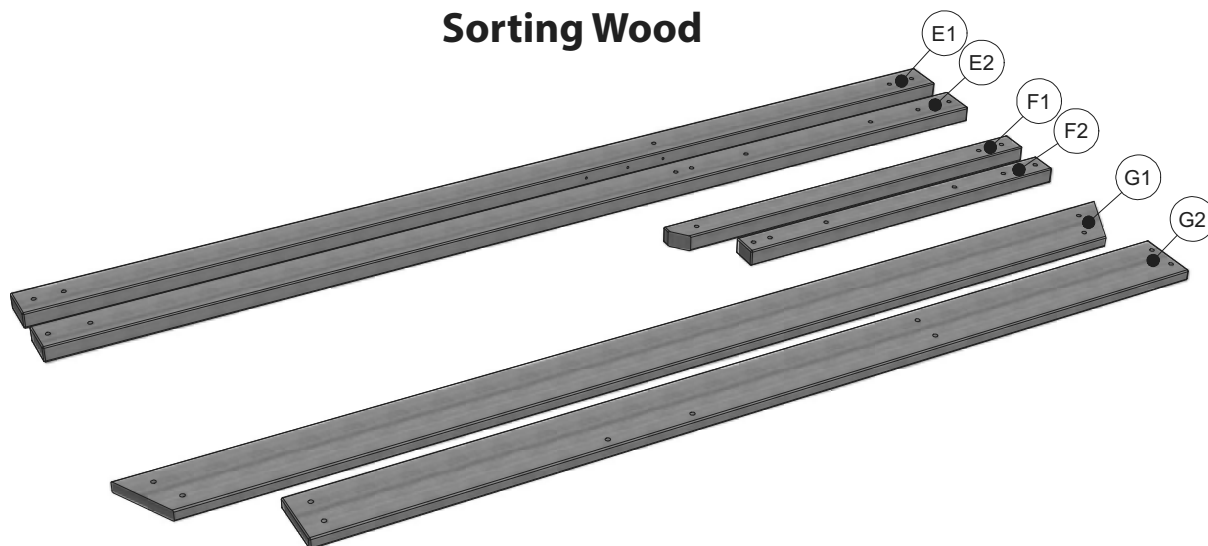

When removing the wood from the boxes we recommend arranging them by part number before you begin assembly. This will allow for faster assembly and easily identify any parts that may be missing or damaged.

## Sorting Hardware

**NUT BARREL**  
H100545



**SCREW**  
H100695

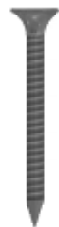

**T-NUT**  
H100699



**WASHER FLAT**  
H100706



**BOLT HEX**  
H100716

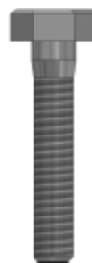

**BOLT**  
H100718



**SCREW PWH**  
H100742



To help with assembly we recommend sorting your hardware bags with the seven digit alpha-numeric number printed on the bags or by hardware type (i.e. bolts, nuts, etc.). Organizing your hardware will make assembly easier.

## Hardware Identification

Hardware bags are printed with a seven digit alpha-numeric part number. During assembly you only need to reference the last three digits of the part number as noted in each step. This will make finding the correct hardware easier.

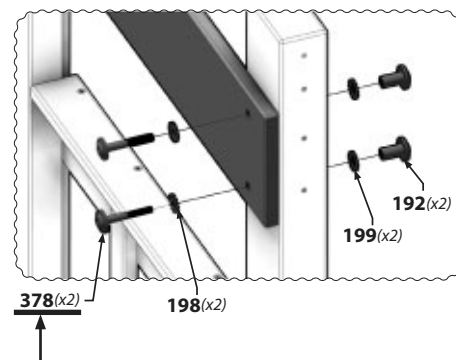
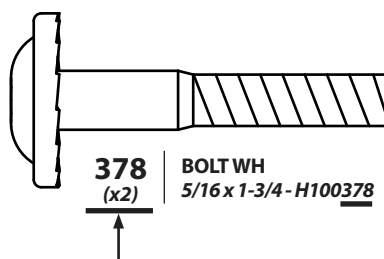

# SAFETY AND ASSEMBLY INFORMATION

SELECTING THE CORRECT LOCATION FOR YOUR PLAY PRODUCT IS IMPORTANT FOR YOUR CHILDREN'S SAFETY AND THE PRODUCT'S LONGEVITY

## Dimensions:

- The Summer Cottage has one layout option.
- Layout Ground Dimension  
5'-11 3/8" x 4'-10 5/16" x 5'-6 11/16" Tall

Safe Play Area\*  
16'-10 5/16" x 17'-11 3/8"

\*Level Ground Surface - See below

## General Information:

- Your set has been designed and engineered for children only and for residential use only.
- A maximum of 150 lbs. per child is recommended for play activities designed for individual use.
- A maximum of 120 lbs. per child is recommended for play activities designed for multiple child use.
- A maximum of 6 children is recommended for this unit.

## Safe Play Area:

- The safe play area refers to a zone extending 6' beyond the play product on all sides, including the space above the play product.
- The ground surface **must be level**. Installing your play product on sloping ground can cause it to lean or "rack". This leaning puts additional stress on all connections and joints and in time will cause those connections to loosen and fail.
- The safe play area must be free of all structures, landscaping, trees and branches, rocks, wires, and other obstacles to safe play. Children can be seriously injured running or swinging into these obstacles.
- Remove all tripping hazards from the safe play area. Tripping hazards include: roots, stumps, rocks, landscaping, sprinkler heads, railroad ties, plumbing and electrical connections.
- Play product needs to be installed on solid ground.

## SAFE PLAY AREA DIAGRAM

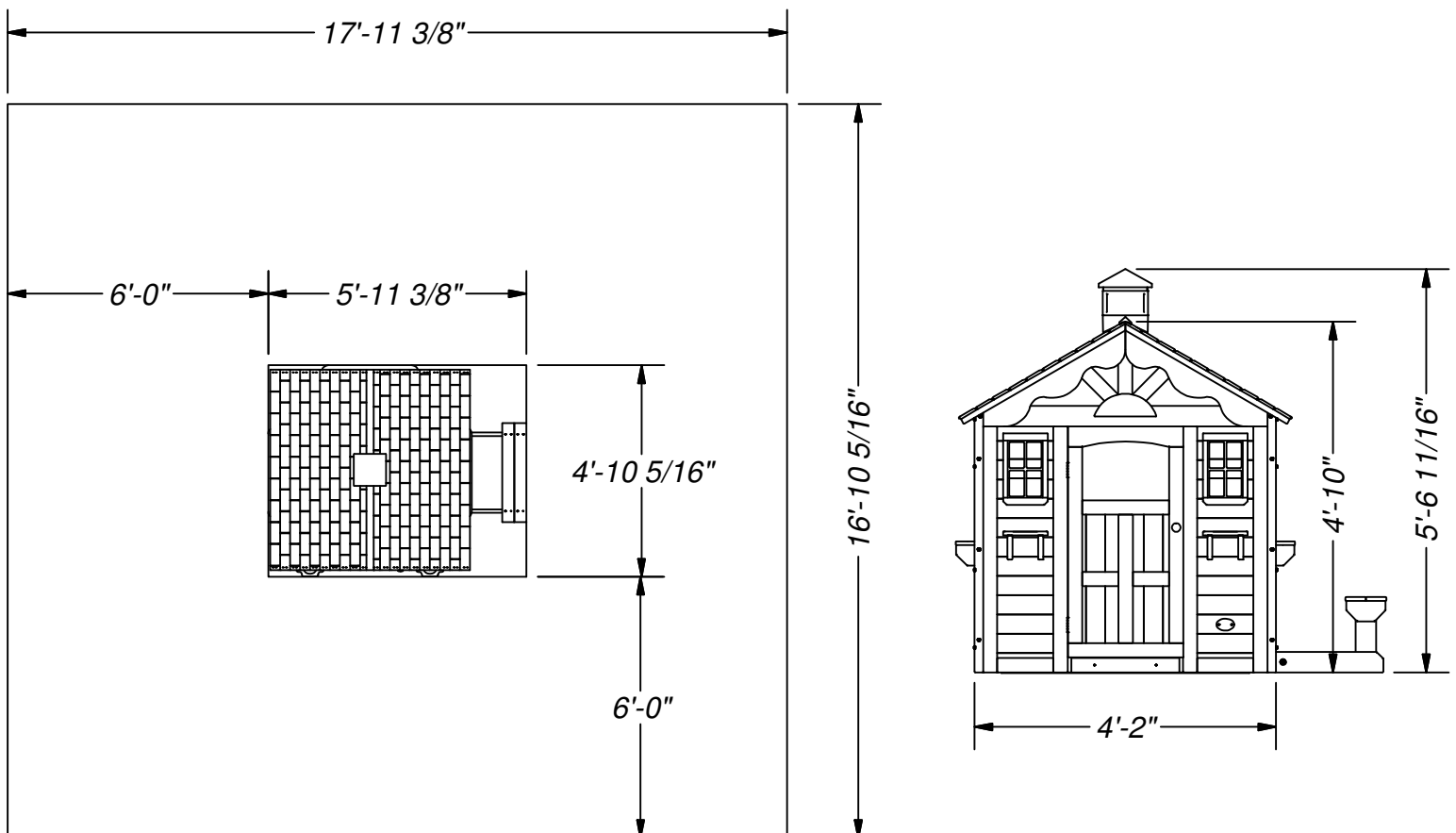

# Parts Identification

## Wood Components

(NOT TO SCALE)



- (1) **G1 - COUNTER SUPPORT - W4L05257**  
1"x5 1/4"x6 3/4" (24x134x170)



- (6) **H1 - SHELF SUPPORT - W4L05264**  
1"x3 3/8"x3 3/8" (24x86x86)

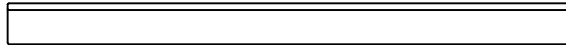

- (2) **H2 - ANGLED HEADER - W103189**  
1"x3 3/8"x47 1/8" (24x86x1198)

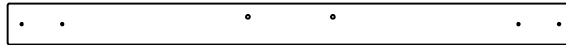

- (2) **H3 - HEADER - W103190**  
1"x3 3/8"x47 1/8" (24x86x1198)



- (2) **H4 - BENCH SEAT SUPPORT - W102470**  
1"x3 3/8"x6 1/2" (24x86x166)

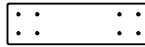

- (2) **H5 - BENCH UPRIGHT - W102471**  
1"x3 3/8"x11 3/4" (24x86x300)



- (2) **H6 - BENCH GROUND BOARD - W102472**  
1"x3 3/8"x18 1/8" (24x86x460)

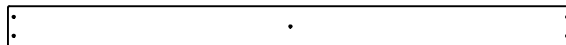

- (2) **M1 - COUNTER TOP - W4L05255**  
5/8"x3 3/8"x47 1/8" (16x86x1196)

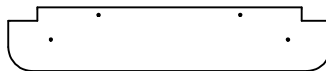

- (1) **K2 - LEMONADE STAND SHELF - W103252**  
5/8"x5 1/4"x26 7/8" (16x134x682)



- (2) **K6 - LEMONADE STAND SHELF - W103233**  
5/8"x5 1/4"x25 3/8" (16x134x644)

# Parts Identification

## Wood Components

(NOT TO SCALE)

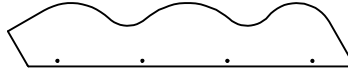

- (4) **K3 - RAFTER - W103194**  
5/8"x5 1/4"x28 7/8" (16x134x735)

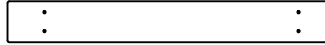

- (2) **M2 - BENCH SEAT - W102469**  
5/8"x3 3/8"x27 3/8" (16x86x694)



- (1) **N1 - TIE STRAP - W103362**  
5/8"x2 3/8"x47 1/8" (16x60x1198)



- (1) **N2 - TIE STRAP - W103361**  
5/8"x2 3/8"x45 7/8" (16x60x1164)



- (1) **N3 - TIE STRAP - W103403**  
5/8"x2 3/8"x47 1/8" (16x60x1198)



- (6) **N4 - TIE STRAP - W102424**  
5/8"x2"x3 1/8" (16x50x80)

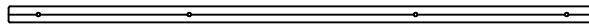

- (1) **O1 - SCREW BLOCK - W103197**  
5/8"x1 3/8"x49" (16x34x1245)

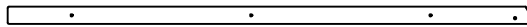

- (2) **P2 - POST - W103181**  
1 3/8"x1 3/8"x44" (36x36x1118)

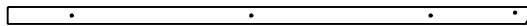

- (2) **P3 - FRONT RIGHT POST - W103180**  
1 3/8"x1 3/8"x44" (36x36x1118)

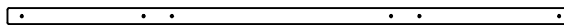

- (2) **T1 - TIE STRAP - W103192**  
1"x1 3/8"x47 1/8" (24x34x1198)

# Parts Identification

## Wood Components

(NOT TO SCALE)

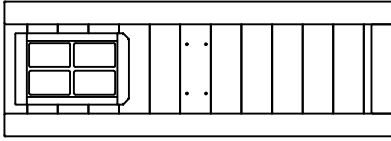

(2) WP5 - FRONT PANEL - W2A01656  
1 1/8"x14"x40 5/8" (27x356x1032)

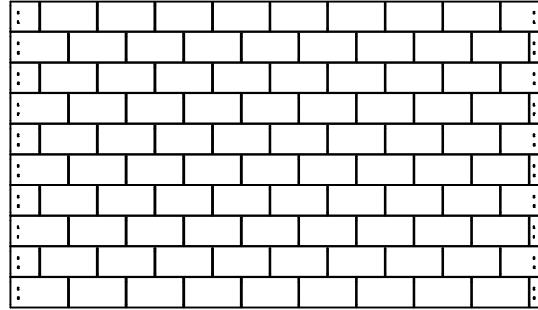

(2) RP1 - ROOF PANEL - W2A01665  
1 3/8"x31 7/8"x55 3/8" (35x809x1405)

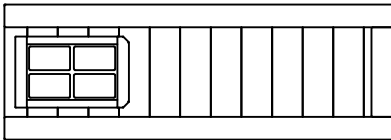

(2) WP4 - WINDOW PANEL - W2A01657  
1 1/8"x14"x40 5/8" (27x356x1032)

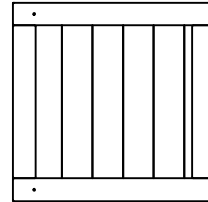

(1) WP1 - MIDDLE PANEL - W2A01659  
1 1/8"x20 5/8"x21" (27x524x534)

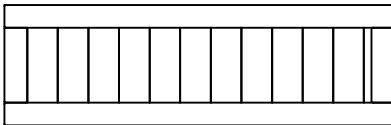

(4) WP2 - SIDE PANEL - W2A01658  
1 1/8"x12 1/2"x40 5/8" (27x318x1032)

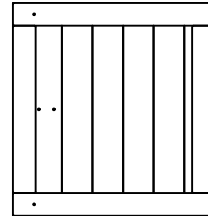

(1) WP3 - MIDDLE REAR PANEL - W2A01660  
1 1/8"x22 1/8"x21" (27x562x534)

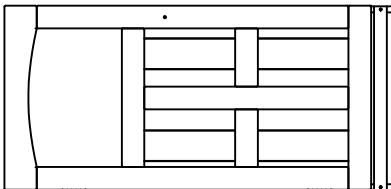

(1) DP1 - DOOR ASSEMBLY - W2A01663  
4 1/8"x19 1/8x 40 3/4" (105x486x1033)

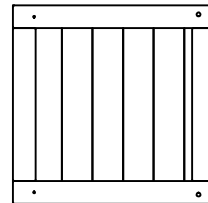

(1) WP7 - RIGHT MIDDLE PANEL - W2A01661  
1 1/8"x20 5/8"x21" (27x524x534)

# Parts Identification

## Hardware



(9) CK - SCREW PFH 8x2 - H100111



(68) BS - SCREW PFH 8x1 3/4 - H100089



(92) BP - SCREW PFH 8x1 1/2 - H100086



(9) BQ - SCREW PFH 8x1 1/4 - H100087



(4) BR - SCREW PFH 8x1 1/8 - H100088



(2) CV - SCREW PFH 8x1/2 - H100124



(35) SM - LAG SCREW WH PH 10x2-1/2 - H100177



(6) TV - SCREW PWH 8x1-5/8 - H100181



(4) TS - SCREW PWH 8x1-1/4 - H100180



(17) BC - SCREW PWH 8x3/4 - H100070



(4) CY - SCREW PWH 8x5/8 - H100128



(4) CT - SCREW TAPPING 8x1/2 - H100123

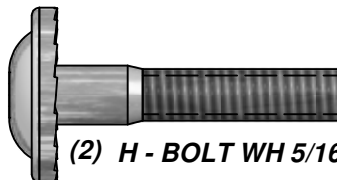

(2) H - BOLT WH 5/16x1 1/2 - H100010

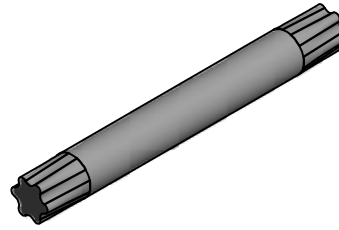

(2) - T-40 TORX BIT - A100042



(35) SN - WASHER LOCK EXT 5x11 - H100178

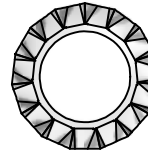

(4) AD - WASHER LOCK EXT 12x19 - H100031

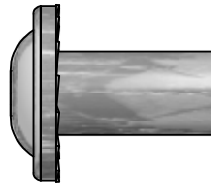

(2) D - NUT BARREL WH 5/16x7/8 - H100005

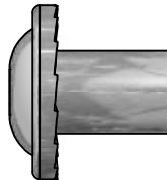

(2) B - NUT BARREL WH 5/16x5/8 - H100004

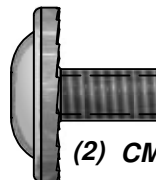

(2) CM - BOLT WH 5/16x1/2 - H100115



(2) - T-40 TORX WRENCH - A100041



# Parts Identification

## Accessories

(NOT TO SCALE)



(1) SR - "B" REVISION TAG - A100315

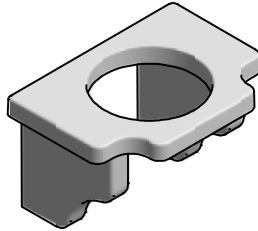

(2) - FLOWER POT HOLDER - A6P00023

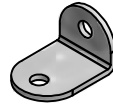

(2) FZ - L BRACKET WHITE 32x51 - A100133

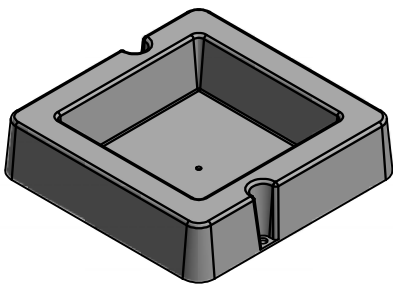

(1) - SURFACE MOUNT BASIN - A6P00032

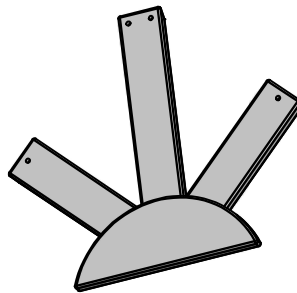

(2) VB - PLASTIC SUNBURST - A100361



(1) HZ - KNOB - A100071

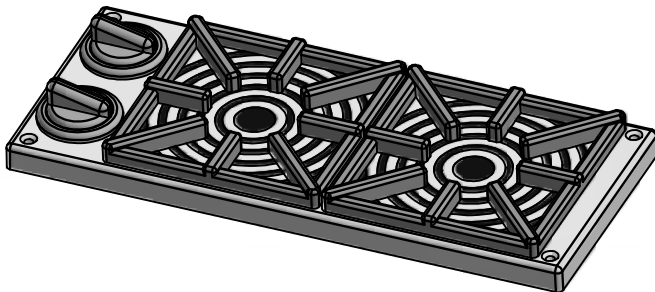

(1) - STOVE KIT - A6P00025

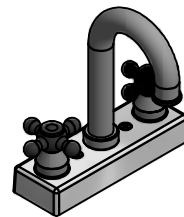

(1) - FAUCET KIT - A6P00024



(1) - LTP ID TAG (SMALL) WITH AGES - A4M00515



(1) MV - METAL TIE STRAP - A100257

# Parts Identification

## Accessories

(NOT TO SCALE)

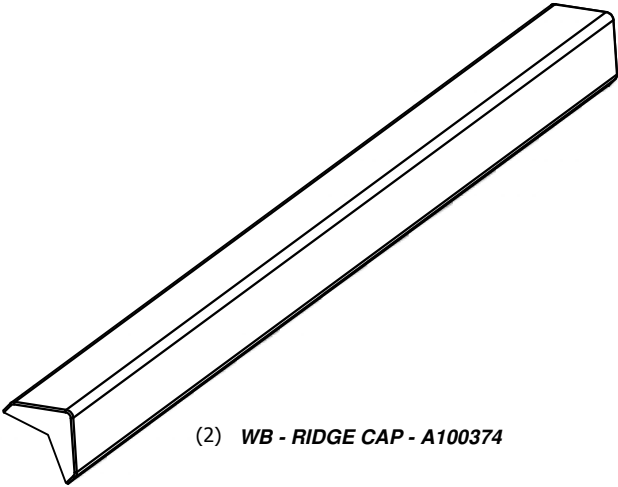

(2) *WB - RIDGE CAP - A100374*

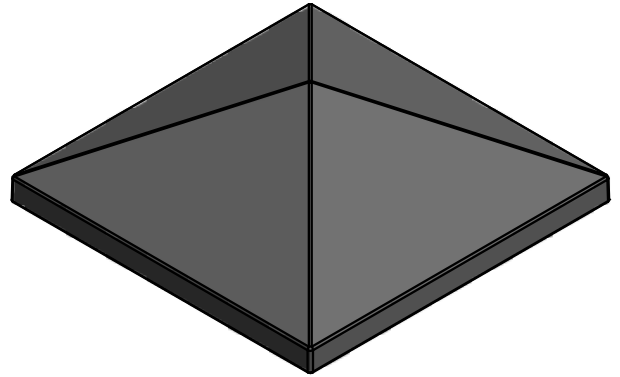

(1) *WE - CUPOLA ROOF - A100386*

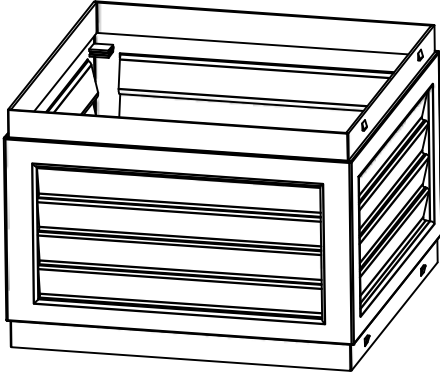

(1) *WD - CUPOLA LOUVER - A100385*

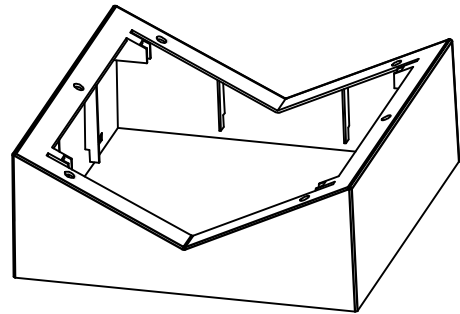

(1) *WC - CUPOLA BASE - A100384*

**STEP 1**

**USING THE DIAGRAM BELOW, POSITION PLAYHOUSE PANELS AND PARTS EXTERIOR SURFACE FACE DOWN AS SHOWN FOR EASE OF ASSEMBLY.**

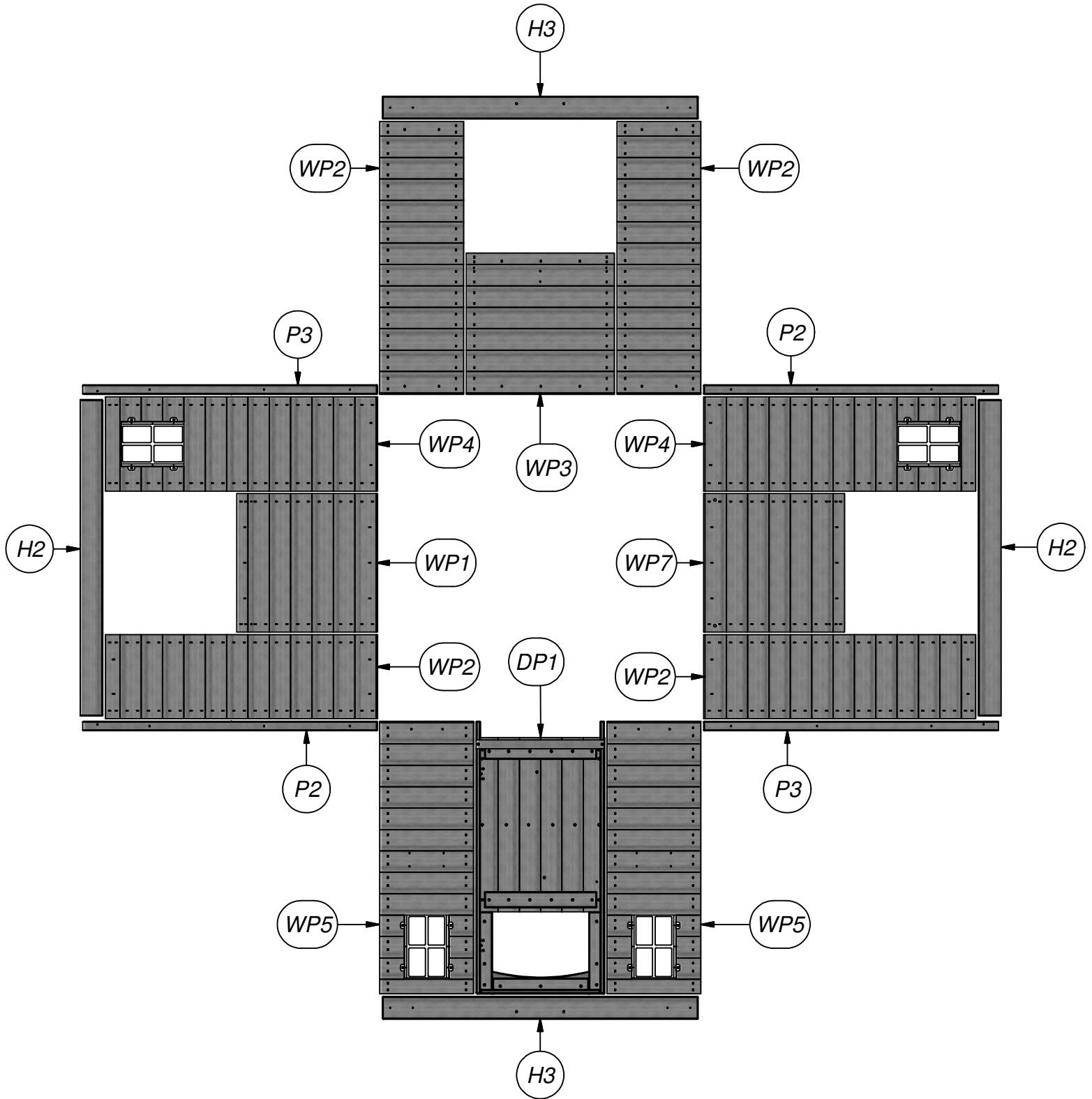

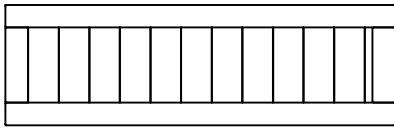

(1) WP2 - SIDE PANEL- W2A01658  
1 1/8"x12 1/2"x40 5/8" (27x318x1032)

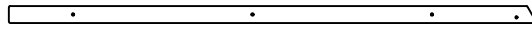

(1) P2 - POST - W103181  
1 3/8"x1 3/8"x44" (36x36x1118)

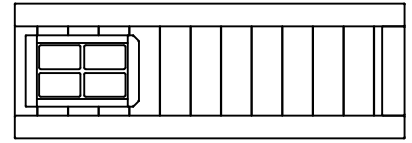

(1) WP4 - WINDOW PANEL- W2A01657  
1 1/8"x14"x40 5/8" (27x356x1032)

**STEP 2**

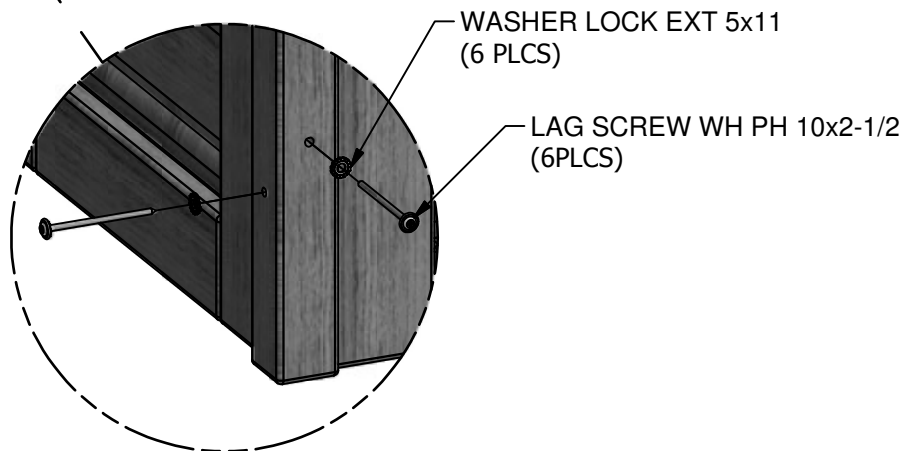
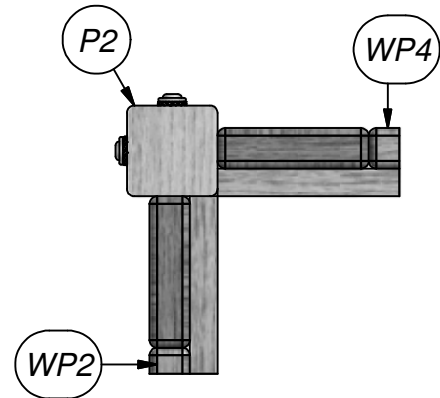
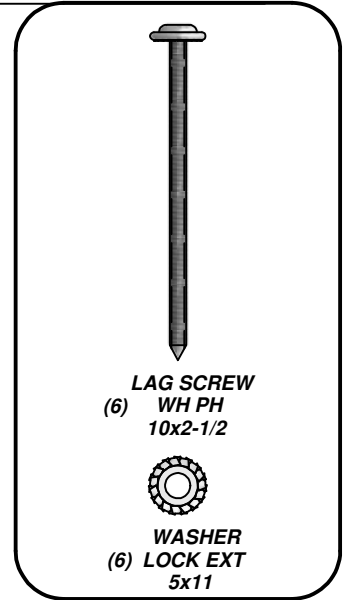

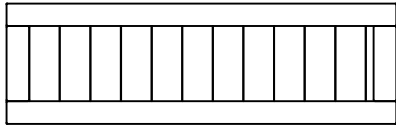

(1) WP2 - SIDE PANEL - W2A01658  
1 1/8"x12 1/2"x40 5/8" (27x318x1032)

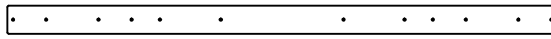

(1) N2 - TIE STRAP - W103361  
5/8"x2 3/8"x45 7/8" (16x60x1164)

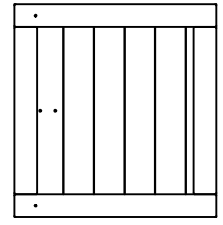

(1) WP3 - MIDDLE REAR PANEL - W2A01660  
1 1/8"x22 1/8"x21" (27x562x534)

### STEP 3

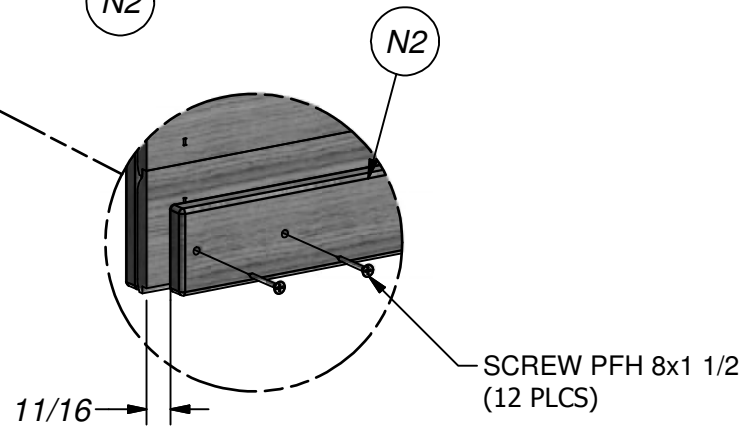
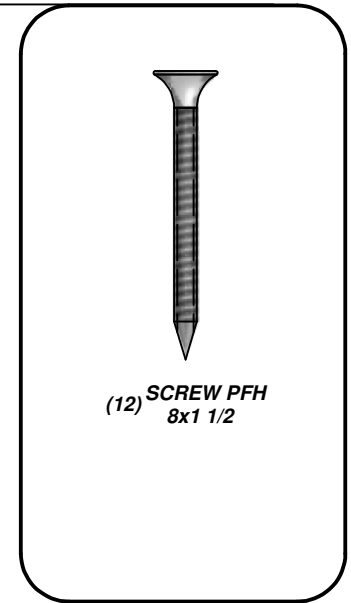
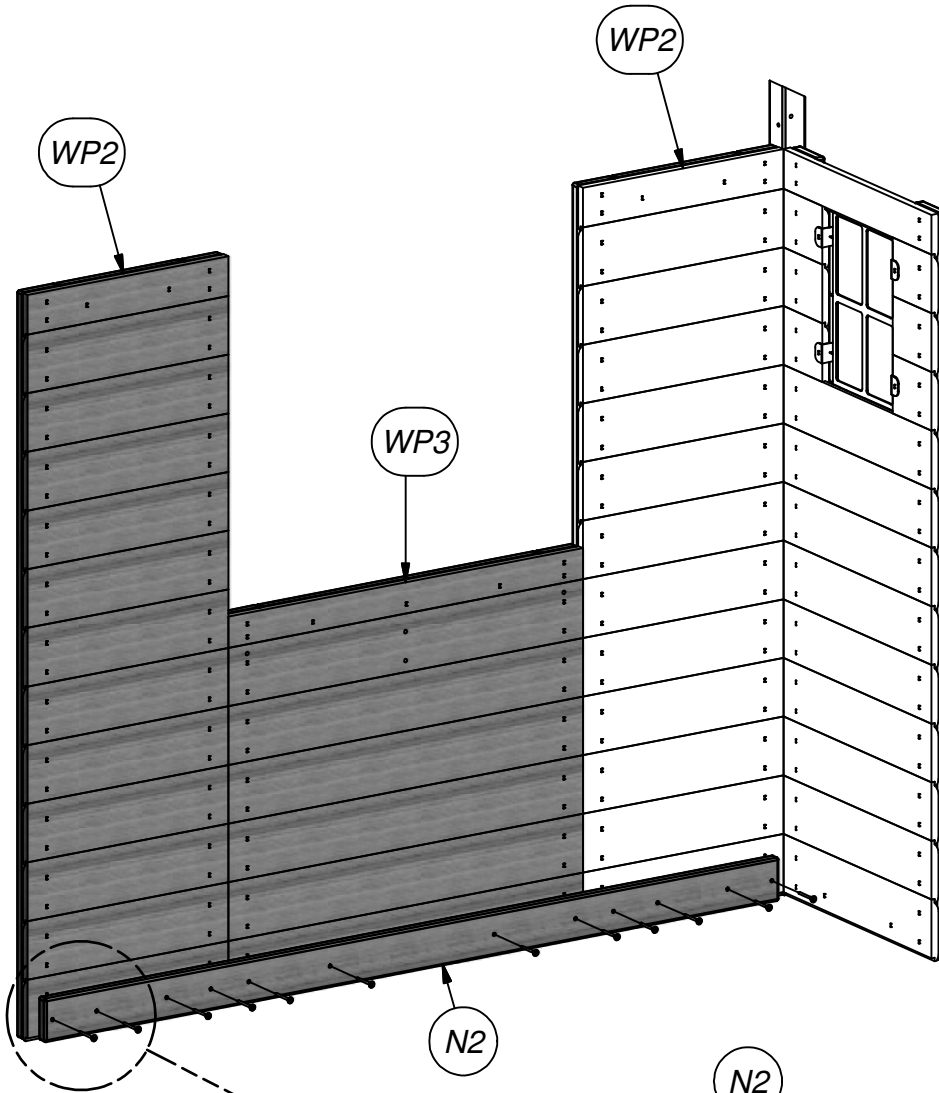

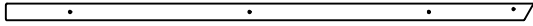

(1) **P3 - FRONT RIGHT POST - W103180**  
1 3/8"x1 3/8"x44" (36x36x1118)

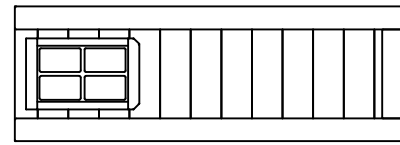

(1) **WP4 - WINDOW PANEL - W2A01657**  
1 1/8"x14"x40 5/8" (27x356x1032)

**STEP 4**

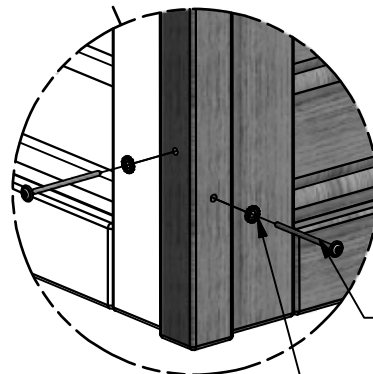
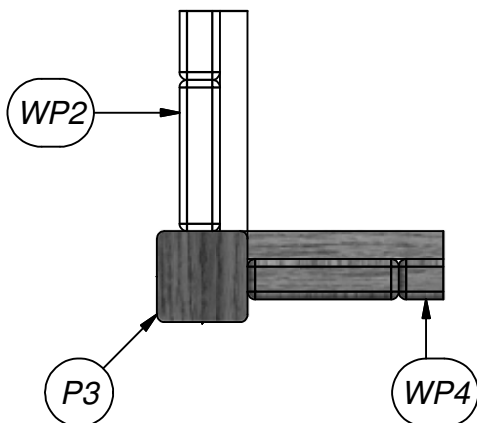
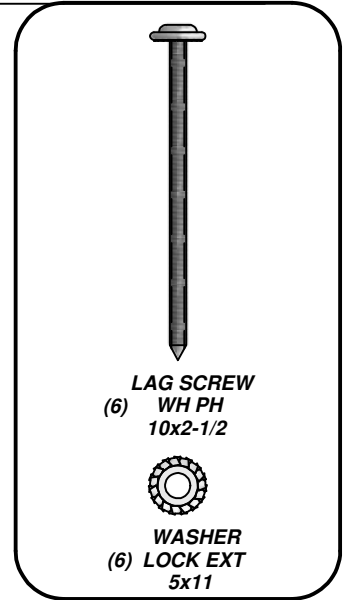
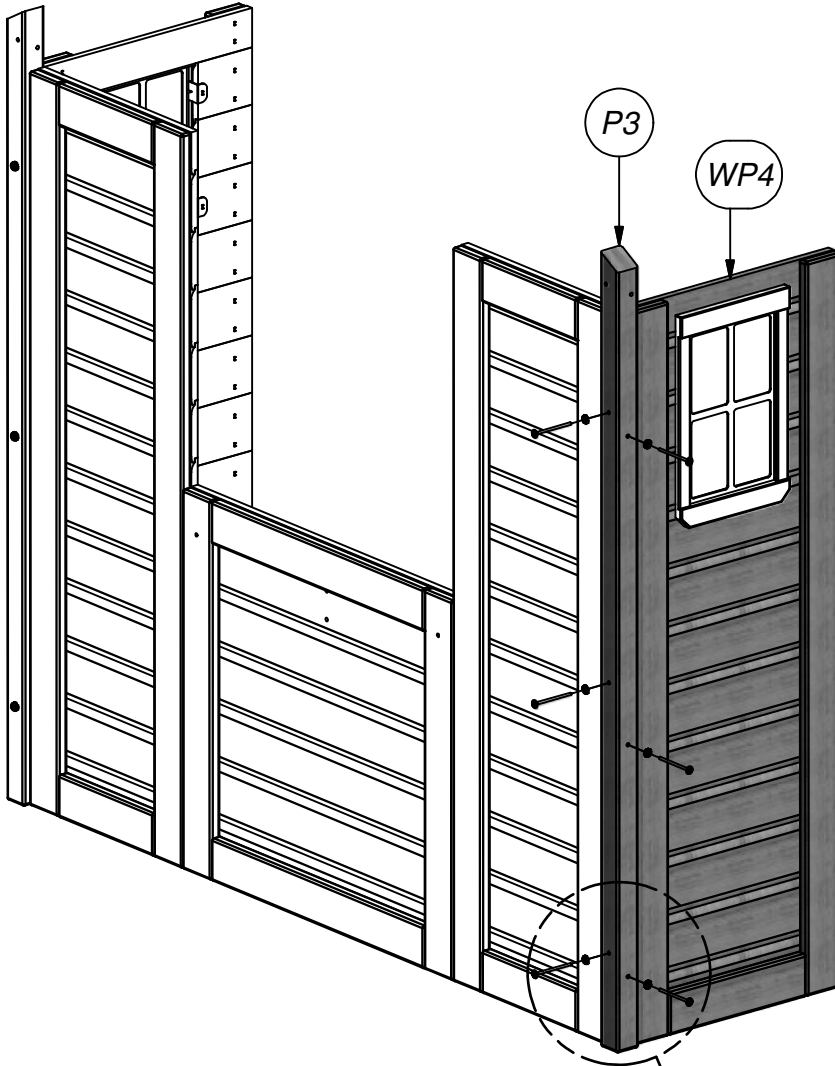

LAG SCREW WH PH 10x2-1/2 (6 PLCS)  
WASHER LOCK EXT 5x11 (6 PLCS)

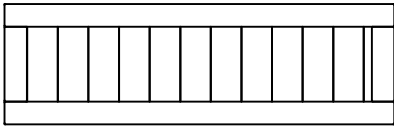

(1) WP2 - SIDE PANEL - W2A01658  
1 1/8"x12 1/2"x40 5/8" (27x318x1032)

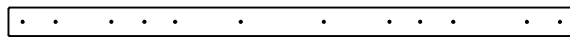

(1) N1 - TIE STRAP - W103362  
5/8"x2 3/8"x47 1/8" (16x60x1198)

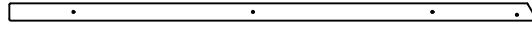

(1) P2 - POST - W103181  
1 3/8"x1 3/8"x44" (36x36x1118)

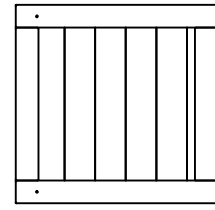

(1) WP1 - MIDDLE PANEL - W2A01659  
1 1/8"x20 5/8"x21" (27x524x534)

### STEP 5

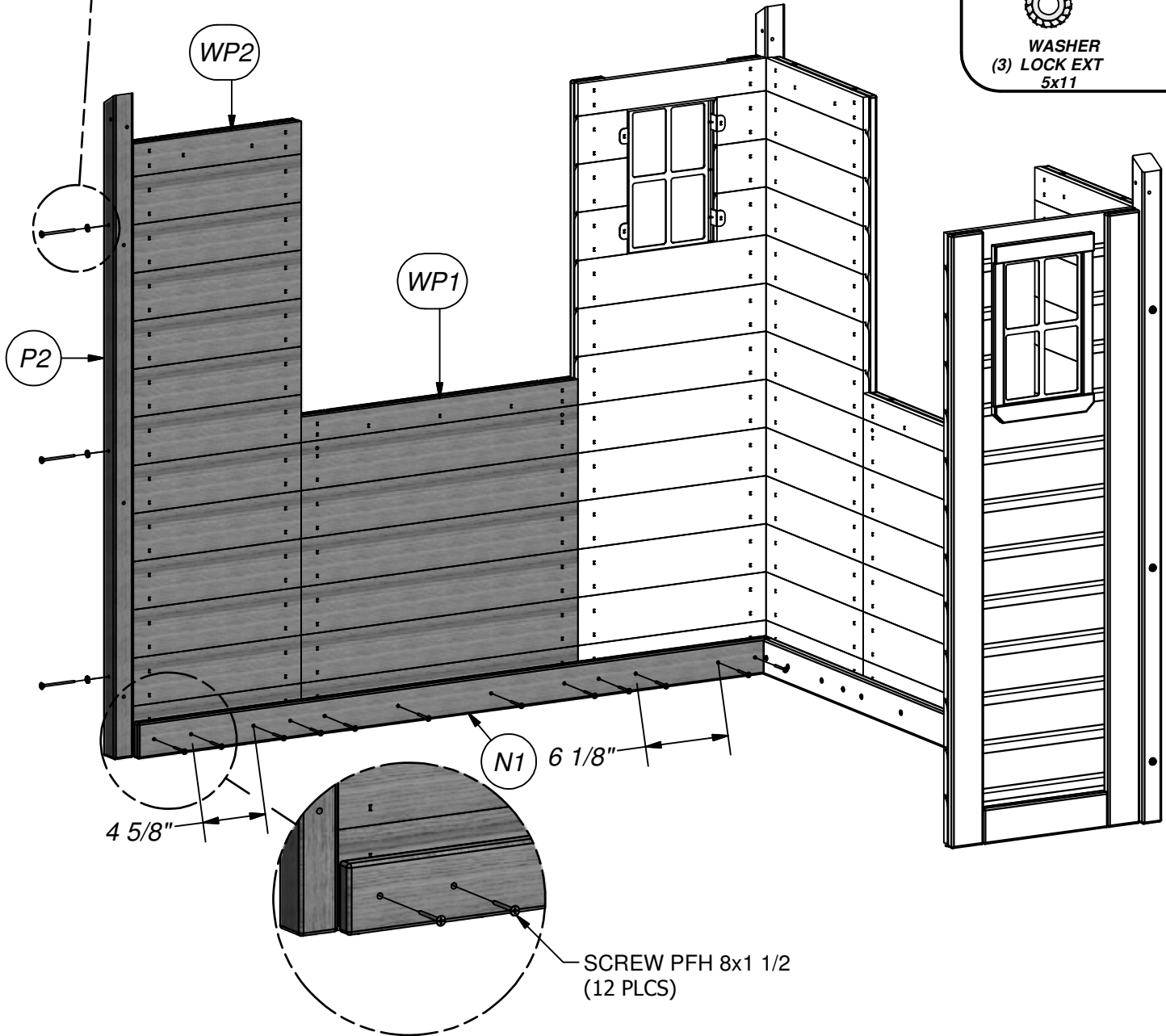
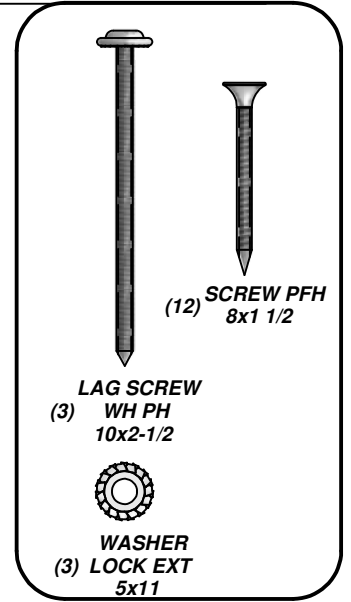
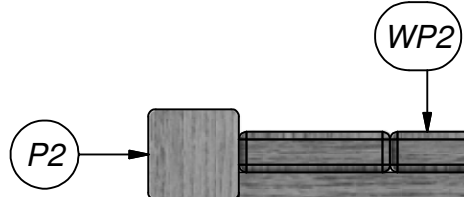
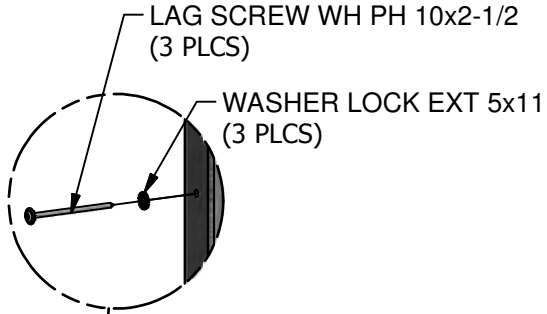

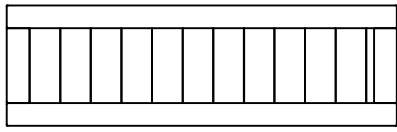

(1) WP2 - SIDE PANEL - W2A01658  
1 1/8"x12 1/2"x40 5/8" (27x318x1032)

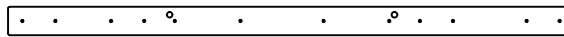

(1) N3 - TIE STRAP - W103403  
5/8"x2 3/8"x47 1/8" (16x60x1198)

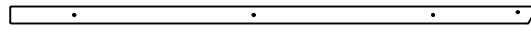

(1) P3 - FRONT RIGHT POST - W103180  
1 3/8"x1 3/8"x44" (36x36x1118)

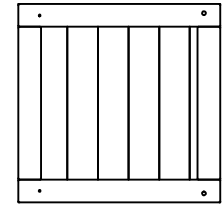

(1) WP7 - RIGHT MIDDLE PANEL - W2A01661  
1 1/8"x20 5/8"x21" (27x524x534)

### STEP 6

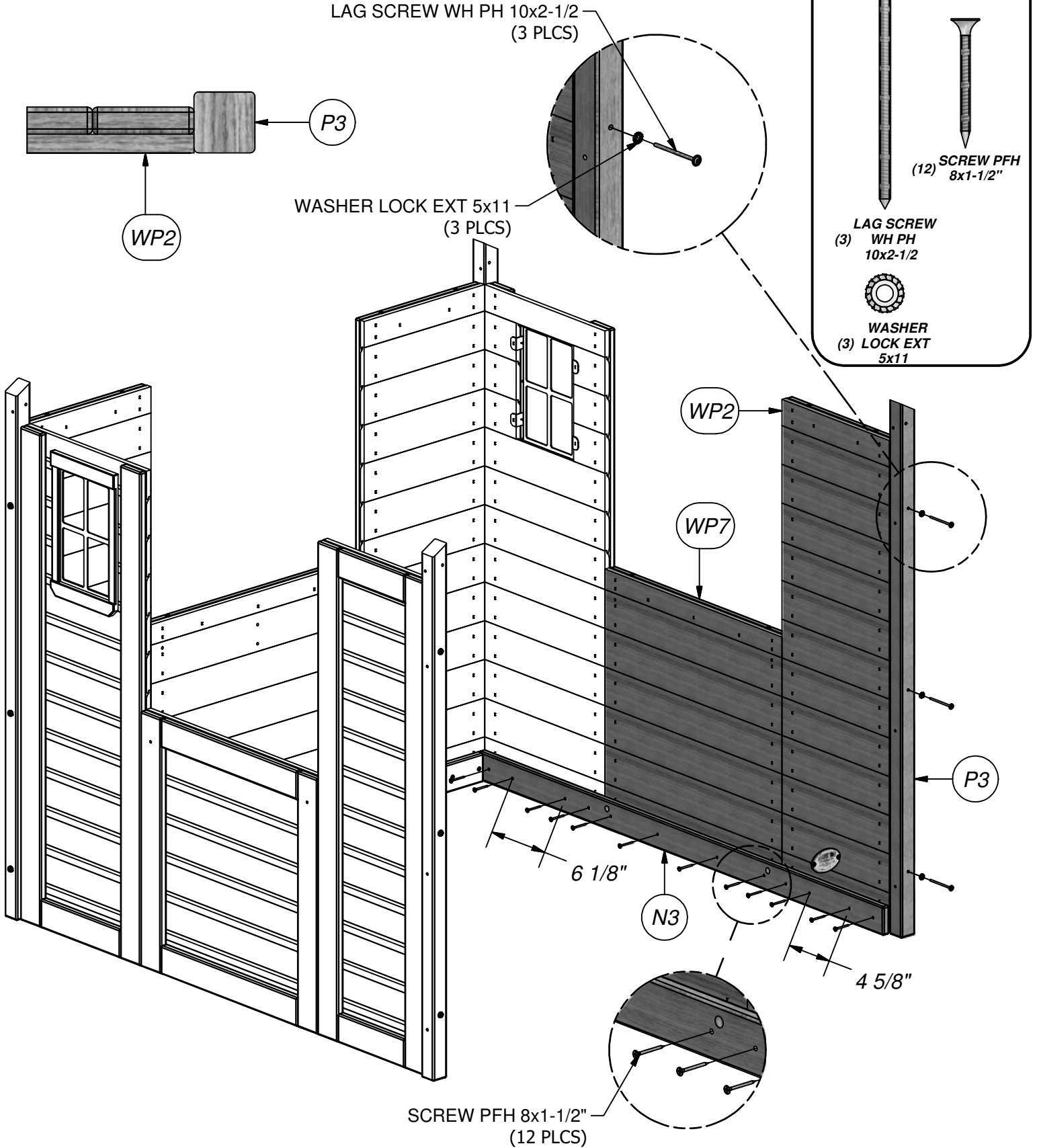



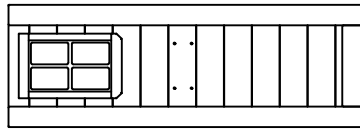
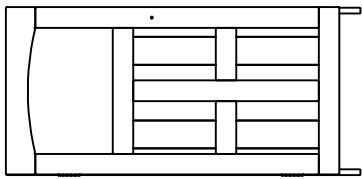

(1) HZ - KNOB - A100071

(1) DP1 - DOOR ASSEMBLY- W2A01663  
4 1/8"x19 1/8x 40 3/4" (105x486x1033)

(2) WP5 - FRONT PANEL- W2A01656  
1 1/8"x14"x40 5/8" (27x356x1032)



(1) MV - METAL TIE STRAP - A100257

**STEP 7**

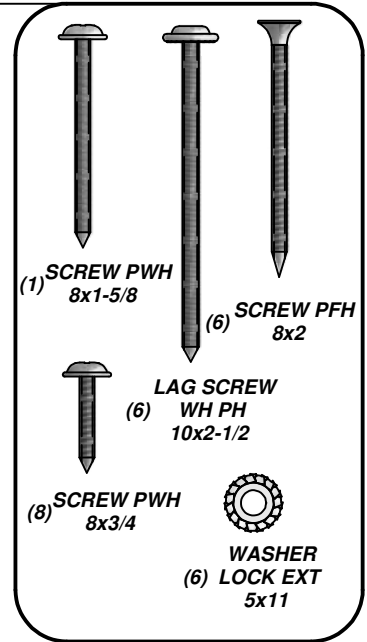
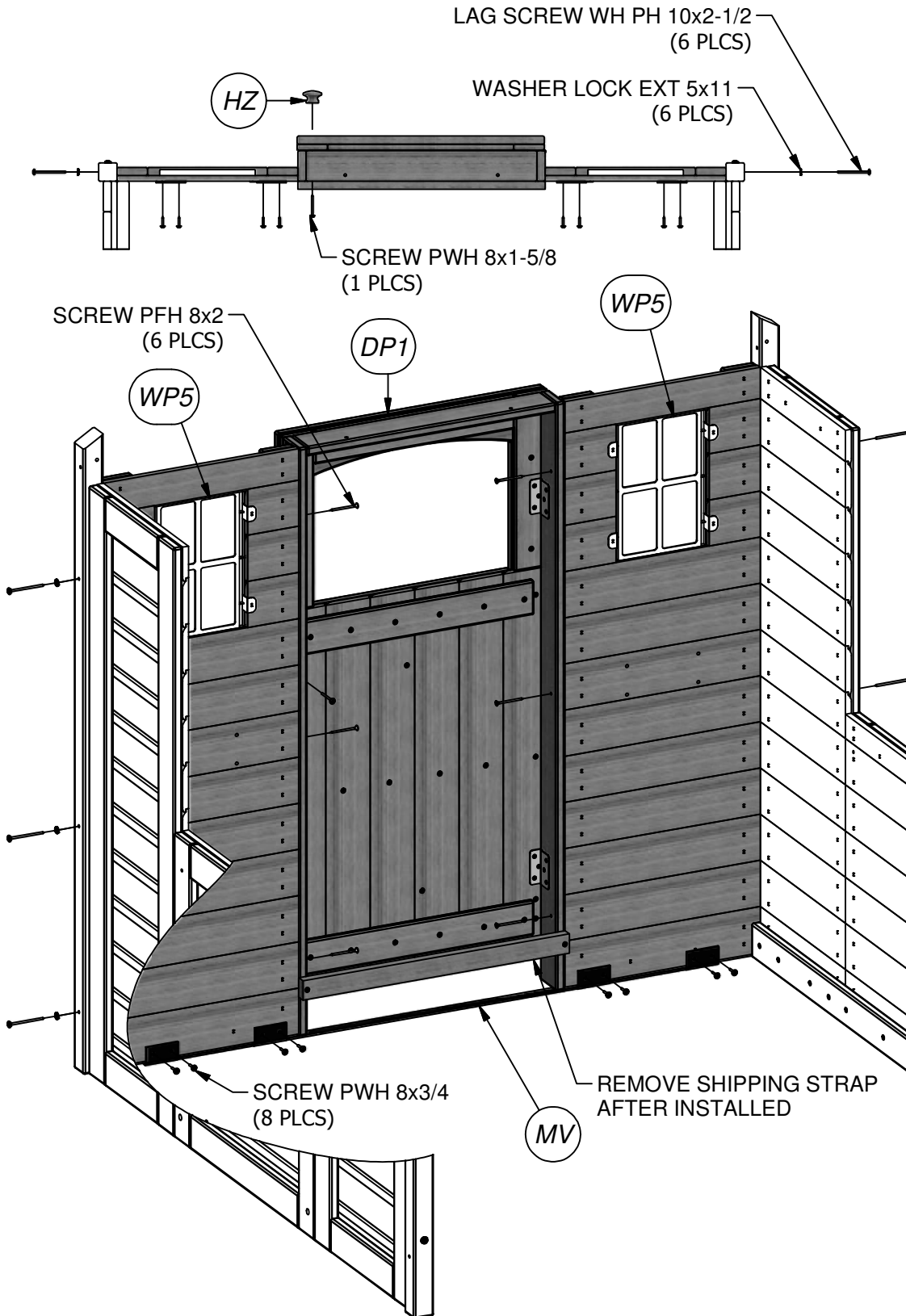

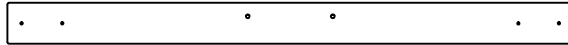

(1) **H3 - HEADER - W103190**  
1"x3 3/8"x47 1/8" (24x86x1198)

**STEP 8**

LAG SCREW WH PH 10x2-1/2  
(2 PLCS)  
WASHER LOCK EXT 5x11  
(2 PLCS)

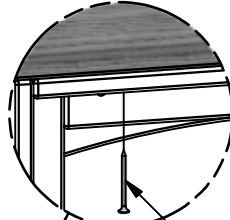

SCREW PFH 8x2  
(2 PLCS)

H3

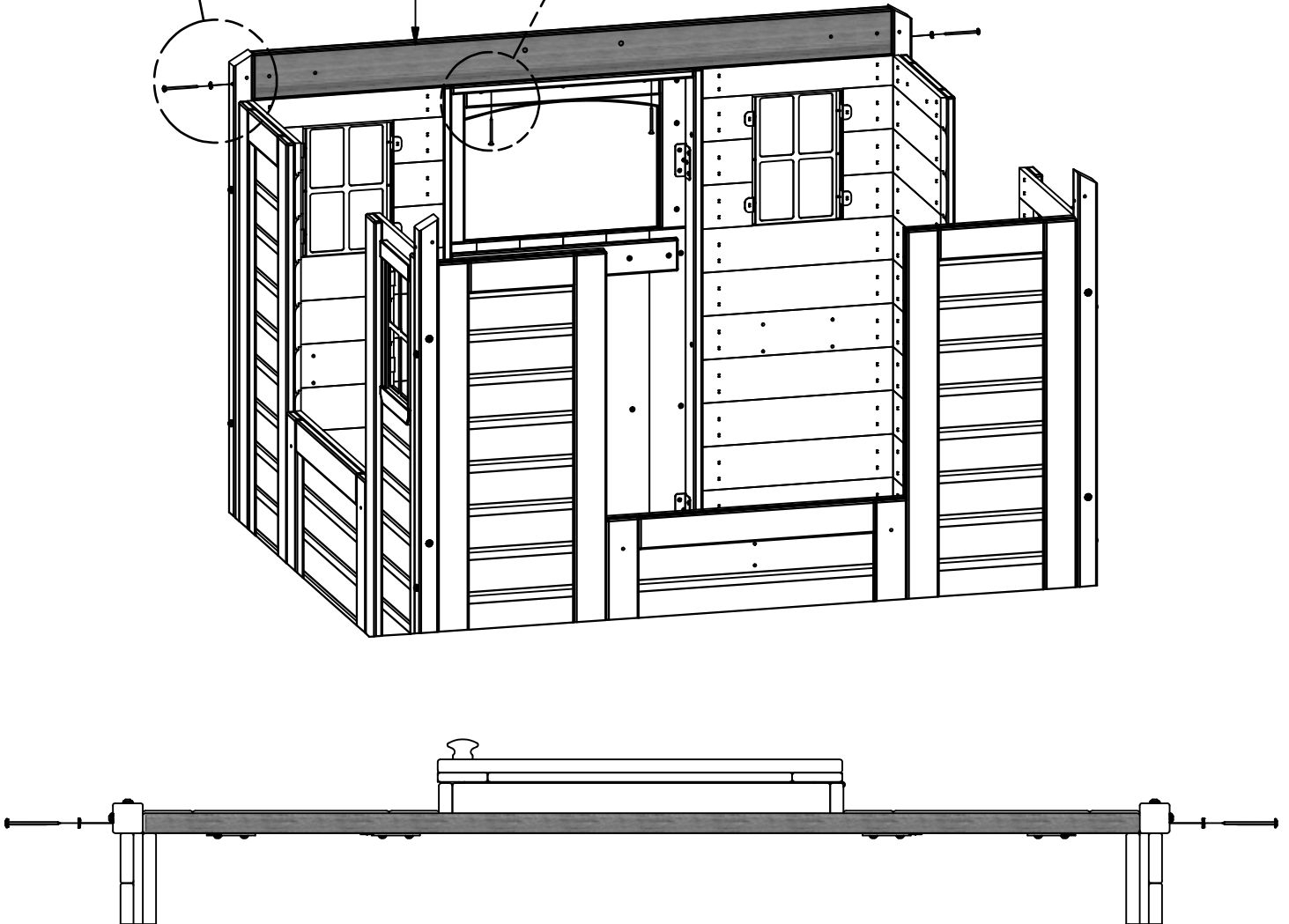
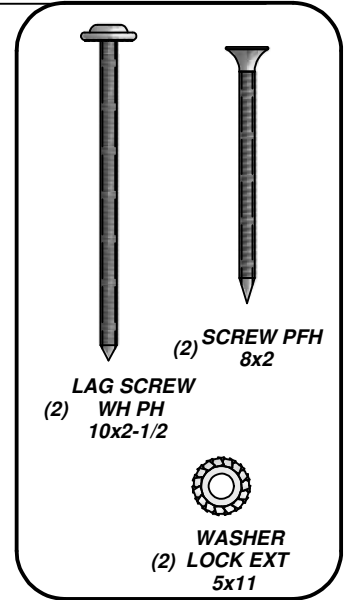

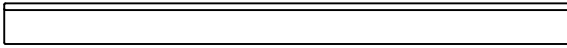

(1) **H2 - ANGLED HEADER - W103189**  
 1"x3 3/8"x47 1/8" (24x86x1198)

(2) **N4 - TIE STRAP - W102424**  
 5/8"x2"x3 1/8" (16x50x80)

**STEP 9**

LAG SCREW WH PH 10x2-1/2  
 (2 PLCS)  
 WASHER LOCK EXT 5x11  
 (2 PLCS)

9/16"

1 13/16"

N4

SCREW PFH 8x1 1/2  
 (8 PLCS)

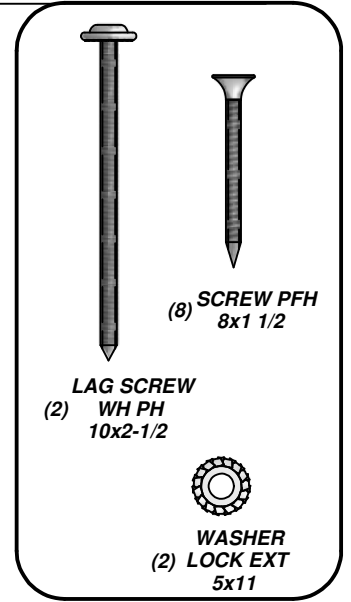

N4

H2

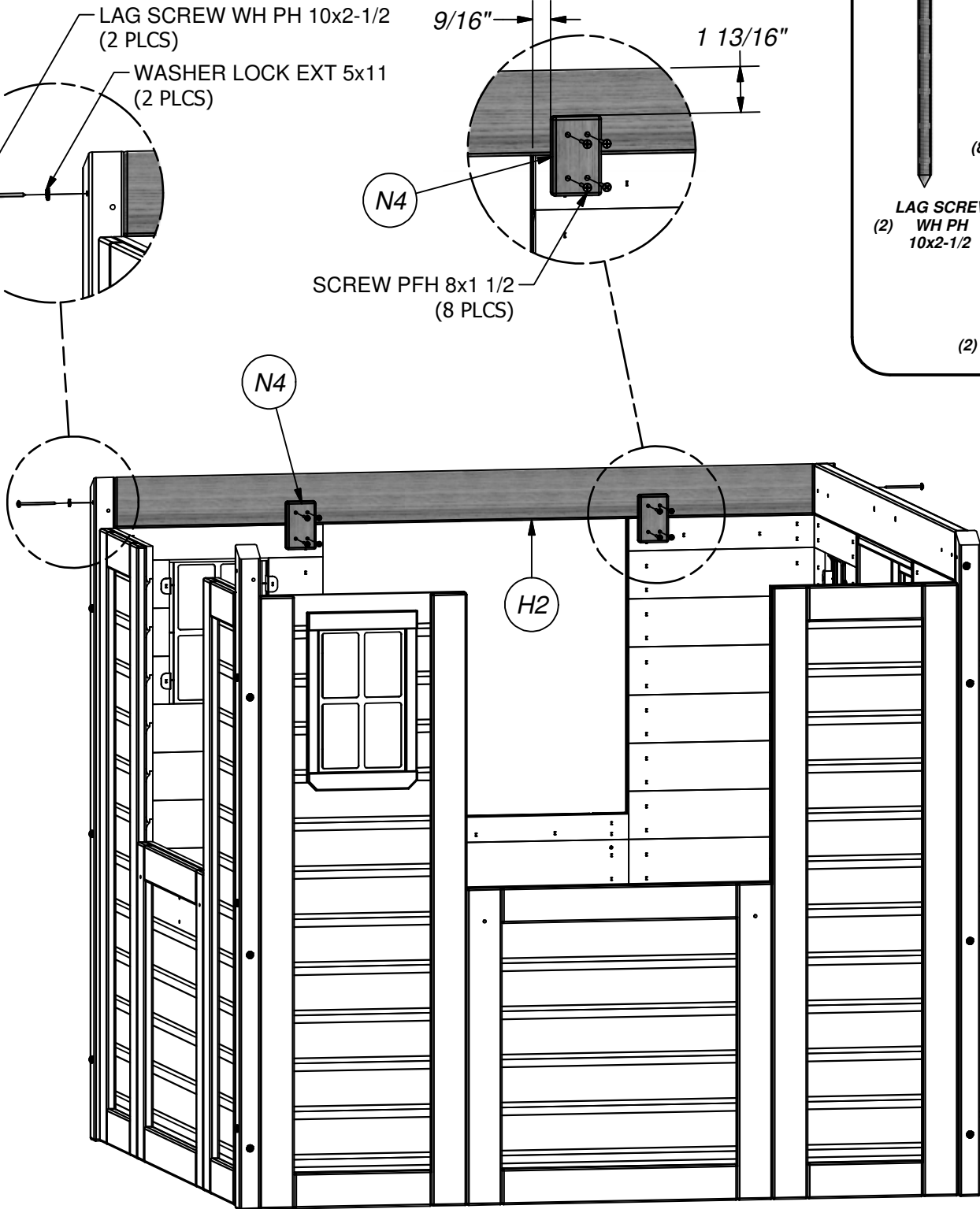

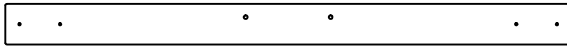

(1) **H3 - HEADER - W103190**  
1"x3 3/8"x47 1/8" (24x86x1198)

(2) **N4 - TIE STRAP - W102424**  
5/8"x2"x3 1/8" (16x50x80)

### STEP 10

LAG SCREW WH PH 10x2-1/2  
(2 PLCS)  
WASHER LOCK EXT 5x11  
(2 PLCS)

9/16" 1 13/16"

N4

SCREW PFH 8x1 1/2  
(8 PLCS)

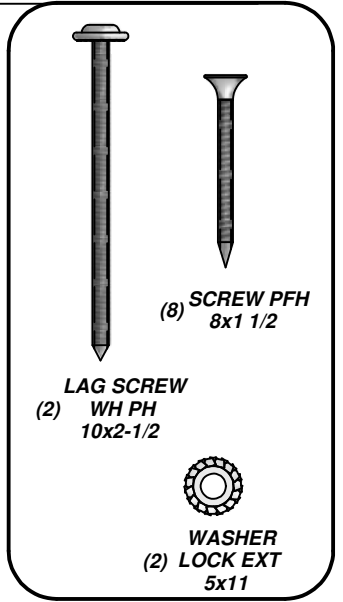

H3

N4

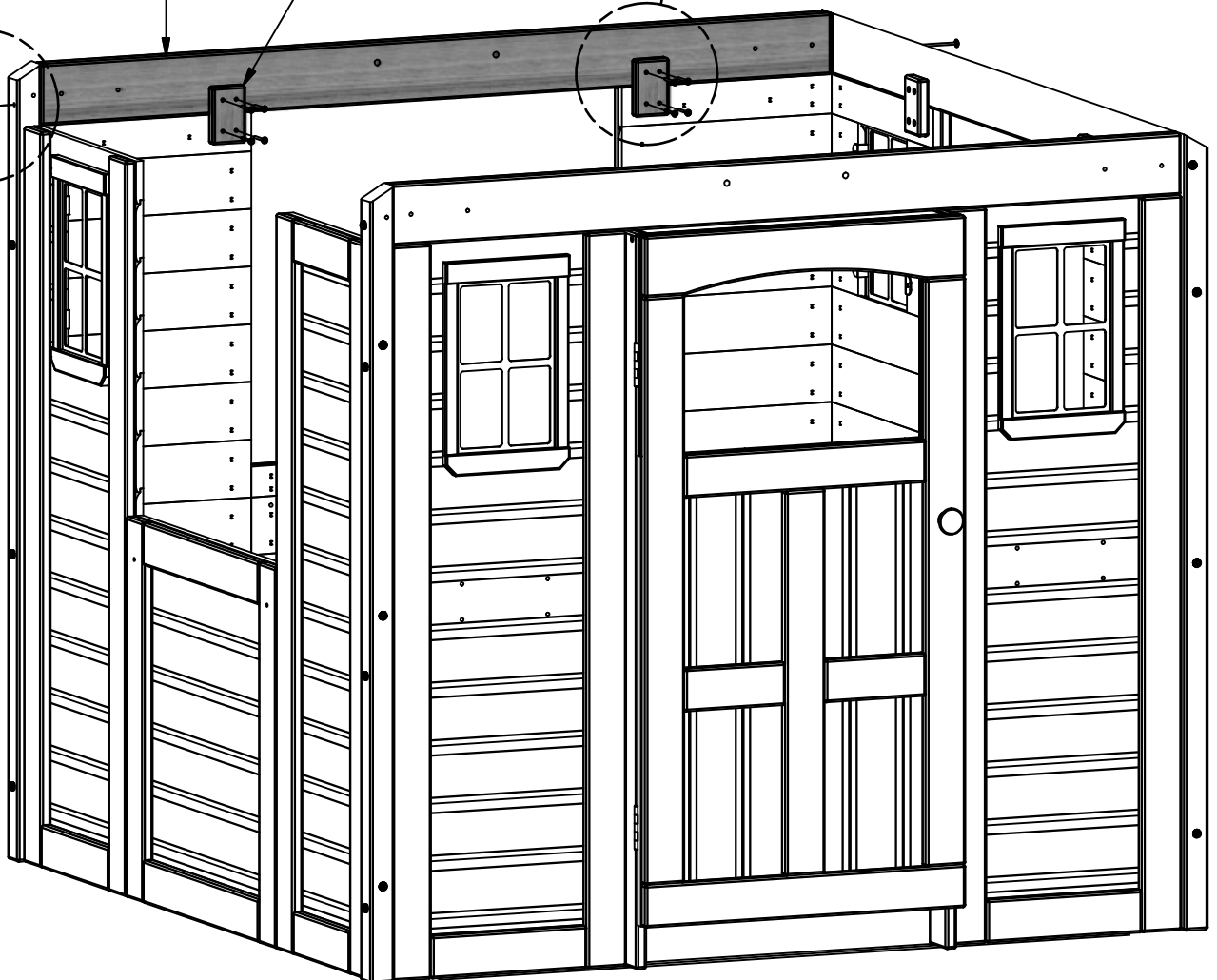

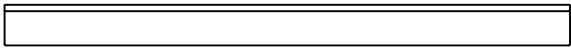

(1) **H2 - ANGLED HEADER - W103189**  
 1"x3 3/8"x47 1/8" (24x86x1198)

(2) **N4 - TIE STRAP - W102424**  
 5/8"x2"x3 1/8" (16x50x80)

**STEP 11**

LAG SCREW WH PH 10x2-1/2  
 (2 PLCS)

WASHER LOCK EXT 5x11  
 (2 PLCS)

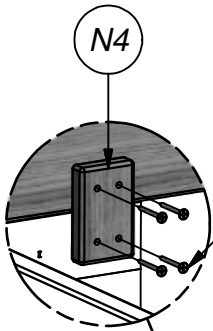

N4

SCREW PFH 8x1 1/2  
 (8 PLCS)

H2

N4

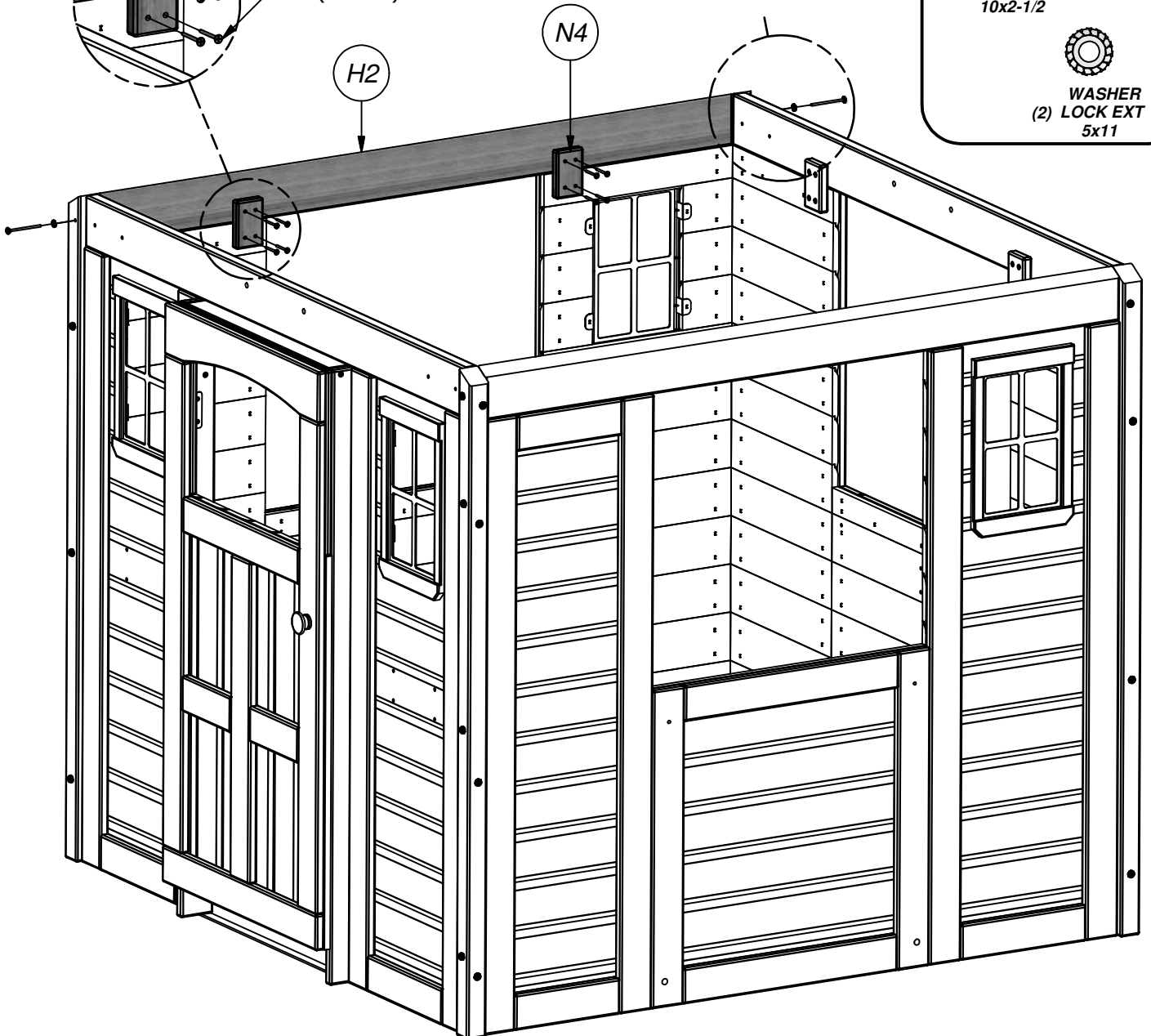
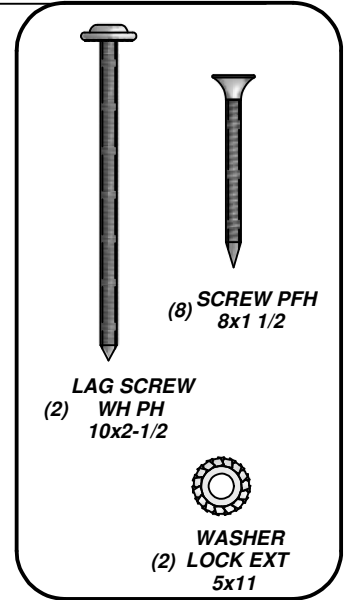
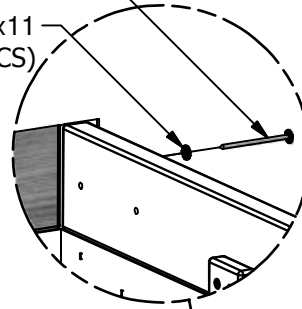

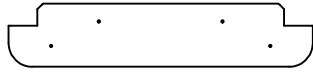

(1) **K6 - LEMONADE STAND SHELF - W103233**  
5/8"x5 1/4"x25 3/8" (16x134x644)



(2) **H1 - SHELF SUPPORT - W4L05264**  
1"x3 3/8"x3 3/8" (24x86x86)

## STEP 12

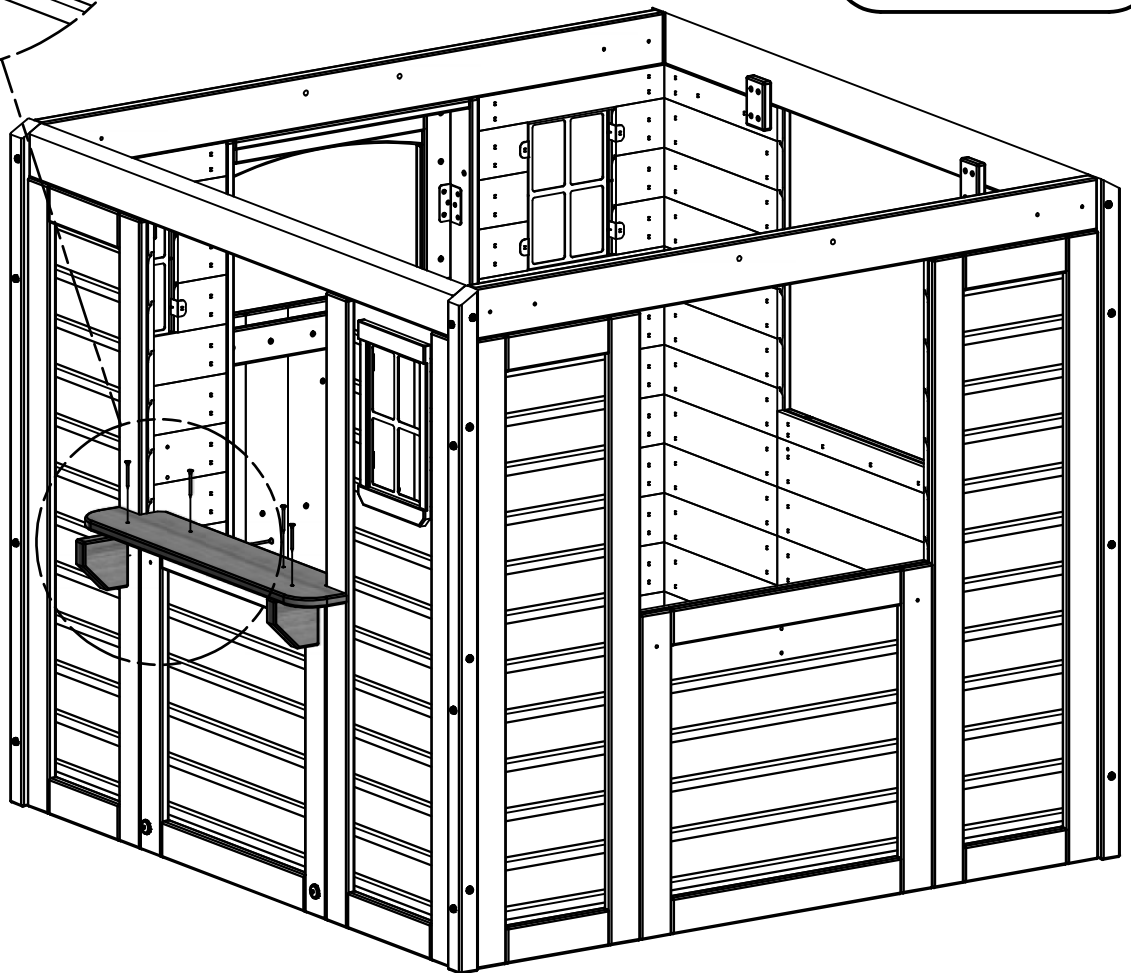
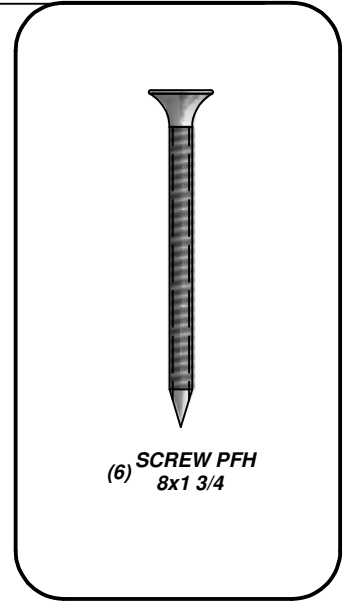
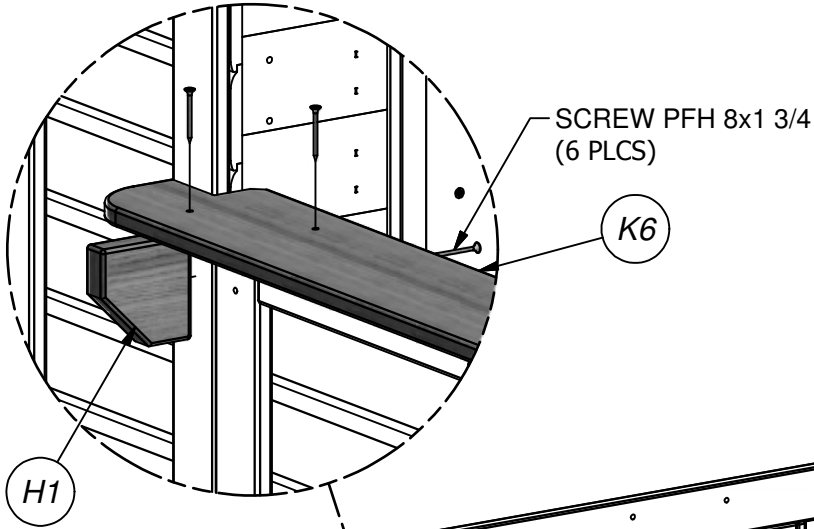



(2) **H1 - SHELF SUPPORT - W4L05264**  
1"x3 3/8"x3 3/8" (24x86x86)

(1) **K2 - LEMONADE STAND SHELF - W103252**  
5/8"x5 1/4"x26 7/8" (16x134x682)

**STEP 13**

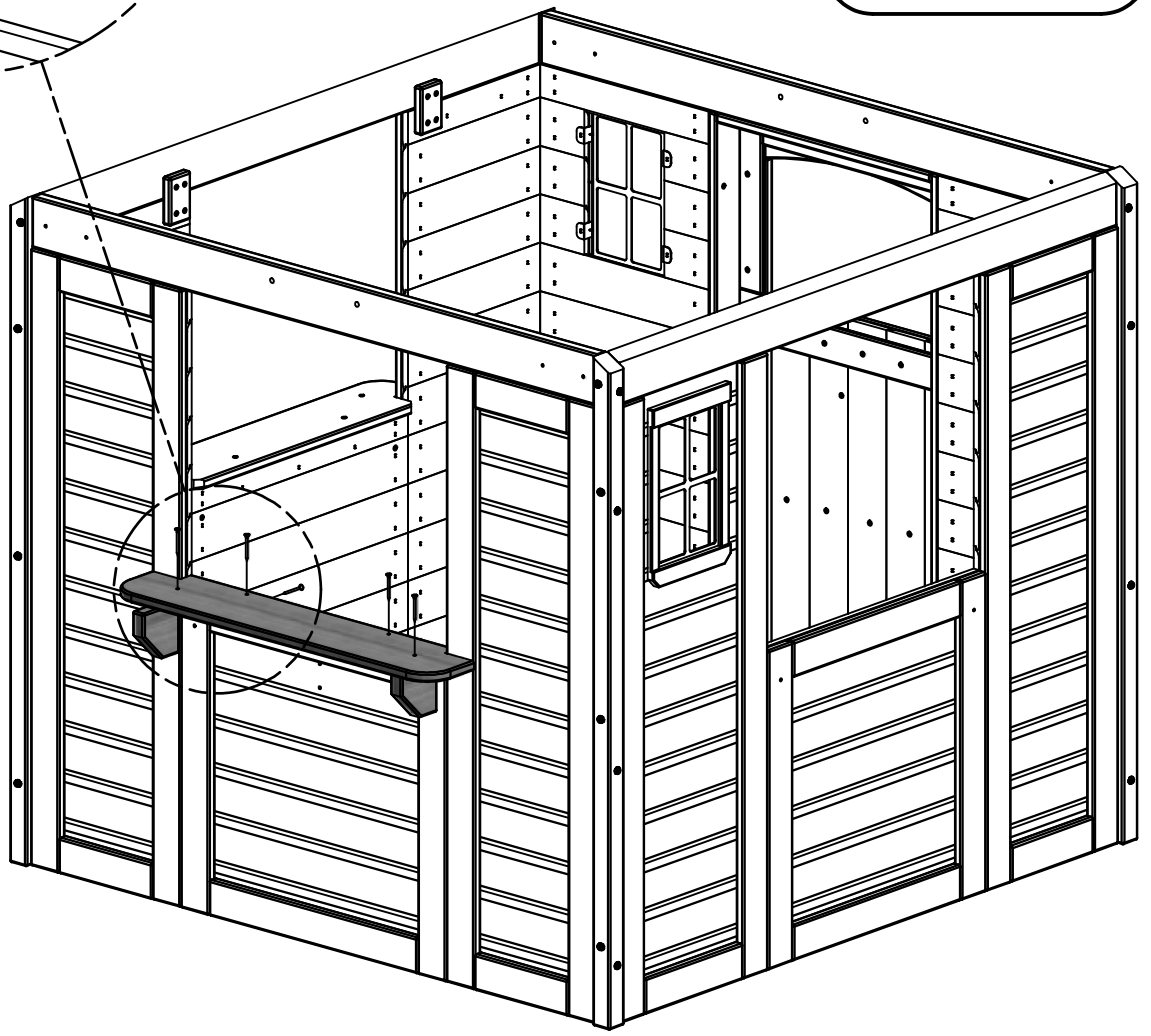
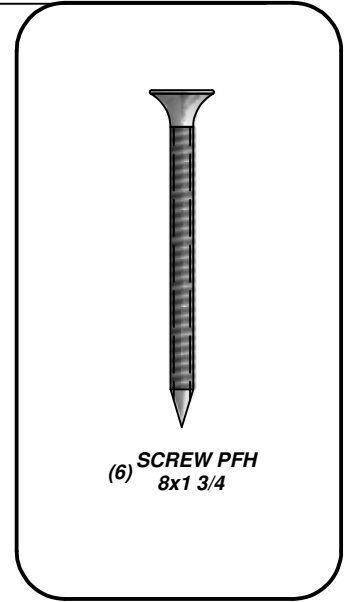
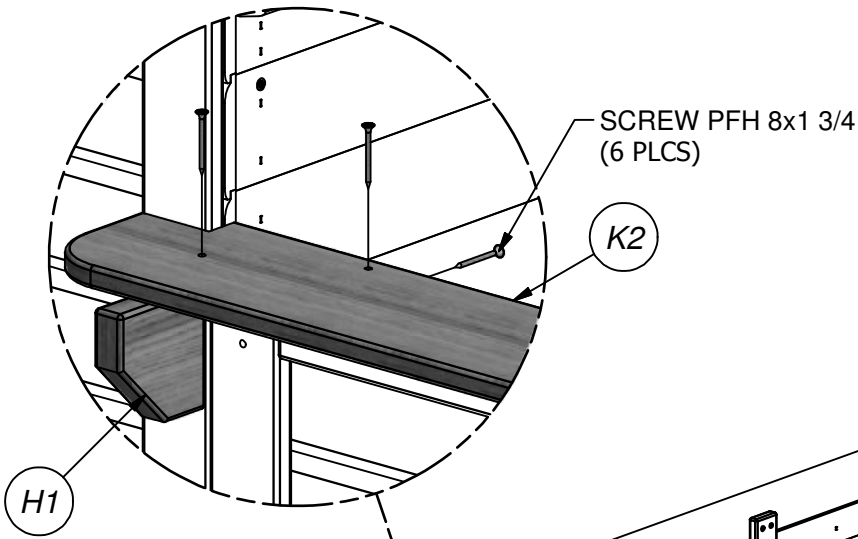

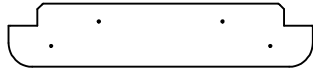

(1) **K6 - LEMONADE STAND SHELF - W103233**  
5/8"x5 1/4"x25 3/8" (16x134x644)



(2) **H1 - SHELF SUPPORT - W4L05264**  
1"x3 3/8"x3 3/8" (24x86x86)

## STEP 14

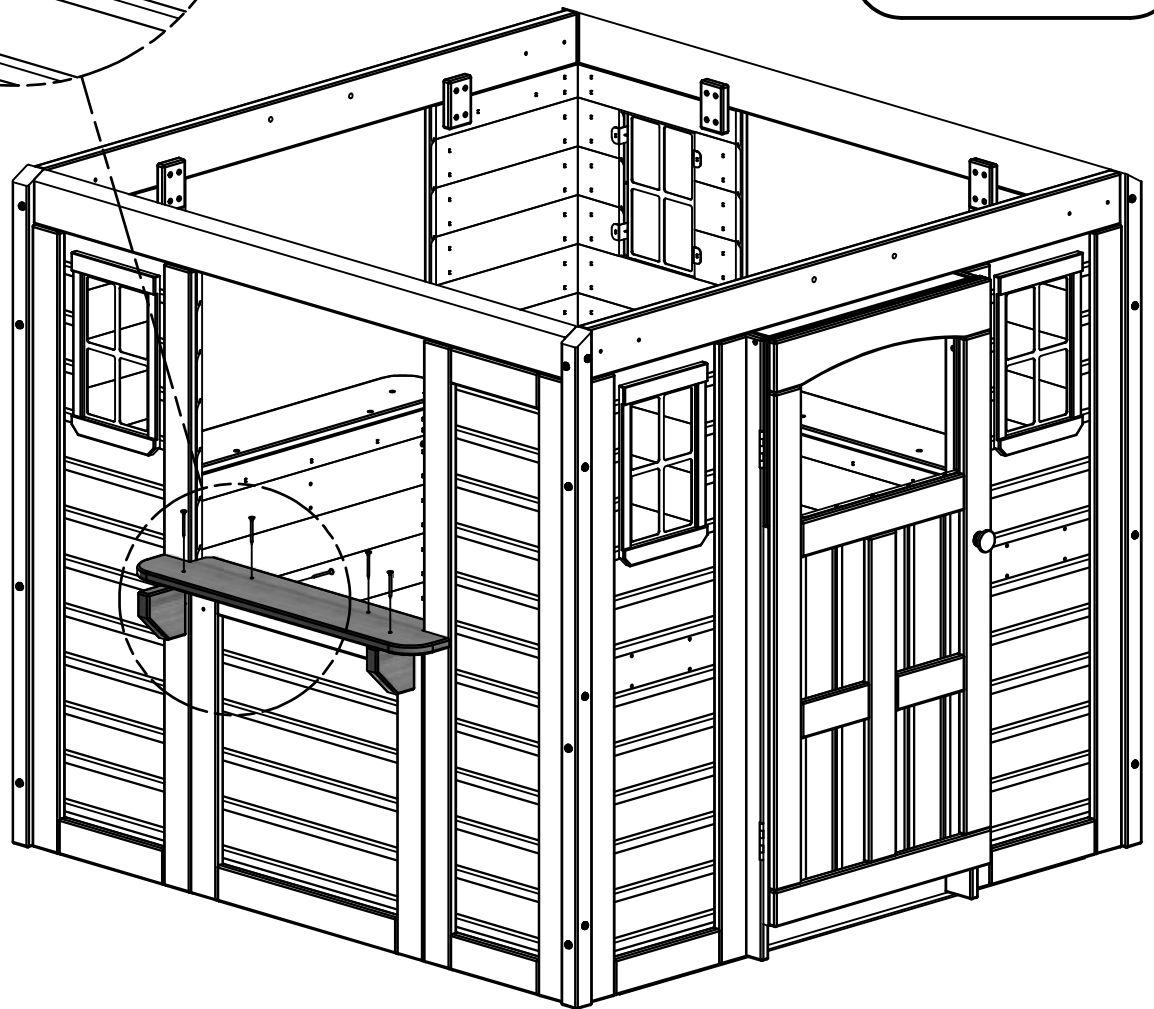
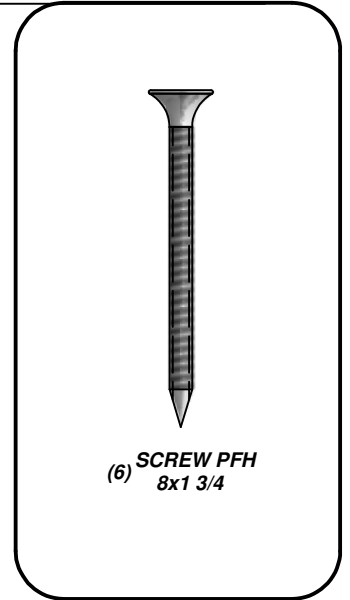
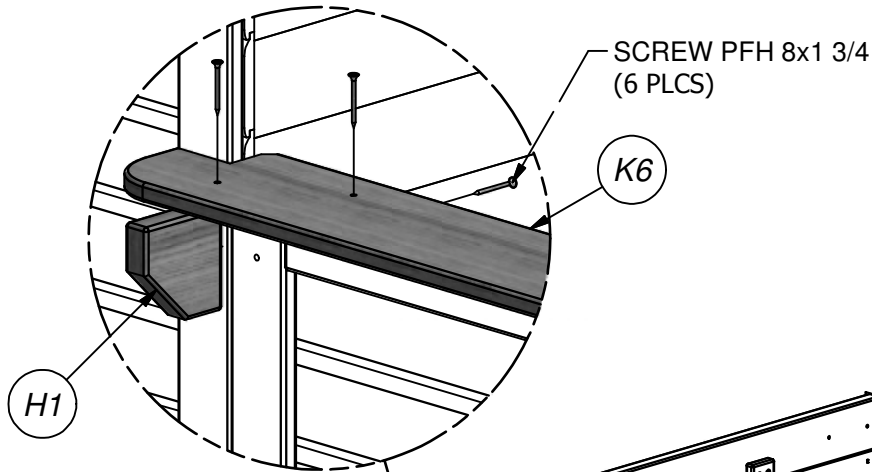



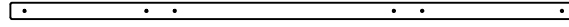

(1) T1 - TIE STRAP - W103192  
1"x1 3/8"x47 1/8" (24x34x1198)

**STEP 15**

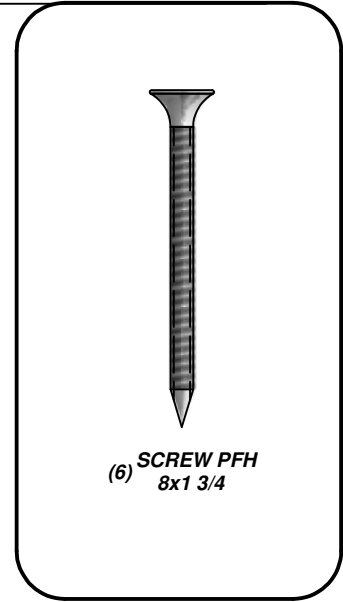
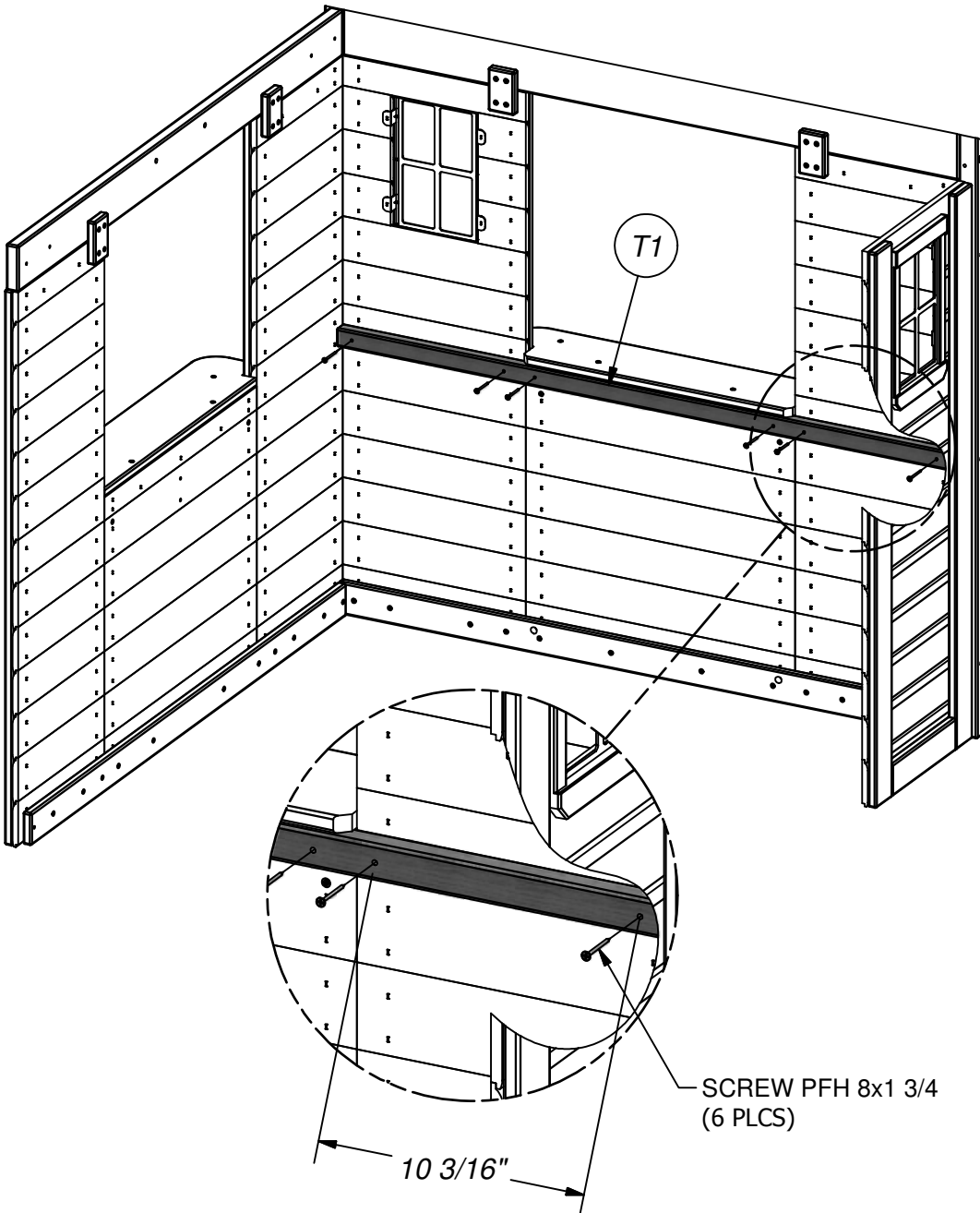

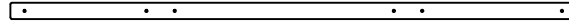

(1) **T1 - TIE STRAP - W103192**  
1"x1 3/8"x47 1/8" (24x34x1198)

**STEP 16**

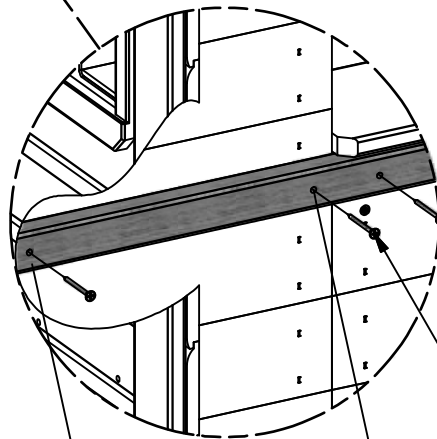
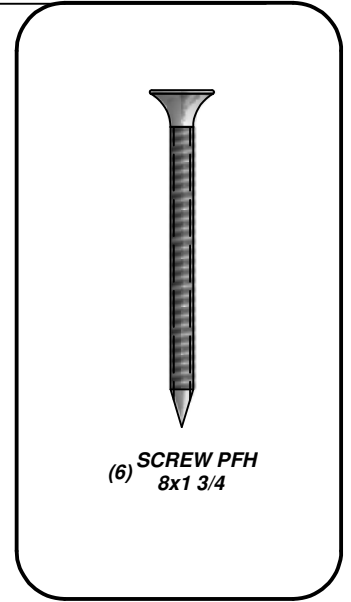
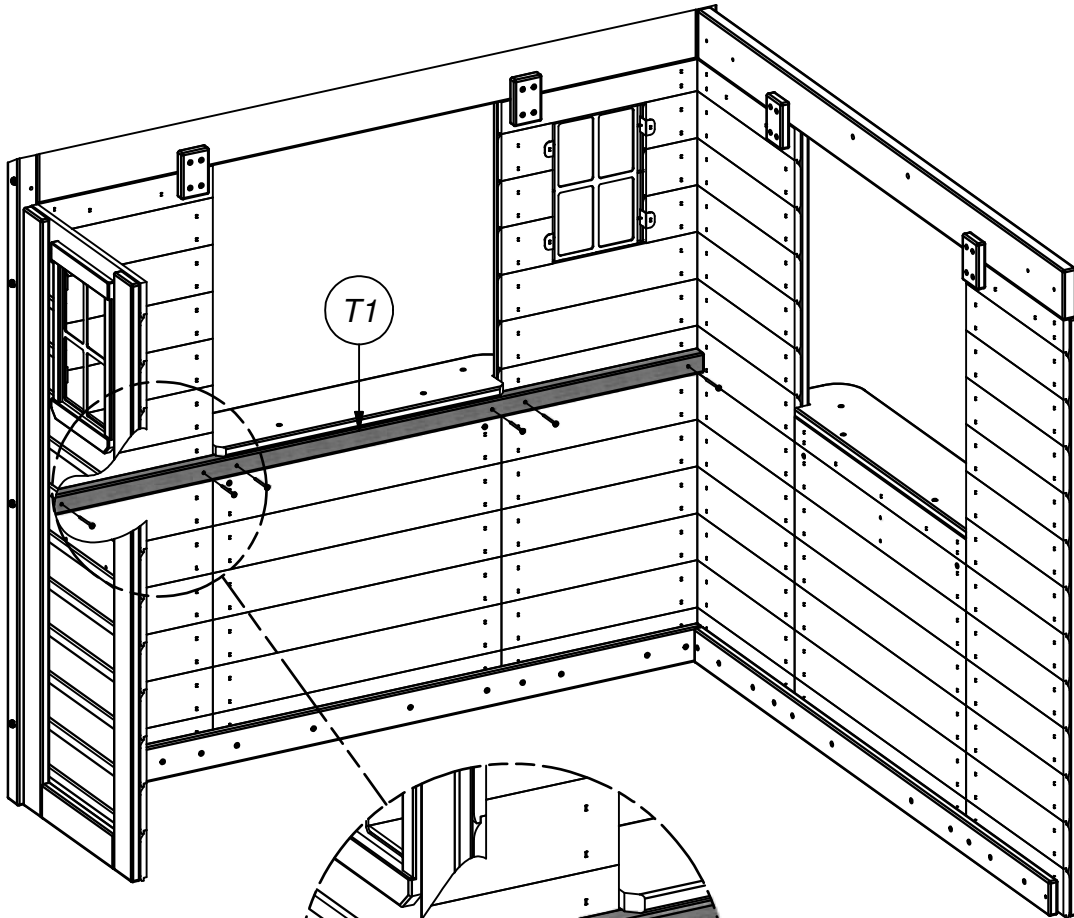

SCREW PFH 8x1 3/4  
(6 PLCS)

10 3/16"

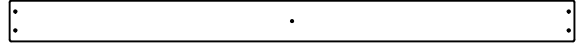

(1) **G1 - COUNTER SUPPORT - W4L05257**  
 1"x5 1/4"x6 3/4" (24x134x170)

(2) **M1 - COUNTER TOP - W4L05255**  
 5/8"x3 3/8"x47 1/8" (16x86x1196)

**STEP 17**

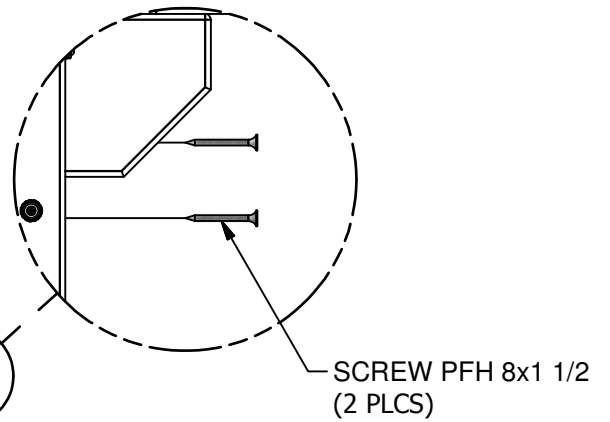
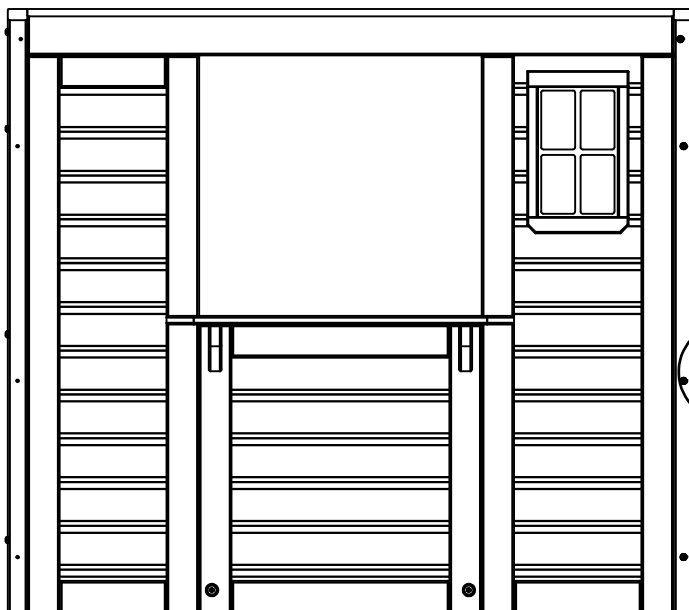
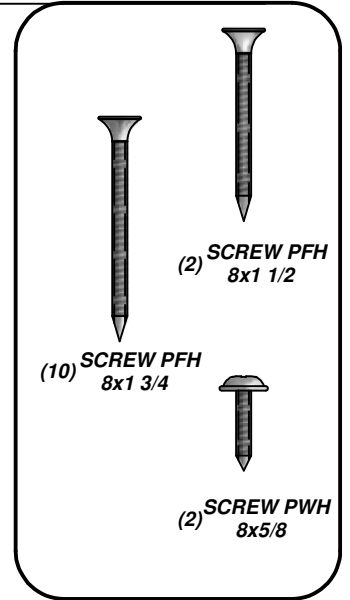
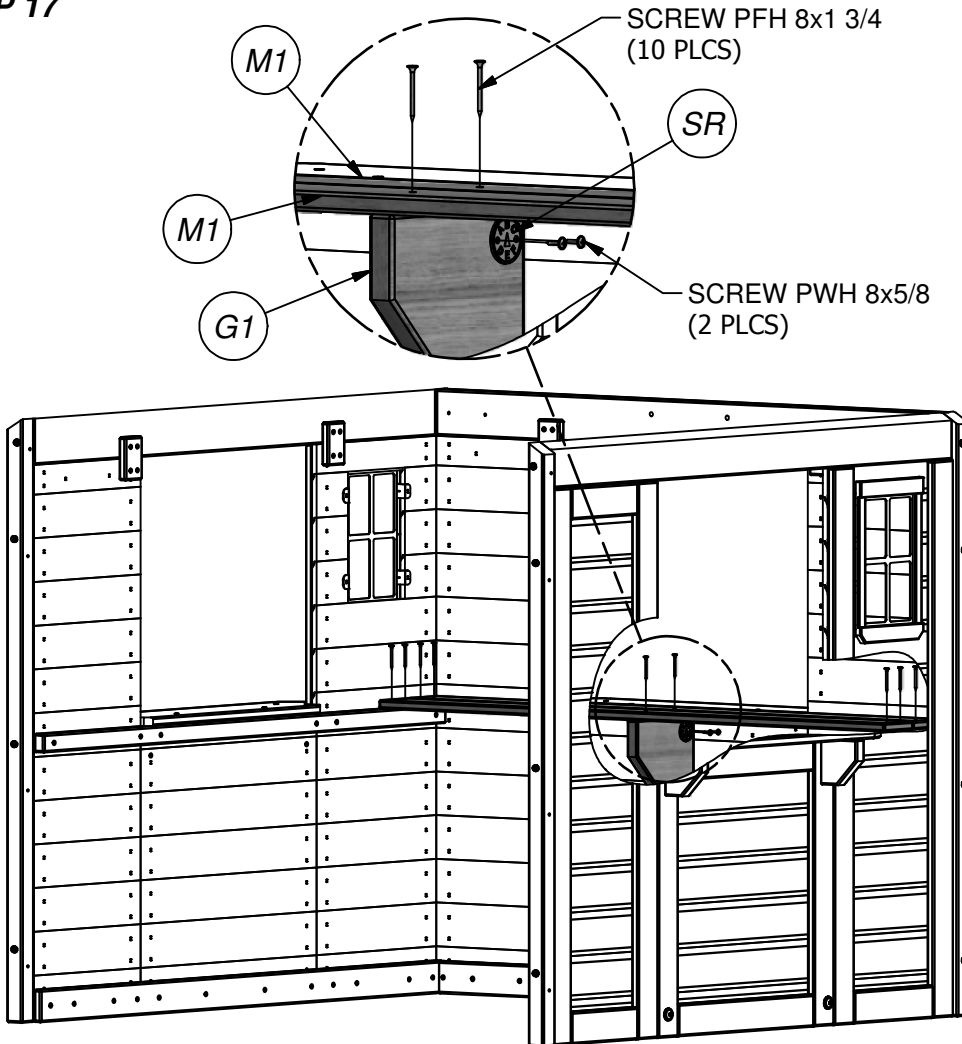



(1) - SURFACE MOUNT BASIN - A6P00032

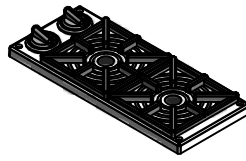

(1) - STOVE KIT - A6P00025



(1) - FAUCET KIT - A6P00024

### STEP 18

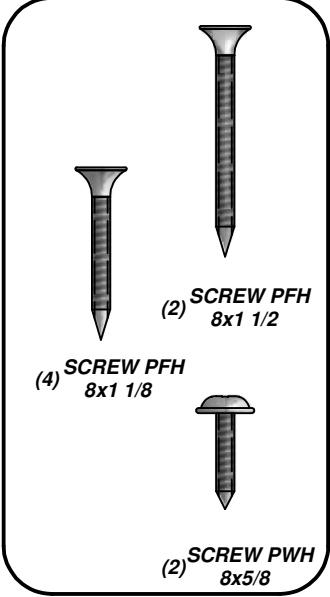
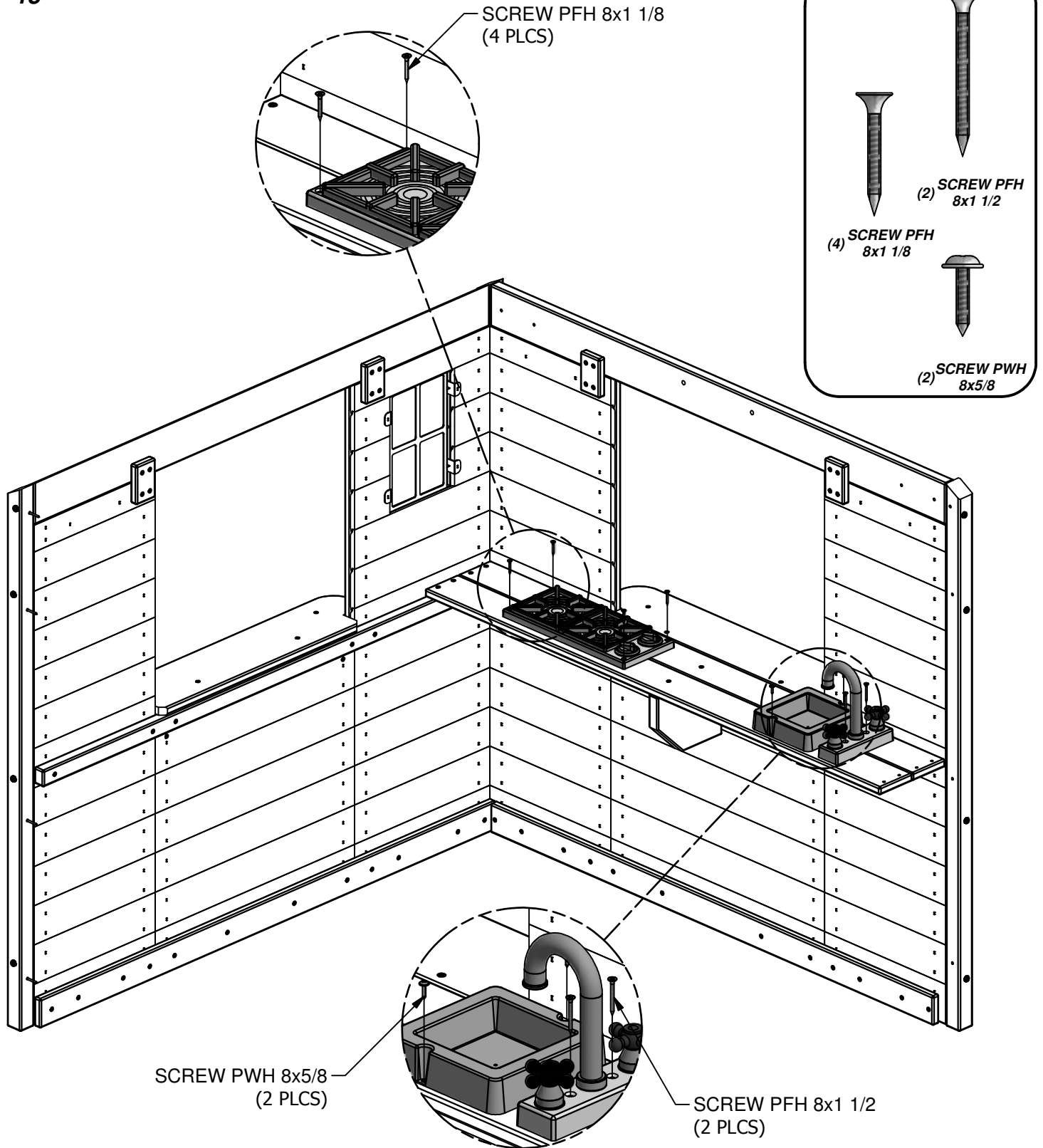

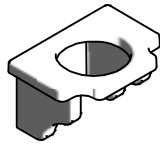

(2) - FLOWER POT HOLDER - A6P00023

**STEP 19**

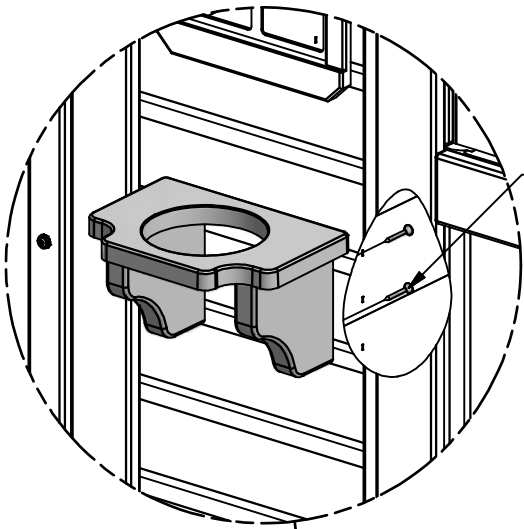

SCREW PFH 8x1 1/4  
(8 PLCS)

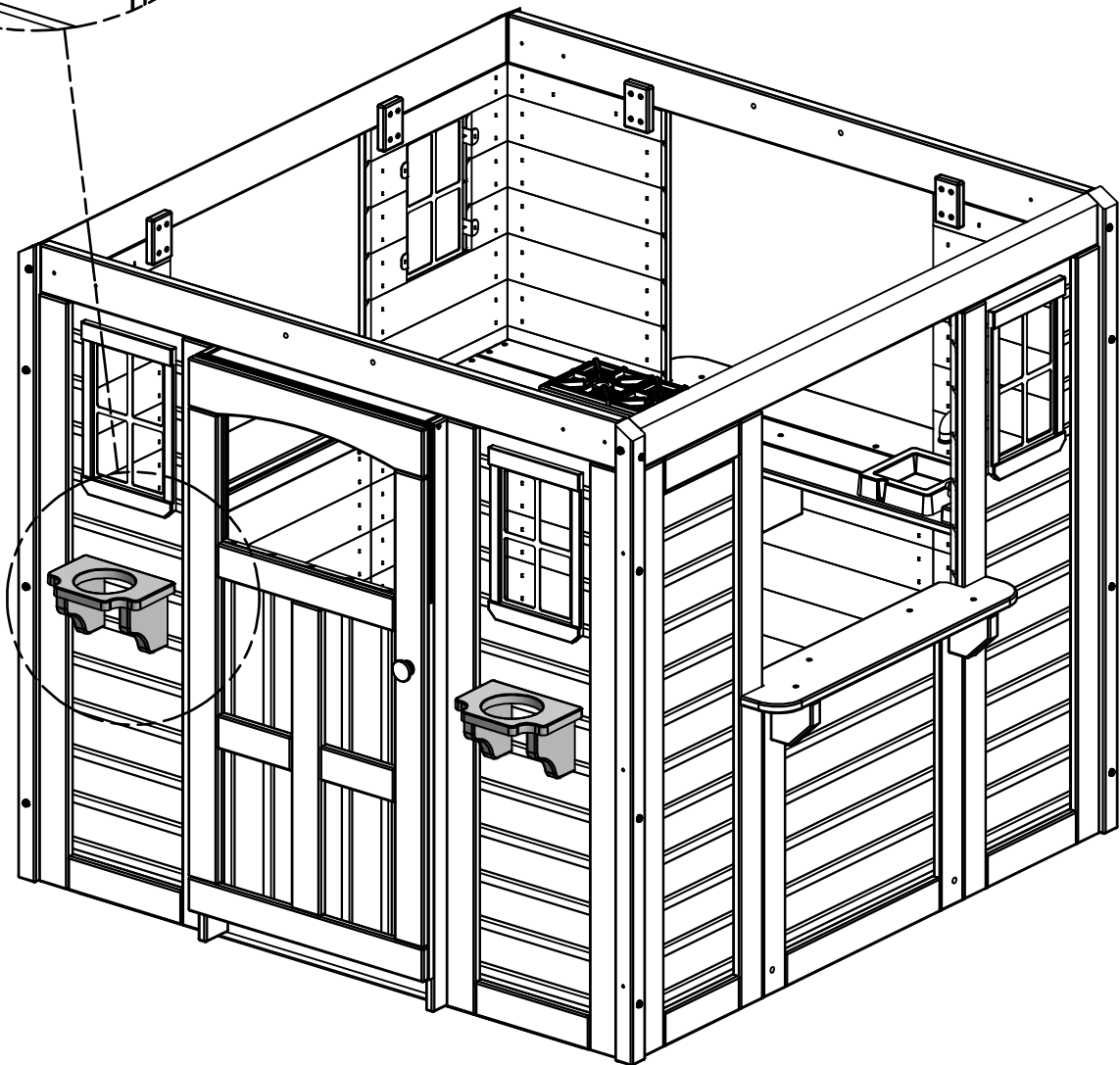
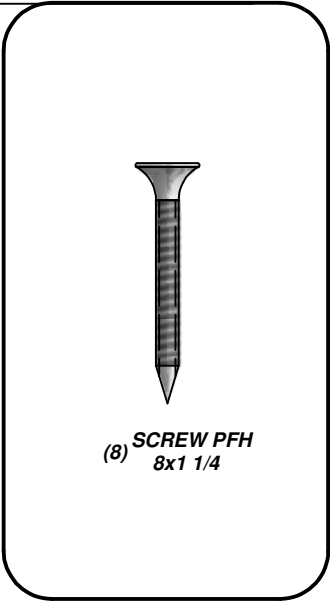

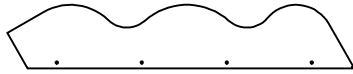

(4) **K3 - RAFTER - W103194**  
5/8"x5 1/4"x28 7/8" (16x134x735)

**STEP 20**

SCREW PFH 8x1 1/2  
(8 PLCS)

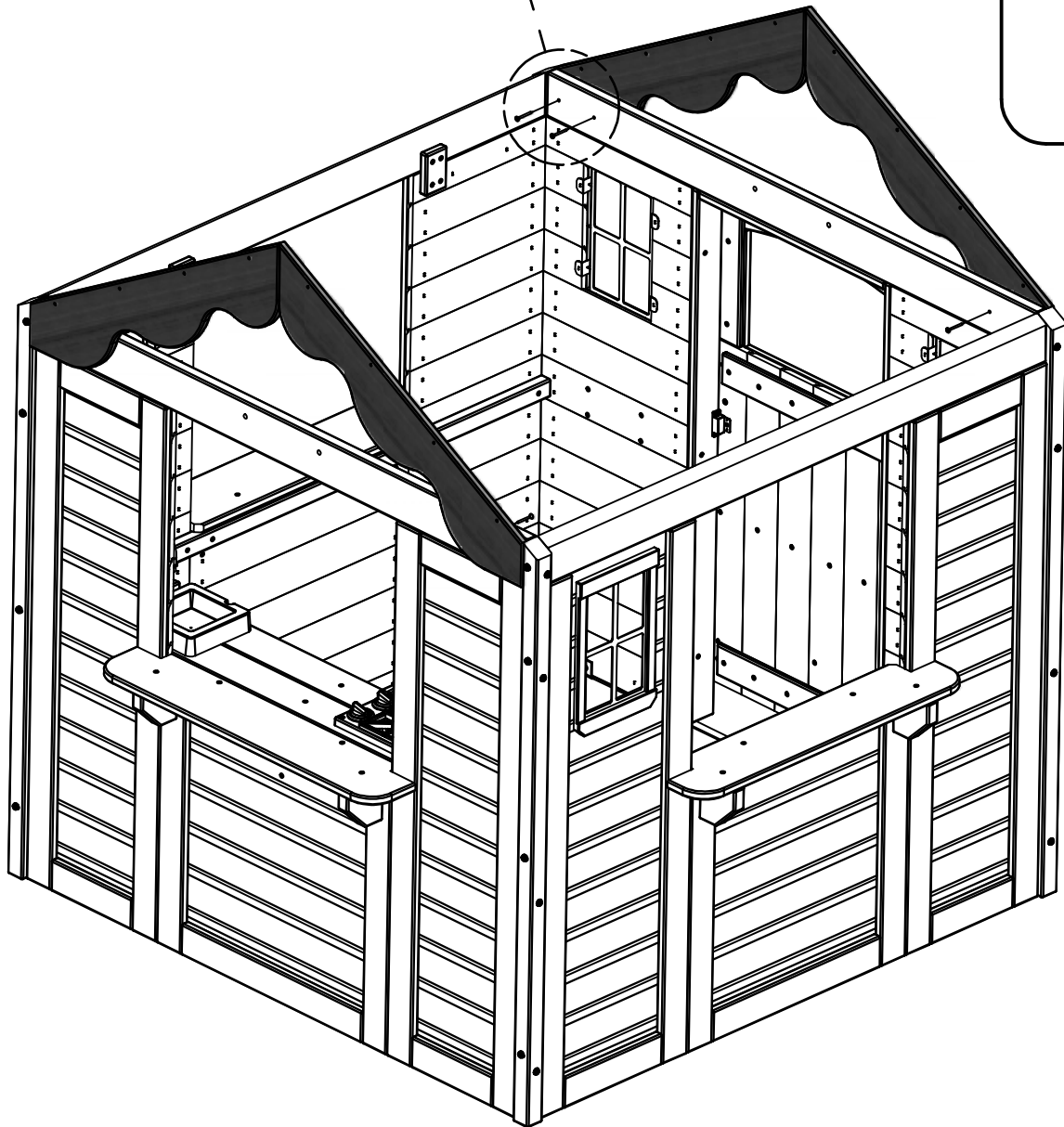
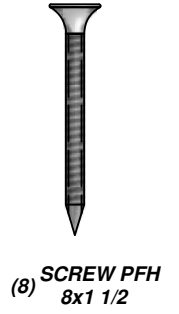
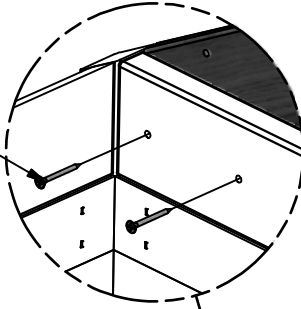

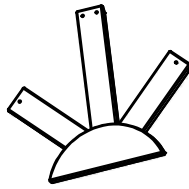

(2) VB - PLASTIC SUNBURST - A100361

**STEP 21**

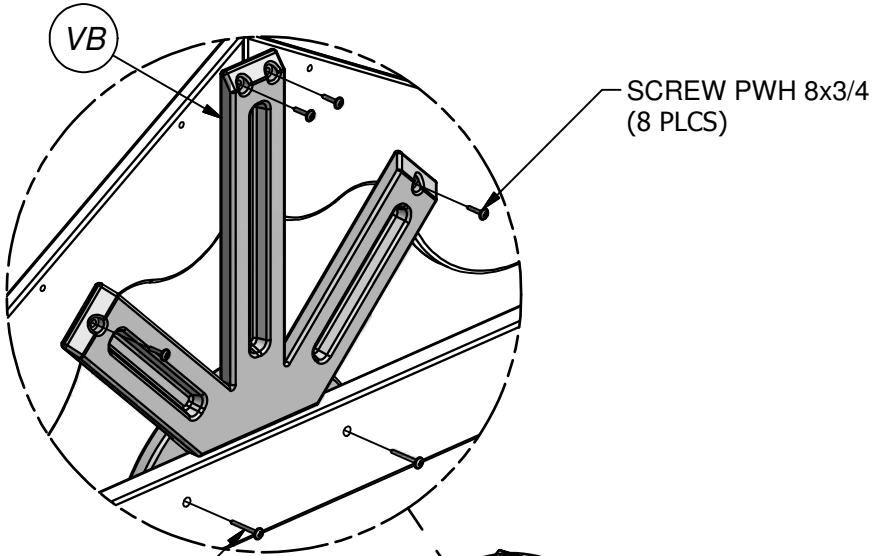

SCREW PWH 8x1-1/4  
(4 PLCS)

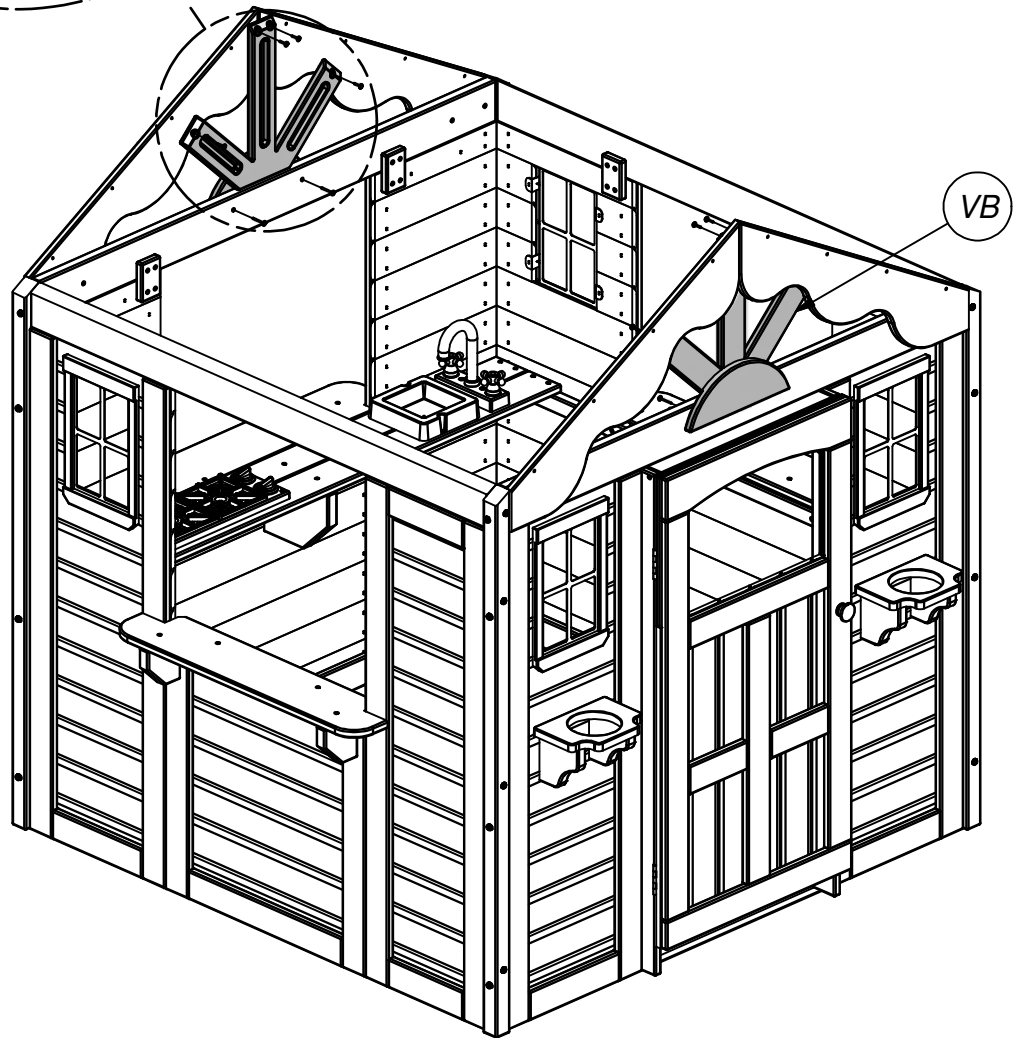
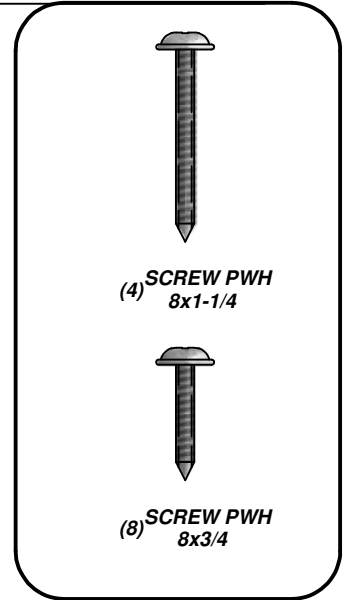

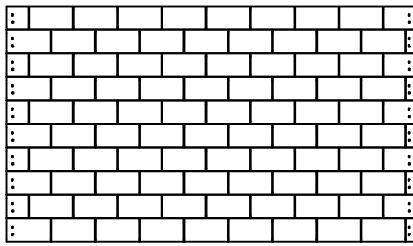

(2) RP1 - ROOF PANEL - W2A01665  
1 3/8"x31 7/8"x55 3/8" (35x809x1405)

**STEP 22**

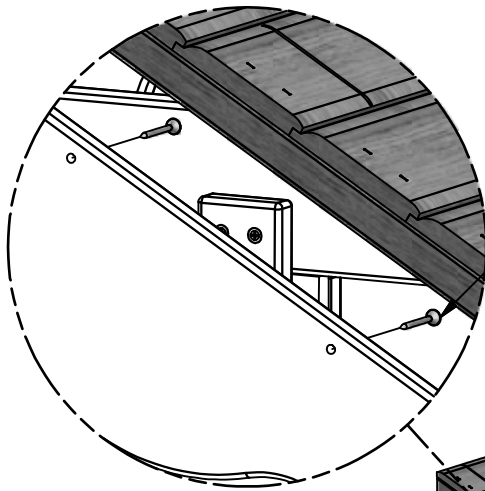

SCREW PFH 8x1 1/2  
(16 PLCS)

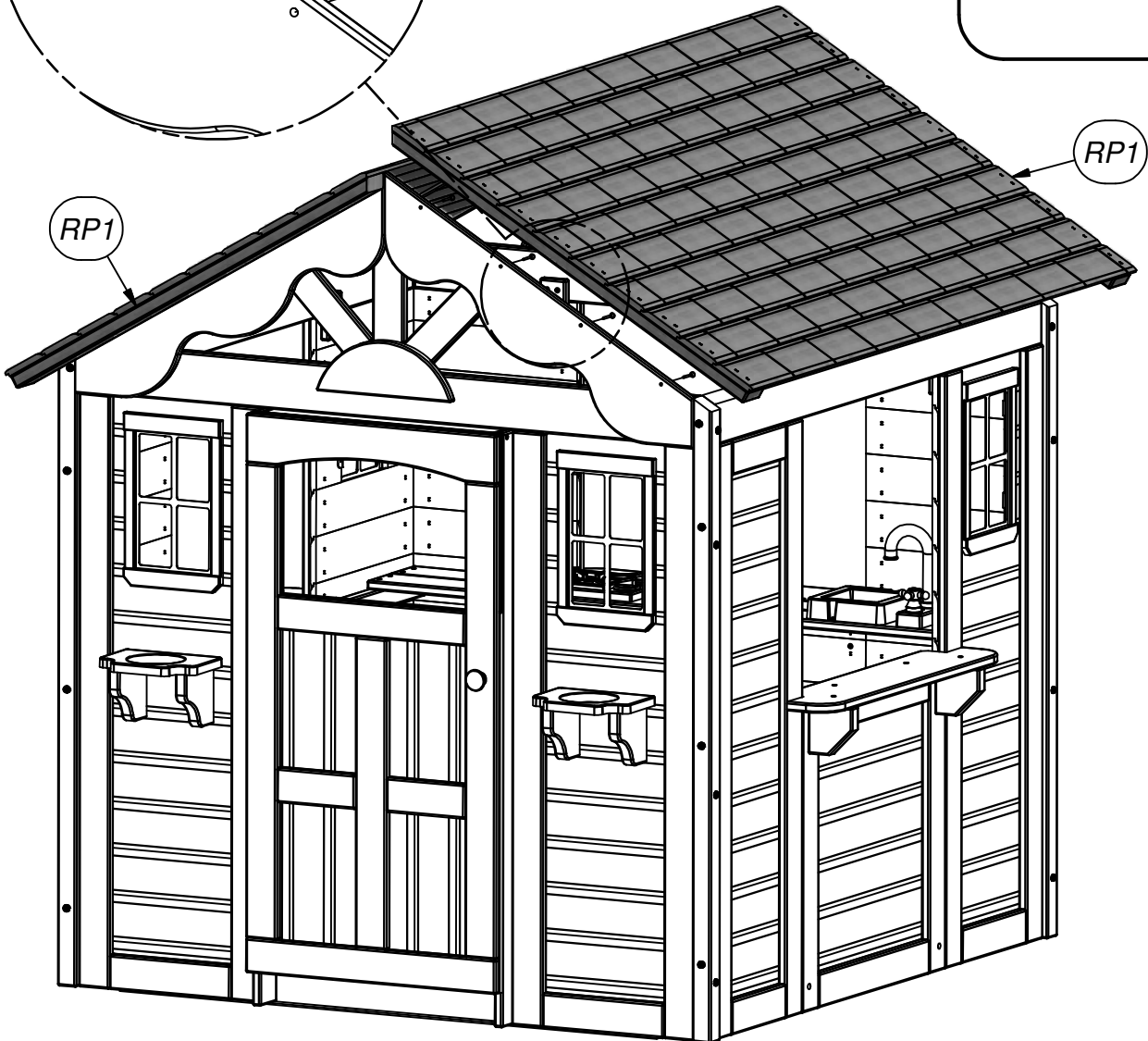
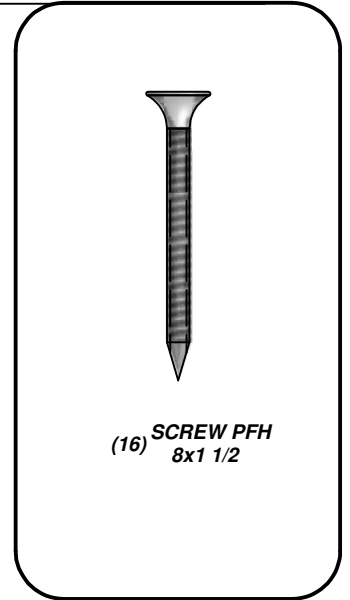



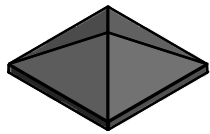

(1) *WD - CUPOLA LOUVER - A100385*

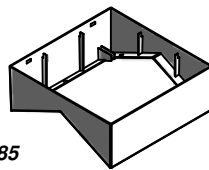
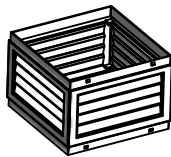

(1) *WC - CUPOLA BASE - A100384*

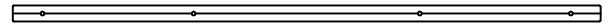

(1) *O1 - SCREW BLOCK - W103197*  
*5/8"x1 3/8"x49" (16x34x1245)*

(1) *WE - CUPOLA ROOF - A100386*

**STEP 23**

DOUBLE RIBS

SINGLE RIB RESTS BETWEEN DOUBLE RIBS SHOWN ON PREVIOUS PANEL.

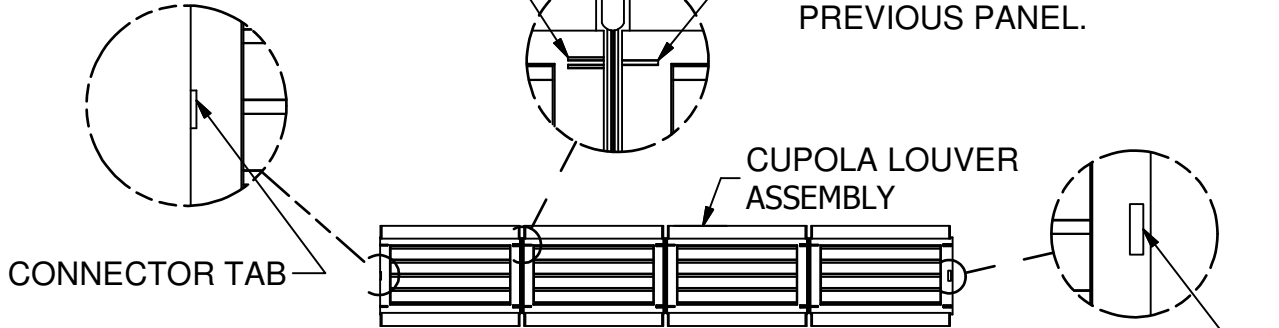

**FOLD CUPOLA LOUVER PANEL INTO SQUARE SHAPE AND LOCK INTO PLACE BY SLIDING CONNECTOR TAB INTO CONNECTOR SLOT.**

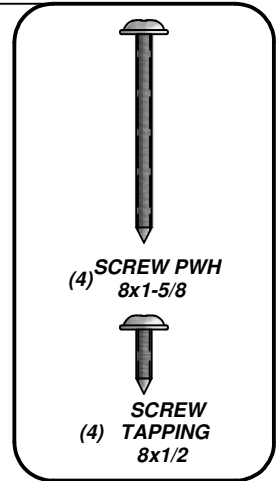

CONNECTOR SLOTS

CUPOLA ROOF

**ATTACH CUPOLA BASE TO CUPOLA LOUVERS BY SLIDING CONNECTOR TABS DOWN INTO CONNECTOR SLOTS LOCATED ON THE INSIDE WALLS OF CUPOLA BASE. NOW, ATTACH CUPOLA ROOF TO CUPOLA LOUVERS BY SLIDING CONNECTOR SLOTS OVER CONNECTOR TABS IN CUPOLA LOUVER, AS SHOWN.**

SCREW TAPPING 8x1/2  
(4 PLCS)

WE

WC

WD

WB

WB

O1

SCREW PWH 8x1-5/8  
(4 PLCS)

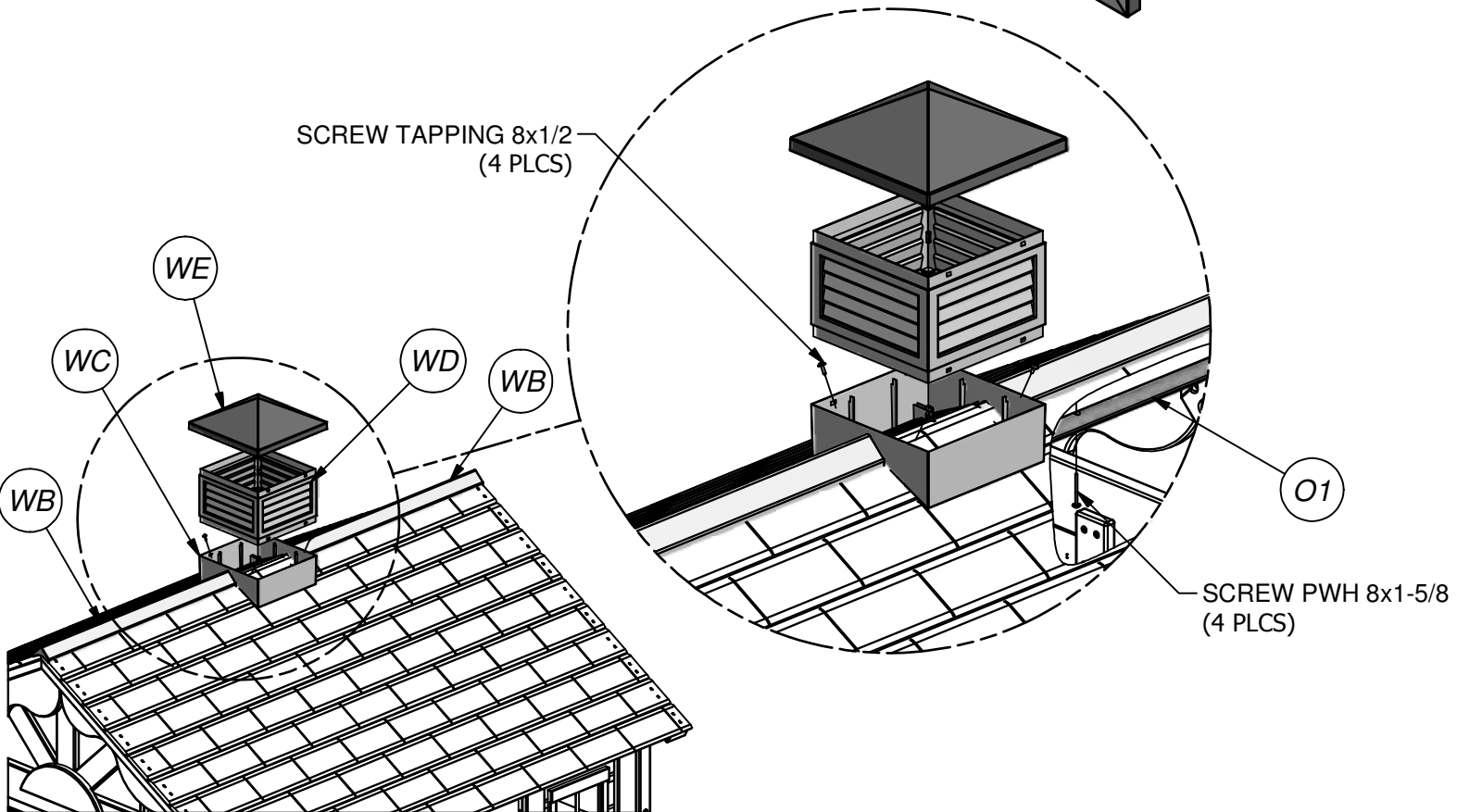

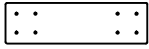

(2) **H5 - BENCH UPRIGHT - W102471**  
1"x3 3/8"x11 3/4" (24x86x300)



(2) **H6 - BENCH GROUND BOARD - W102472**  
1"x3 3/8"x18 1/8" (24x86x460)



(2) **FZ - L BRACKET WHITE 32x51 - A100133**

### STEP 24

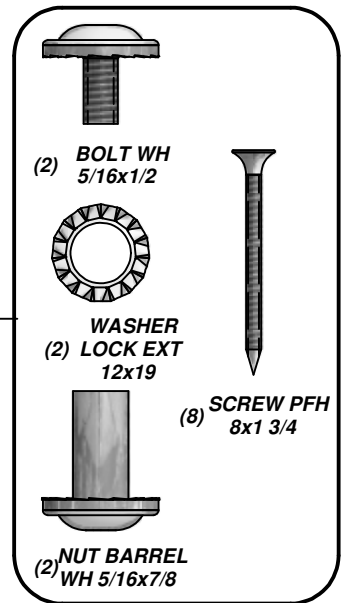
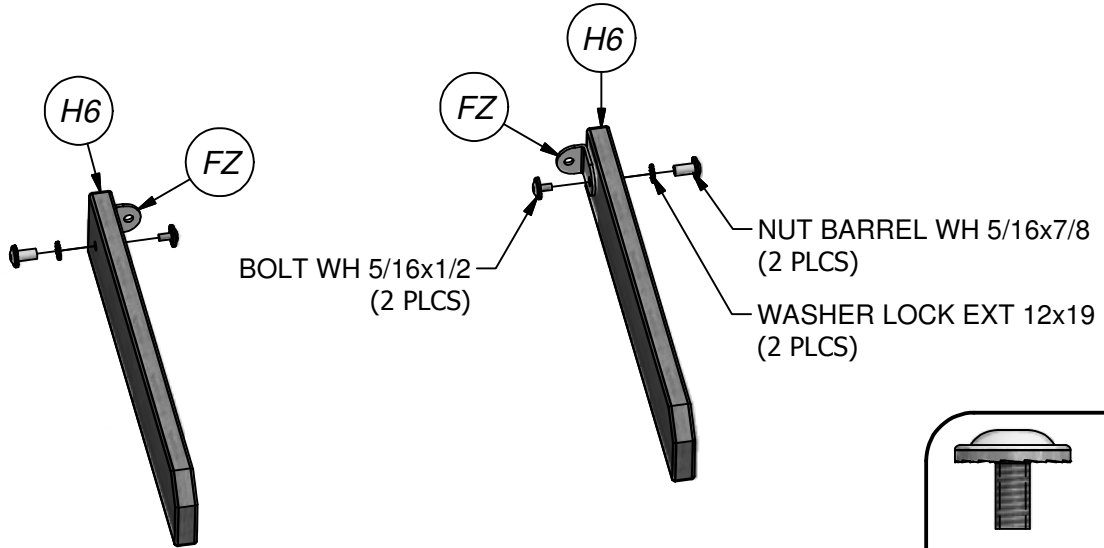

### STEP 25

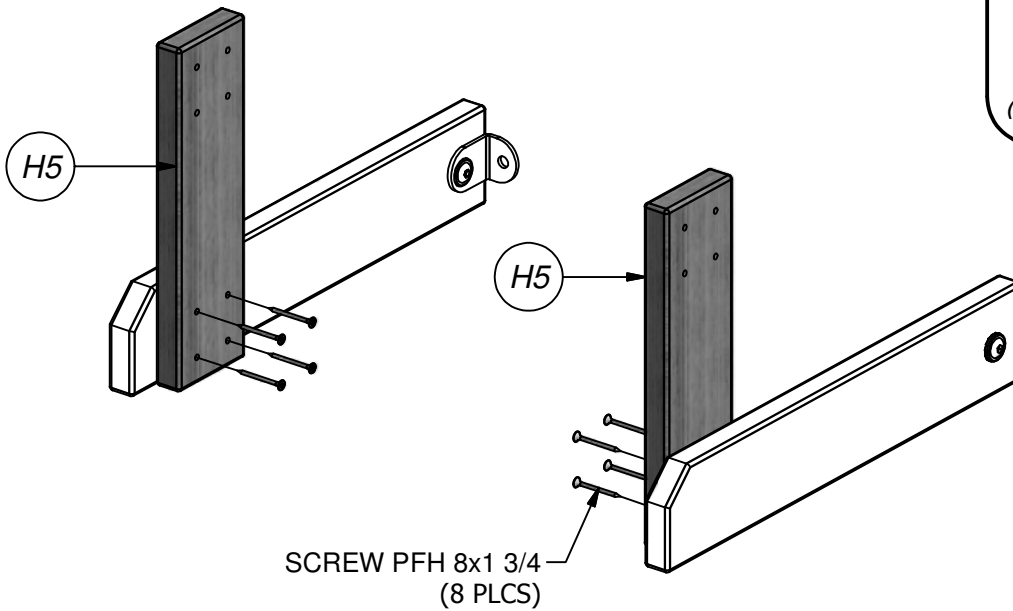



(2) **H4 - BENCH SEAT SUPPORT - W102470**  
1"x3 3/8"x6 1/2" (24x86x166)

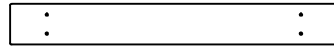

(2) **M2 - BENCH SEAT - W102469**  
5/8"x3 3/8"x27 3/8" (16x86x694)

**STEP 26**

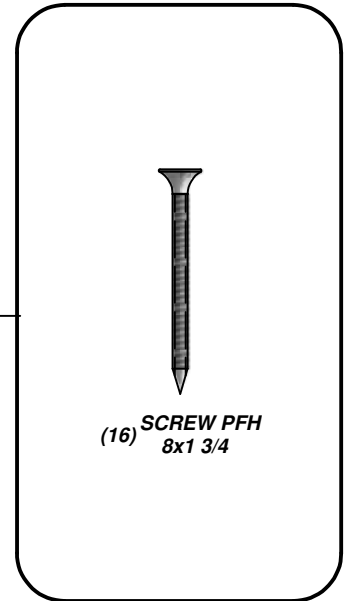
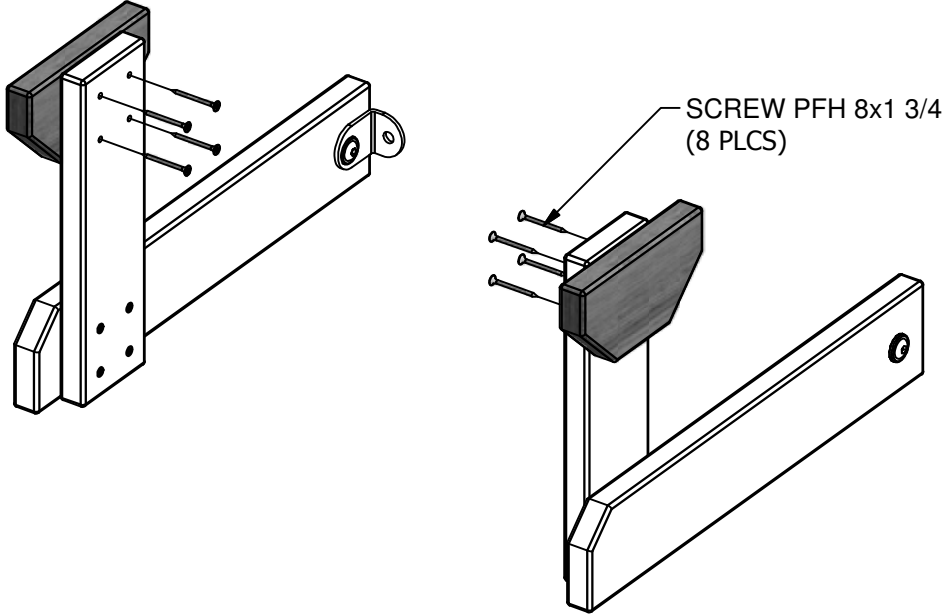

**STEP 27**

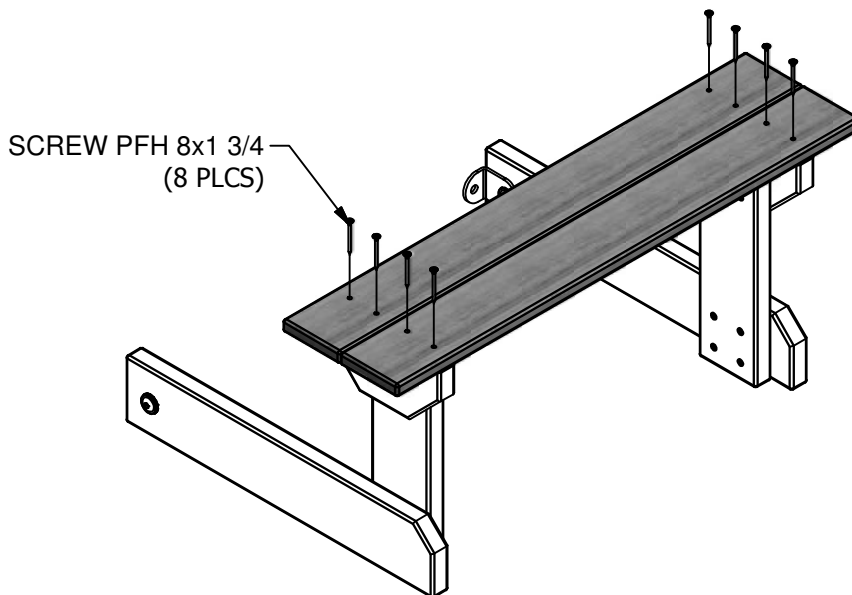

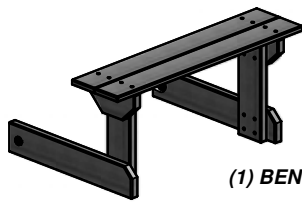

(1) BENCH ASSEMBLY

**STEP 28**

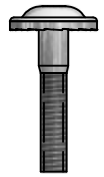
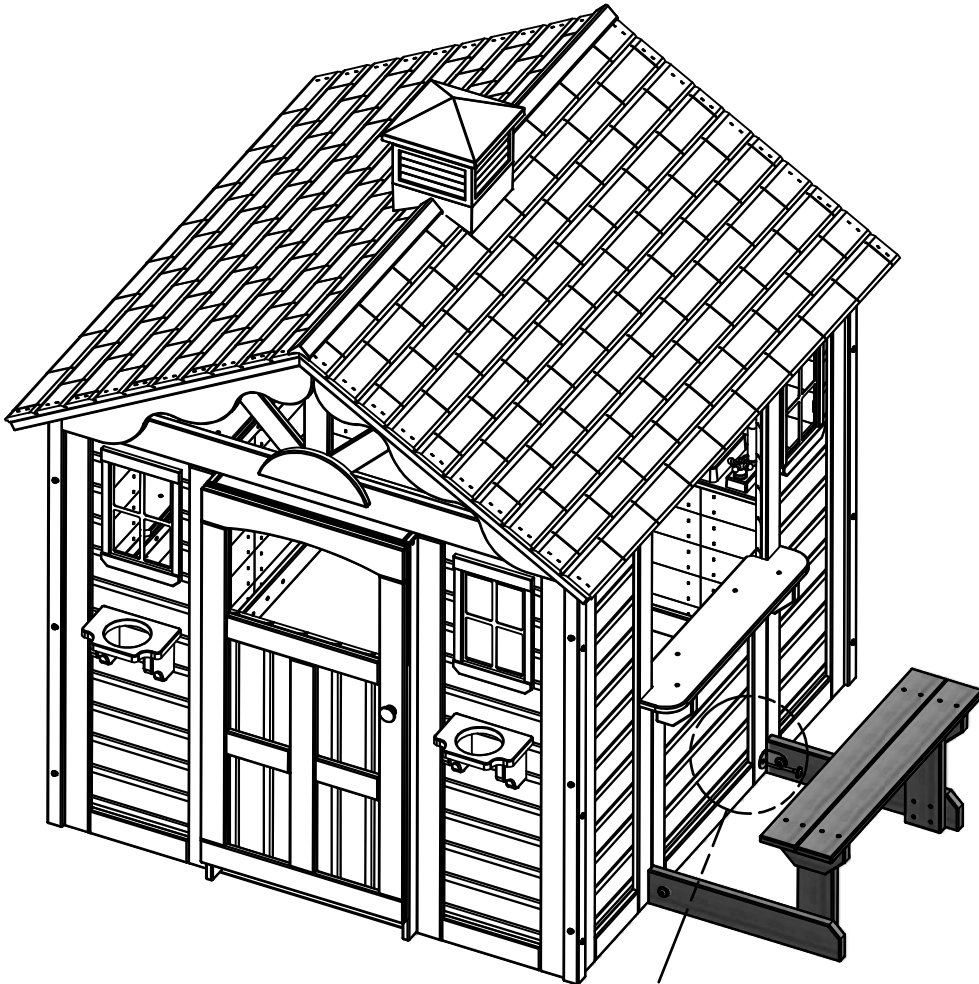

(2) BOLT WH  
5/16x1 1/2



WASHER  
(2) LOCK EXT  
12x19



NUT BARREL  
(2) WH 5/16x5/8

NUT BARREL WH 5/16x5/8  
(8 PLCS)

WASHER LOCK EXT 12x19  
(8 PLCS)

BOLT WH 5/16x1 1/2  
(8 PLCS)



(1) - LTP ID TAG (SMALL) WITH AGES - A4M00515

**STEP 29**

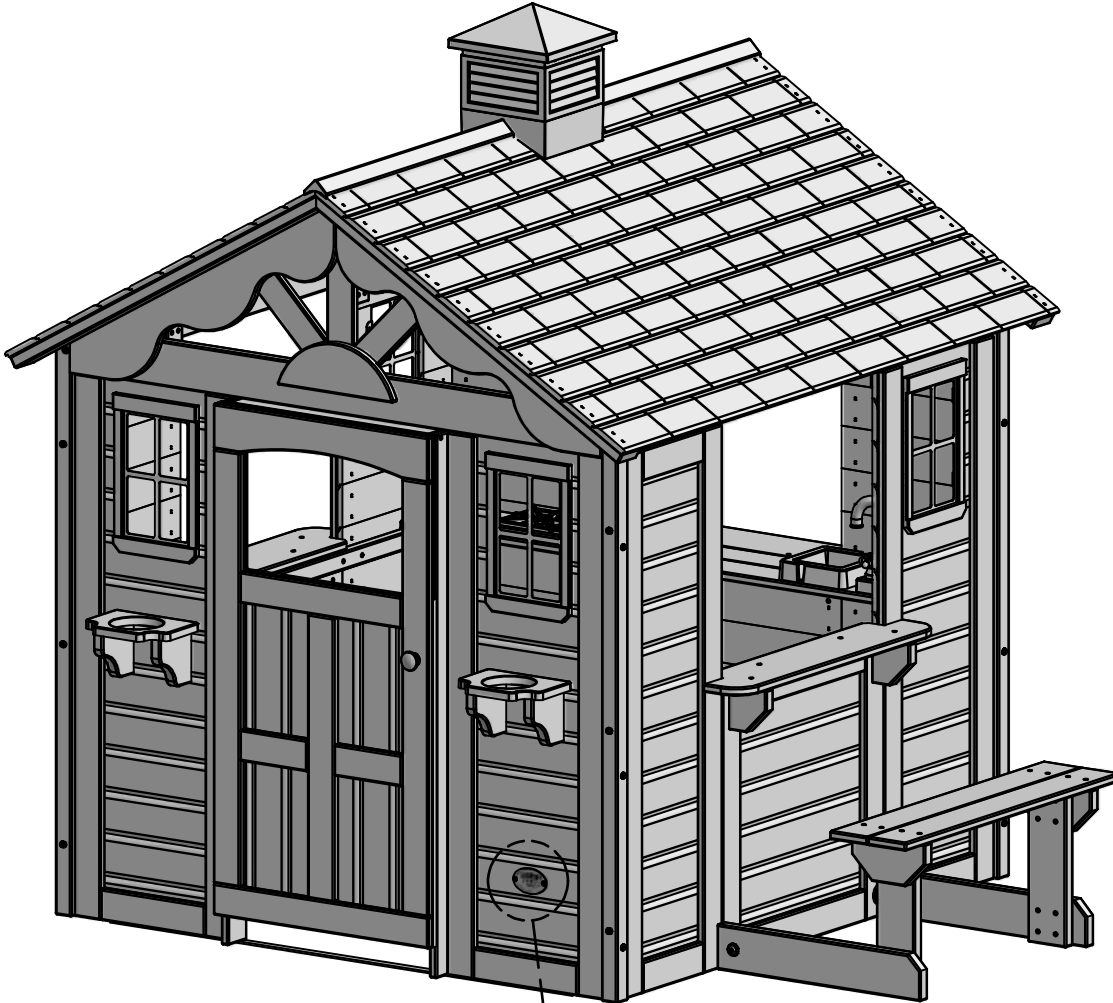

(2) SCREW PFH  
8x1/2

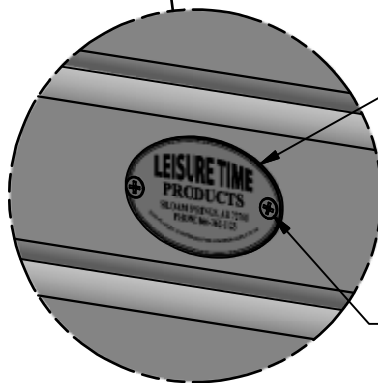

LTP ID TAG (SMALL) WITH AGES  
(1 PLC)

SCREW PFH 8x1/2  
(2 PLCS)