

Mountaineer Assembly Instructions

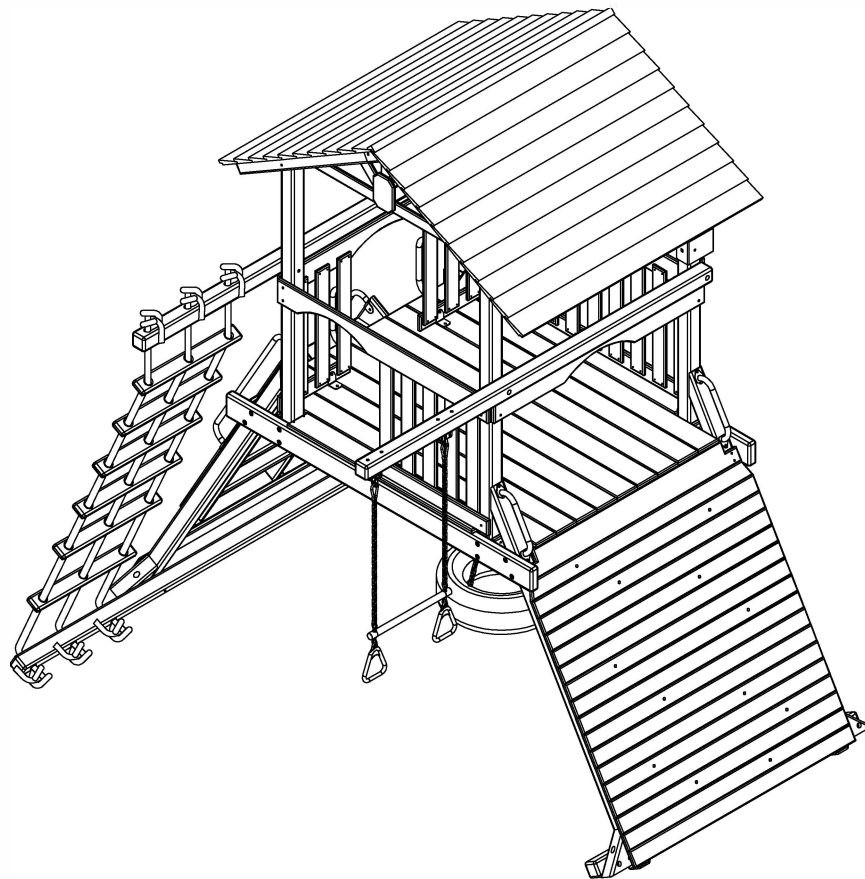

WARNING: CHOKING HAZARD

Unassembled parts may be a choking hazard to children 3 years and younger



CAUTION: Adult Assembly Required.

Hardware contains small pieces with sharp points. Keep parts out of the reach of children until assembled. Parts of this product can present dangers if improperly assembled.



CAUTION: The plastic bags that contain the hardware may present a choking hazard to small children. Please keep these bags and all plastic bags out of the reach of children. Do not allow children to play with them and dispose of them immediately when empty.

Basic Setup Dimensions

Place the set on level ground, not less than 6' [1829mm] from any structure or obstruction such as a fence, garage, house, overhanging branches, laundry lines or electrical wires.

	A	B
4 pos. SB	23'-10 1/2" [7277mm]	39'-2 3/4" [11957mm]
3 pos. SB	23'-10 1/2" [7277mm]	36'-2 3/4" [11043mm]
2 pos. SB	23'-10 1/2" [7277mm]	33'-3 3/4" [10154mm]
Monkey Bar	23'-10 1/2" [7277mm]	34'-11" [10643mm]

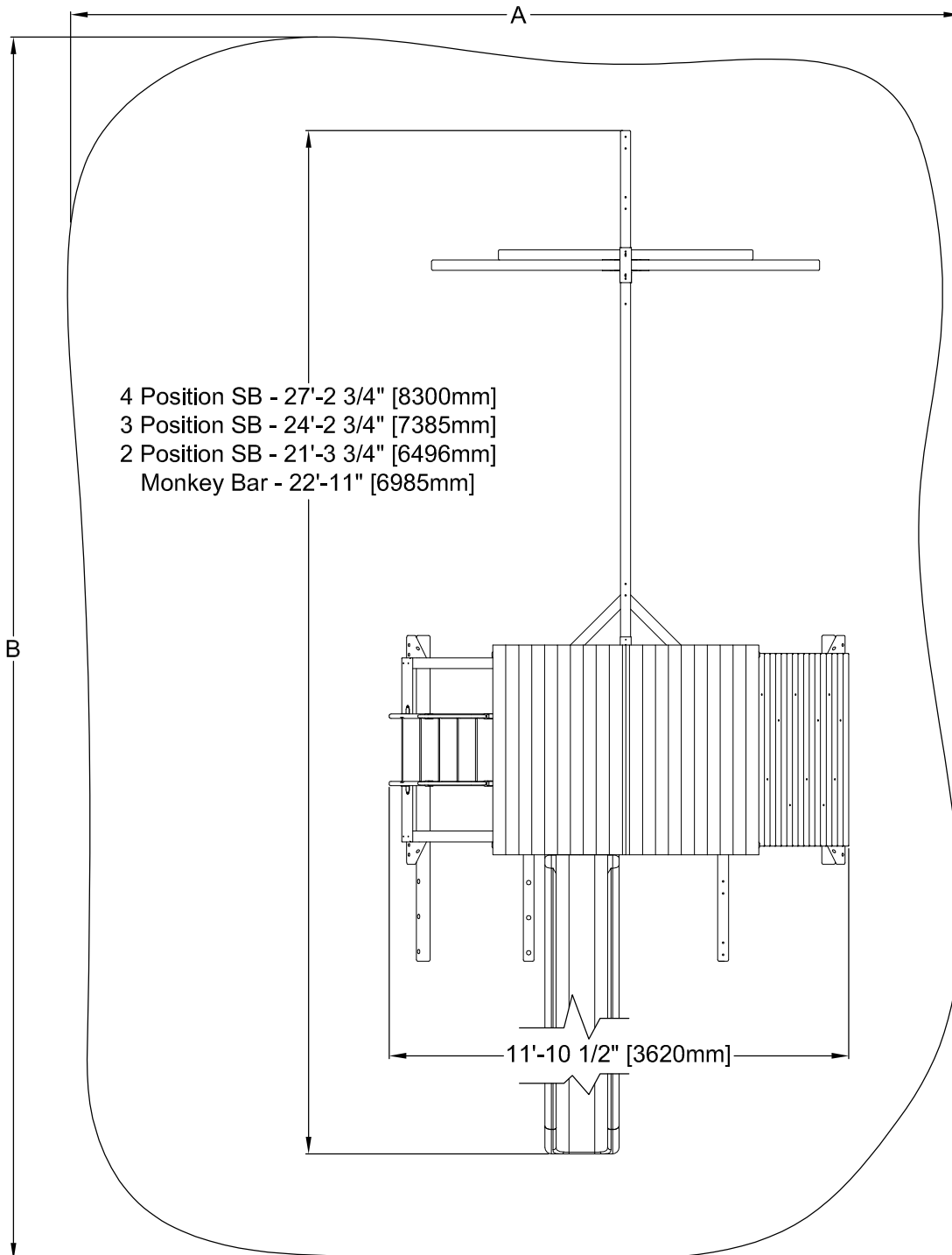

Important Assembly Notes

- Sort all lumber, metal, and accessories by ID letter prior to assembly. This will make assembly easier and faster.
- Pay close attention to make sure you are using the correct hardware in the correct places. Using incorrect hardware may result in improper assembly.
- Read the steps of each phase thoroughly. The written steps may include important information not shown in the illustrations.
- While assembling unit, take time before and after each phase to make sure Fort is level. If fort is not level, assembly will be difficult and improper assembly may result. Extra care must be taken to assure the fort is square on the phases that include this symbol in Fig i.
- When installing a board on the small face of a 2x4 or on a 4x4, pre-drilling the attachment hole is **REQUIRED**. Just place the board where attachment is needed and by using the holes in the board as a guide, drill holes into the 2x4 with a 1/8" drill bit 1 1/4" deep. Failure to Pre-drill may result in board splitting.

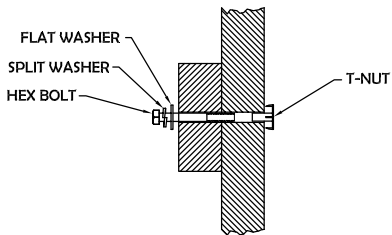
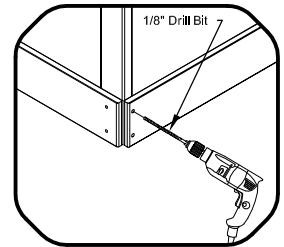
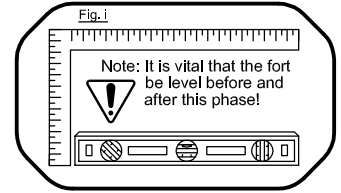

- Whenever a T-nut is used, follow these directions. Place t-nut in pre-drilled hole. Tap in with hammer. Place bolt with washers in the opposite side. Hand tighten to make sure the bolt is in the t-nut. Secure with socket. **DO NOT** over-tighten.



Be sure and not over tighten hex bolts. Bolts should not protrude more than 2 threads on opposite side.



It is highly recommended that you have at least one adult helper assisting you during installation.

Tools Required

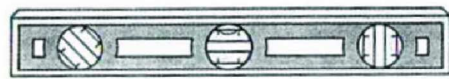

(Level 24")



(Open end Wrenches 1/2" & 9/16")



(Nut drivers 1/2" & 9/16")



(Tape Measure)



(3/8" Ratchet, 1/2" & 9/16" STD sockets 1/2" & 9/16 deep sockets)



(Claw Hammer)

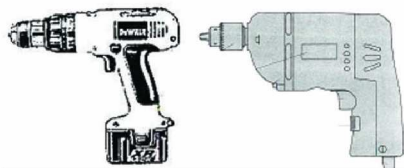

(3/8" Cordless Drill or Electric drill)
****USE OF IMPACT DRILL NOT RECOMMENDED****



(3/16", 5/16" & 3/8" drill bits)



(Drill attachments: Phillips head screw 3/8" Socket Driver Torque head screw)

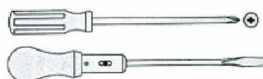

(Phillips & Straight Blade Screwdrivers)











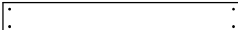



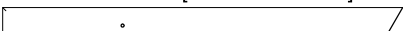
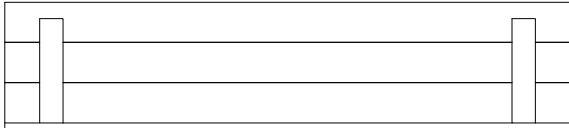
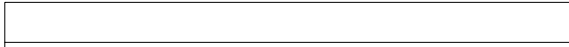
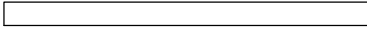

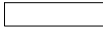
(Rubber Mallet -Optional)

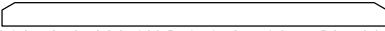
Parts Identification Wood Components

ID	DESCRIPTION	QTY
A	4L3073-11 - 4x4x066 3/4 [102x102x1695mm] Fort Upright (w/o cross brace hole) 	2
B	4L3083-11 - 4x4x066 3/4 [102x102x1695mm] Fort Upright (w/ cross brace hole) 	2
C	4L3088-11 - 4x6x083 [102x152x2108mm] Floor Support (Rip to 2x5 3/8" [51x137mm]) 	2
D	4L2168-07 - 5/4x6x057 [32x152x1448mm] Side Arched Wall Rail 	1
E	4L3071-11 - 5/4x6x057 [32x152x1448mm] Wall Rail 	7
F	4L3072-11 - 5/4x6x057 [32x152x1448mm] Center Arched Wall Rail 	2
G	4L3070-11 - 4x4x101 [102x102x2565mm] Rope Ladder Ground Beam 	1
H	4L3081-11 - 4x4x071 [102x102x1803mm] Ground Beam 	1
I	4L3087-11 - 4x4x080 5/16 [102x102x2040mm] Angled Fort Leg 	4
J	4L1866-06 - 4x6x009 15/16 [102x152x252mm] Angle Support Brace 	4
K	4L3082-11 - 5/4x6x057 [32x152x1448mm] Floor Brace 	1
L	4L3060-11 - 5/4x6x050 [32x152x1270mm] End Floor Board 	2
M	2A1325-11 - 5/4x6x074 [32x152x1880mm] Floor Panel Assembly (3 board) 	3
N	4L3076-11 - 5/4x4x019 [32x102x483mm] Wall Rail 	2
O	4L1573-06 - 5/4x4x030 1/4 [32x102x768mm] Wall Rail 	1
P	4L1574-06 - 5/4x4x057 [32x102x1448mm] Wall Rail 	2
Q	2A1323-11 - Rockwall Panel Assembly (4 board) 	1
R	2A1324-11 - Rockwall Panel Assembly (6 board) 	2
S	4L3079-11 - 5/4x4x059 3/4 [32x102x1518mm] Rockwall Board 	1
T	4L3089-11 - 5/4x6x057 [32x152x1448mm] Rockwall Board 	1

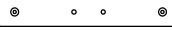
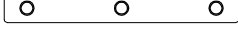

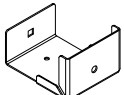







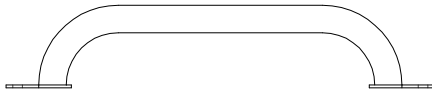
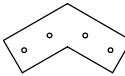
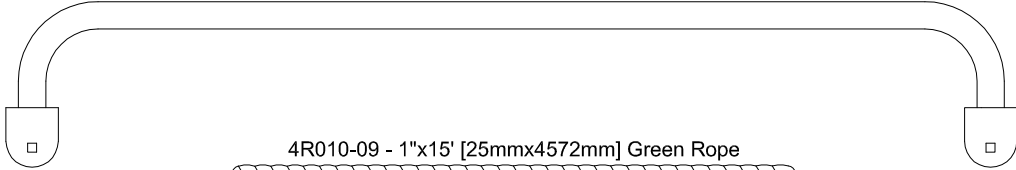

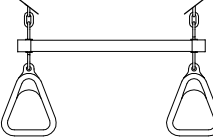
Parts Identification Wood/Hardware Components

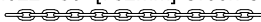
ID	DESCRIPTION	QTY
U	4L3077-11 - 5/4x4x062 [32x102x1575mm] Rockwall Brace 	1
V	4L1424-05 - 1x4x027 1/4 [25x102x692mm] Wall Slat 	20
W	4L3074-11 - 4x4x094 [102x102x2388mm] Rope Ladder Accessory Arm 	1
X	4L3075-11 - 4x4x094 [102x102x2388mm] Trapeze Accessory Arm 	1
**Y	4L2915-10 - 4x6x057 [102x152x1448mm] Cross Brace 	1
Z	4L3078-11 - 2x4x046 [51x102x1168mm] Roof Truss 	4
AA	2A1095-06A - 65" [1651mm] Roof Panel Assembly (3 board) 	6
AB	4L1924-06 - 5/4x6x065 [32x152x1651mm] Roof Board 	2
AC	4L2118-09 - 1x3x042 [25x76x1067mm] Roof Brace 	2
AD	4L2866-09 - 2x4x005 1/2 [51x102x140mm] Roof Swedge 	2
AE	4L1337-04 - 2x2x065 [51x51x1651mm] Roof Ridge Cap 	1
AF	4L004 - 1x3x012 [25x76x305mm] Sunburst Vertical Spoke 	2
AG	4L200-06 - 1x6x008 [25x152x203mm] Sunburst Center Piece w/Logo 	2
AH	4L3085-11 - 1x3x009 1/4 [25x76x235mm] Sunburst Spoke 	4
AI	4L3086-11 - 1x3x044 1/4 [25x76x1124mm] Sunburst Horizontal Rail 	2
AJ	4L614 - 2x6x020 1/4 [51x152x514mm] Ladder Rung 	5
AK	4L740-05 - 2x6x062 [51x152x1575mm] Ladder Rail (Left) 	1
AL	4L741-05 - 2x6x062 [51x152x1575mm] Ladder Rail (Right) 	1
AN	4L1516-05 - 4x4x021 [102x102x533mm] Tire Swing Mounting Block 	1
AO	4L583 - 2x4x027 [51x102x686mm] Rope Ladder Rung 	6
AP	4M1122-11 - 2x82" [51x2083mm] Metal Strip 	2
AQ	4M032 - L-bracket (Green) 	11
**AR	4M1114-10 - Cross Brace Clamp 	2

**These parts are found in the single beam hardware box.

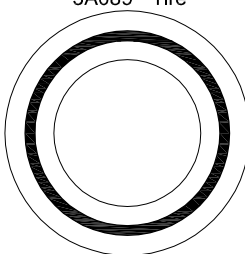
NOTE: All widths and heights shown are nominal sizes, not actual sizes. Lengths are shown in actual size.

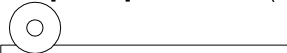
Parts Identification Hardware Components

ID	DESCRIPTION	QTY
AS	4M1028-10 - Grab Handle (Green) 	4
AT	4M1123-11 - Mending Plate 	2
AU	4M1005-08 - 4' [1219mm] Handrail (Green) 	2
AV	4R010-09 - 1"x15' [25mmx4572mm] Green Rope 	3
AW	1TZG36-08 - 36" [914mm] Green Trapeze 	1
AX	6HASH - Large Swing Hanger 	2
AY	4M022 - 30" [762mm] Green Chain 	3
AZ	6H079 - Clevis Link 	3
BA	6HTRS - Tire Swivel 	1
BB	6H076 - Tire Eye Bolt 	3
BC	3A089 - Tire 	1
BD	6PCR6 - Assorted Climbing Rocks (bag of 6) 	2
BE	6BP02 - BYA Placard 	1
BF	6M012 - 16" [406mm] Rebar Stakes (bag of 6) 	1
BG	6HSL - Snap Link 	3

NOTE: All widths and heights shown are nominal sizes, not actual sizes. Lengths are shown in actual size.

Parts Identification

Hardware

5/16" x 6 1/2" [8mmx165mm] Hex Bolts

6HHB61/2

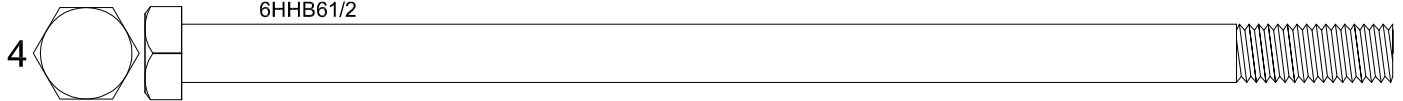

5/16" x 6" [8mmx152mm] Hex Bolts

6HHB6

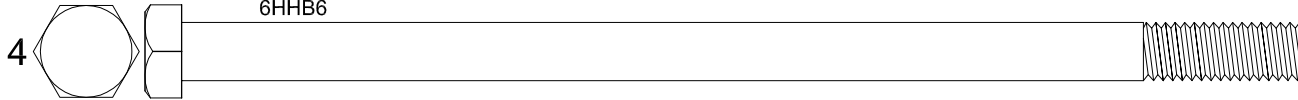

5/16" x 5" [8mmx127mm] Hex Bolts

6HHB5



5/16" x 4 1/2" [8mmx114mm] Hex Bolts

6HHB4 1/2



5/16" x 4" [8mmx102mm] Hex Bolts

6HHB4

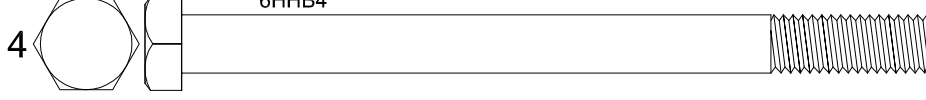

5/16" x 1 1/2" [8mmx38mm] Hex Bolts

6HHB1 1/2

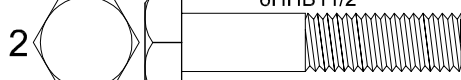

5/16" x 1 1/4" [8mmx32mm] Hex Bolts

6HHB1 1/4

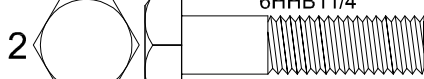

5/16" [8mm] Anti-turn Washers

6H033

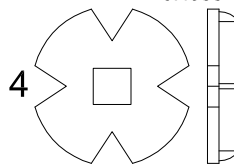

#8 x 1" [25mm] Deck Screws

6HS1



#8 x 1 1/4" [32mm] Deck Screws

6HS1 1/4

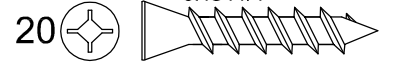

#8 x 1 1/2" [38mm] Deck Screws

6HS1 1/2

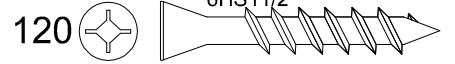

#8 x 1 3/4" [44mm] Deck Screws

6HS1 3/4



#8 x 2 1/4" [57mm] Deck Screws

6HS2 1/4

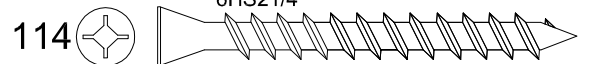

Measuring hardware

It is very important that you get the right hardware in the correct place when assembling the unit.

NOTES:

- 1) Do not include bolt head when measuring length of bolt.
- 2) Include full length of deck screw when measuring.

1/4" [6mm] T-Nuts

6H020

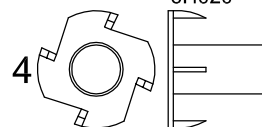

1/4" [6mm] Split Washers

6H017

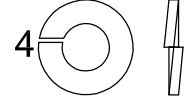

1/4" [6mm] Flat Washers

6HFW1/4

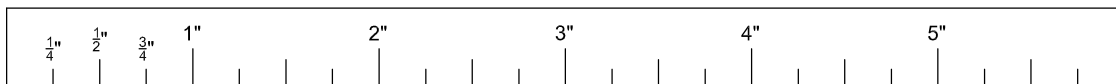
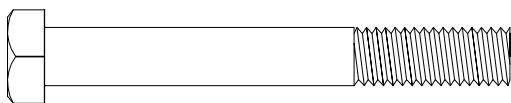
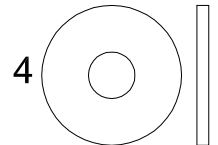

NOTE: Lengths of bolts and screws may vary slightly.

Parts Identification

Hardware

5/16" x 5" [8mmx127mm] Carriage Bolts

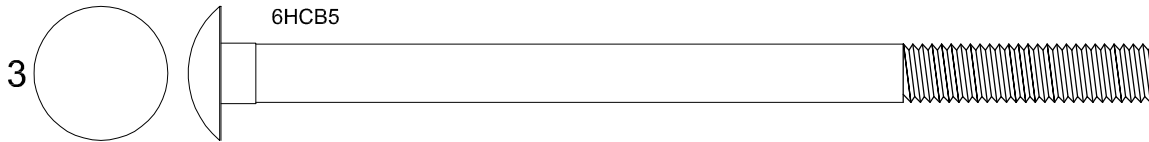

5/16" x 4" [8mmx102mm] Carriage Bolts

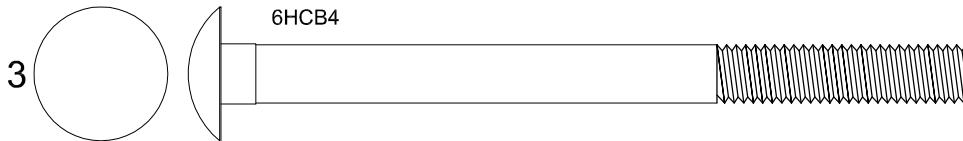

5/16" x 2" [8mmx51mm] Carriage Bolts

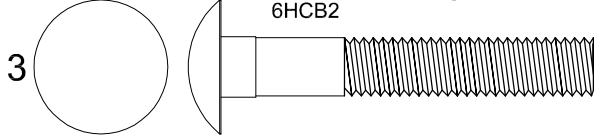

#14 x 3/4" [19mm] Tapping Screw

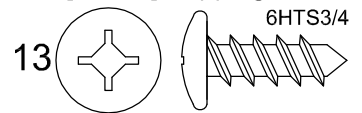

5/16" x 4 1/2" [8mmx114mm] Lag Screws

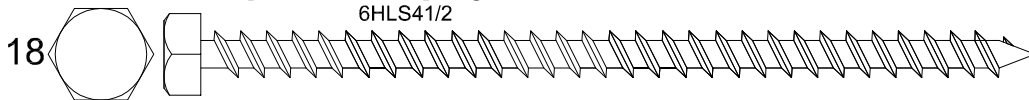

#14 x 1" [25mm] Tapping Screw

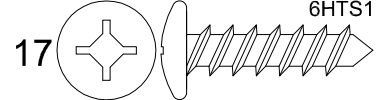

5/16" x 2" [8mmx51mm] Lag Screws

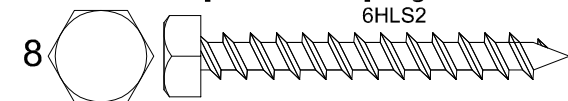

#14 x 2 1/2" [64mm] Tapping Screw

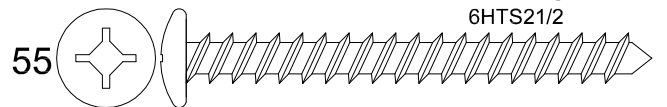

5/16" x 1 1/2" [8mmx38mm] Lag Screws

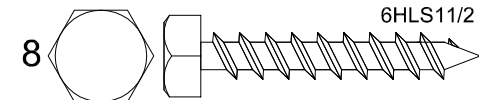

5/16" [8mm] Fender Washers

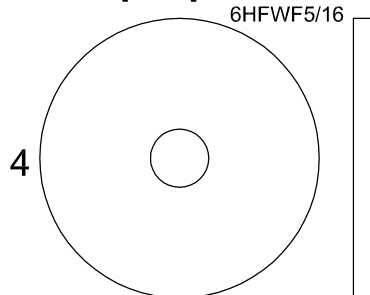

5/16" [8mm] Flat Washers

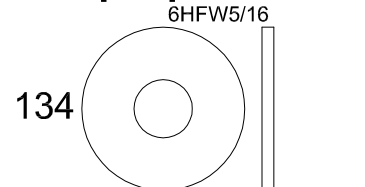

5/16" [8mm] Lock Nuts

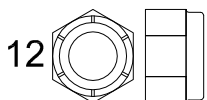

5/16" [8mm] Acorn Nuts

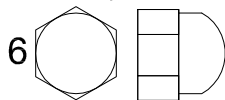

Measuring hardware

It is very important that you get the right hardware in the correct place when assembling the unit.

NOTES:

- 1) Do not include bolt head when measuring length of bolt.
- 2) Include full length of deck screw when measuring.

5/16" [8mm] T-Nuts

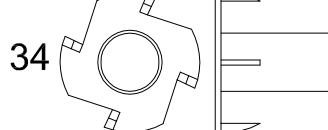

5/16" [8mm] Split Washers

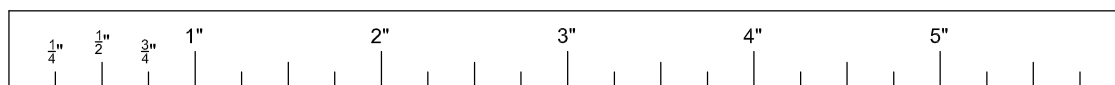
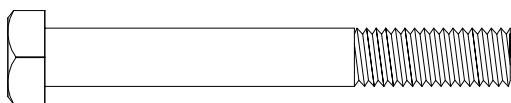

NOTE: Lengths of bolts and screws may vary slightly.

Phase 1 Frame Assembly

Items Used in this Phase

- (2) 'A' - 4x4x066 3/4 Fort Uprights
- (2) 'B' - 4x4x066 3/4 Fort Uprights
- (2) 'C' - 4x6x083 Floor Joists
- (1) 'D' - 5/4x6x057 Side Arched Wall Rail
- (5) 'E' - 5/4x6x057 Wall Rails

Step 1: Gather items A(2), B(2), C(2), D(1), E(5) and hardware bag.

Step 2: *Assembly 1:* Fasten floor joist C to uprights A using (2) 5" hex bolts, (2) 5/16" flat washers, (2) 5/16" split washers, and 5/16" t-nuts each upright (Fig. 2). Attach arched wall rail D to uprights A using (2) 4 1/2" hex bolts, (4) 5/16" flat washers, (2) 5/16" split washers, (2) 5/16" t-nuts, and (2) 2 1/2" tapping screws (Fig. 1).

Step 3: *Assembly 2:* Fasten floor joist C to uprights B using (2) 5" hex bolts, (2) 5/16" flat washers, (2) 5/16" split washers, and 5/16" t-nuts each upright (Fig. 2). Attach wall rail E to uprights A using (2) 4 1/2" hex bolts, (4) 5/16" flat washers, (2) 5/16" split washers, (2) 5/16" t-nuts, and (2) 2 1/2" tapping screws (Fig. 1).

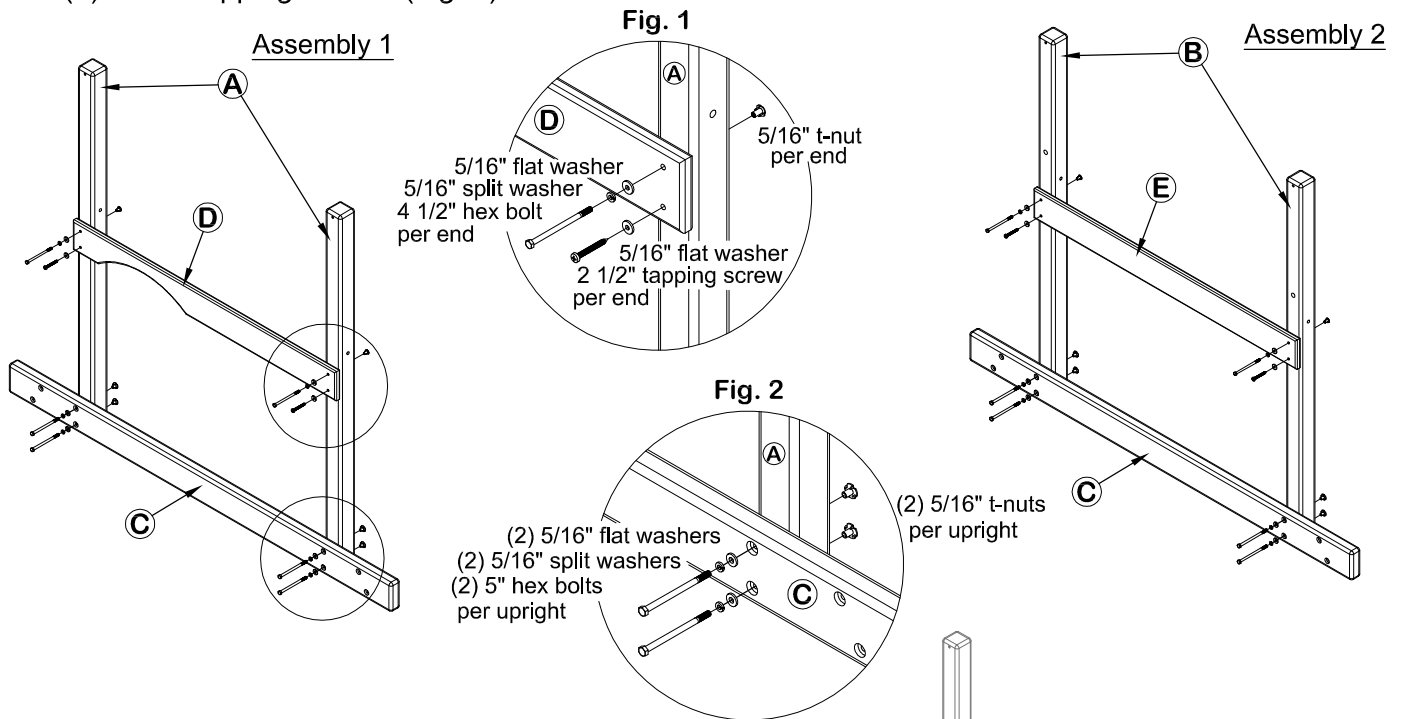

Step 4: Fasten wall rails E to inside and outside of bottom of uprights A and B using (4) 2 1/2" tapping screws and (4) 5/16" flat washers each. Make sure the tops of E are flush with the top of floor joists C before attaching.

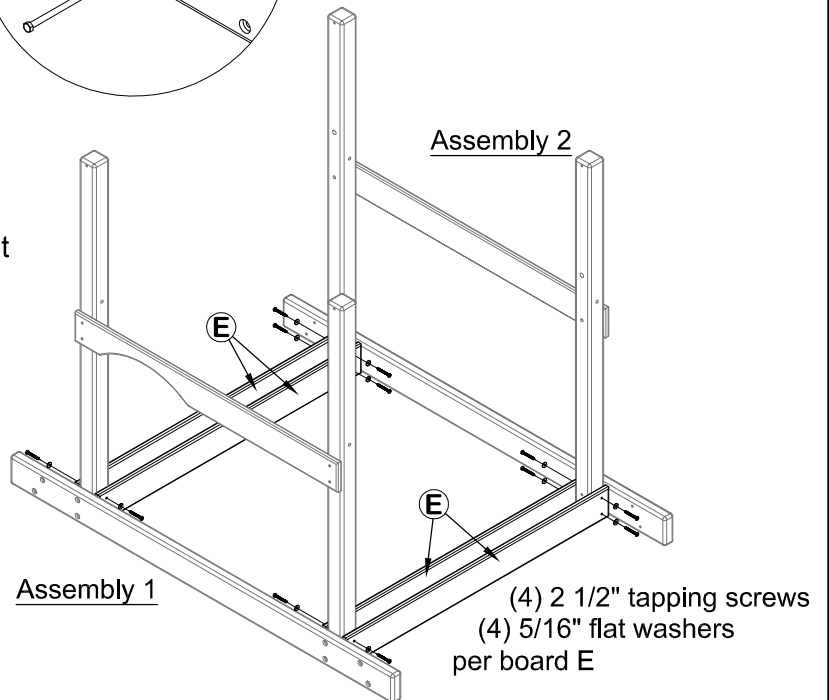

 Be sure and make note of the direction Assemblies 1 and 2 are facing.

Phase 2 Leg Assembly

- Items Used in this Phase**
- (2) 'F' - 5/4x6x057 Center Arched Wall Rails
 - (1) 'G' - 4x4x101 Rope Ladder Ground Beam
 - (1) 'H' - 4x4x071 Base Support
 - (4) 'I' - 4x4x080 5/16 Angled Fort Legs

Step 1: Gather items F(2), G(1), H(1), I(4) and hardware bag.

Step 2: Attach arched walls rails F to uprights A and B flush with the top of wall rails D and E using (4) 2 1/2" tapping screws and (4) 5/16" flat washers each (Fig. 3).

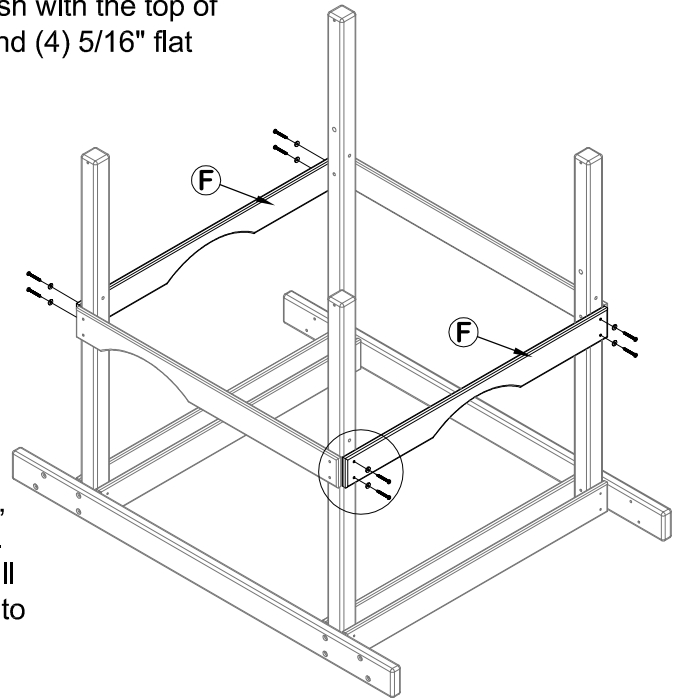
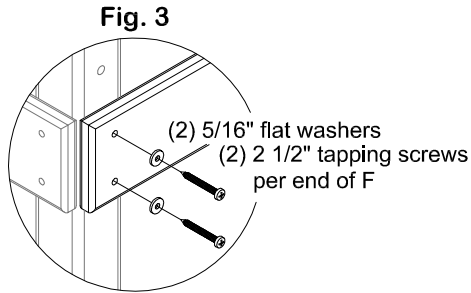

Step 3: Assembly 3: Attach angled legs I to rope ladder ground beam G using 6" hex bolt, 5/16" flat washer, 5/16" split washer, and 5/16" t-nut each leg (Fig. 4). Do not tighten bolts completely at this point, they will be tightened in the next phase. Pay close attention to the direction ground beam G is facing in relation to angled legs I.

Step 4: Assembly 4: Attach angled legs I to base support H using 6" hex bolt, 5/16" flat washer, 5/16" split washer, and 5/16" t-nut each leg (Fig. 4). Do not tighten bolts completely at this point, they will be tightened in the next phase.

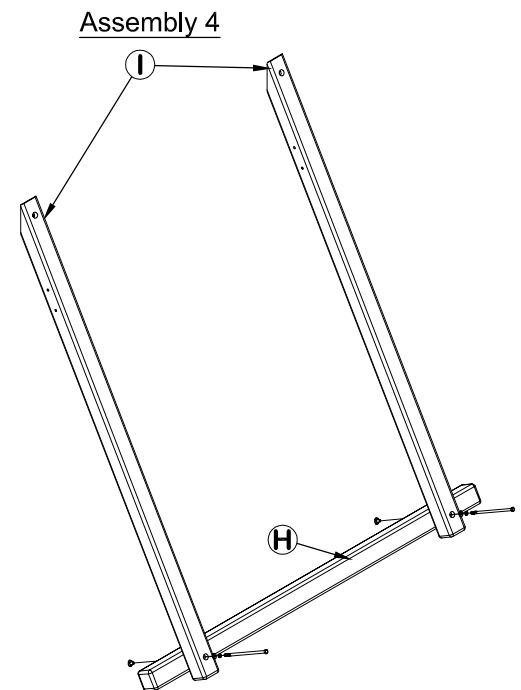
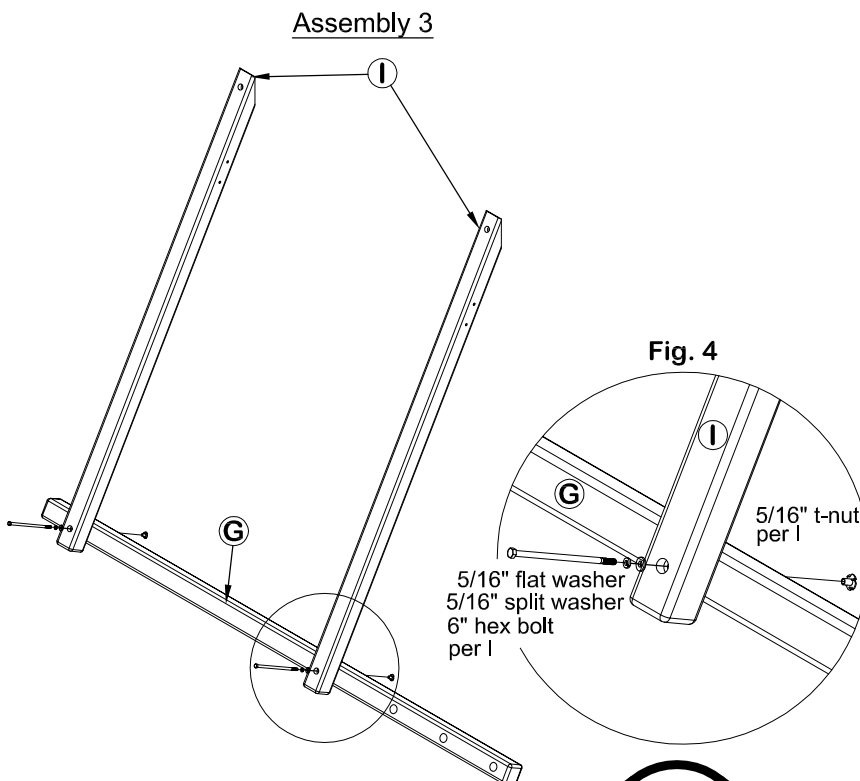

Phase 3 Leg Attachment

Items Used in this Phase
Assemblies 3 & 4 from Phase 2

Step 1: Gather Assemblies 1 and 2 from Phase 2.

Step 2: Attach Assembly 1 to fort structure by fastening angled legs I to floor supports C using (2) 5" hex bolts, (2) 5/16" flat washers, (2) 5/16" split washers, and 5/16" t-nuts each angled leg (Fig. 5).

Step 3: Attach Assembly 2 to fort structure by fastening angled legs I to floor supports C using (2) 5" hex bolts, (2) 5/16" flat washers, (2) 5/16" split washers, and 5/16" t-nuts each angled leg (Fig. 5).

Step 4: Secure tops of angled legs to uprights using (1) 4 1/2" lag screw and (1) 5/16" flat washer each (Fig. 6).

Step 5: Once legs are secured to the fort structure, make sure they are perpendicular to the ground beams and tighten bolts left loose in Phase 2.

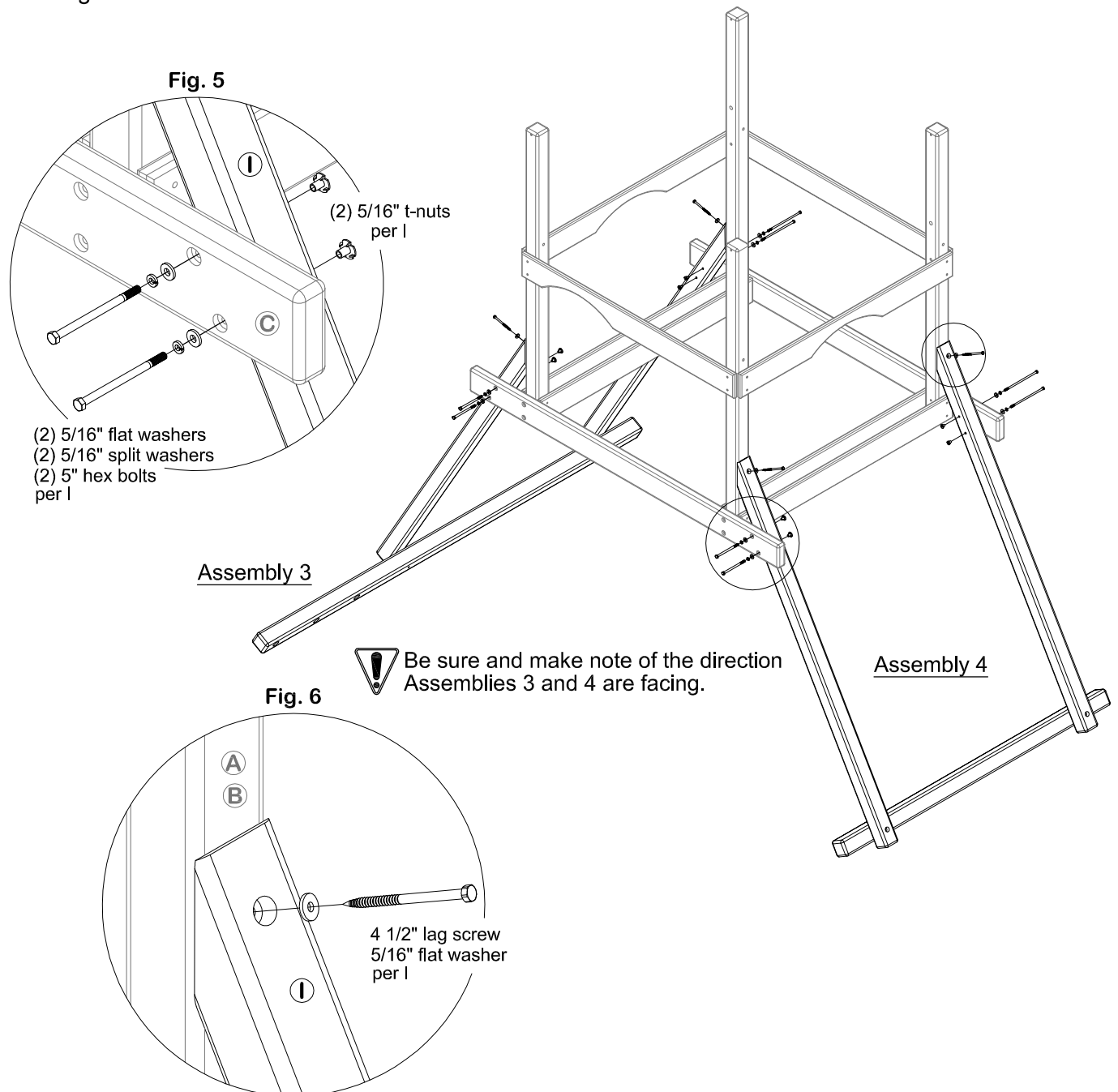

Phase 4 Gusset Attachment

Items Used in this Phase
(4) 'J' - 4x6x009 15/16 Angle Support Braces
(1) 'K' - 5/4x6x057 Floor Support
(2) 'AQ' - L-brackets (green)

Step 1: Gather items J(4), K(1), AQ(2) and hardware bag.

Step 2: Attach support braces J to angled legs I and ground beams using (3) 4 1/2" lag screws and (3) 5/16" flat washers each (Fig. 7).

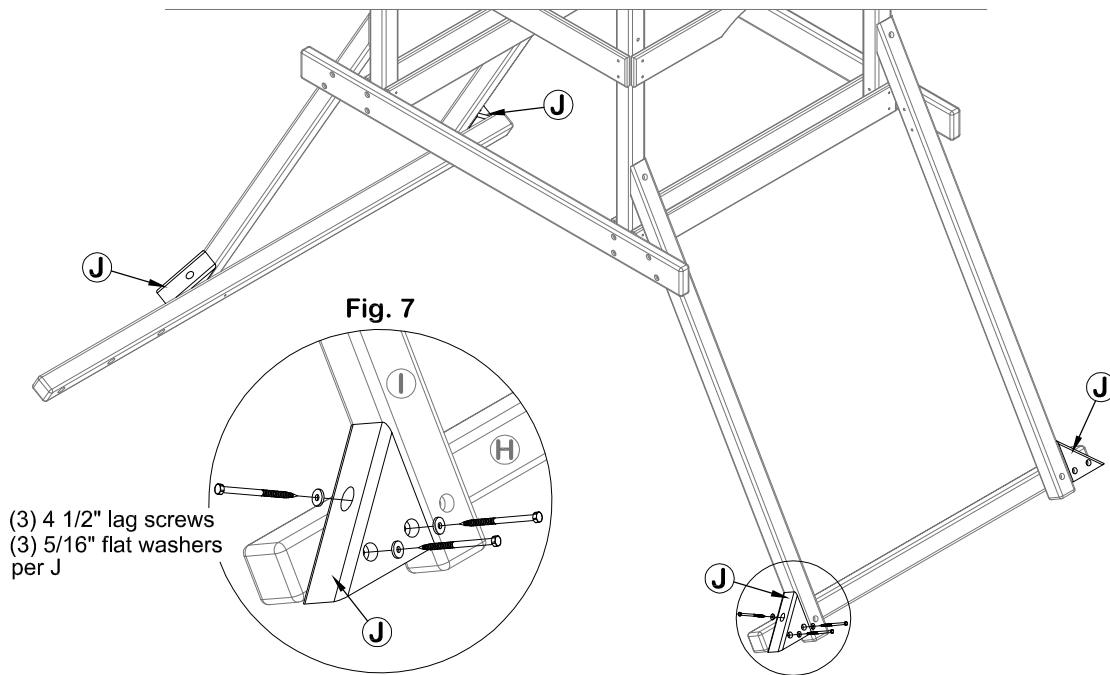

Step 3: Attach floor joist K to floor supports C using (2) L-brackets AQ and (4) 1" tapping screws (Fig. 8).

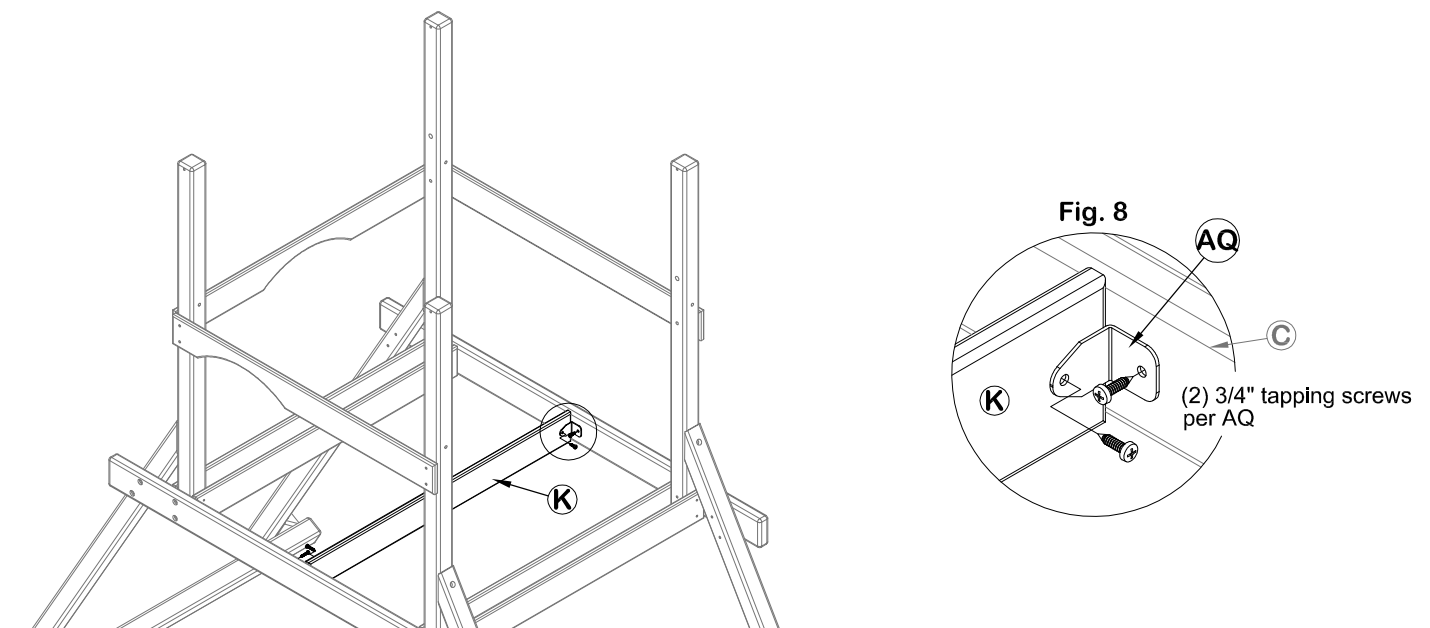

Phase 5 Floor Assembly

Items Used in this Phase

- (2) 'L' - 5/4x6x050 End Floor Boards
- (3) 'M' - 5/4x6x074 Floor Panel Assemblies
- (1) 'O' - 5/4x4x030 1/4 Wall Rail
- (1) 'P' - 5/4x4x057 Wall Rail

Step 1: Gather items L(2), M(3), O(1), P(1) and hardware bag.

Step 2: Place panels M on floor joists as shown below so that cleats sit between floor joists E on each end and attach using (7) 2 1/4" deck screws each.

Step 3: Place boards L on outside of panels M and attach using (5) 2 1/4" deck screws each.

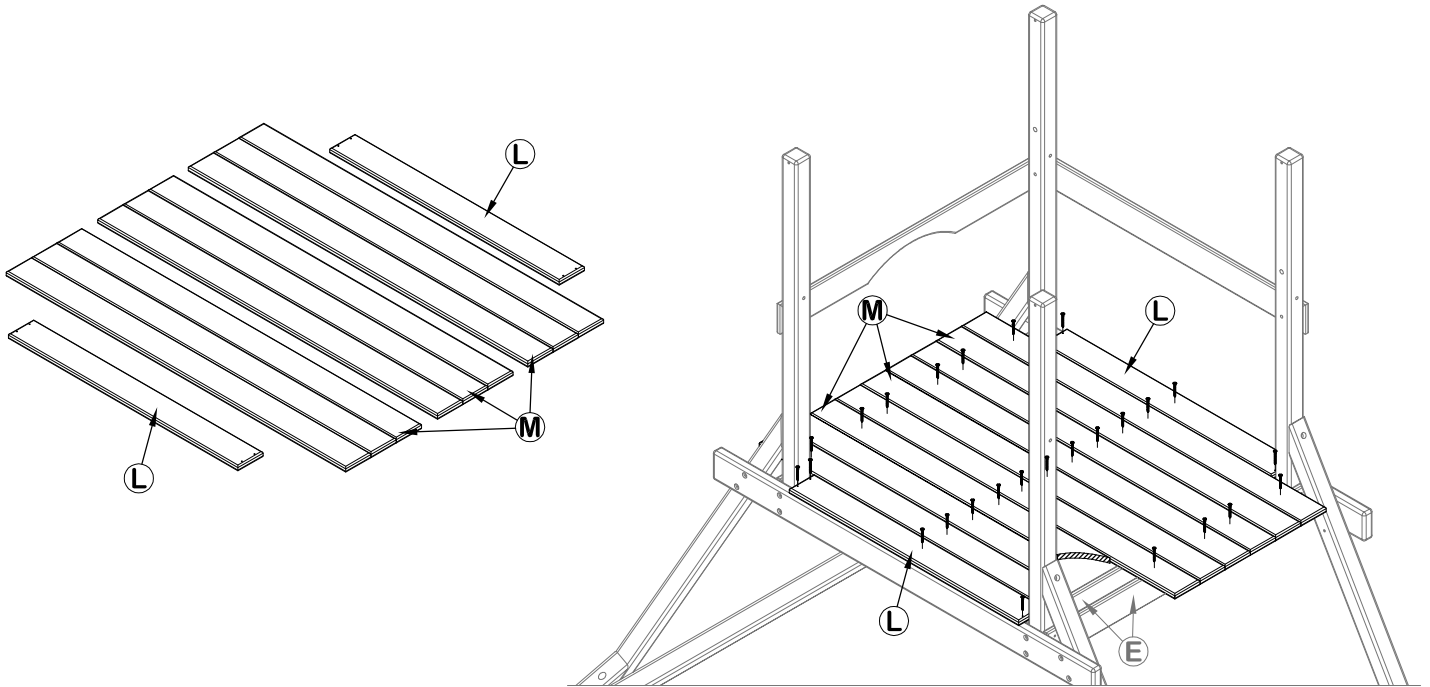

Step 3: Attach wall rails O and P to uprights as shown using 2 1/2" tapping screws and 5/16" flat washers (Fig. 9).

Fig. 9

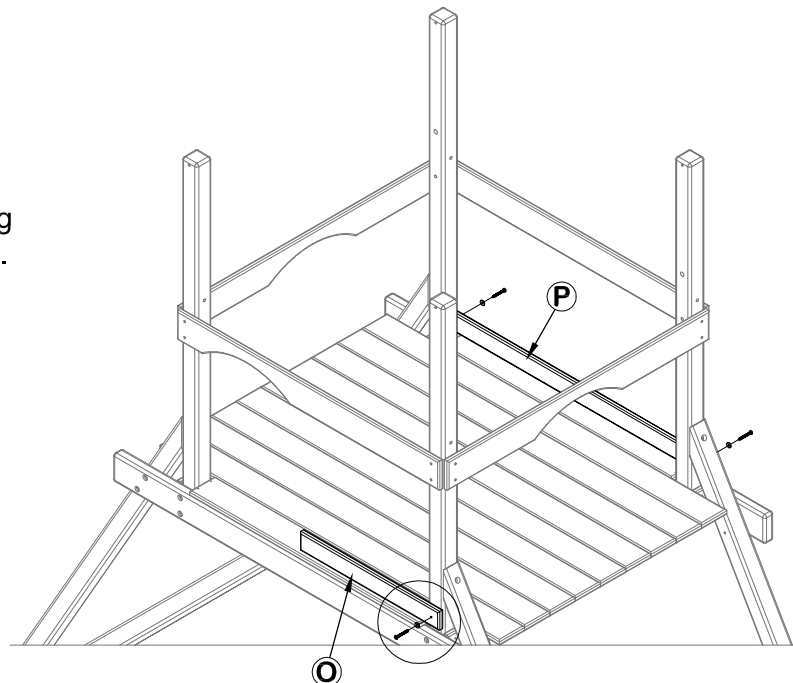
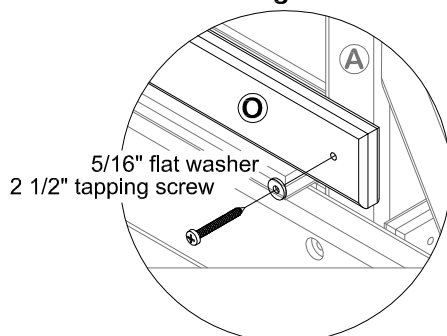

Phase 6 Rockwall Assembly

Items Used in this Phase

- (1) 'Q' - Rockwall Assembly (4 board)
- (2) 'R' - Rockwall Assemblies (6 board)
- (1) 'S' - 5/4x4x059 3/4 Rockwall Board
- (1) 'T' - 5/4x6x057 Rockwall Board
- (1) 'U' - 5/4x4x062 Rockwall Brace
- (2) 'BD' - Assorted Climbing Rocks (bag of 6)

Step 1: Gather items Q(1), R(2), S(1), T(1), U(1) and hardware bag.

Step 2: Attach board T so that it's touching the underside of the floor using (4) 2 1/2" tapping screws and (4) 5/16" flat washers (Fig. 10).

Step 3: Center and attach board S directly below board T using (4) 2 1/4" deck screws (Fig. 10).

Step 4: Place panels Q and R(2) below board S as shown below and attach using (4) 2 1/4" deck screws per panel assembly (Fig. 10). Note the rotation of each panel.

Step 5: Center rockwall brace U under rockwall and attach using (20) 1 1/2" deck screws as shown.

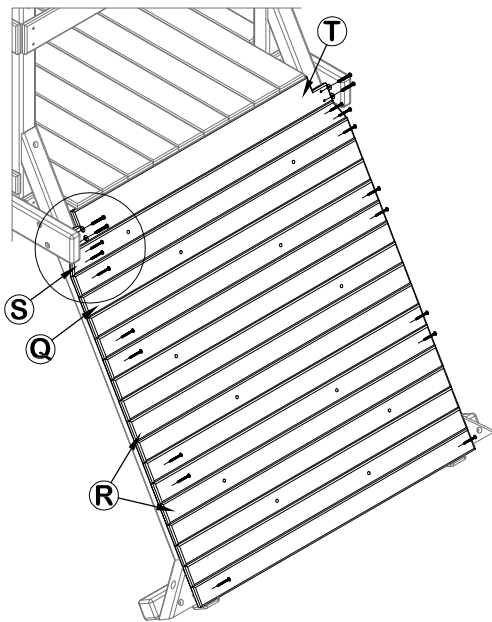
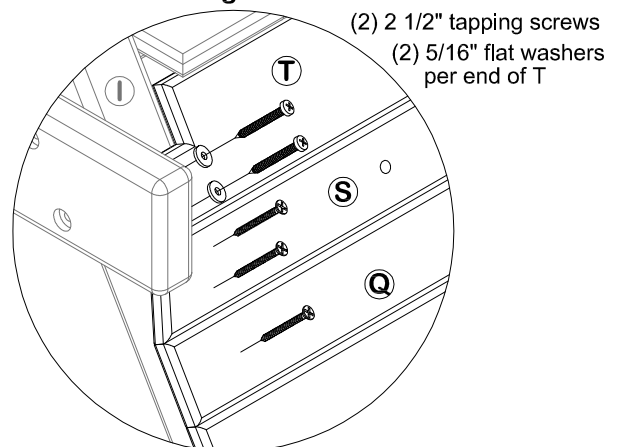

Fig. 10



2 1/4" deck screws

! Please note the orientation of panels. Each panel rotates 180° as they are placed. This is to allow more variation of rock placements on rock wall.

Step 6: Place rocks on panels with the grips facing up and fasten to pre-drilled holes using 1 1/2" hex bolts, 5/16" split washers, 5/16" t-nuts and 1 1/4" deck screws as shown below.

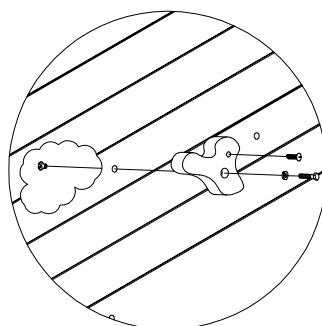

- (12) 1 1/2" hex bolts
- (12) 5/16" split washers
- (12) 5/16" t-nuts
- (12) 1 1/4" deck screws

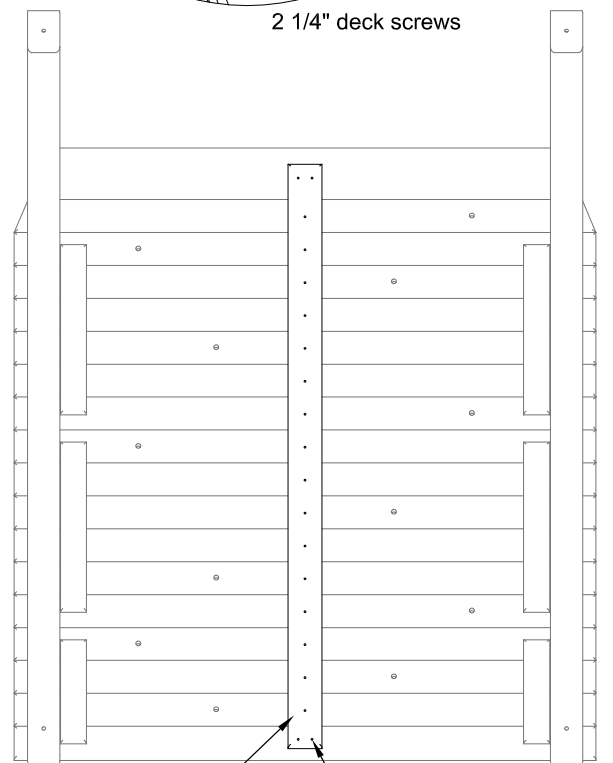

(20) 1 1/2" deck screws

Phase 7 Ladder Assembly & Attachment

Items Used in this Phase

- (2) 'E' - 5/4x6x057 Wall Rails
- (5) 'AJ' - 2x6x020 1/4 Ladder Rungs
- (1) 'AK' - 2x6x062 Ladder Rail (Left)
- (1) 'AL' - 2x6x062 Ladder Rail (Right)
- (4) 'AQ' - L-brackets (green)
- (2) 'AU' - 4' Handrails (green)

Step 1: Gather items E(2), AJ(5), AK(1), AL(1), AQ(4), AU(2) and hardware bag.

Step 2: Place AK and AL so the dado cuts are facing each other. Place rungs AJ in dado cuts and attach using (2) 2 1/4" deck screws on each side as shown below.

Step 2: Place hand rails AU on AK and AL. Insert 2" carriage bolt through hole in handle and pre-drilled hole on top of AK and AL. Secure using 5/16" flat washer, 5/16" split washer, and 5/16" acorn nut (Fig. 11).

Step 4: Screw (2) 1" tapping screws to bottom of hand rails. Attach brackets AQ to top of AK and AL using 5/16" t-nut in inside of deck ladder and 1 1/2" hex bolt, 5/16" flat washer, and 5/16" split washer.

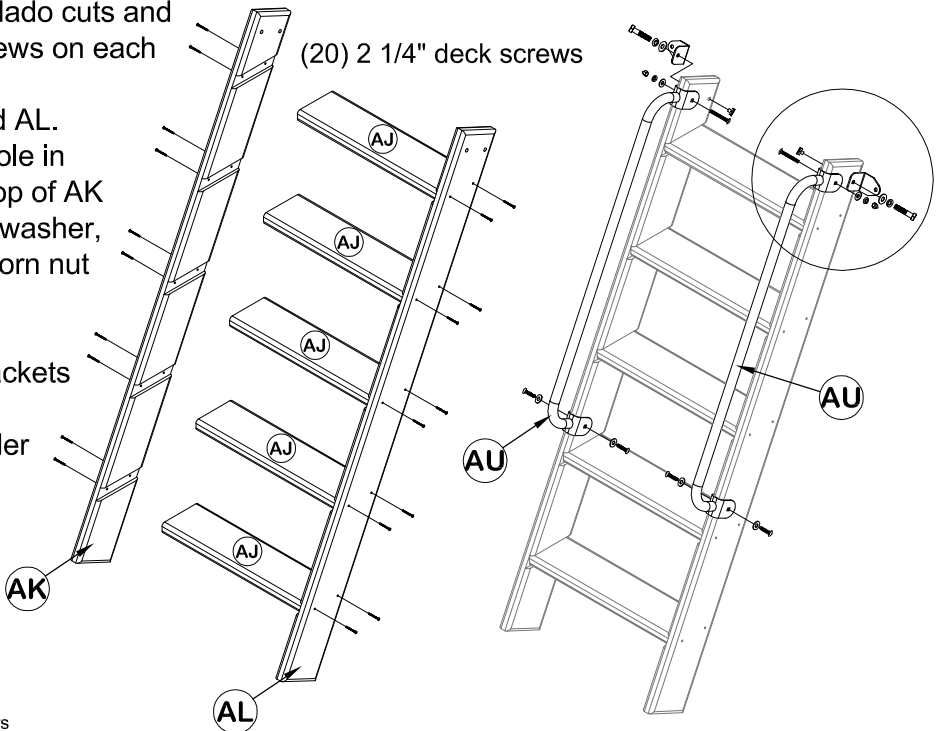
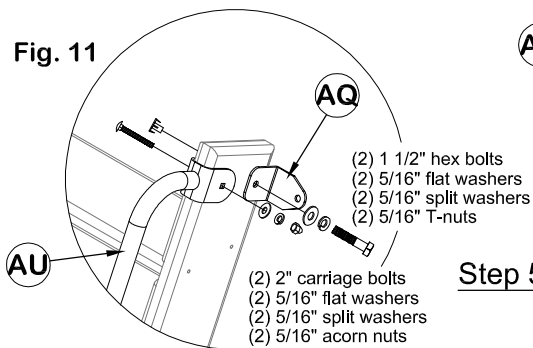

Fig. 11



Step 5: Attach (2) wall rails E to legs using 2 1/2" tapping screws and flat washers as shown below. Center ladder on boards E horizontally and vertically. Transfer holes on each bracket at top of ladder to E using 3/8" [10mm] bit. Secure top of deck ladder using t-nuts under E and 1 1/4" hex bolt, 5/16" flat washer, and 5/16" split washer (Fig. 12). Secure the bottom of the deck ladder with (2) brackets AQ, 1" tapping screws and flat washers to bottom E.

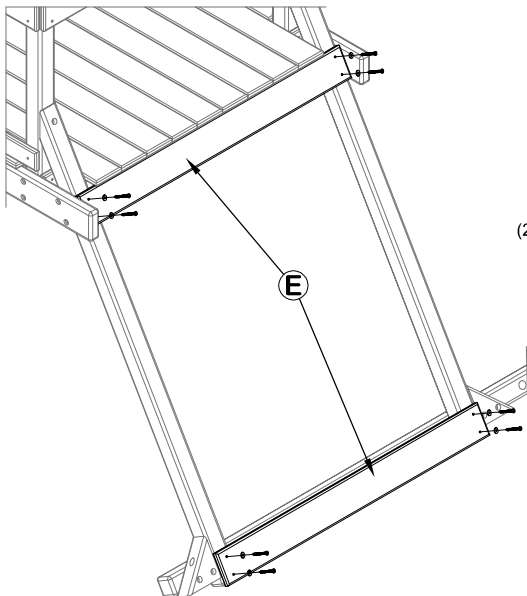
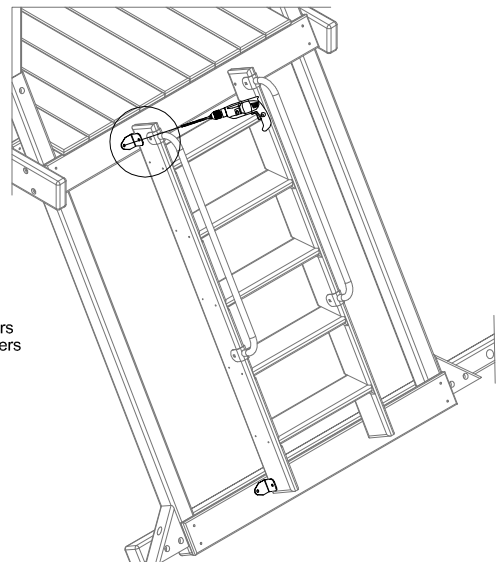
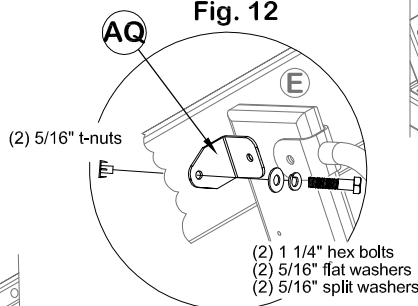

Fig. 12



Phase 8 Wall Slat Attachment

- Items Used in this Phase**
- (2) 'N' - 5/4x4x019 Wall Rails
 - (20) 'V' - 1x4x027 1/4 Wall Slats
 - (5) 'AQ' - L-brackets (green)

All Wall Slats Must Be 1 1/2" [38mm] Off The Fort Floor.

Step 1: (Full Wall) Fasten (2) slats V to rails E and P, butted up to uprights (one on each side) using (4) 1 1/2" deck screws each. Install remaining slats leaving a 2 3/8" [60mm] gap and fasten using (4) 1 1/2" deck screws each.

Step 2: (Activity Wall) Fasten (1) slat V to rails D and O, butted up to uprights using (4) 1 1/2" deck screws. Install slat V (specified 2nd) against rails D and O with ends flush, fasten with (4) 1 1/2" deck screws. Install remaining slats leaving a 2 3/8" [60mm] gap and fasten using (4) 1 1/2" deck screws each. Secure wall by attaching bracket AQ to rail O and floor using (2) 3/4" tapping screws (Fig. 13).

Step 3: (Ladder Wall) Place rails N on each side of opening flush with outside of uprights. Attach (2) slats V to rails F and N, butted up to uprights on each side using (4) 1 1/2" deck screws each. Install remaining slats V leaving a 2 3/8" [60mm] gap and fasten using (4) 1 1/2" deck screws each. Secure rails N to floor using (2) brackets AQ and (4) 3/4" tapping screws each (Fig. 13).

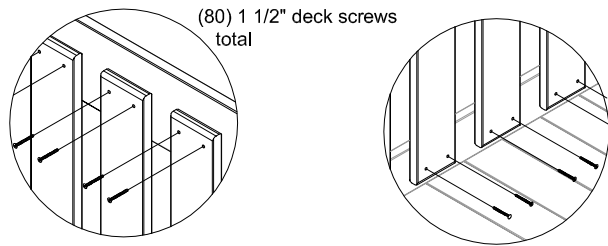

! All slats must be 1 1/2" [38mm] off fort floor during the installation.

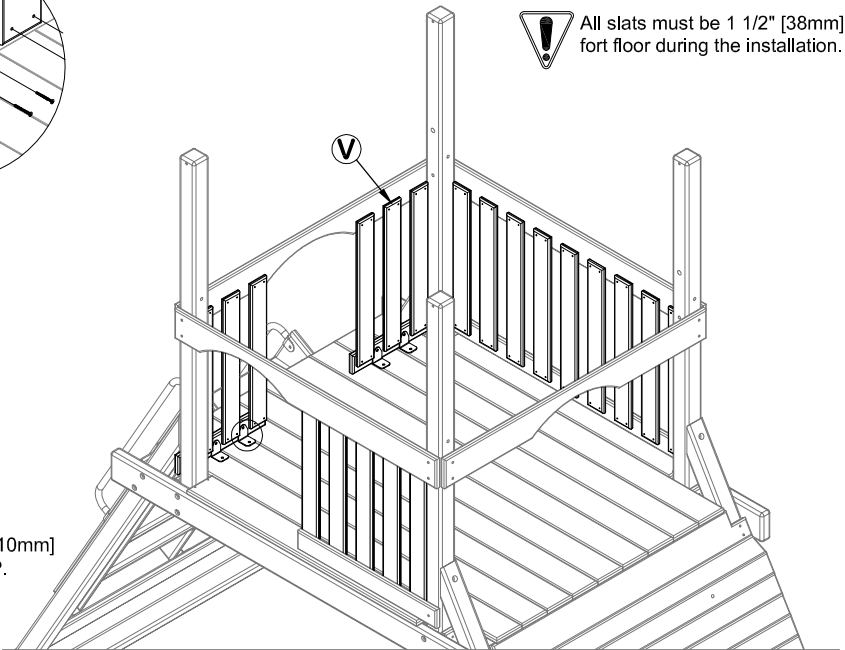
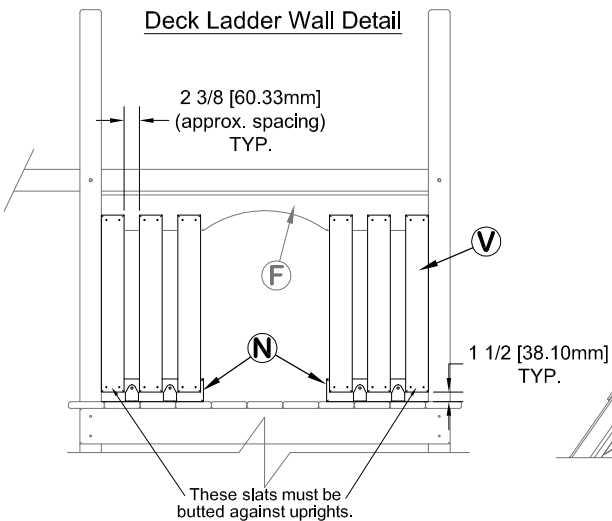

NOTE: No wall slats are used on rock wall side.

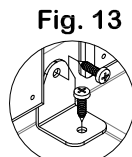
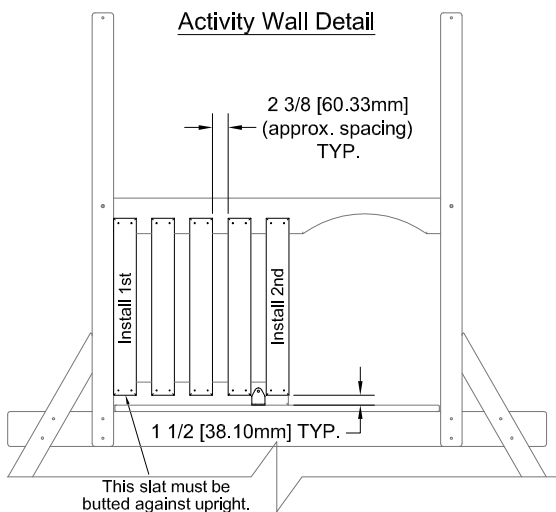
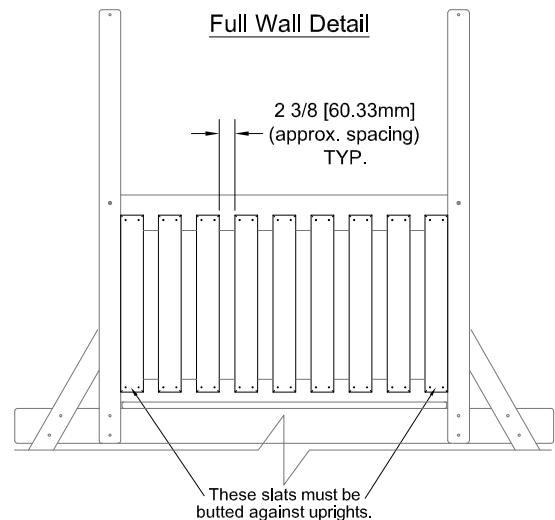

Fig. 13
(2) 3/4" tapping screws per AQ



Phase 9 Acc. Arm & Cross Brace Attachment

Items Used in this Phase

- (1) 'P' - 5/4x4x057 Wall Rail
- (1) 'W' - 4x4x094 Rope Ladder Accessory Arm
- (1) 'X' - 4x4x094 Trapeze Accessory Arm
- (1) 'Y' - 4x6x057 Cross Brace
- (2) 'AP' - 2x82" Metal Strips
- (2) 'AR' - Cross Brace Clamps

Step 1: Gather items P(2), W(5), X(1), Y(1), AR(4) and hardware bag.

Step 2: Attach rope ladder accessory arm W to uprights on same side as rope ladder ground beam using (2) 6 1/2" hex bolts, (4) 5/16" flat washers and (2) 5/16" lock nuts.

Step 3: Attach trapeze accessory arm X to uprights on opposite side using (2) 6 1/2" hex bolts, (4) 5/16" flat washers and (2) 5/16" lock nuts (Fig. 14).

Step 4: Center and attach (1) metal strip AP to each accessory arm using (4) 2" lag screws and (4) 5/16" flat washers each.

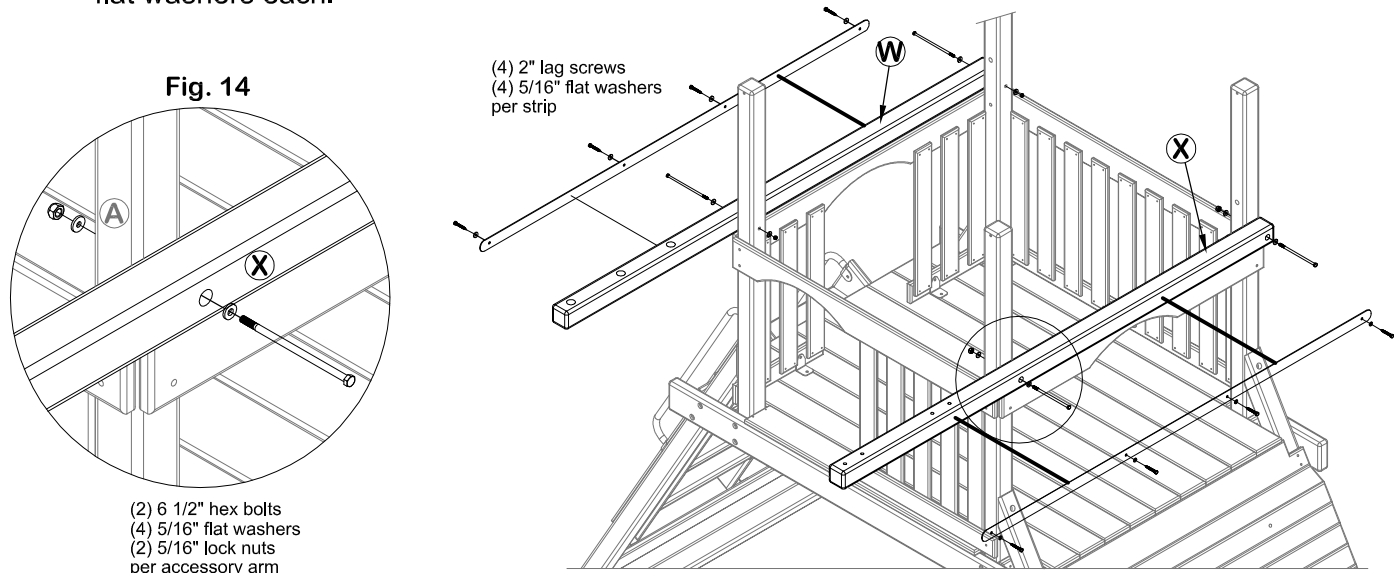

Step 4: Attach cross brace Y to uprights using clamps AR, 7 1/2" carriage bolts, 1/2" flat washers, 1/2" split washers, 1/2" acorn nuts and 1" tapping screws (Fig. 15).

****NOTE: If attaching a single beam or monkey bar, refer to those instructions and attach the respective attachment clamps to cross brace Y before continuing.**

Step 5: Center wall rail P vertically between cross brace Y and wall rail E and attach using (2) 2 1/2" tapping screws and (2) 5/16" flat washers (Fig. 15).

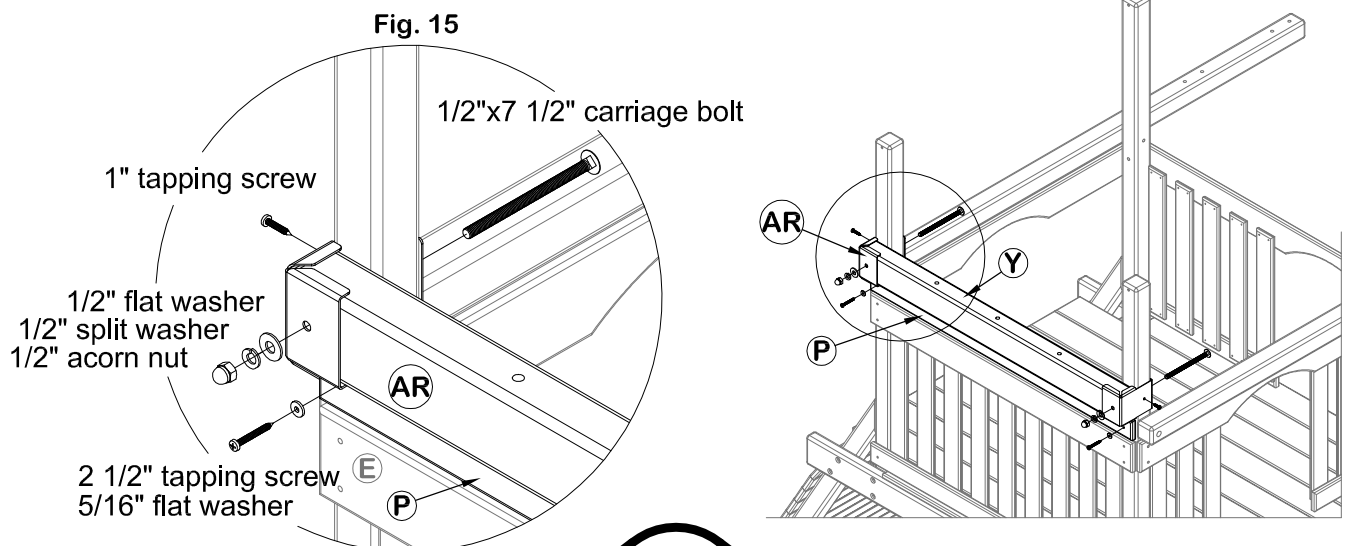



ATTENTION



Before beginning assembly, please replace pages 18 & 19 in the instructions included with the Mountaineer with the pages 18 & 19 included in this box. Also, you will need to discard the following boards:

DISCARD (included with fort boxes)

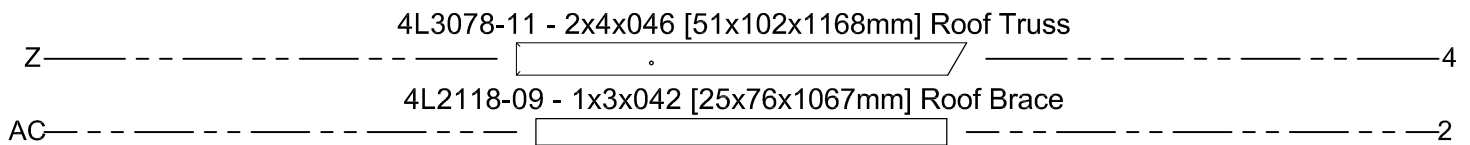

REPLACE WITH (included in this box)

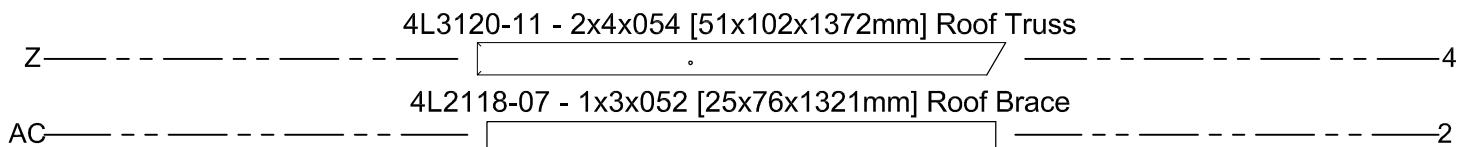

There are also additional pieces in this box required for assembly, they are as follows:

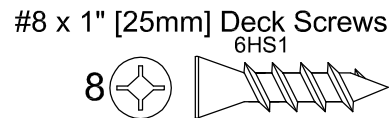
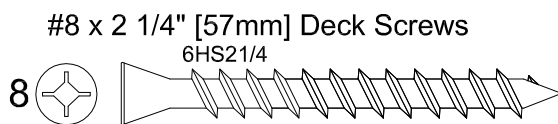
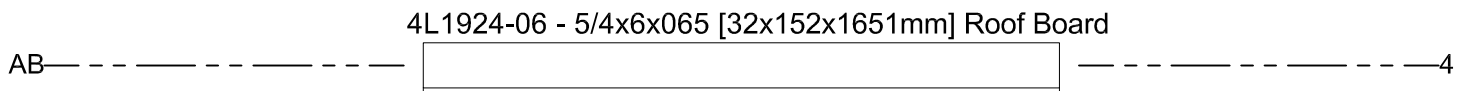

Phase 10 Roof Assembly

Items Used in this Phase

- (4) 'Z' - 2x4x054 Roof Trusses
- (6) 'AA' - 65" Roof Panel Assemblies
- (6) 'AB' - 5/4x6x065 Roof Boards
- (2) 'AT' - Mending Plates

Step 1: Gather items Z(4), AA(6), AB(6), AT(2) and hardware bag.

Step 2: Attach roof trusses Z to uprights A and B using 4 1/2" hex bolts, 5/16" flat washers, 5/16" split washers, and 5/16" t-nuts (Fig. 16). Leave slightly loose so trusses can be rotated.

Step 3: Rotate roof trusses to center of fort so they meet and attach together using mending plate AT and (4) 1" tapping screws each (Fig. 17). Tighten bolts from Step 2.

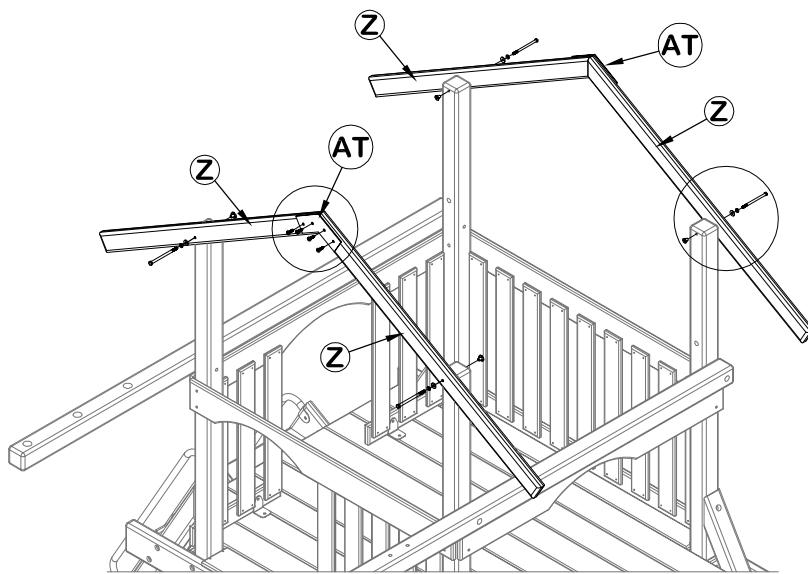

Fig. 16

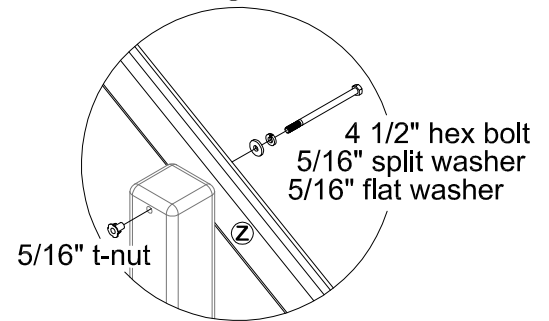
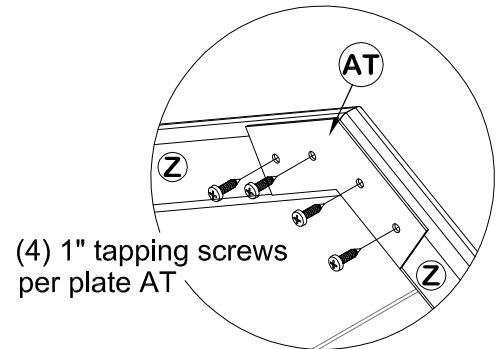
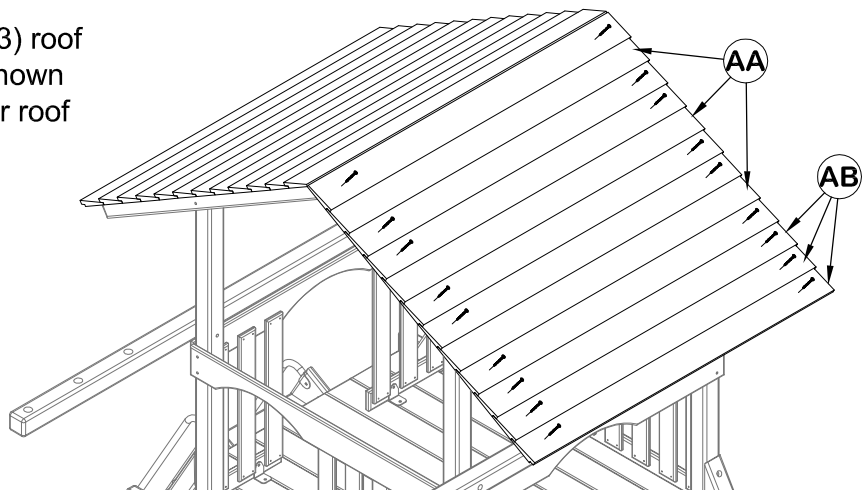

Fig. 17



Step 4: Attach (3) roof panels AA and (3) roof boards AB to each roof half as shown using (18) 2 1/4" deck screws per roof half.



Phase 11 Roof Assembly

Items Used in this Phase

- (2) 'AC' - 1x3x052 Roof Braces
- (2) 'AD' - 2x4x005 1/2 Roof Swedges
- (1) 'AE' - 2x2x065 Roof Ridge Cap

Step 1: Gather items AC(2), AD(2), AE(1) and hardware bag.

Step 2: Center and attach roof braces AC to each roof half using (10) 1" deck screws per half.

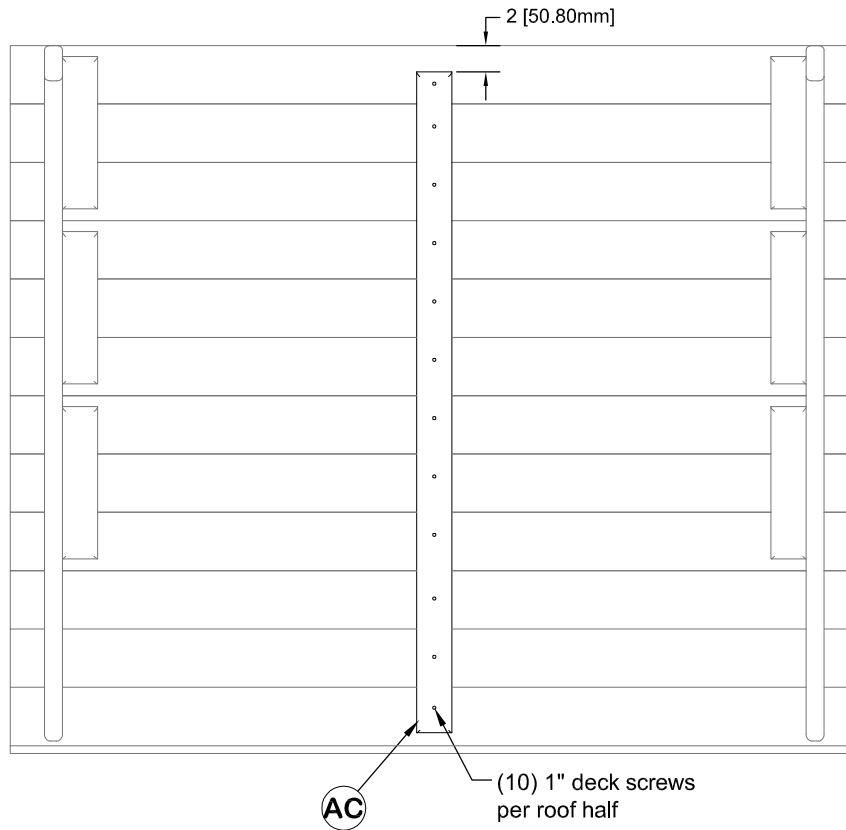

Step 3: Place ridge cap AE on top of roof and attach from below using swedges AD and (4) 1 3/4" deck screws.

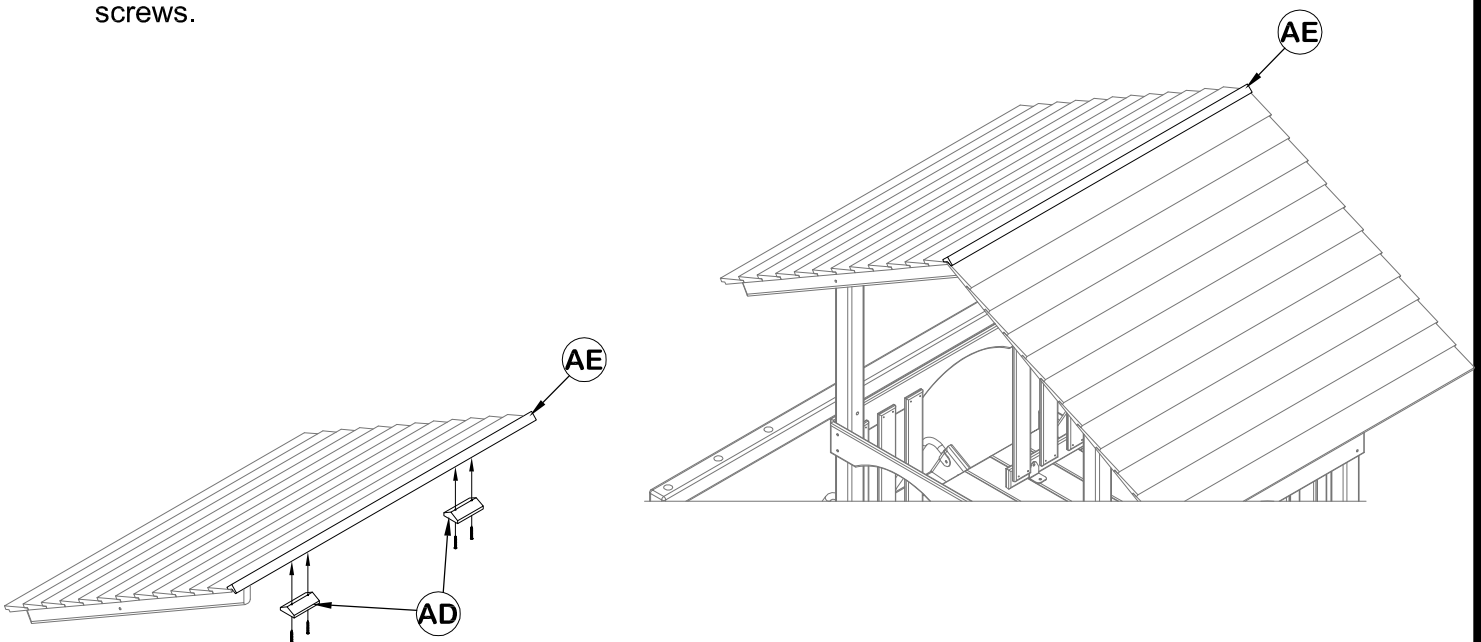

Phase 12 Sunburst Assembly

Items Used in this Phase

- (2) 'AF' - 1x3x012 Sunburst Vertical Spokes
- (2) 'AG' - 1x6x008 Sunburst Center Pieces w/Logo
- (4) 'AH' - 1x3x009 1/4 Sunburst Spokes
- (2) 'AI' - 1x3x044 1/4 Sunburst Horizontal Rails

Step 1: Gather items AF(2), AG(2), AH(4), AI(2) and hardware bag.

Step 2: Place the Logo plate face down. Layout the sunburst boards as shown below on top of the plate.

Screw through the sunburst boards as shown with (8) 1 1/4" deck screws.

Step 3: Attach assembled sunburst to the inside of the roof trusses as shown. Use 1 1/2" deck screws as shown.

To avoid splitting boards pre-drill boards 1" from edge before attaching.

SUNBURST DETAIL

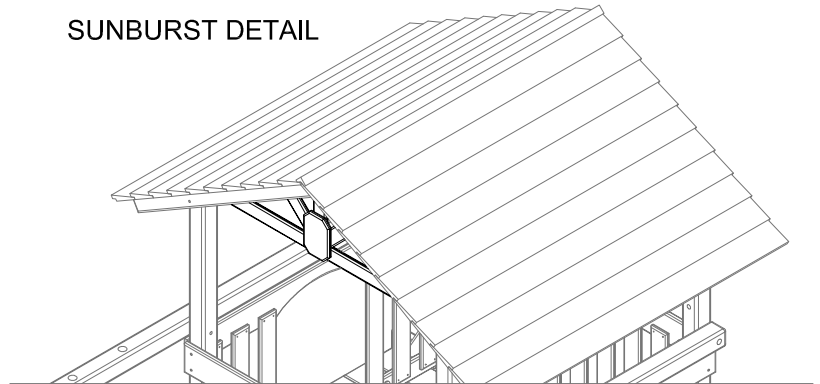

Position sunburst behind roof trusses and attach with 1 1/2" deck screws.

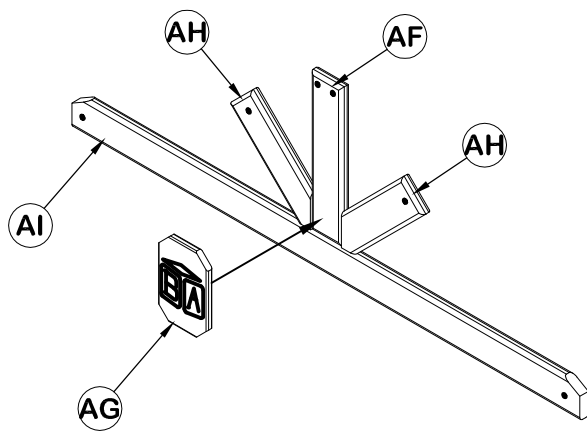

Center Line

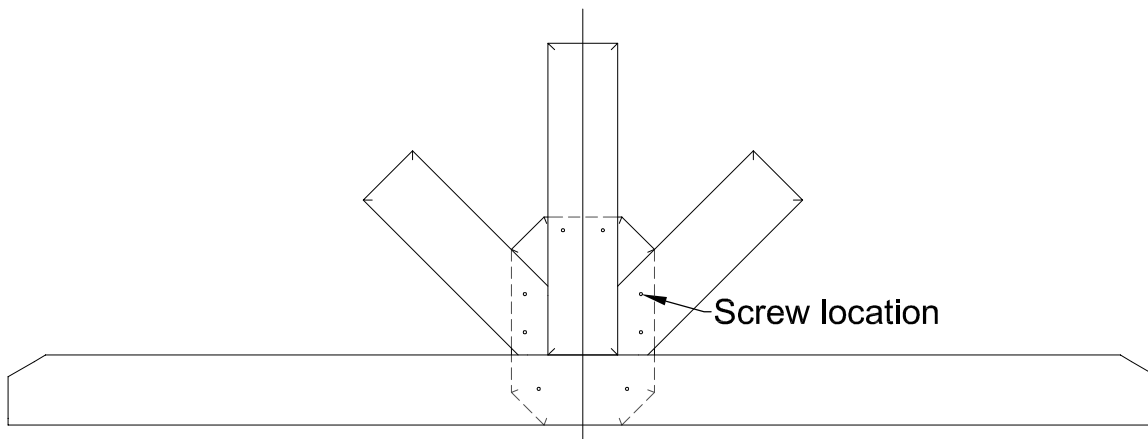

NOTE: DO NOT OVER TIGHTEN SCREWS.

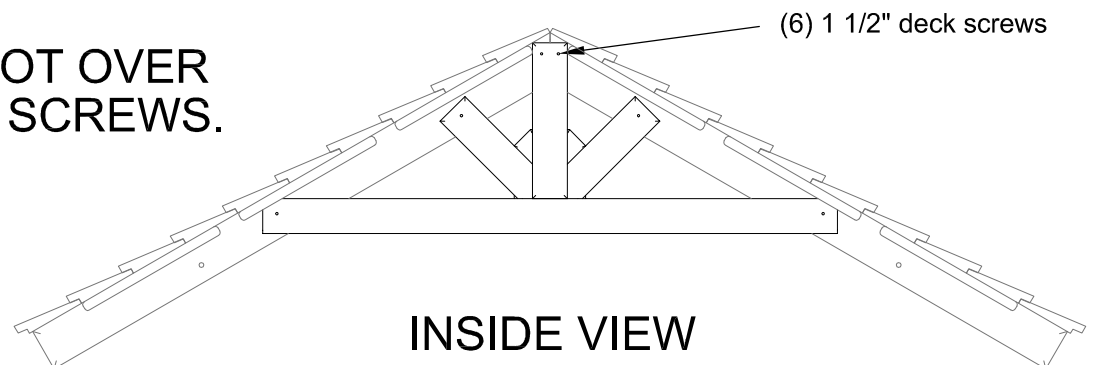

INSIDE VIEW

Phase 13 Rope Ladder Assembly

Items Used in this Phase

- (6) 'AO' - 2x4x027 Rope Ladder Rungs
- (3) 'AV' - 1"x15' Green Ropes

Step 1: Gather items AO(6) and AV(3).

Step 2: Feed ropes AV through front face of ground beam G and tie knots near ends of rope. **(Keep each of the 3 rope sections even as you assemble ladder.)** It is important that as you space rungs AO along the ropes, you tie a knot at the proper location that will hold the rungs 11 3/8" [289mm] apart as shown. Continue with the rung installation until all rungs AO are in place. Feed remaining portion of rope through bottom of accessory arm W and tie knots on top side.

****NOTE**** Gap between all rungs and accessory arms are not to be less than 10" when installation is complete.

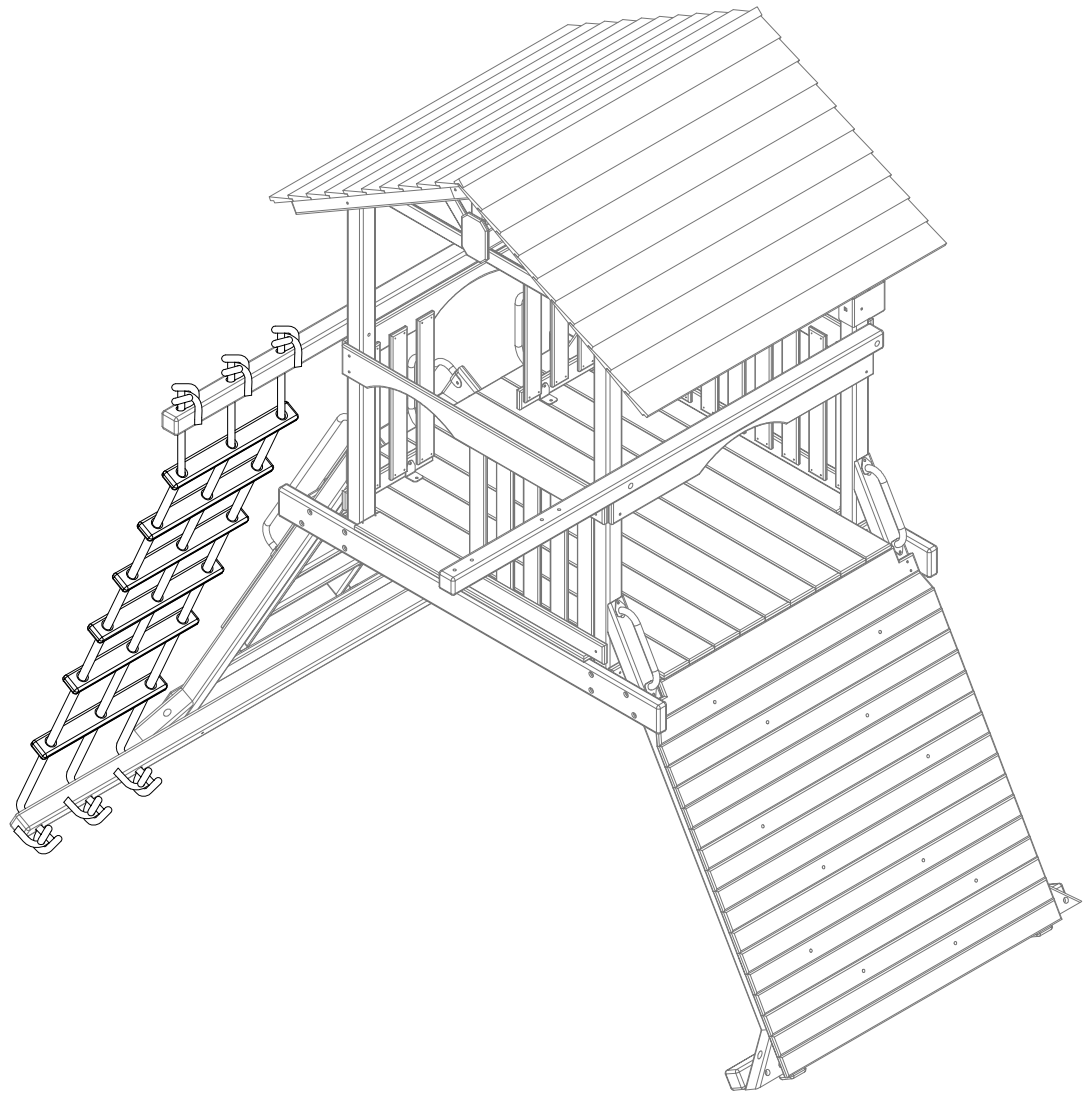
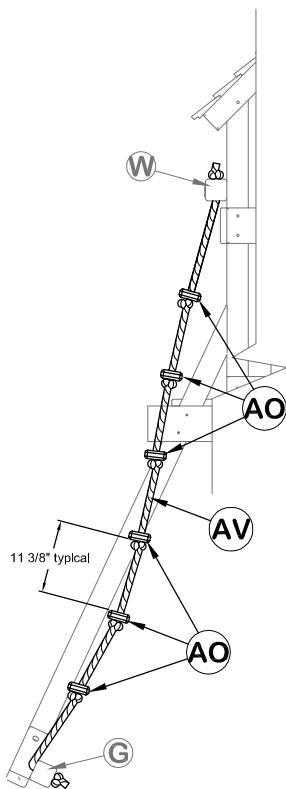

Phase 14 Trapeze Attachment

Items Used in this Phase

- (1) 'AW' - 36" Green Trapeze
- (2) 'AX' - Large Swing Hangers
- (2) 'BG' - Snap Links

Step 1: Gather AW(1), AX(2), BG(2) and hardware bag.

Step 2: Attach swing hangers AX to trapeze accessory arm X using (2) 4" hex bolts, (4) 5/16" flat washers, and (2) 5/16" lock nuts each (Fig. 18).

Step 3: Attach trapeze assembly AW to swing hangers AX using snap links BG (Fig. 18).

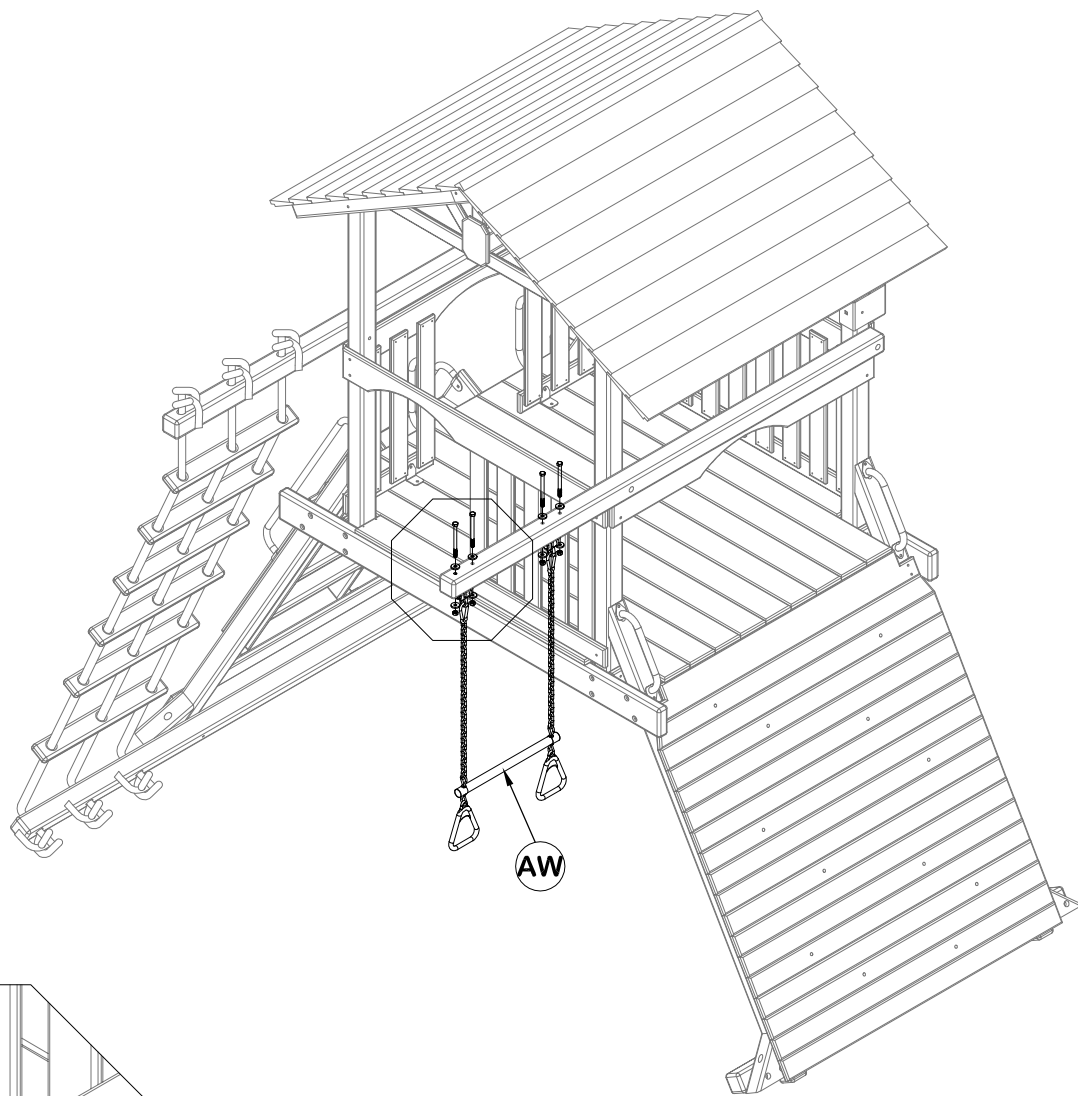
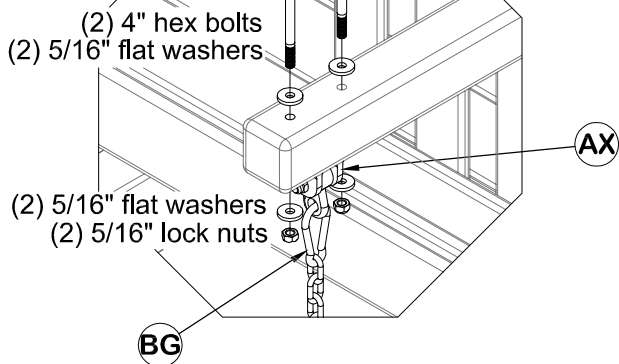

Fig. 18



Phase 15 Tire Swing Attachment

Items Used in this Phase

- (1) 'AN' - 4x4x021 Tire Swing Mounting Block
- (3) 'AY' - 30" Green Chains
- (3) 'AZ' - Clevis Links
- (1) 'BA' - Tire Swivel
- (3) 'BB' - Tire Eye Bolts
- (1) 'BC' - Tire
- (1) 'BG' - Snap Link

Step 1: Gather AN(1), AY(3), AZ(3), BA(1), BB(3), BC(1), BG(1) and hardware bag.

Step 2: Place mounting block AN against bottom of fort floor, flush with floor joist K, and centered. Using hole pattern in block AN, drill through floor with 3/8" [10mm] drill bit.

Step 3: Take (2) 4" carriage bolts with anti-turn washer and place them in two outside holes in fort floor and fasten block AN. Next, take (2) 5" carriage bolts with anti-turn washer and place them in two inside holes through inside of fort and fasten tire swivel BA (Fig. 20).

Step 4: Assemble Tire Swing as shown in Fig. 19 and install it as shown in Fig. 20.

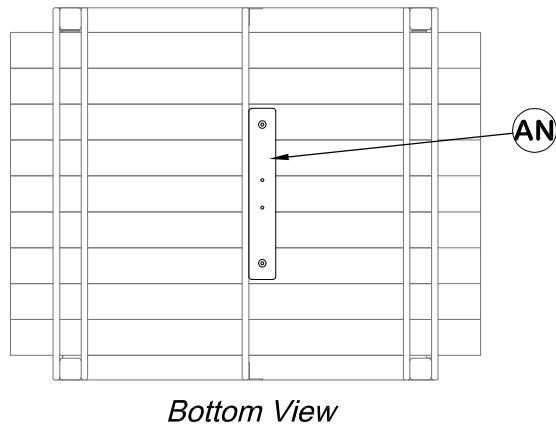

- (2) 5" carriage bolts
- (2) 5/16" anti-turn washers
- (2) 5/16" flat washers
- (2) 5/16" split washers
- (2) 5/16" locking nuts

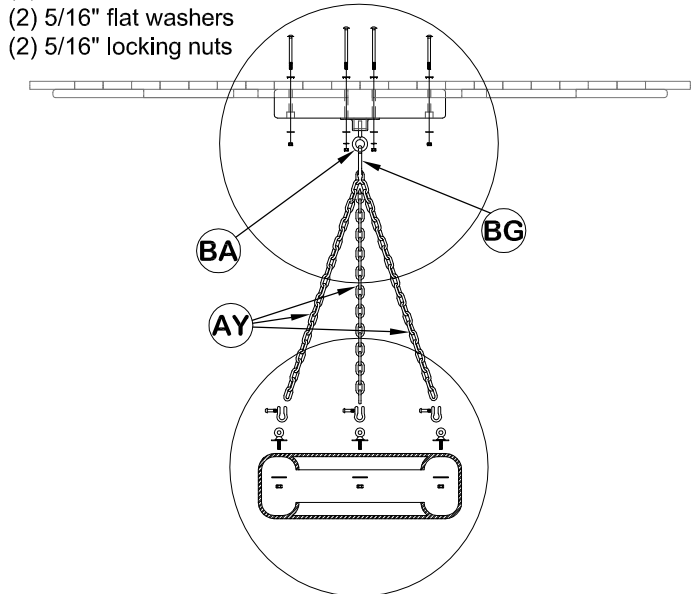

Fig. 20

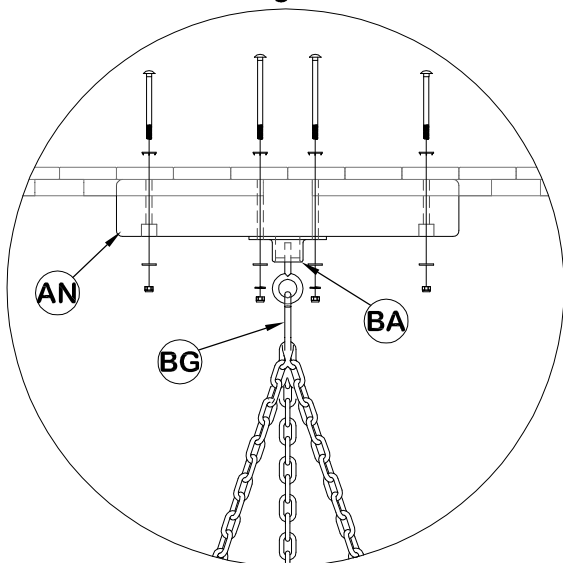
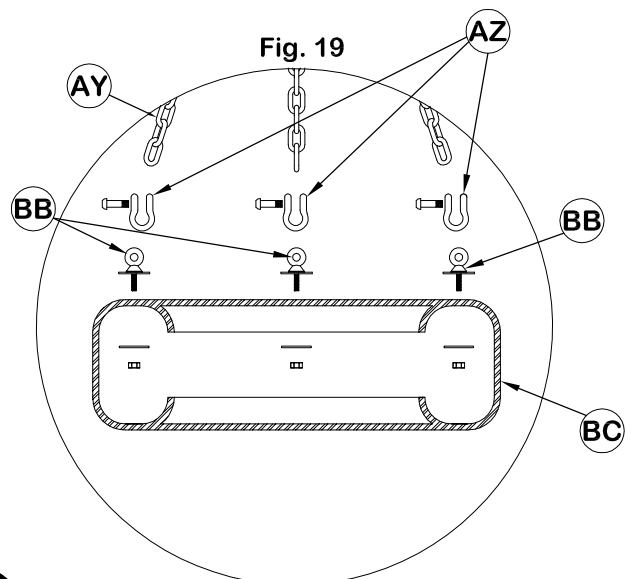

Fig. 19



Phase 16 Grab Handles & Placard Attach.

Items Used in this Phase

(4) 'AS' - Grab Handles (green)

(1) 'BE' - BYA Placard

Step 1: Gather AS(4), BE(1) and hardware bag.

Step 2: Place (2) handles AS centered on inner most wall slats of center opening wall. Drill 5/16" [8mm] hole through each hole of hand grip. Insert 1/4" t-nuts in inside of wall slats. Attach handles AS using 1/4"x1" machine truss screw, 1/4" split washer and 1/4" flat washer through each drilled hole (Fig. 21).

Step 3: Center (2) handles AS on legs I and attach using 2 1/2" tapping screws and 5/16" flat washers (Fig. 22).

Step 4: Attach placard BE to wall rail D using 3/4" tapping screws (Fig. 23).

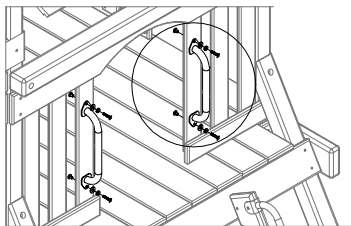
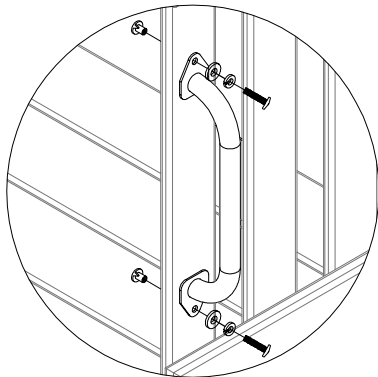

Fig. 21



(2) 1" machine truss screws
(2) 1/4" flat washers
(2) 1/4" split washers
(2) 1/4" t-nuts
per handle AS

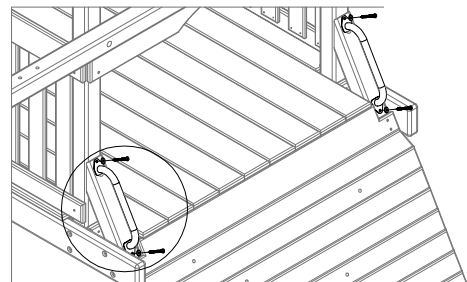
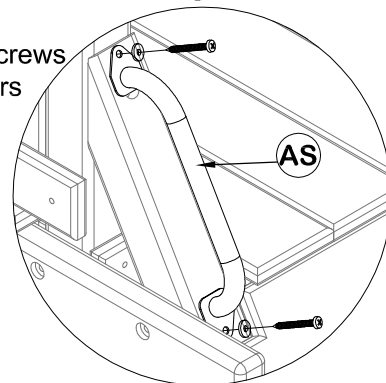

Fig. 22



(2) 2 1/2" tapping screws
(2) 5/16" flat washers
per handle AS

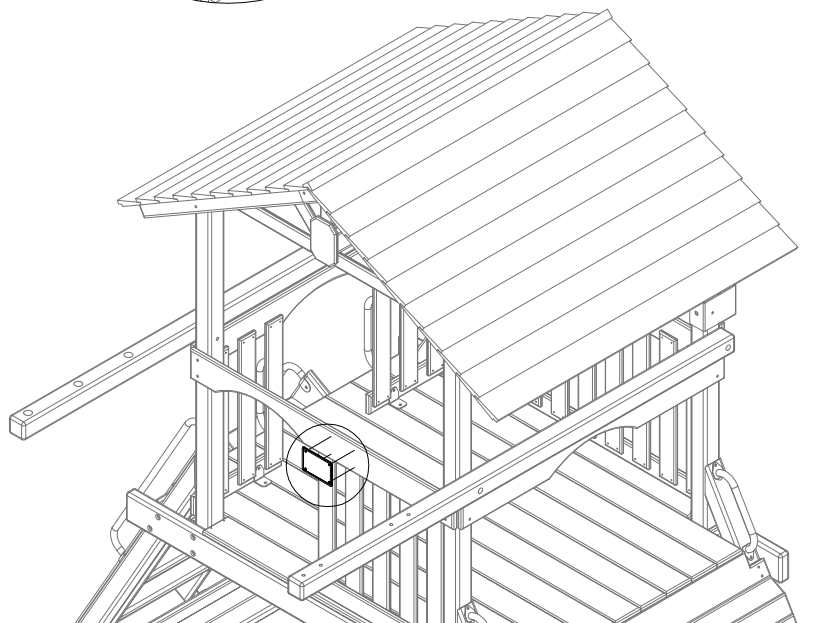
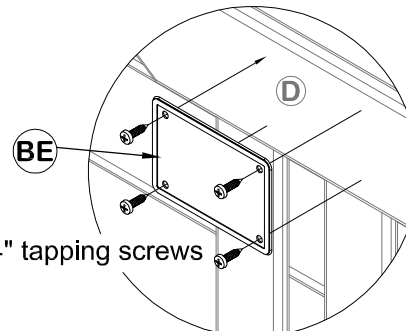

Fig. 23



(4) 3/4" tapping screws

WAVE SLIDE



WAVE SLIDE ATTACHMENT

- * CENTER SLIDE IN WALL OPENING.
- * POSITION TOP OF SLIDE EVEN WITH INSIDE EDGE OF THE FIRST FLOOR BOARD.
- * DRILL (2) 3/8" HOLES THROUGH TOP CORNERS OF SLIDE RECESSES & THRU THE FLOOR.
- * INSERT (2) 5/16 x 2" MACHINE TRUSS SCREWS THROUGH SLIDE & FLOOR.
- * SECURE WITH (2) 5/16" FLAT WASHERS & (2) LOCK NUTS.

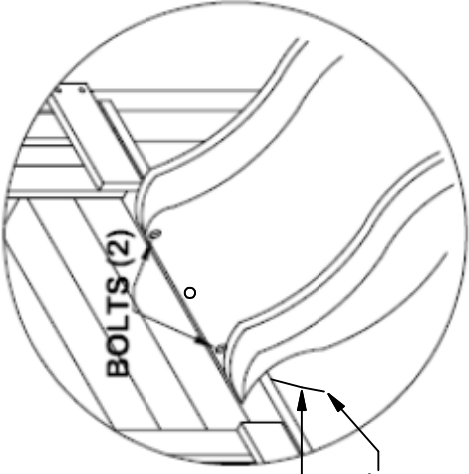

WASHER FLAT 5/16 WZ
(2 PLCS)

NUT LOCK 5/16 WZ
(2 PLCS)

LAG SCREW WH 5/16x2 WZ
(2 PLCS)

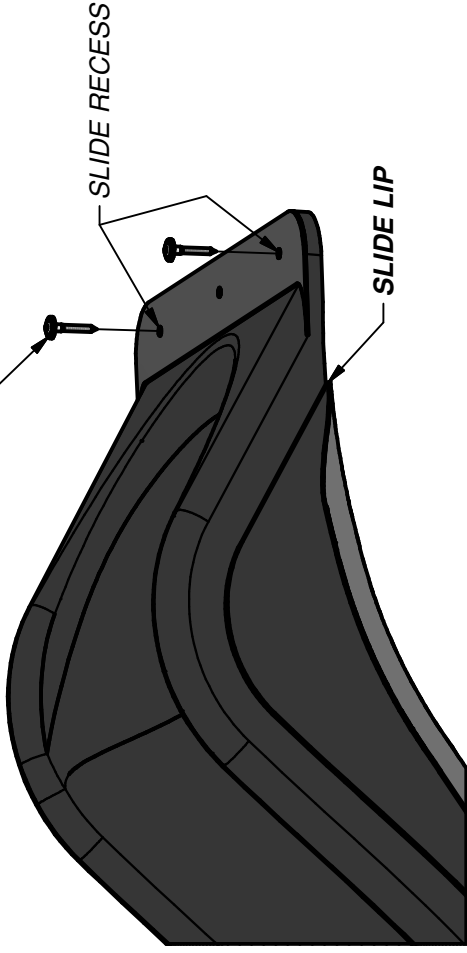

2016 TREEHOUSE SERIES



- * CENTER SLIDE IN WALL OPENING.
- * POSITION BOTTOME LIP OF SLIDE FLUSH WITH EDGE OF THE FLOOR BOARD.
- * DRILL (2) 3/16" PILOT HOLES THRU TOP CORNERS OF SLIDE AT RECESSES & THRU THE FLOOR.
- * ATTACH SLIDE USING (2) LAG SCREWS 5/16 x 2"

Phase 17 Anchoring

Items Used in this Phase
(1) 'BF' - 16" Rebar Stakes (bag of 6)

Step 1: Gather item BF(1) and hardware bag.

Step 2: Drive stakes BF into ground where shown below and attach using 1 1/2" lag screws (Fig. 24).

Step 3: Double check that all hardware is present and tightened properly.

Fig. 24

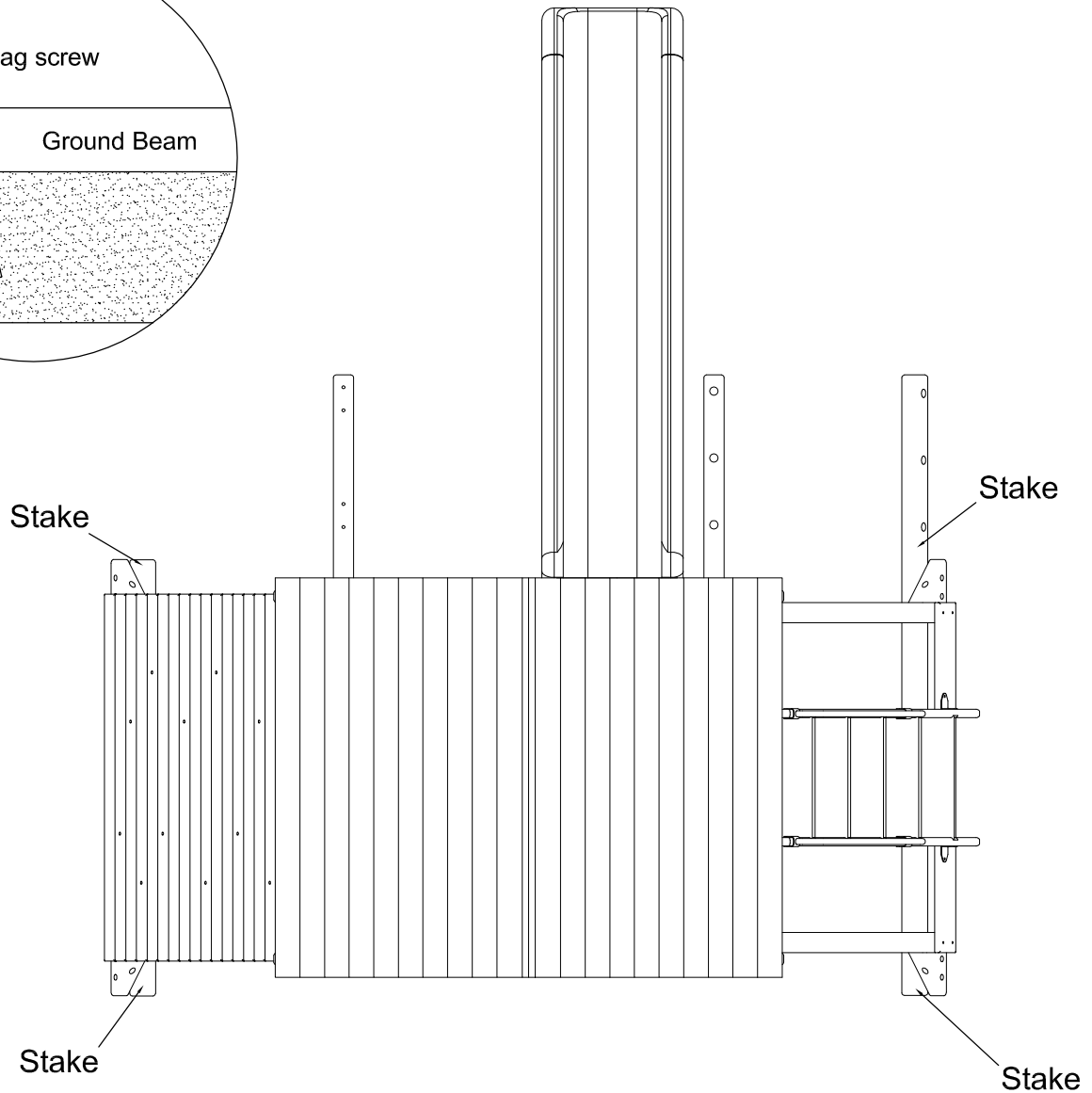
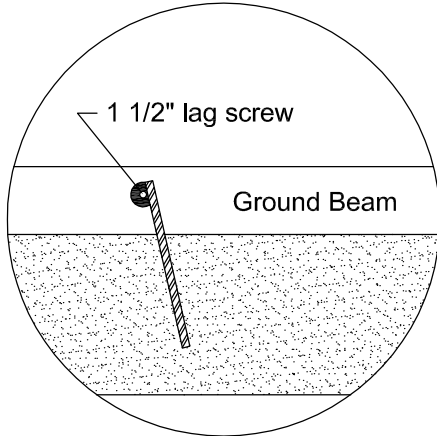

Failure to use stakes can void warranty and cause injury.

Single Beam Option

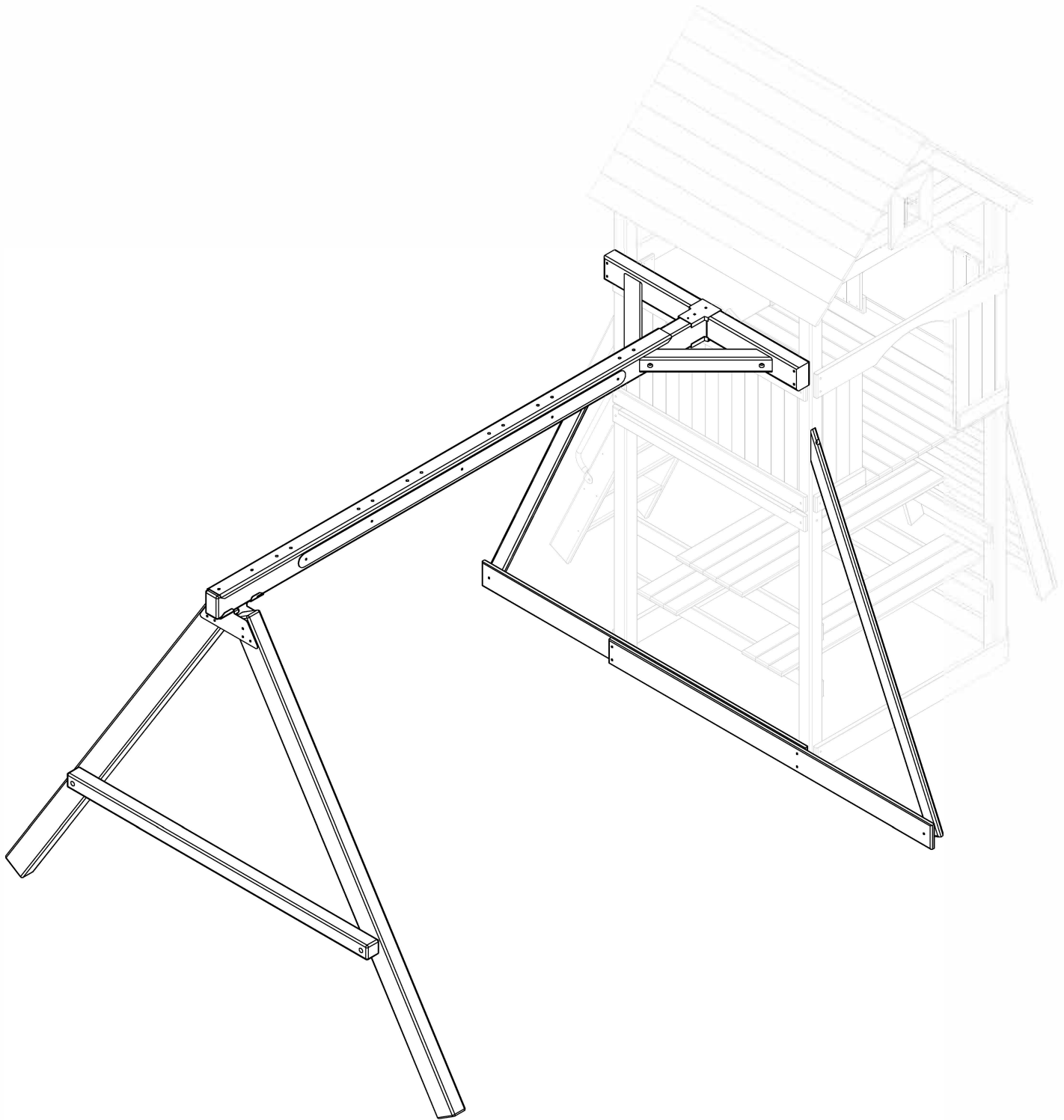



Single Beam

Parts Identification

2 POSITION TOP BEAM

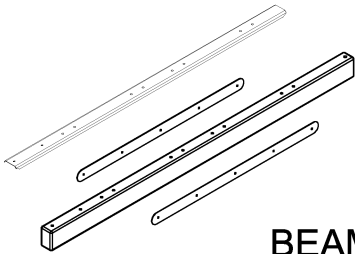

BEAM - 4X6X98"
STRIP - 2 3/4"X75"
TOP PLATE 2 POS

3 POSITION TOP BEAM

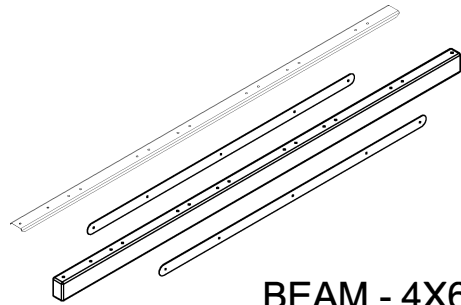

BEAM - 4X6X133"
STRIP - 2 3/4"X110"
TOP PLATE 3 POS

4 POSITION TOP BEAM

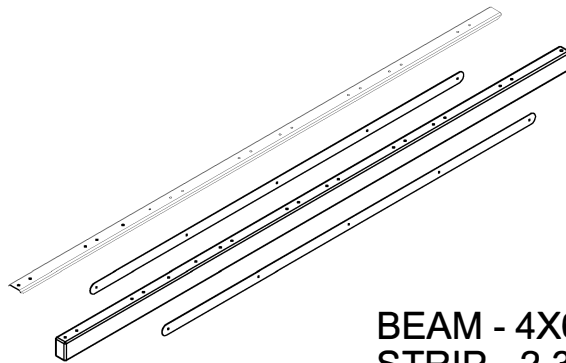

BEAM - 4X6X169"
STRIP - 2 3/4"X132"
TOP PLATE 4 POS



Single Beam

Parts Identification

ID	Description	Part Number	Qty.
A	4x6x120" Single Beam Leg	4L1821-09	2
	4x6x136" Super Single Beam Leg	4L1820-09	
B	4x4x83" Single Beam Leg Support	4L1822-07	1
C	4x6x98" Single Beam Top Beam 2 Pos.	4L930-07	1
	4x6x133" Single Beam Top Beam 3 Pos.	4L916-07	
	4x6x169" Single Beam Top Beam 4 Pos.	4L924-07	
D	Strip - 2 3/4" x 75" (Green)	4M093-07	2
	Strip - 2 3/4" x 110" (Green)	4M050-07	
	Strip - 2 3/4" x 132" (Green)	4M052-07	
E	Top Plate 2 Position	4M1103-09	1
	Top Plate 3 Position	4M1104-09	
	Top Plate 4 Position	4M1105-09	
F	Clamp - Single Beam (Slot Hole)	4M1037-06B	2
G	4x4x25" Double Angle Gussett	4L849	2
AK	4x6x51 1/4" Magellan Cross Brace	4L2154-09	1
M	4x6x57" Mountaineer Cross Brace	4L1489-09	1

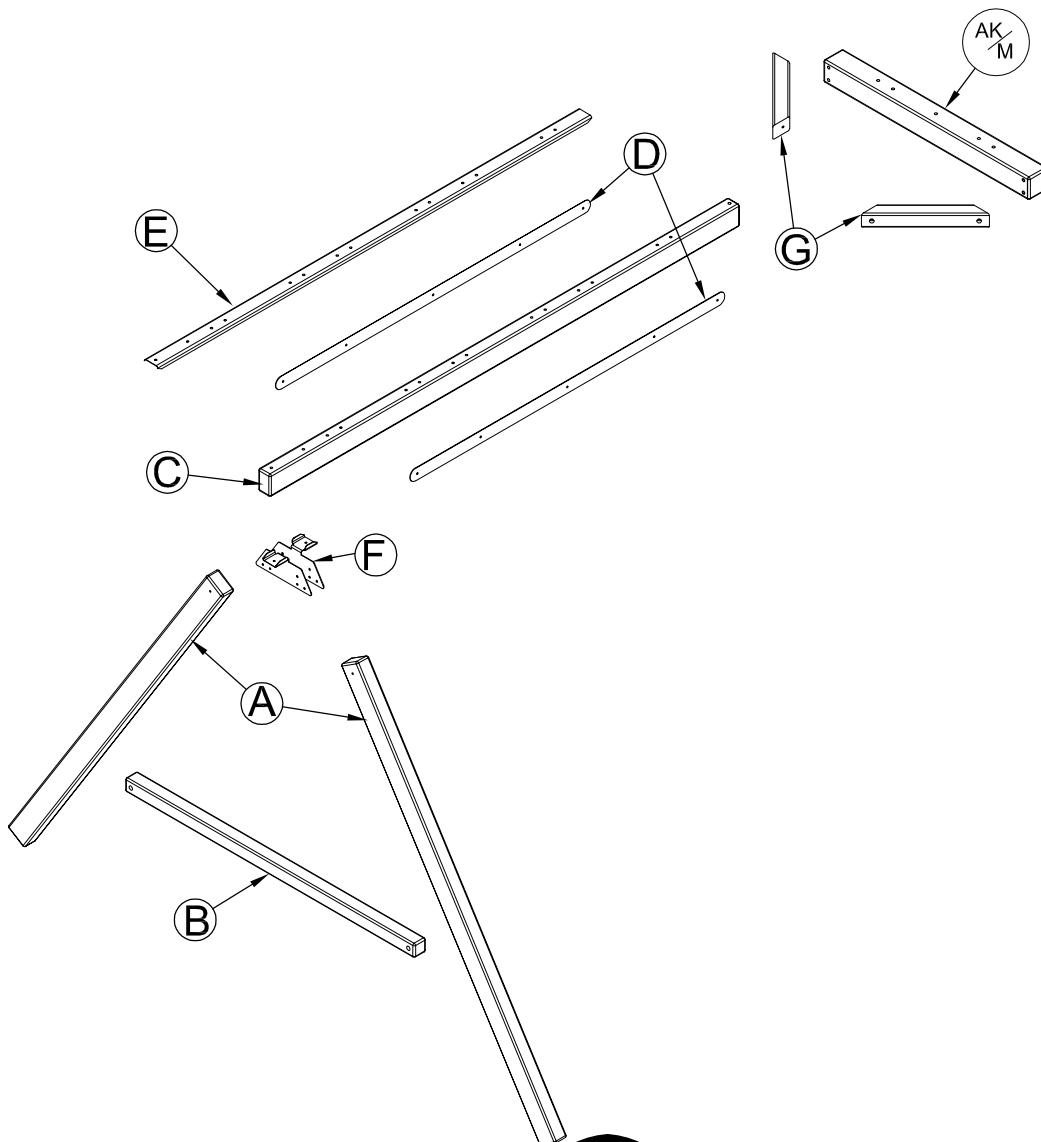



Single Beam Phase 1

Step 1: Gather items A, C, E, F, G & hardware bag.

Step 2: Attach the single beam clamps to angled legs A by inserting (2) 5/16"x4" carriage bolts through the square holes on H and the hole on A as shown below. Use (2) 5/16" flat washers and (2) 5/16" lock nuts as shown in (Fig. 1) to hold clamps in place.

Step 3: Attach top beam C to assembly by placing top plate over holes and inserting (2) 5/16"x6" carriage bolts through the holes of top plate as shown below. Place C over F and align the holes so bolts go through holes in H. Attach with (2) 5/16" flat washers and (2) 5/16" lock nuts (Fig. 2).

****NOTE**** Holes for the 2 and 3 position single beam are at the end of the beam. The 4 position holes for the plate are between the third and fourth position on the beam.

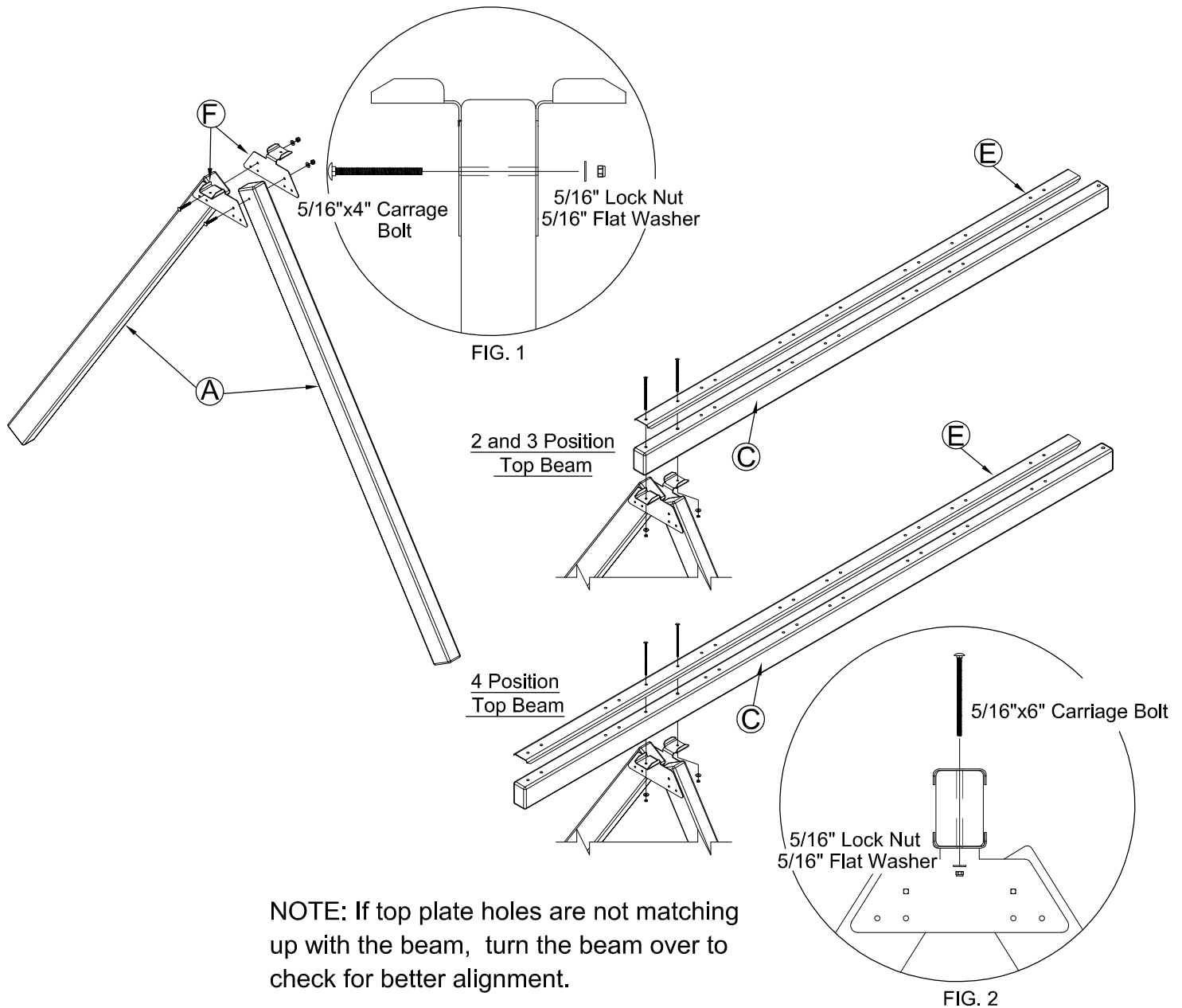

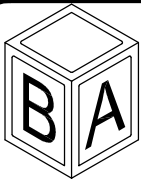

Single Beam Phase 2

Step 1: Gather items J (2), swing hangers, & hardware bag.

Step 2: Attach swing hangers using 6 1/2" carriage bolts as shown below.

Step 3: Center metal strip top to bottom between Top Plate and bottom of 4x6 beam.

Step 4: Start attachment of strip 20 1/2" from end of beam as shown below.

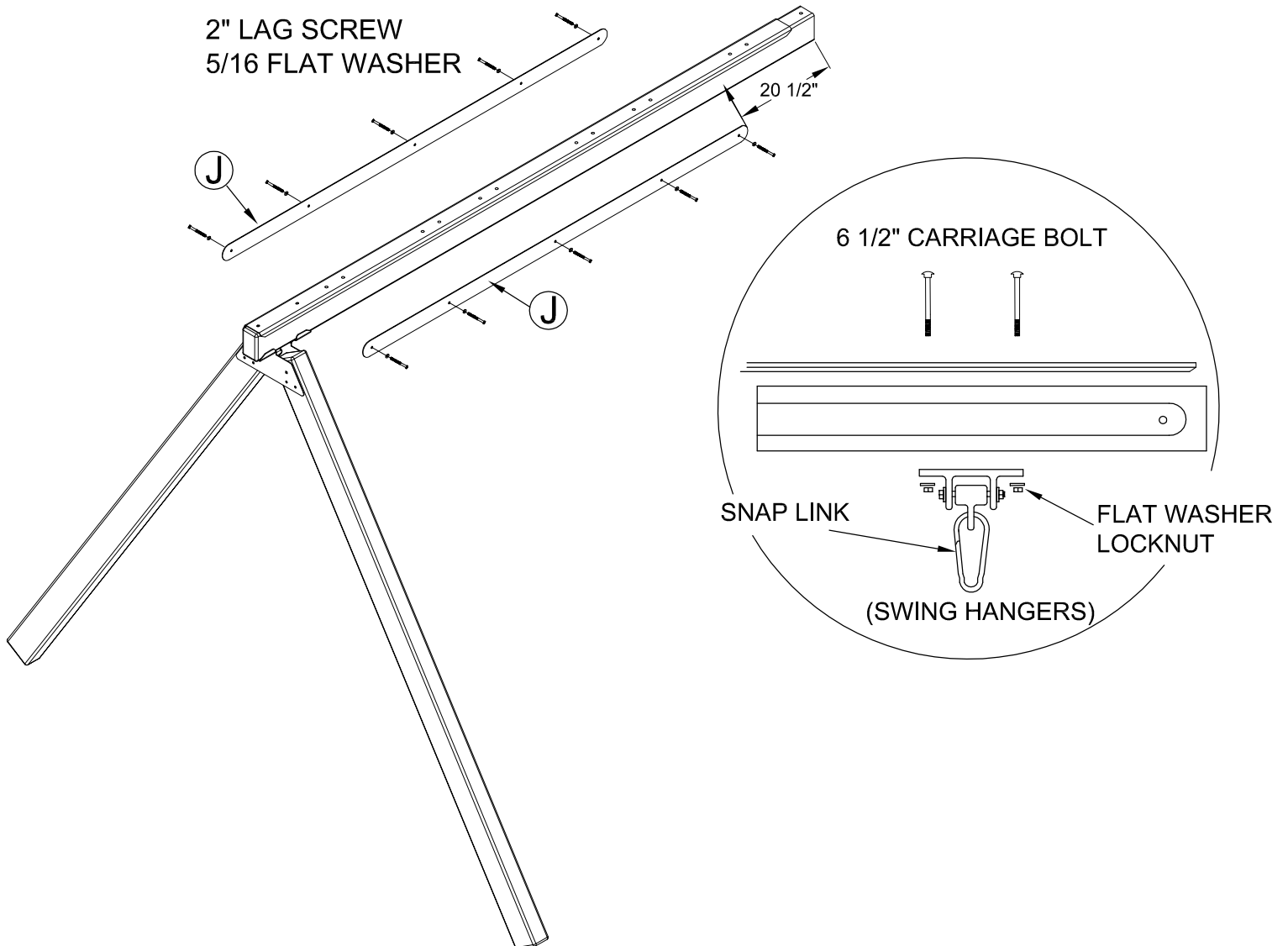

**NOTE: CENTER STRIP PER DETAILS SHOWN ABOVE
AND ATTACH WITH LAGS.**

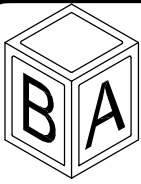

Single Beam Phase 3

Step 1: Gather T clamp & hardware bag.

Step 2: Place T clamp on top and bottom of cross brace over centered pre-drilled hole.

Step 3: Install carriage bolt into center hole of clamp top and bottom as shown.

Attach using acorn nut, split washer and flat washer.

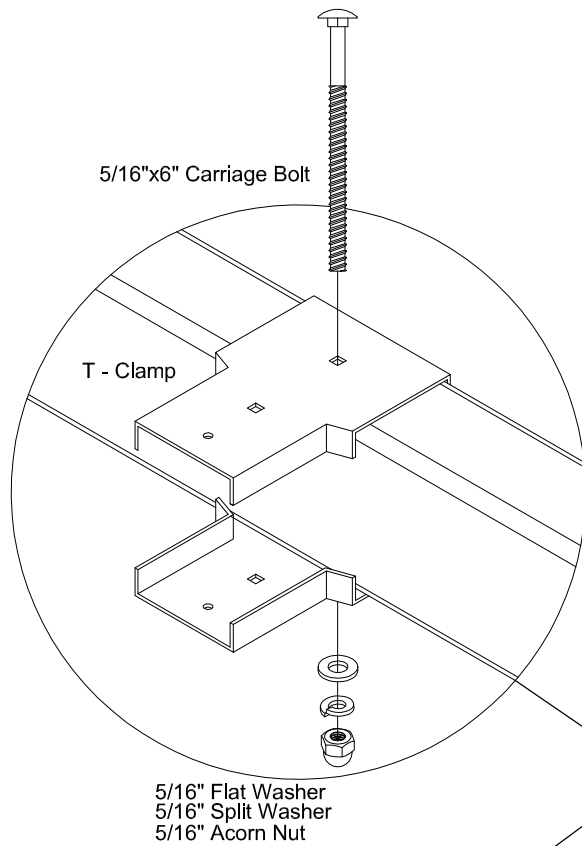

****NOTE**** Do not fully tighten bolts.

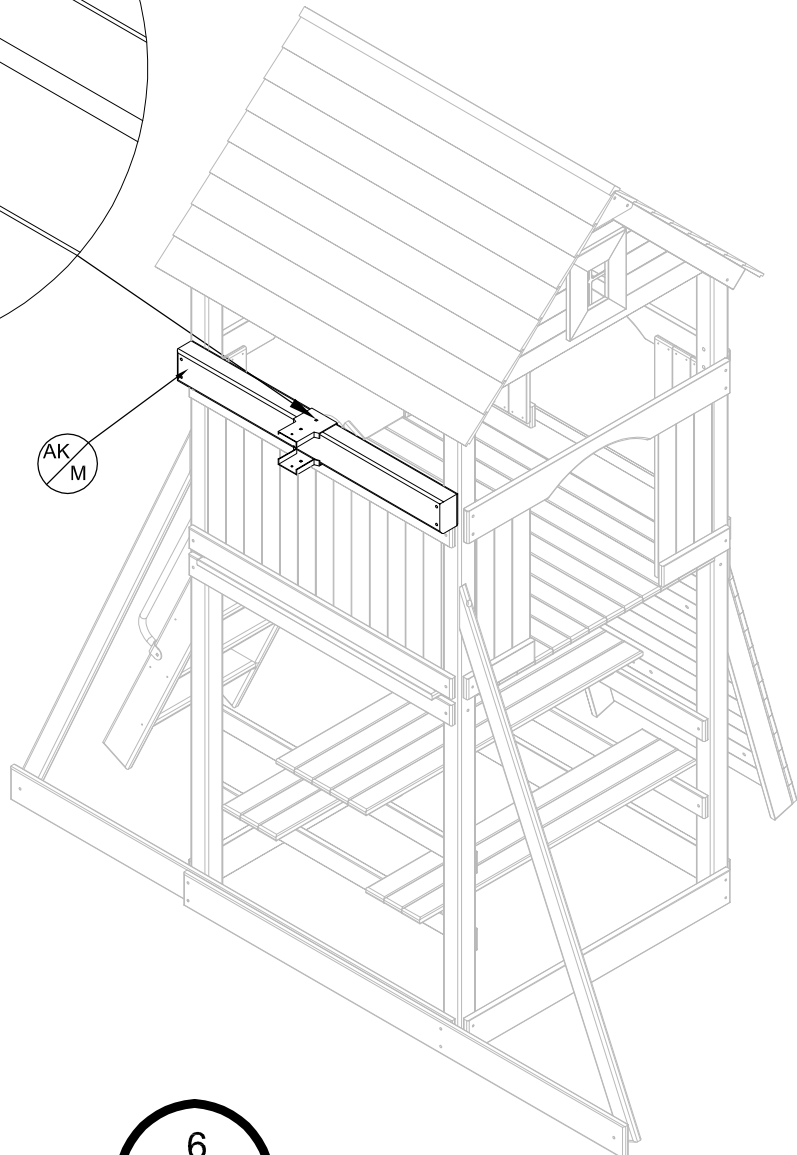



Single Beam Phase 4

Step 1: Gather assembly from phase 3 & hardware bag.

Step 2: Slide top beam into clamp on fort and attach with 5/16"x6" carriage bolts as shown in fig. 1 below.

Step 3: Adjust the single beam legs to make sure the top beam is level. Legs may be taken in or out to adjust on uneven ground.

Step 4: Once top beam is level, secure legs using (8) 5/16"x2 1/2" lag screws per single beam clamp as shown below.

Step 5: Attach support brace B to legs with (2) 4 1/2" lag screws and (2) flat washers.

Step 6: Place double angle gussets G against beam and cross brace & attach with (4) 4 1/2" lag screws and 5/16" washers as shown in Fig G.

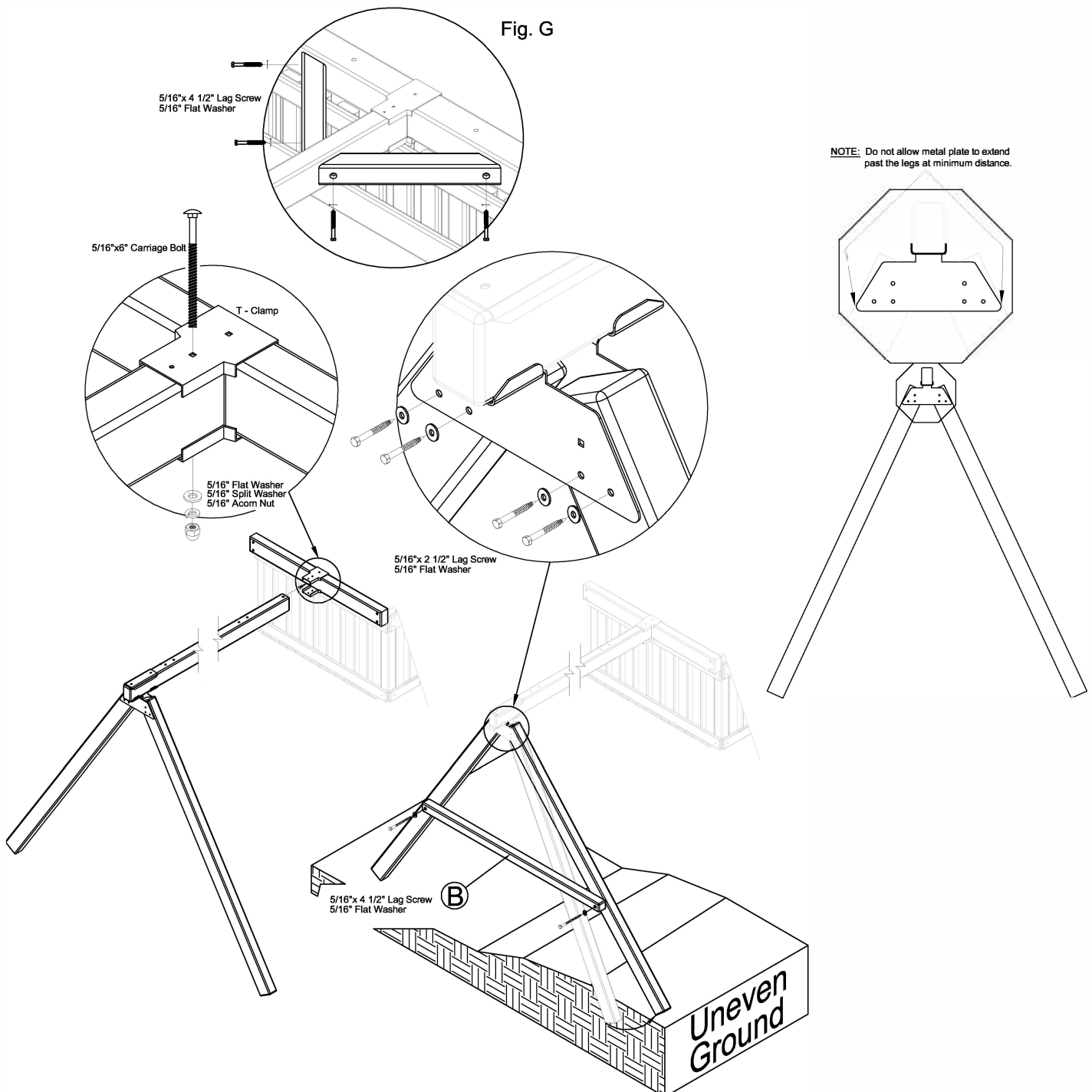



Single Beam Phase 5

REBAR STAKES



Drive stake into ground at an angle.
Attach with lag screws.

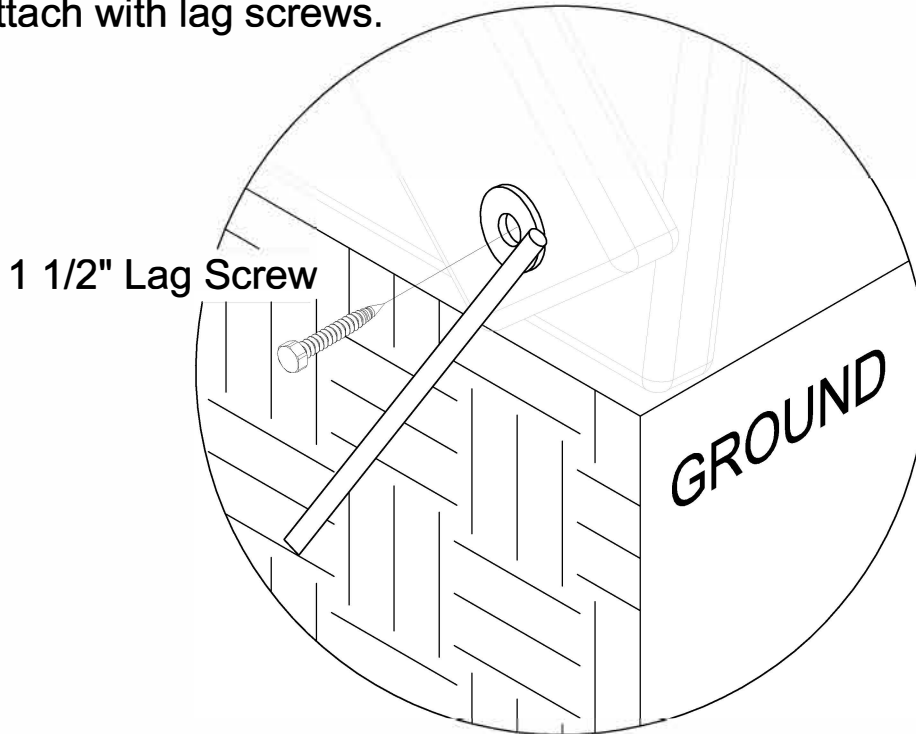

****NOTE**** Attach stakes to 4x6 single beam legs.
Stakes must be located as shown.

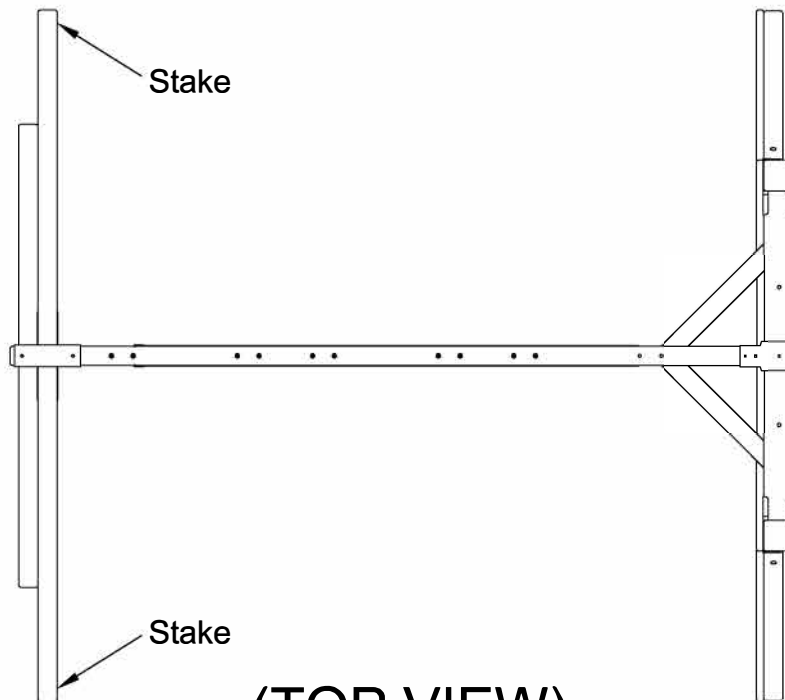

(TOP VIEW)

Failure to use stakes can void warranty and cause injury.